

CAT VC Collet Chucks

- Feature TiN Bearing Nut which considerably improves cutting rigidity and finish
- Extra thick body
- High concentricity and repeatability
- Ideal for high-speed applications

Please note that the maximum RPM listed in our catalog may vary depending on the toolholder shank, weight, balanceability and the G rating.



TIR: 0.00012 or better



Speed: up to 40,000 rpm



Set-up: quick and easy to operate



Coolant-thru: thru tool coolant



Drilling
★★★★☆



Milling
★★★★☆



Reaming
★★★★☆

CAT40

Part Number	Collet Size	Wrench	L	L1	H	D	D1	Back-up Screw
CAT40-VC6-60U	VCK6	GH10	2.362"	0.906"	1.378"-1.772"	1.083"	1.083"	VCG6-8A
CAT40-VC6-90U	VCK6	GH10	3.543"	2.047"	1.378"-1.772"	1.083"	1.244"	VCG6-8A
CAT40-VC6-120U	VCK6	GH10	4.724"	3.228"	1.378"-1.772"	1.083"	1.409"	VCG6-8A
CAT40-VC13-60U	VCK13	GH16	2.362"	1.142"	1.969"-2.362"	1.575"	1.575"	VCG13-15A
CAT40-VC13-90U	VCK13	GH16	3.543"	2.756"	1.969"-2.362"	1.575"	1.083"	VCG13-15A
CAT40-VC13-120U	VCK13	GH16	4.724"	3.937"	1.969"-2.362"	1.575"	1.083"	VCG13-15A

Note:wrench sold separately.

CAT50

Part Number	Collet Size	Wrench	L	L1	H	D	D1	Back-up Screw
CAT50-VC6-105U	VCK6	GH10	4.134"	2.559"	1.378"-1.772"	1.083"	1.315"	VCG6-8A
CAT50-VC6-135U	VCK6	GH10	5.315"	3.740"	1.378"-1.772"	1.083"	1.480"	VCG6-8A
CAT50-VC6-165U	VCK6	GH10	6.496"	4.921"	1.378"-1.772"	1.083"	1.646"	VCG6-8A
CAT50-VC13-105U	VCK13	GH16	4.134"	2.559"	1.969"-2.362"	1.575"	1.772"	VCG13-15A
CAT50-VC13-135U	VCK13	GH16	5.315"	3.740"	1.969"-2.362"	1.575"	1.937"	VCG13-15A
CAT50-VC13-165U	VCK13	GH16	6.496"	4.921"	1.969"-2.362"	1.575"	2.102"	VCG13-15A

Note:wrench sold separately.

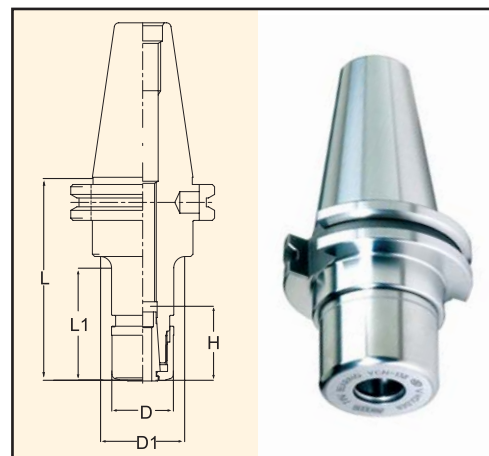

3-Lock VC Collet Chucks for Dual Contact Spindle

3-Lock VC Collet Chucks are available from stock and feature Nikken unique Triple Contact System. Please refer to page 239 in our technical section to learn more about Nikken's revolutionary 3-Lock System and tooling line.

For a complete list of part numbers and pricing, please contact our office at (800) 543-6237



Accessories:



VCK Collets
Page 202



Nut Wrench
Page 204



Back-up screw
Page 204



Coolant-thru nut
Page 204