

HSK ER Collet Chucks

- Ball bearing nut with ground collet race
- AT3 or better taper
- Equipped with a left-hand-threaded stop screw
- Available in high-speed balanceable versions

Please note that the maximum RPM listed in our catalog may vary depending on the toolholder shank, weight, balanceability and the G rating.

- TIR:** < .0001 at collet face
- Speed:** up to 23,000 rpm
- Set-up:** quick and easy
- Coolant-thru:** thru-tool coolant

- Drilling**
★★★★☆
- Milling**
★★★★☆
- Reaming**
★★★★☆
- Tapping**
★★★☆☆

HSK40A/63A

Part Number	Taper	Collet Size	Collet Range	Nut Wrench	L	L1	D
HSK40A-ER11-75	HSK40A	ER11	.019-.275"	011-HEX	2.71"	0.5"	0.71"
HSK40A-ER16-75	HSK40A	ER16	.019-.393"	016-SPAN	2.56"	0.67"	1.26"
HSK40A-ER20-75	HSK40A	ER20	.039-.511"	020-SPAN	2.95"	1.2"	1.38"
HSK40A-ER25-80	HSK40A	ER25	.039-.629"	025-SPAN	3.15"	1.4"	1.65"
HSK40A-ER32-80	HSK40A	ER32	.078-.787"	032-SPAN	3.15"	1.6"	1.97"
HSK63A-ER16-3.00	HSK63A	ER16	.019-.393"	016-SPAN	3.00"	0.866"	1.260"
HSK63A-ER16-5.00	HSK63A	ER16	.019-.393"	016-SPAN	5.00"	0.866"	1.260"
HSK63A-ER20-3.00	HSK63A	ER20	.039-.511"	020-SPAN	3.00"	1.062"	1.378"
HSK63A-ER20-5.00	HSK63A	ER20	.039-.511"	020-SPAN	5.00"	1.062"	1.378"
HSK63A-ER25-3.00	HSK63A	ER25	.039-.629"	025-SPAN	3.00"	1.181"	1.654"
HSK63A-ER25-5.00	HSK63A	ER25	.039-.629"	025-SPAN	5.00"	1.181"	1.654"
HSK63A-ER32-4.00	HSK63A	ER32	.078-.787"	032-SPAN	4.00"	1.260"	1.969"
HSK63A-ER32-6.00	HSK63A	ER32	.078-.787"	032-SPAN	6.00"	1.260"	1.969"
HSK63A-ER40-4.00	HSK63A	ER40	.118-1.023"	040-SPAN	4.00"	1.496"	2.480"
HSK63A-ER40-6.00	HSK63A	ER40	.118-1.023"	040-SPAN	6.00"	1.496"	2.480"

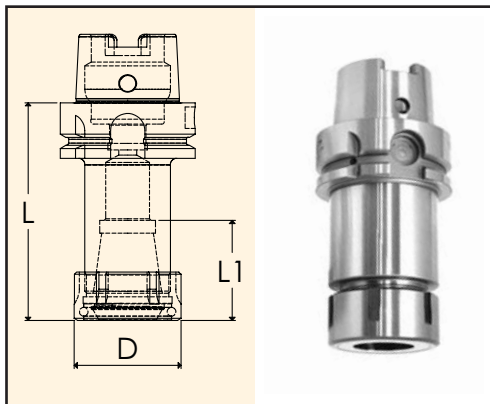

HSK100A

Part Number	Taper	Collet Size	Collet Range	Nut Wrench	L	L1	D
HSK100A-ER16-4.00	HSK100A	ER16	.019-.393"	016-SPAN	4.00"	0.866"	1.260"
HSK100A-ER16-6.00	HSK100A	ER16	.019-.393"	016-SPAN	6.00"	0.866"	1.260"
HSK100A-ER20-4.00	HSK100A	ER20	.039-.511"	020-SPAN	4.00"	1.062"	1.378"
HSK100A-ER20-6.00	HSK100A	ER20	.039-.511"	020-SPAN	6.00"	1.062"	1.378"
HSK100A-ER25-4.00	HSK100A	ER25	.039-.629"	025-SPAN	4.00"	1.181"	1.654"
HSK100A-ER25-6.00	HSK100A	ER25	.039-.629"	025-SPAN	6.00"	1.181"	1.654"
HSK100A-ER32-4.00	HSK100A	ER32	.078-.787"	032-SPAN	4.00"	1.260"	1.969"
HSK100A-ER32-6.00	HSK100A	ER32	.078-.787"	032-SPAN	6.00"	1.260"	1.969"
HSK100A-ER40-4.00	HSK100A	ER40	.118-1.023"	040-SPAN	4.00"	1.496"	2.480"
HSK100A-ER40-6.00	HSK100A	ER40	.118-1.023"	040-SPAN	6.00"	1.496"	2.480"

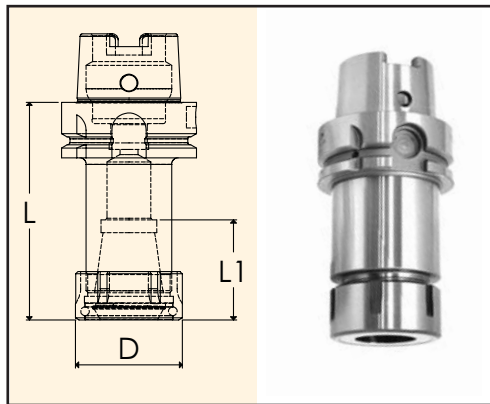

Note: Coolant tube and coolant wrench not included. See page 55 for details.



When removing the back-up screw, ER Collet Chucks have coolant-thru capabilities. No disc, special nut or wrench required!
See ER Coolant Collets on pages 46 - 51.

Accessories:



ER Collets
Pages 46-53



ER Torque Wrench
Page 55



ER Back Up Screw
Page 55



ER Nut
Page 54