

HSK SK Collet Chucks

- Feature TiN Bearing Nut which considerably improves cutting rigidity and finish
- Narrow body allows access to tight spaces and hard to reach areas
- Unique high-pressure coolant collet system for higher accuracy and gripping torque
- 8° taper SK collet provides twice more clamping force and precision than ER Collet Chucks



TIR: 0.0002" at 4xD



Speed: up to 30,000 rpm



Set-up: quick and easy



Coolant-thru: thru-tool coolant



Drilling
★★★★☆



Milling
★★★★☆



Reaming
★★★★☆

Please note that the maximum RPM listed in our catalog may vary depending on the toolholder shank, weight, balanceability and the G rating.

HSK63A

Part Number	Collet Size	Wrench	L	L1	H	D	Back-up Screw
HSK63A-SK6C-100	SK6	SKL-6W	3.937"	2.441"	1.024-1.220"	0.768"	SKG6-6HG
HSK63A-SK6C-120	SK6	SKL-6W	4.724"	2.441"	1.024-1.220"	0.768"	SKG6-6HG
HSK63A-SK6C-150	SK6	SKL-6W	5.906"	2.362"	1.024-1.220"	0.768"	SKG6-6HG
HSK63A-SK10C-105	SK10	SKL-10	4.134"	2.913"	1.378-1.614"	1.083"	SKG10-10HG
HSK63A-SK10C-120	SK10	SKL-10	4.724"	2.362"	1.378-1.614"	1.083"	SKG10-10HG
HSK63A-SK10C-150	SK10	SKL-10	5.906"	2.874"	1.378-1.614"	1.083"	SKG10-10HG
HSK63A-SK16C-120	SK16	9HC16	4.724"	3.583"	1.772-2.047"	1.575"	SKG16-10HG
HSK63A-SK16C-150	SK16	9HC16	5.906"	4.764"	1.772-2.244"	1.575"	SKG16-12HG
HSK63A-SK25C-135	SK25	9HC22	5.315"	4.252"	2.362-2.559"	2.165"	SKG25-18HGE

Note: Wrench and back-up screw not included.
Coolant tube and coolant tube wrench are sold separately. See page 210 for details.

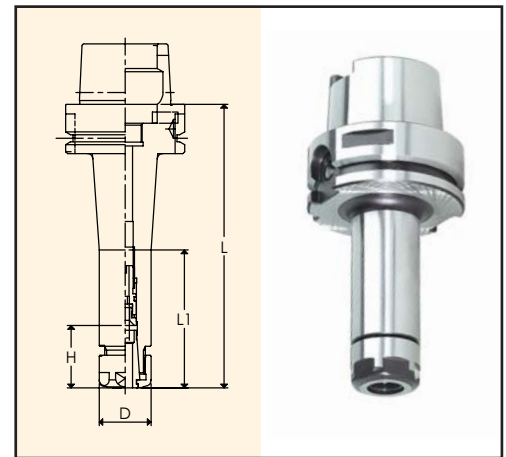

HSK100A

Part Number	Collet Size	Wrench	L	L1	H	D	Back-up Screw
HSK100A-SK6C-105	SK6	SKL-6W	4.134"	2.441"	1.024-1.220"	0.768"	SKG6-6HG
HSK100A-SK10C-105	SK10	SKL-10	4.134"	2.244"	1.378-1.614"	1.083"	SKG10-10HG
HSK100A-SK10C-120	SK10	SKL-10	4.724"	2.913"	1.378-1.614"	1.083"	SKG10-10HG
HSK100A-SK10C-150	SK10	SKL-10	5.906"	3.150"	1.378-1.614"	1.083"	SKG10-10HG
HSK100A-SK10C-200	SK10	SKL-10	7.874"	2.953"	1.378-1.614"	1.083"	SKG10-10HG
HSK100A-SK16C-120	SK16	9HC16	4.724"	3.386"	1.654-2.047"	1.575"	SKG16-10HG
HSK100A-SK16C-150	SK16	9HC16	5.906"	3.543"	1.654-2.244"	1.575"	SKG16-12HG
HSK100A-SK16C-200	SK16	9HC16	7.874"	3.543"	1.654-2.244"	1.575"	SKG16-12HG
HSK100A-SK25C-145	SK25	9HC22	5.709"	4.370"	2.362-2.559"	2.165"	SKG25-18HGE

Note: Wrench and back-up screw not included.
Coolant tube and coolant tube wrench are sold separately. See page 210 for details.

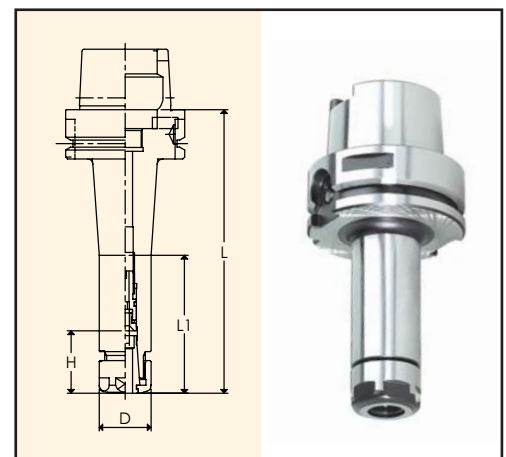

Accessories:



SK Collets
Page 188



Wrench
Page 193



Back-up screw
Page 194



Coolant-thru and Slotted Nuts
Page 192