

HSK VC Collet Chucks

- Feature TiN Bearing Nut which considerably improves cutting rigidity and finish
- Extra thick body
- High concentricity and repeatability
- Ideal for high-speed applications

Please note that the maximum RPM listed in our catalog may vary depending on the toolholder shank, weight, balanceability and the G rating.



TIR: 0.00012 or better



Speed: up to 40,000 rpm



Set-up: quick and easy to operate



Coolant-thru: thru tool coolant



Drilling
★★★★☆



Milling
★★★★☆



Reaming
★★★★☆

HSK40A

Part Number	Collet Size	Wrench	L	L1	H	D	D1	Back-up Screw
HSK40A-VC6-65	VCK6	GH10	2.559"	1.693"	1.38"-1.77"	1.083"	1.362"	VCG6-8A
HSK40A-VC6-90	VCK6	GH10	3.543"	2.677"	1.38"-1.77"	1.083"	1.330"	VCG6-8A
HSK40A-VC13-90	VCK13	GH16	3.543"	2.756"	1.97"-2.36"	1.575"	1.575"	VCG13-15A
HSK40A-VC13-120	VCK13	GH16	4.724"	3.937"	1.97"-2.36"	1.575"	1.575"	VCG13-15A

Note: wrench, coolant tubes and coolant tube wrenches are sold separately. See page 204 for more details.

HSK63A

Part Number	Collet Size	Wrench	L	L1	H	D	D1	Back-up Screw
HSK63A-VC6-70	VCK6	GH10	2.76"	1.614"	1.38"-1.77"	1.083"	1.330"	VCG6-8A
HSK63A-VC6-90	VCK6	GH10	2.54"	2.402"	1.38"-1.77"	1.083"	1.291"	VCG6-8A
HSK63A-VC6-120	VCK6	GH10	4.724"	3.583"	1.38"-1.77"	1.083"	1.457"	VCG6-8A
HSK63A-VC13-90	VCK13	GH16	3.543"	2.520"	1.97"-2.36"	1.575"	1.752"	VCG13-15A
HSK63A-VC13-120	VCK13	GH16	4.724"	3.622"	1.97"-2.36"	1.575"	1.921"	VCG13-15A

Note: wrench, coolant tubes and coolant tube wrenches are sold separately. See page 204 for more details.

HSK100A

Part Number	Collet Size	Wrench	L	L1	H	D	D1	Back-up Screw
HSK100A-VC6-105	VCK6	GH10	4.134"	2.795"	1.38"-1.77"	1.083"	1.346"	VCG6-8A
HSK100A-VC6-135	VCK6	GH10	5.315"	3.976"	1.38"-1.77"	1.083"	1.512"	VCG6-8A
HSK100A-VC6-165	VCK6	GH10	6.496"	5.157"	1.38"-1.77"	1.083"	1.677"	VCG6-8A
HSK100A-VC13-105	VCK13	GH16	4.134"	2.795"	1.97"-2.36"	1.575"	1.807"	VCG13-15A
HSK100A-VC13-135	VCK13	GH16	5.315"	3.976"	1.97"-2.36"	1.575"	1.972"	VCG13-15A
HSK100A-VC13-165	VCK13	GH16	6.496"	5.157"	1.97"-2.36"	1.575"	2.138"	VCG13-15A

Note: wrench, coolant tubes and coolant tube wrenches are sold separately. See page 204 for more details.

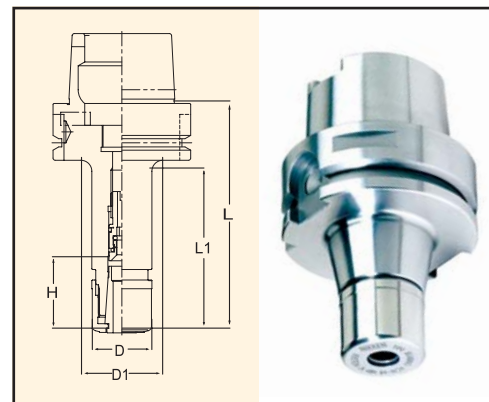

Accessories:



VCK Collets
Page 202



Nut Wrench
Page 204



Back-up screw
Page 204



Coolant-thru nut
Page 204