

HSK End Mill Holders

- End mill inner bore T.I.R. ≤ 0.0002
- Through-spindle coolant capability
- AT3 or better taper



TIR: $< .0002$ run out in ID bore



Milling
★★★★☆



Speed: up to 20,000 rpm



Tapping
★★★★☆



Set-up: quick and easy



Coolant-thru: jet slots (optional)

Please note that the maximum RPM listed in our catalog may vary depending on the toolholder shank, weight, balanceability and the G rating.

HSK63A

Part Number	d	L	L1	D	Set Screw Part Number
HSK63A-0187-3.00	3/16"	3.00"	0.866"	0.748"	S8-32X1/4
HSK63A-0187-5.00	3/16"	5.00"	0.866"	0.748"	S8-32X1/4
HSK63A-0250-3.00	1/4"	3.00"	1.102"	0.787"	S1/4-28X1/4
HSK63A-0250-5.00	1/4"	5.00"	1.102"	0.787"	S1/4-28X1/4
HSK63A-0312-3.00	5/16"	3.00"	1.417"	0.874"	S5/16-24X1/4
HSK63A-0312-5.00	5/16"	5.00"	1.417"	0.874"	S5/16-24X1/4
HSK63A-0375-3.50	3/8"	3.50"	1.574"	1.00"	S3/8-24X5/16
HSK63A-0375-5.00	3/8"	5.00"	1.574"	1.00"	S3/8-24X5/16
HSK63A-0437-4.00	7/16"	4.00"	1.771"	1.378"	S7/16-20X3/8
HSK63A-0437-5.00	7/16"	5.00"	1.771"	1.378"	S7/16-20X3/8
HSK63A-0500-4.00	1/2"	4.00"	1.771"	1.378"	S7/16-20X3/8
HSK63A-0500-5.00	1/2"	5.00"	1.771"	1.378"	S7/16-20X3/8
HSK63A-0625-4.00	5/8"	4.00"	1.889"	1.654"	S9/16-18X1/2
HSK63A-0625-5.00	5/8"	5.00"	1.889"	1.654"	S9/16-18X1/2
HSK63A-0750-4.50	3/4"	4.50"	1.968"	1.889"	S5/8-18X1/2
HSK63A-0750-6.00	3/4"	6.00"	1.968"	1.889"	S5/8-18X1/2
HSK63A-1000-4.50	1"	4.50"	2.755"	2.363"	S3/4-16X11/16 (2)
HSK63A-1000-6.00	1"	6.00"	2.755"	2.363"	S3/4-16X11/16 (2)
HSK63A-1250-4.50	1-1/4"	4.50"	2.952"	2.88"	S3/4-16X11/16 (2)
HSK63A-1250-6.00	1-1/4"	6.00"	2.952"	2.88"	S3/4-16X11/16 (2)

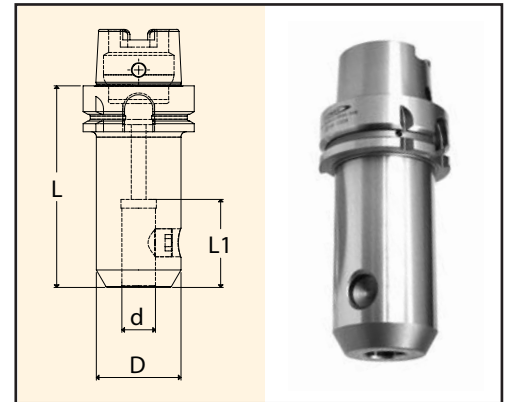

Set Screws are included. Back-up screws not included.
Coolant tube and coolant tube wrench are sold separately.

HSK40A

Part Number	d	L	L1	D	Set Screw Part Number
HSK40A-0125-75	1/8"	2.95"	0.63"	0.75"	S6-32X1/4
HSK40A-0187-75	3/16"	2.95"	0.87"	0.75"	S8-32X1/4
HSK40A-0250-75	1/4"	2.95"	1.42"	0.79"	S1/4-28x1/4
HSK40A-0312-75	5/16"	2.95"	1.42"	0.87"	S5/16-24X1/4
HSK40A-0375-75	3/8"	2.95"	1.57"	1.00"	S3/8-24X5/16
HSK40A-0437-75	7/16"	2.95"	1.78"	1.38"	S7/16-20X3/8
HSK40A-0500-75	1/2"	2.95"	1.78"	1.38"	S7/16-20X3/8
HSK40A-0625-75	5/8"	2.95"	1.89"	1.65"	S9/16-18X1/2
HSK40A-0750-75	3/4"	2.95"	1.97"	1.89"	S5/8-18X1/2

Accessories:



Set Screws
Page 28



Set Screws for Aerospace Holders
Page 28



HSK Coolant Tube
Page 28



HSK Coolant Tube Wrench
Page 28