

HSK and Straight Shank MMC Collet Chucks

- No nut required. Slim, compact nose and front clamping allow greater rigidity and precision gripping
- High concentricity and repeatability
- Easy-to-use draw-in collet clamping pulled by standard side wrench
- Pre-balanced for high-speed applications

Please note that the maximum RPM listed in our catalog may vary depending on the toolholder shank, weight, balanceability and the G rating.



TIR: 0.00012 or better



Speed: up to 30,000 rpm



Set-up: quick and easy to operate



Coolant-thru: thru tool coolant



Drilling
★☆☆☆☆



Milling
★★★★☆



Reaming
★★★★☆

HSK63A/100A

Part Number	Coolant-thru	Collet Series	Wrench	L	L1	D
HSK63A-MMC8C-107-A*	yes	VMK8	Wrench-THEX5	4.153"	1.476"	0.787"
HSK63A-MMC8C-115	yes	VMK8	Wrench-ALLEN6	4.528"	1.299"	0.787"
HSK63A-MMC12C-110-A*	yes	VMK12	Wrench-THEX6	4.331"	1.417"	1.181"
HSK63A-MMC12C-117	yes	VMK12	Wrench-ALLEN6	4.606"	1.417"	1.181"
HSK100A-MMC8C-130	yes	VMK8	Wrench-ALLEN6	5.118"	1.299"	0.787"
HSK100A-MMC12C-130	yes	VMK12	Wrench-ALLEN6	5.118"	1.417"	1.181"

Note: wrench included with holder except for A type holders. Coolant tube and coolant tube wrench are sold separately. *"A"denotes collet is drawn directly from the rear of the holder by a bolt.

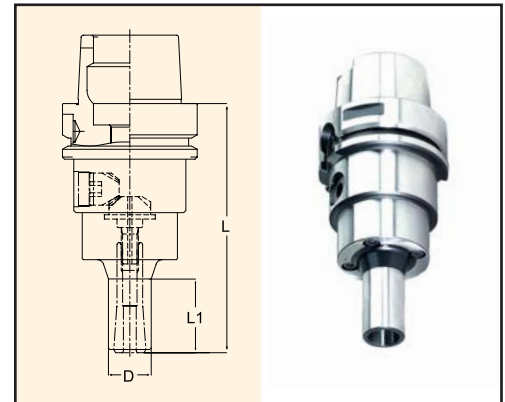

HSK63F

Part Number	Coolant-thru	Collet Series	Wrench	L	L1	D
HSK63F-MMC8C-127	yes	VMK8	Wrench-ALLEN6	5.000"	1.299"	0.787"
HSK63F-MMC12C-129	yes	VMK12	Wrench-ALLEN6	5.078"	1.417"	1.181"

Note: wrench included with holder. Coolant tube and coolant tube wrench are sold separately.

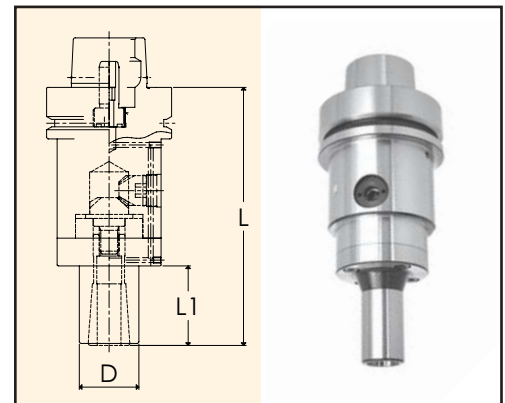

Straight Shank

Part Number	Coolant-thru	Collet Series	Wrench	L	L1	L2	D
K3/4-MMC8C-100	yes	VMK8	Wrench-ALLEN6	3.937"	0.787"	3.149"	0.787"
K1.1/4-MMC8C-122	yes	VMK8	Wrench-ALLEN6	4.803"	1.574"	2.637"	0.787"
K1.1/4-MMC8C-160	yes	VMK8	Wrench-ALLEN6	6.299"	1.574"	2.637"	0.787"

Note: wrench included with holder.



Wrench-THEX5
Wrench-THEX6



Wrench-ALLEN6

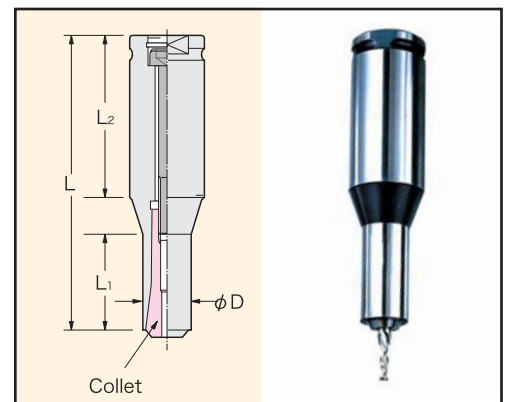

Accessories:



MPK and VMK Collets
Page 210



HSK Coolant Tube
Page 210



HSK Coolant Tube Wrench
Page 210