

NMTB Shell Mill Holders

- Accommodates face mills with bore diameters ranging from 1/2" (12mm) to 2" (50mm)
- Pilot diameter sized for precision fit with cutter
- Removable/replaceable drive keys as standard
- Fine thread locking screw included
- AT3 or better taper

Please note that the maximum RPM listed in our catalog may vary depending on the toolholder shank, weight, balanceability and the G rating.



TIR: < .00015 run out at pilot



Milling
★★★★☆



Speed: up to 30,000 rpm



Set-up: quick and easy



Coolant-thru: thru-pilot (optional)

NMTB30/40/50

Part Number	Taper	d	L	D	L1	Key size	Arbor thread
N3001-0500-1.25	NMTB30	1/2"	1.25"	1.378"	0.57"	1/4"	1/4"-28
N3001-0750-1.31	NMTB30	3/4"	1.31"	1.929"	0.67"	5/16"	3/8"-24
N3001-1000-1.31	NMTB30	1"	1.31"	2.382"	0.67"	3/8"	1/2"-20
N3001-1250-1.44	NMTB30	1-1/4"	1.44"	2.882"	0.67"	1/2"	5/8"-18
N4001-0500-0.87	NMTB40	1/2"	0.87"	1.382"	0.57"	1/4"	1/4"-28
N4001-0750-0.87	NMTB40	3/4"	0.87"	1.937"	0.67"	5/16"	3/8"-24
N4001-1000-1.31	NMTB40	1"	1.31"	2.382"	0.67"	3/8"	1/2"-20
N4001-1250-1.50	NMTB40	1-1/4"	1.50"	2.882"	0.67"	1/2"	5/8"-18
N4001-1500-1.63	NMTB40	1-1/2"	1.63"	3.500"	0.93"	5/8"	3/4"-16
N5001-0750-1.25	NMTB50	3/4"	1.25"	1.929"	0.67"	5/16"	3/8"-24
N5001-1000-1.88	NMTB50	1"	1.88"	2.382"	0.67"	3/8"	1/2"-20
N5001-1250-1.88	NMTB50	1-1/4"	1.88"	2.882"	0.67"	1/2"	5/8"-18
N5001-1500-1.88	NMTB50	1-1/2"	1.88"	3.500"	0.93"	5/8"	3/4"-16
N5001-2000-1.88	NMTB50	2"	1.88"	4.382"	0.93"	3/4"	1"-14

NMTB shanks are suitable for use with Erickson QC spindles.

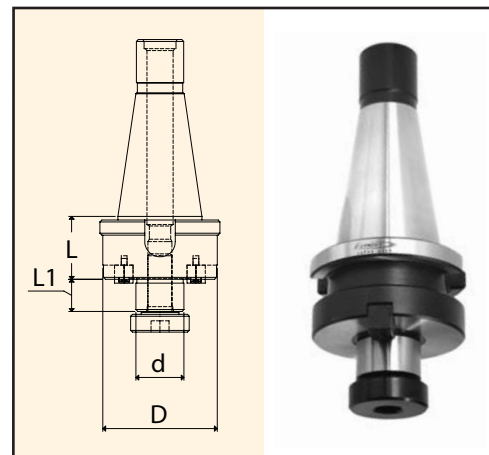

NMTB Face Mill Holders

Part Number	Taper	d	L	D	L1	Key size
N50F1-2000-3.00	NMTB50	2"	3.00"	5.05"	0.87"	3/4"
N50F1-2500-3.00	NMTB50	2-1/2"	3.00"	5.00"	1.18"	1"

NMTB shanks are suitable for use with Erickson QC spindles.
Face Mill Holders are supplied with four 5/8-11 mounting bolts.
Pitch circle diameter is 4".

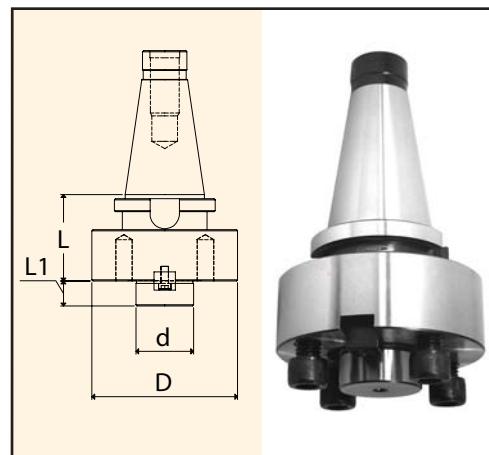

Accessories:



Replacement Keys
Page 83



Replacement Arbor Screws
Page 83

Note: All shell mill holders are coolant-thru. Arbor screws are not coolant-thru but can be modified to facilitate coolant capabilities: see cutter manufacturer for modification requirement.