

NMTB End Mill Holders

NMTB50

Part Number	d	L	L1	D	Set Screw Part Number
N5006-0250-2.75	1/4"	2.75"	1.10"	0.79"	S1/4-28X1/4
N5006-0375-2.75	3/8"	2.75"	1.26"	1.00"	S3/8-24X5/16
N5016-0375-4.50	3/8"	4.50"	1.26"	1.00"	S3/8-24X5/16
N5006-0500-2.75	1/2"	2.75"	1.50"	1.38"	S7/16-20X3/8
N5016-0500-4.50	1/2"	4.50"	1.50"	1.38"	S7/16-20X3/8
N5006-0625-2.75	5/8"	2.75"	1.61"	1.65"	S9/16-18X1/2
N5016-0625-4.50	5/8"	4.50"	1.61"	1.65"	S9/16-18X1/2
N5006-0750-2.88	3/4"	2.88"	1.77"	1.89"	S5/8-18X1/2
N5016-0750-4.50	3/4"	4.50"	1.77"	1.89"	S5/8-18X1/2
N5006-0875-2.88	7/8"	2.88"	2.09"	2.01"	S5/8-18X1/2 (2)
N5016-0875-4.50	7/8"	4.50"	2.09"	2.01"	S5/8-18X1/2 (2)
N5006-1000-3.50	1"	3.50"	2.36"	2.36"	S3/4-16X11/16 (2)
N5016-1000-5.50	1"	5.50"	2.36"	2.36"	S3/4-16X11/16 (2)
N5006-1250-3.50	1-1/4"	3.50"	2.56"	2.48"	S3/4-16X11/16 (2)
N5016-1250-5.50	1-1/4"	5.50"	2.56"	2.48"	S3/4-16X11/16 (2)
N5006-1500-4.00	1-1/2"	4.00"	2.83"	2.99"	S3/4-16X11/16 (2)
N5016-1500-6.00	1-1/2"	6.00"	2.83"	2.99"	S3/4-16X11/16 (2)
N5006-2000-4.69	2"	4.69"	3.34"	3.74"	S1-14X7/8 (2)

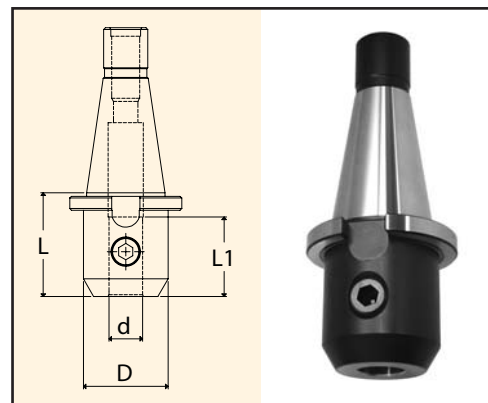

NMTB shanks are suitable for use with Erickson QC spindles.
Set Screws are included. Back-up screws not included.

Accessories:



Set Screws
Page 28



**Set Screws for
Aerospace Holders**
Page 28