



## SK Collet Chuck Features

### LEAN, TOUGH AND EFFICIENT

**Lean:** narrow body design allows access to tight spots

**Versatile:** applicable for all milling, drilling, reaming and rigid tapping applications

**Flexible:** covers sizes from 0.028" to 1"

**Accurate:** two times more accurate than ER Collet Chucks, within 10 times better repeatability

**Extremely Precise:** 0.0002" or less concentricity guarantee with on-size collets

**8° versus 16° collet taper:** double the gripping power over ER Collet Chucks

**Extremely Successful:** over 1 million SK Collet Chucks and 15 million SK collets sold worldwide



### SK Collet Range



**SK6**  
(0.7 - 6.0mm)  
(0.028 - 0.236")

**SK10**  
(1.75 - 10.0mm)  
(0.069 - 0.394")

**SK16**  
(2.75 - 16.0mm)  
(0.108 - 0.630")

**SK20**  
(3.5 - 20.0mm)  
(0.138 - 0.787")

**SK25**  
(16.0 - 25.4mm)  
(0.630 - 1.000")

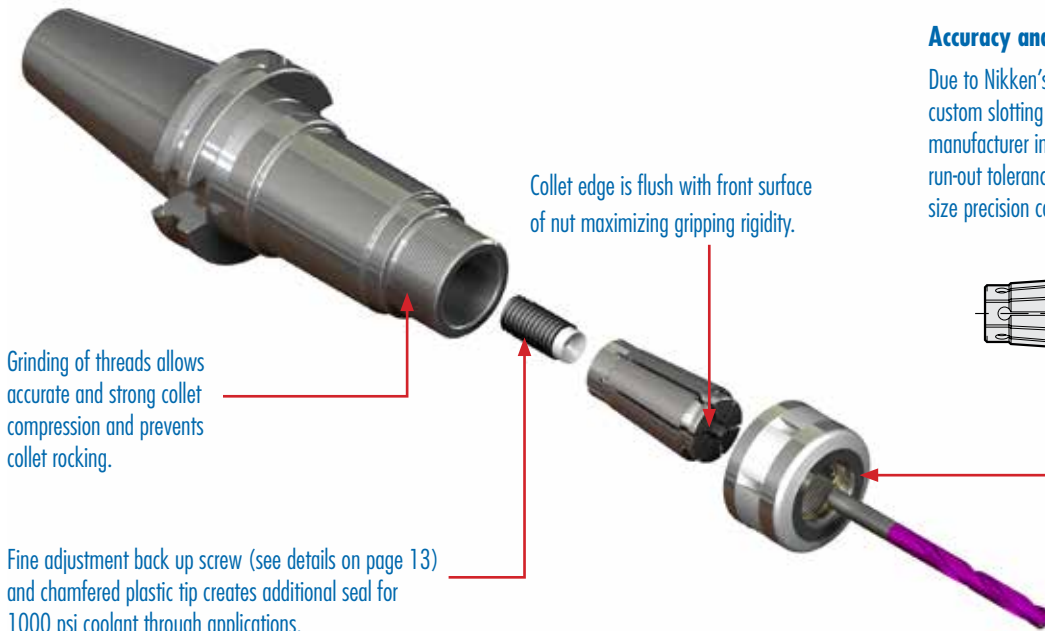

Collet edge is flush with front surface of nut maximizing gripping rigidity.

Grinding of threads allows accurate and strong collet compression and prevents collet rocking.

Fine adjustment back up screw (see details on page 13) and chamfered plastic tip creates additional seal for 1000 psi coolant through applications.

### Accuracy and Flexibility

Due to Nikken's special heat treatment, grinding and custom slotting process, they are the only collet chuck manufacturer in the world that guarantees a 5 micron run-out tolerance for their "on size" fractional and metric size precision collets.

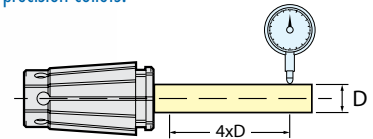

- Extremely hard and smooth surface of the TiN Bearing allows for more thrust load on the collet while preventing additional runout associated with collet twisting.
- Threads are protected to prevent chip packing or stringy birds nests below the collet chuck nut.

## SK Collet Chuck Features

### Increased Gripping Power

The smaller the taper angle is, the better concentricity is obtained.

Our steep 8° collet seats deeper in the body of the holder, providing double the clamping force and precision than traditional 16° ER collets.



### GH Handle

Easy, safe and reliable handling with GH wrench (see page 36).



### Titanium Nitrided Bearing Nut (HV2,200) (US Patent 6923451)

- More efficient than conventional ball bearing built-in nut!
- Good sliding effect due to surface hardness of HV2,200
- No damage, no friction
- No corrosion occurs internally
- Less micro vibration with collet flange contact
- Increase cutting performance and tool life durability
- More cutting rigidity

High pressure 1200 psi fine thread coolant back up screw.

AT3 or better taper - .0028 degree tolerance variation (80 millionths to 126 millionths taper size tolerance).

Ground surface for accurate perpendicular contact between pull stud and taper.

## SK Collet

SK Collets can be used for all applications, from milling to reaming. Standard collets can be used in coolant thru applications (with coolant back-up screws).

### SK Collet vs. ER Collet

- A. Slim design allows for better clearance
- B. Force is parallel to centerline of toolholder
- C. Deeper seating creates greater accuracy
- D. Body and nut are flush for more rigidity

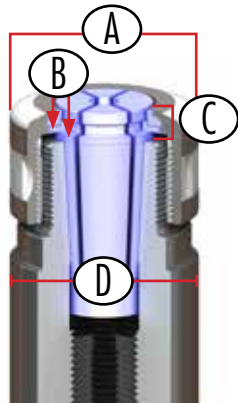

- A. Wide collet = wide nut = less clearance
- B. Force is angular to centerline of toolholder
- C. Shallow seating allows for collet rocking
- D. Body diameter is smaller than nut compromising rigidity

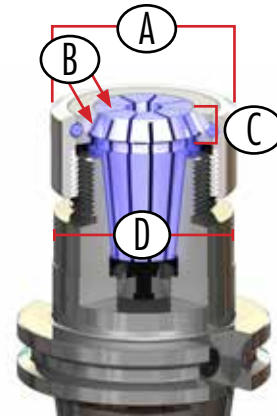

### Lyndex-Nikken Slim Chuck - Flat shoulder pushing

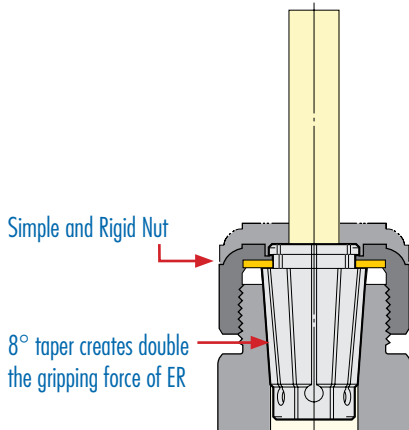

- High Accuracy Due to Flat Shoulder Pushing

### Others - Taper shoulder pushing

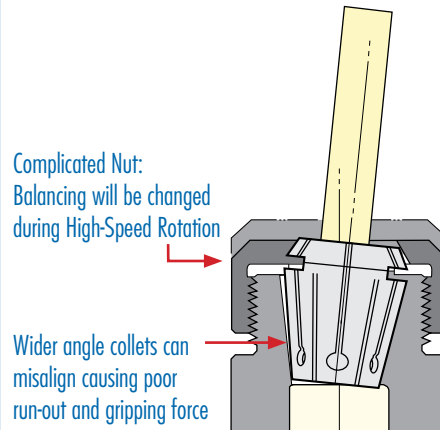

- Unstable Run-out Due to Taper Part Pushing
- Poor Gripping Torque of 12°, 16° taper



## Superior SK Coolant System

Our Slim Chuck features a unique High-Pressure Coolant Collet System which allows for higher accuracy and gripping torque.

### SK Coolant thru options:

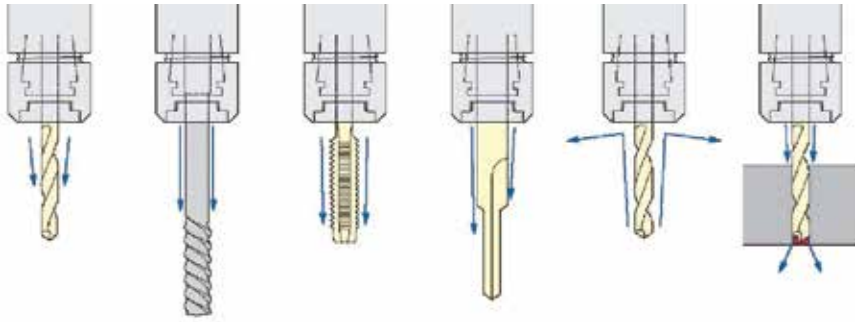

SK Collet Chucks

### Back-up Screw for SK Collet Chuck

#### SKG-12



- Solid steel black oxide coated back up screws
- Accessible and adjustable from both ends

#### SKG-12L



- Excellent for high feed drilling
- Allows cutter repeatability within .0002"

#### SKG16-12HGA



- Ultra High Pressure back up screw capable up to 1200 psi
- Solid steel black oxide coated back-up screws with plastic caps
- 80% thread engagement on fine thread to prevent coolant leakage
- External O-ring provides additional seal to prevent coolant build-up within the toolholder

#### SKG-18H



- Plastic cap is chamfered to accommodate for different sizes
- Excellent for high pressure coolant or oil drilling applications
- Allows cutter repeatability within .0002"



High Pressure Mechanically-Sealed Collets are available

### Applications for SK J Type Nut:

- Tap or specially designed cutting tool
- Burnishing drill for formed hole
- Oil hole drill for through hole drilling
- Cutting tool with coolant grooves
- Mechanical seal prevents dust and swarf entering inside the collet slots

### Slotted Disk:

When the Coolant Nut is paired with the Slotted Disk, coolant is directed to the cutting edge of the cutting tool, making this combination **ideal for non-coolant-thru tools**. The jet coolant pressure creates a tornado effect, ensuring **efficient swarf dispersal**.

### Coolant-Thru Disk:

When the Coolant Nut is paired with the Coolant-Thru Disk, a perfect seal is formed around the cutting tool shank, making this combination ideal for Coolant-Thru tools.

**CAT SK Collet Chucks**

SK Collet Chucks

- Feature TiN Bearing Nut which considerably improves cutting rigidity and finish
- Narrow body allows access to tight spaces and hard to reach areas
- Unique high-pressure coolant collet system for higher accuracy and gripping torque
- 8° taper SK collet provides double the clamping force and precision than ER Collet Chucks



**T.I.R.:** ≤ 0.0002" at 4xD



**Speed:** up to 30,000 rpm



**Set-up:** quick and easy



**Coolant-Thru:** thru-tool coolant



Milling



Tapping



Drilling



Reaming

Please note that the maximum RPM listed in our catalog may vary depending on the toolholder shank, weight, balanceability and the G rating.

**CAT40**

Part Number	Collet Size	Collet Range	Wrench	L	L1	D	Back-Up Screw
CAT40-SK6-90U	SK6	0.028 - 0.236"	SKL-6W	3.543"	1.969"	0.768"	SKG-8
CAT40-SK6-120U	SK6	0.028 - 0.236"	SKL-6W	4.724"	2.441"	0.768"	SKG-8
CAT40-SK6-150U	SK6	0.028 - 0.236"	SKL-6W	5.906"	2.362"	0.768"	SKG-8
CAT40-SK10-90U	SK10	0.069 - 0.394"	SKL-10	3.543"	1.969"	1.083"	SKG-12L
CAT40-SK10-120U	SK10	0.069 - 0.394"	SKL-10	4.724"	2.756"	1.083"	SKG-12L
CAT40-SK10-150U	SK10	0.069 - 0.394"	SKL-10	5.906"	2.874"	1.083"	SKG-12L
CAT40-SK10-180U	SK10	0.069 - 0.394"	SKL-10	7.086"	2.874"	1.083"	SKG-12L
CAT40-SK16-90U	SK16	0.108 - 0.630"	9HC16	3.543"	1.969"	1.575"	SKG-18L
CAT40-SK16-120U	SK16	0.108 - 0.630"	9HC16	4.724"	3.150"	1.575"	SKG-18L
CAT40-SK16-150U	SK16	0.108 - 0.630"	9HC16	5.906"	4.331"	1.575"	SKG-18L
CAT40-SK16-180U	SK16	0.108 - 0.630"	9HC16	7.086"	5.710"	1.575"	SKG-18L
CAT40-SK20-65U-IDU*	SK20	0.138 - 0.787"	9HC22	2.559"	1.809"	1.909"	SKG-22
CAT40-SK20-90U	SK20	0.138 - 0.787"	9HC22	3.543"	2.793"	1.909"	SKG-22
CAT40-SK20-120U	SK20	0.138 - 0.787"	9HC22	4.724"	3.974"	1.909"	SKG-22
CAT40-SK20-150U-IDU*	SK20	0.138 - 0.787"	9HC22	5.906"	5.156"	1.909"	SKG-22
CAT40-SK20-180U-IDU*	SK20	0.138 - 0.787"	9HC22	7.086"	6.337"	1.909"	SKG-22
CAT40-SK25-90U	SK25	0.630 - 1.000"	9HC22	3.543"	2.165"	2.165"	SKG-28
CAT40-SK25-120U	SK25	0.630 - 1.000"	9HC22	4.724"	3.346"	2.165"	SKG-28

Note: \*-IDU\* type holders have a pre-machined counter-bore on the drive key to accept Balluff BIS-C122-04/L RFID chips (10 X 4.5mm size)

**CAT50**

Part Number	Collet Size	Collet Range	Wrench	L	L1	D	Back-Up Screw
CAT50-SK6-105U	SK6	0.028 - 0.236"	SKL-6W	4.134"	2.362"	0.768"	SKG-8
CAT50-SK6-165U	SK6	0.028 - 0.236"	SKL-6W	6.496"	2.441"	0.768"	SKG-8
CAT50-SK6-195U	SK6	0.028 - 0.236"	SKL-6W	7.677"	2.362"	0.768"	SKG-8
CAT50-SK10-105U	SK10	0.069 - 0.394"	SKL-10	4.134"	2.362"	1.083"	SKG-12L
CAT50-SK10-165U	SK10	0.069 - 0.394"	SKL-10	6.496"	2.953"	1.083"	SKG-12L
CAT50-SK10-195U	SK10	0.069 - 0.394"	SKL-10	7.677"	2.953"	1.083"	SKG-12L
CAT50-SK10-225U	SK10	0.069 - 0.394"	SKL-10	8.858"	2.953"	1.083"	SKG-12L
CAT50-SK16-105U	SK16	0.108 - 0.630"	9HC16	4.134"	2.559"	1.575"	SKG-18L
CAT50-SK16-165U	SK16	0.108 - 0.630"	9HC16	6.496"	3.543"	1.575"	SKG-18L
CAT50-SK16-195U	SK16	0.108 - 0.630"	9HC16	7.677"	3.543"	1.575"	SKG-18L
CAT50-SK20-105U-IDU*	SK20	0.138 - 0.787"	9HC22	4.134"	3.384"	1.909"	SKG-22
CAT50-SK20-165U	SK20	0.138 - 0.787"	9HC22	6.496"	5.746"	1.909"	SKG20-18HG
CAT50-SK20-195U-IDU*	SK20	0.138 - 0.787"	9HC22	7.677"	6.299"	1.909"	SKG-22
CAT50-SK25-105U	SK25	0.630 - 1.000"	9HC22	4.134"	2.559"	2.165"	SKG-28
CAT50-SK25-165U	SK25	0.630 - 1.000"	9HC22	6.496"	4.921"	2.165"	SKG-28
CAT50-SK25-195U	SK25	0.630 - 1.000"	9HC22	7.677"	6.102"	2.165"	SKG-28

Note: Wrench and back-up screw not included.

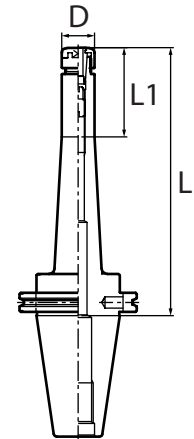

Available in **TAPER PLUS**

Dual-taper and flange contact available. See pages 22-23.

**TAPER PLUS  
COMBINING TAPER ACCURACY  
WITH FLANGE RIGIDITY!**

- Outstanding Runout Accuracy for longer tool life
- Vibration Dampening for increased productivity
- High Rigidity for smooth and stable cutting



## CAT SK Collet Chucks

### CAT40 - DIN

Part Number	Collet Size	Collet Range	Wrench	L	L1	D	Back-Up Screw
CAT40-SK6F-90U	SK6	0.028 - 0.236"	SKL-6W	3.543"	1.969"	0.768"	SKG6-6HG
CAT40-SK6F-120U	SK6	0.028 - 0.236"	SKL-6W	4.724"	2.441"	0.768"	SKG6-6HG
CAT40-SK6F-150U	SK6	0.028 - 0.236"	SKL-6W	5.906"	2.362"	0.768"	SKG6-6HG
CAT40-SK10F-90U	SK10	0.069 - 0.394"	SKL-10	3.543"	1.969"	1.083"	SKG10-10HG
CAT40-SK10F-120U	SK10	0.069 - 0.394"	SKL-10	4.724"	2.756"	1.083"	SKG10-10HG
CAT40-SK10F-150U	SK10	0.069 - 0.394"	SKL-10	5.906"	2.874"	1.083"	SKG10-10HG
CAT40-SK16F-60U	SK16	0.108 - 0.630"	9HC16	2.362"	1.181"	1.575"	N/A
CAT40-SK16F-90U	SK16	0.108 - 0.630"	9HC16	3.543"	1.969"	1.575"	SKG16-12HG
CAT40-SK16F-120U	SK16	0.108 - 0.630"	9HC16	4.724"	3.150"	1.575"	SKG16-12HG
CAT40-SK16F-150U	SK16	0.108 - 0.630"	9HC16	5.906"	4.331"	1.575"	SKG16-12HG
CAT40-SK25F-90U	SK25	0.630 - 1.000"	9HC22	3.543"	2.165"	2.165"	SKG25-18HGE
CAT40-SK25F-120U	SK25	0.630 - 1.000"	9HC22	4.724"	3.346"	2.165"	SKG25-18HGE

Note: CAT40 - DIN - Wrench and back-up screw not included.

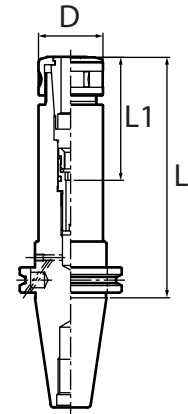

SK Collet Chucks

### CAT40 - High-Speed

Part Number	Collet Size	Collet Range	Wrench	L	L1	D	Back-Up Screw
CAT40-SK6-90UP	SK6	0.028 - 0.236"	GH6	3.543"	2.165"	0.768"	SKG-8
CAT40-SK6-120UP	SK6	0.028 - 0.236"	GH6	4.724"	2.637"	0.768"	SKG-8
CAT40-SK6-150UP	SK6	0.028 - 0.236"	GH6	5.906"	4.528"	0.768"	SKG-8
CAT40-SK10-90UP	SK10	0.069 - 0.394"	GH10	3.543"	2.165"	1.083"	SKG-12L
CAT40-SK10-120UP	SK10	0.069 - 0.394"	GH10	4.724"	3.346"	1.083"	SKG-12L
CAT40-SK10-150UP	SK10	0.069 - 0.394"	GH10	5.906"	4.528"	1.083"	SKG-12L
CAT40-SK16-60UP	SK16	0.108 - 0.630"	GH16	2.362"	1.181"	1.575"	N/A
CAT40-SK16-90UP	SK16	0.108 - 0.630"	GH16	3.543"	2.165"	1.575"	SKG-18L
CAT40-SK16-120UP	SK16	0.108 - 0.630"	GH16	4.724"	3.346"	1.575"	SKG-18L
CAT40-SK16-150UP	SK16	0.108 - 0.630"	GH16	5.906"	4.528"	1.575"	SKG-18L
CAT40-SK20-65UP-IDU*	SK20	0.138 - 0.787"	GH20	2.559"	1.809"	1.909"	SKG-22
CAT40-SK20-90UP-IDU*	SK20	0.138 - 0.787"	GH20	3.543"	2.793"	1.909"	SKG-22
CAT40-SK20-120UP-IDU*	SK20	0.138 - 0.787"	GH20	4.724"	3.974"	1.909"	SKG-22
CAT40-SK25-90UP	SK25	0.630 - 1.000"	GH25	3.543"	2.165"	2.165"	SKG-28
CAT40-SK25-120UP	SK25	0.630 - 1.000"	GH25	4.724"	3.346"	2.165"	SKG-28

Note:

- DIN type high-speed toolholders available. Please contact us for more information.
- \*-IDU" type holders have a pre-machined counter-bore on the drive key to accept Balluff BIS-C122-04/L RFID chips (10 X 4.5mm size)

### CAT50 - High-Speed

Part Number	Collet Size	Collet Range	Wrench	L	L1	D	Back-Up Screw
CAT50-SK6-105UP	SK6	0.028 - 0.236"	GH6	4.134"	2.756"	0.768"	SKG-8
CAT50-SK6-165UP	SK6	0.028 - 0.236"	GH6	6.496"	5.118"	0.768"	SKG-8
CAT50-SK10-105UP	SK10	0.069 - 0.394"	GH10	4.134"	2.756"	1.083"	SKG-12L
CAT50-SK10-165UP	SK10	0.069 - 0.394"	GH10	6.496"	5.118"	1.083"	SKG-12L
CAT50-SK10-195UP	SK10	0.069 - 0.394"	GH10	7.677"	6.299"	1.083"	SKG-12L
CAT50-SK16-105UP	SK16	0.108 - 0.630"	GH16	4.134"	2.756"	1.575"	SKG-18L
CAT50-SK16-165UP	SK16	0.108 - 0.630"	GH16	6.496"	5.118"	1.575"	SKG-18L
CAT50-SK16-195UP	SK16	0.108 - 0.630"	GH16	7.677"	6.299"	1.575"	SKG-18L
CAT50-SK25-105UP	SK25	0.630 - 1.000"	GH25	4.134"	2.756"	2.165"	SKG-28
CAT50-SK25-165UP	SK25	0.630 - 1.000"	GH25	6.496"	5.118"	2.165"	SKG-28
CAT50-SK25-195UP	SK25	0.630 - 1.000"	GH25	7.677"	6.299"	2.165"	SKG-28

Note: CAT50 - High-Speed - Wrench and back-up screw not included.

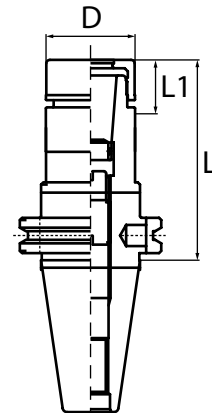



## BT SK Collet Chucks

- Feature TiN Bearing Nut which considerably improves cutting rigidity and finish
- Narrow body allows access to tight spaces and hard to reach areas
- Unique high-pressure coolant collet system for higher accuracy and gripping torque
- 8° taper SK collet provides double the clamping force and precision than ER Collet Chucks



**T.I.R.:** ≤ 0.0002" at 4xD



**Speed:** up to 30,000 rpm



**Set-up:** quick and easy



**Coolant-Thru:** thru-tool coolant



Milling



Tapping



Drilling



Reaming

Please note that the maximum RPM listed in our catalog may vary depending on the toolholder shank, weight, balanceability and the G rating.

### BT30

Part Number	Collet Size	Collet Range	Wrench	L	L1	D	Back-Up Screw
BT30-SK6-60	SK6	0.028 - 0.236"	SKL-6W	2.362"	1.299"	0.768"	SKG-8
BT30-SK6-90	SK6	0.028 - 0.236"	SKL-6W	3.543"	2.205"	0.768"	SKG-8
BT30-SK10-45	SK10	0.069 - 0.394"	SKL-10	1.772"	0.866"	1.083"	SKG-12S
BT30-SK10-60	SK10	0.069 - 0.394"	SKL-10	2.362"	1.378"	1.083"	SKG-12L
BT30-SK10-90	SK10	0.069 - 0.394"	SKL-10	3.543"	2.559"	1.083"	SKG-12L
BT30-SK16-60	SK16	0.108 - 0.630"	9HC16	2.362"	1.457"	1.575"	SKG-12L
BT30-SK16-90	SK16	0.108 - 0.630"	9HC16	3.543"	2.638"	1.575"	SKG-12
BT30-SK20-60	SK20	0.138 - 0.787"	9HC22	2.362"	1.496"	1.909"	SKG-12S
BT30-SK20-90	SK20	0.138 - 0.787"	9HC22	3.543"	2.677"	1.909"	SKG-12
BT30-SK25-90	SK25	0.630 - 1.000"	9HC22	3.543"	2.559"	2.165"	SKG-12

Available in **TAPER PLUS** Dual-taper and flange contact

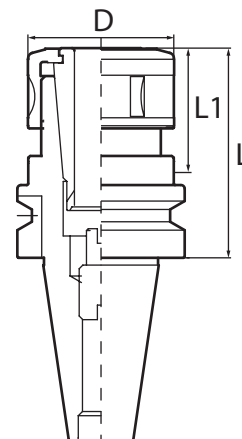

### BT40

Part Number	Collet Size	Collet Range	Wrench	L	L1	D	Back-Up Screw
BT40-SK6-90	SK6	0.028 - 0.236"	SKL-6W	3.543"	2.008"	0.768"	SKG-8
BT40-SK6-120	SK6	0.028 - 0.236"	SKL-6W	4.724"	2.362"	0.768"	SKG-8
BT40-SK6-150	SK6	0.028 - 0.236"	SKL-6W	5.906"	2.362"	0.768"	SKG-8
BT40-SK10-90	SK10	0.069 - 0.394"	SKL-10	3.543"	1.890"	1.083"	SKG-12L
BT40-SK10-120	SK10	0.069 - 0.394"	SKL-10	4.724"	2.874"	1.083"	SKG-12L
BT40-SK10-150	SK10	0.069 - 0.394"	SKL-10	5.906"	2.874"	1.083"	SKG-12L
BT40-SK10-180	SK10	0.069 - 0.394"	SKL-10	7.086"	-	1.083"	SKG-12L
BT40-SK16-90	SK16	0.108 - 0.630"	9HC16	3.543"	2.283"	1.575"	SKG-18L
BT40-SK16-120	SK16	0.108 - 0.630"	9HC16	4.724"	3.465"	1.575"	SKG-18L
BT40-SK16-150	SK16	0.108 - 0.630"	9HC16	5.906"	4.646"	1.575"	SKG-18L
BT40-SK16-180	SK16	0.108 - 0.630"	9HC16	7.086"	6.023"	1.575"	SKG-18L
BT40-SK25-75	SK25	0.630 - 1.000"	9HC22	2.953"	1.850"	2.165"	SKG-12
BT40-SK25-90	SK25	0.630 - 1.000"	9HC22	3.543"	2.402"	2.165"	SKG-28
BT40-SK25-120	SK25	0.630 - 1.000"	9HC22	4.724"	3.583"	2.165"	SKG-28

Note: Wrench and back-up screw not included.

Available in **TAPER PLUS** Dual-taper and flange contact

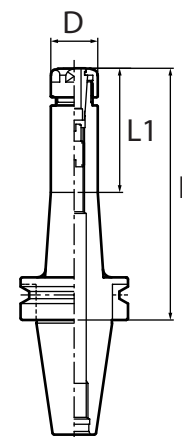



## BT SK Collet Chucks

### BT50

Part Number	Collet Size	Collet Range	Wrench	L	L1	D	Back-Up Screw
BT50-SK6-105	SK6	0.028 - 0.236"	SKL-6W	4.134"	2.165"	0.768"	SKG-8
BT50-SK6-165	SK6	0.028 - 0.236"	SKL-6W	6.496"	2.362"	0.768"	SKG-8
BT50-SK6-195	SK6	0.028 - 0.236"	SKL-6W	7.677"	2.362"	0.768"	SKG-8
BT50-SK10-105	SK10	0.069 - 0.394"	SKL-10	4.134"	2.244"	1.083"	SKG-12L
BT50-SK10-165	SK10	0.069 - 0.394"	SKL-10	6.496"	2.953"	1.083"	SKG-12L
BT50-SK10-195	SK10	0.069 - 0.394"	SKL-10	7.677"	2.953"	1.083"	SKG-12L
BT50-SK16-105	SK16	0.108 - 0.630"	9HC16	4.134"	2.441"	1.575"	SKG-18L
BT50-SK16-165	SK16	0.108 - 0.630"	9HC16	6.496"	3.543"	1.575"	SKG-18L
BT50-SK16-195	SK16	0.108 - 0.630"	9HC16	7.677"	3.543"	1.575"	SKG-18L
BT50-SK25-105	SK25	0.630 - 1.000"	9HC22	4.134"	2.441"	2.165"	SKG-28
BT50-SK25-165	SK25	0.630 - 1.000"	9HC22	6.496"	4.803"	2.165"	SKG-28
BT50-SK25-195	SK25	0.630 - 1.000"	9HC22	7.677"	5.984"	2.165"	SKG-28

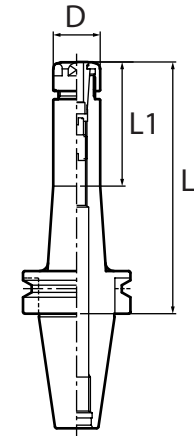

**BT SK Collet Chucks - High-Speed**

SK Collet Chucks

**BT30 - High-Speed**

Part Number	Collet Size	Collet Range	Wrench	L	L1	D	Back-Up Screw
BT30-SK6-60P	SK6	0.028 - 0.236"	GH6	2.362"	1.496"	0.768"	SKG-8
BT30-SK6-90P	SK6	0.028 - 0.236"	GH6	3.543"	2.480"	0.768"	SKG-8
BT30-SK10-45P	SK10	0.069 - 0.394"	GH10	1.772"	0.906"	1.083"	SKG-12S
BT30-SK10-60P	SK10	0.069 - 0.394"	GH10	2.362"	2.677"	1.083"	SKG-12L
BT30-SK10-90P	SK10	0.069 - 0.394"	GH10	3.543"	1.496"	1.083"	SKG-12L
BT30-SK16-60P	SK16	0.108 - 0.630"	GH16	2.362"	1.496"	1.575"	SKG-12L
BT30-SK16-90P	SK16	0.108 - 0.630"	GH16	3.543"	2.677"	1.575"	SKG-12
BT30-SK20-60P	SK20	0.138 - 0.787"	GH20	2.362"	1.496"	1.909"	SKG-12S
BT30-SK20-90P	SK20	0.138 - 0.787"	GH20	3.543"	2.677"	1.909"	SKG-12
BT30-SK25-90P	SK25	0.630 - 1.000"	GH25	3.543"	1.693"	2.165"	SKG-28

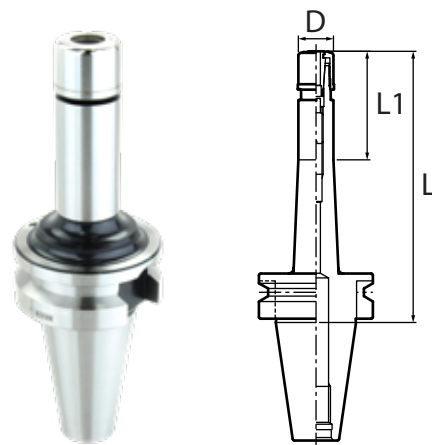

**BT40 - High-Speed**

Part Number	Collet Size	Collet Range	Wrench	L	L1	D	Back-Up Screw
BT40-SK6-90P	SK6	0.028 - 0.236"	GH6	3.543"	2.086"	0.768"	SKG-8
BT40-SK6-120P	SK6	0.028 - 0.236"	GH6	4.724"	3.661"	0.768"	SKG-8
BT40-SK6-150P	SK6	0.028 - 0.236"	GH6	5.906"	4.843"	0.768"	SKG-8
BT40-SK10-90P	SK10	0.069 - 0.394"	GH10	3.543"	2.480"	1.083"	SKG-12L
BT40-SK10-120P	SK10	0.069 - 0.394"	GH10	4.724"	3.661"	1.083"	SKG-12L
BT40-SK10-150P	SK10	0.069 - 0.394"	GH10	5.906"	2.874"	1.083"	SKG-12L
BT40-SK16-90P	SK16	0.108 - 0.630"	GH16	3.543"	2.480"	1.575"	SKG-18L
BT40-SK16-120P	SK16	0.108 - 0.630"	GH16	4.724"	3.661"	1.575"	SKG-18L
BT40-SK16-150P	SK16	0.108 - 0.630"	GH16	5.906"	4.646"	1.575"	SKG-18L
BT40-SK25-75P	SK25	0.630 - 1.000"	GH25	2.953"	1.890"	2.165"	SKG-12
BT40-SK25-90P	SK25	0.630 - 1.000"	GH25	3.543"	2.480"	2.165"	SKG-28
BT40-SK25-120P	SK25	0.630 - 1.000"	GH25	4.724"	3.661"	2.165"	SKG-28

**BT50 - High-Speed**

Part Number	Collet Size	Collet Range	Wrench	L	L1	D	Back-Up Screw
BT50-SK6-105P	SK6	0.028 - 0.236"	GH6	4.134"	2.638"	0.768"	SKG-8
BT50-SK6-165P	SK6	0.028 - 0.236"	GH6	6.496"	5.000"	0.768"	SKG-8
BT50-SK6-195P	SK6	0.028 - 0.236"	GH6	7.677"	2.362"	0.768"	SKG-8
BT50-SK10-105P	SK10	0.069 - 0.394"	GH10	4.134"	2.638"	1.083"	SKG-12L
BT50-SK10-165P	SK10	0.069 - 0.394"	GH10	6.496"	5.000"	1.083"	SKG-12L
BT50-SK10-195P	SK10	0.069 - 0.394"	GH10	7.677"	6.181"	1.083"	SKG-12L
BT50-SK16-105P	SK16	0.108 - 0.630"	GH16	4.134"	2.638"	1.575"	SKG-18L
BT50-SK16-165P	SK16	0.108 - 0.630"	GH16	6.496"	5.000"	1.575"	SKG-18L
BT50-SK16-195P	SK16	0.108 - 0.630"	GH16	7.677"	3.543"	1.575"	SKG-18L
BT50-SK25-105P	SK25	0.630 - 1.000"	GH25	4.134"	2.638"	2.165"	SKG-28
BT50-SK25-165P	SK25	0.630 - 1.000"	GH25	6.496"	5.000"	2.165"	SKG-28
BT50-SK25-195P	SK25	0.630 - 1.000"	GH25	7.677"	5.984"	2.165"	SKG-28

Note: Wrench and back-up screw not included.

Available in **TAPER PLUS**   
 Dual-taper and flange contact available.  
 See pages 24-25.

**TAPER PLUS  
COMBINING TAPER ACCURACY  
WITH FLANGE RIGIDITY!**

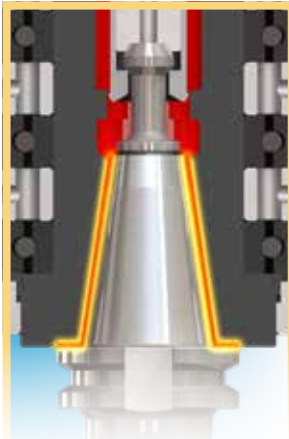

- Outstanding Runout Accuracy for longer tool life
- Vibration Dampening for increased productivity
- High Rigidity for smooth and stable cutting



## Straight Shank SK Collet Chucks



**T.I.R.:** ≤ 0.0002" at 4xD



**Speed:** up to 30,000 rpm



**Set-up:** quick and easy



**Coolant-Thru:** thru-tool coolant



Milling



Tapping



Drilling



Reaming

- Feature TiN Bearing Nut which considerably improves cutting rigidity and finish
- Narrow body allows access to tight spaces and hard to reach areas
- Unique high-pressure coolant collet system for higher accuracy and gripping torque
- 8° taper SK collet provides double the clamping force and precision than ER Collet Chucks

Please note that the maximum RPM listed in our catalog may vary depending on the toolholder shank, weight, balanceability and the G rating.

### Straight Shank

Part Number	Collet Size	Collet Range	Wrench	L	D
K3/4-SK10-100	SK10	0.069 - 0.394"	SKL-10	3.937"	1.083"
K3/4-SK10-120	SK10	0.069 - 0.394"	SKL-10	4.724"	1.083"
K1.1/4-SK6-120	SK6	0.028 - 0.236"	SKL-6W	4.724"	0.768"
K1.1/4-SK6-170	SK6	0.028 - 0.236"	SKL-6W	6.693"	0.768"
K1.1/4-SK10-120	SK10	0.069 - 0.394"	SKL-10	4.724"	1.083"
K1.1/4-SK10-150	SK10	0.069 - 0.394"	SKL-10	5.906"	1.083"
K1.1/4-SK10-210	SK10	0.069 - 0.394"	SKL-10	8.268"	1.083"
K1.1/4-SK16-120	SK16	0.108 - 0.630"	9HC16	4.724"	1.575"
K1.1/4-SK16-150	SK16	0.108 - 0.630"	9HC16	5.906"	1.575"
K1.1/4-SK16-210	SK16	0.108 - 0.630"	9HC16	8.268"	1.575"
K1.1/4-SK25-150	SK25	0.630 - 1.000"	9HC22	5.906"	2.165"

Note: Wrench and back-up screw not included.

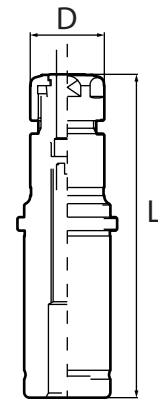

SK Collets  
Page 30



Wrench  
Page 36



Back-up  
Screw  
Page 37



Coolant-thru  
Nut  
Page 35

## HSK SK Collet Chucks

- Feature TiN Bearing Nut which considerably improves cutting rigidity and finish
- Narrow body allows access to tight spaces and hard to reach areas
- Unique high-pressure coolant collet system for higher accuracy and gripping torque
- 8° taper SK collet provides double the clamping force and precision than ER Collet Chucks



**T.I.R.:** ≤ 0.0002" at 4xD



**Speed:** up to 30,000 rpm



**Set-up:** quick and easy



**Coolant-Thru:** thru-tool coolant



Milling



Tapping



Drilling



Reaming

Please note that the maximum RPM listed in our catalog may vary depending on the toolholder shank, weight, balanceability and the G rating.

### HSK63A

Part Number	Collet Size	Collet Range	Wrench	L	L1	D	Back-Up Screw
HSK63A-SK6C-100	SK6	0.028 - 0.236"	SKL-6W	3.937"	2.441"	0.768"	SKG6-6HG
HSK63A-SK6C-120	SK6	0.028 - 0.236"	SKL-6W	4.724"	2.441"	0.768"	SKG6-6HG
HSK63A-SK6C-150	SK6	0.028 - 0.236"	SKL-6W	5.906"	2.362"	0.768"	SKG6-6HG
HSK63A-SK10C-105	SK10	0.069 - 0.394"	SKL-10	4.134"	2.913"	1.083"	SKG10-10HG
HSK63A-SK10C-120	SK10	0.069 - 0.394"	SKL-10	4.724"	2.362"	1.083"	SKG10-10HG
HSK63A-SK10C-150	SK10	0.069 - 0.394"	SKL-10	5.906"	2.874"	1.083"	SKG10-10HG
HSK63A-SK16C-120	SK16	0.108 - 0.630"	9HC16	4.724"	3.583"	1.575"	SKG16-10HG
HSK63A-SK16C-150	SK16	0.108 - 0.630"	9HC16	5.906"	4.764"	1.575"	SKG16-12HG
HSK63A-SK25C-135	SK25	0.630 - 1.000"	9HC22	5.315"	4.252"	2.165"	SKG25-18HGE

Note: Wrench and back-up screw not included. Coolant tube and coolant tube wrench are sold separately.

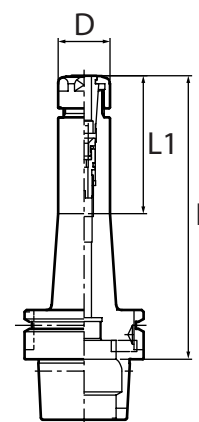

### HSK100A

Part Number	Collet Size	Collet Range	Wrench	L	L1	D	Back-Up Screw
HSK100A-SK6C-105	SK6	0.028 - 0.236"	SKL-6W	4.134"	2.441"	0.768"	SKG6-6HG
HSK100A-SK10C-105	SK10	0.069 - 0.394"	SKL-10	4.134"	2.244"	1.083"	SKG10-10HG
HSK100A-SK10C-120	SK10	0.069 - 0.394"	SKL-10	4.724"	2.913"	1.083"	SKG10-10HG
HSK100A-SK10C-150	SK10	0.069 - 0.394"	SKL-10	5.906"	3.150"	1.083"	SKG10-10HG
HSK100A-SK10C-200	SK10	0.069 - 0.394"	SKL-10	7.874"	2.953"	1.083"	SKG10-10HG
HSK100A-SK16C-120	SK16	0.108 - 0.630"	9HC16	4.724"	3.386"	1.575"	SKG16-10HG
HSK100A-SK16C-150	SK16	0.108 - 0.630"	9HC16	5.906"	3.543"	1.575"	SKG16-12HG
HSK100A-SK16C-200	SK16	0.108 - 0.630"	9HC16	7.874"	3.543"	1.575"	SKG16-12HG
HSK100A-SK25C-145	SK25	0.630 - 1.000"	9HC22	5.709"	4.370"	2.165"	SKG25-18HGE

Note: Wrench and back-up screw not included. Coolant tube and coolant tube wrench are sold separately.

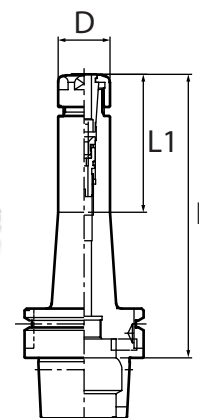

### Coolant Tube Wrench for HSK Holders

Part Number	Description
HSK40-WRENCH	Wrench for HSK40 Coolant Tube
HSK63-WRENCH	Wrench for HSK63 Coolant Tube
HSK100-WRENCH	Wrench for HSK100 Coolant Tube



### Coolant Tube for HSK Holders

Part Number	Description
HSK40-TUBE	Coolant Tube for HSK40 holder
HSK63-TUBE	Coolant Tube for HSK63 holder
HSK100-TUBE	Coolant Tube for HSK100 holder



Note: Coolant Tube Wrenches are needed to remove or install coolant tubes in HSK toolholders.





## HSK SK Collet Chucks - High-Speed

### HSK32E and HSK40E High-Speed

Part Number	Collet Size	Collet Range	Wrench	L	L1	D	Back-Up Screw
HSK32E-SK6-50P	SK6	0.028 - 0.236"	GH6	1.969"	1.260"	0.768"	-
HSK32E-SK10-60P	SK10	0.069 - 0.394"	GH10	2.362"	1.732"	1.083"	SKG-6L
HSK40E-SK6-60P	SK6	0.028 - 0.236"	GH6	2.362"	1.456"	0.768"	-
HSK40E-SK10-60P	SK10	0.069 - 0.394"	GH10	2.362"	2.047"	1.083"	SKG-6L
HSK40E-SK16-80P	SK16	0.108 - 0.630"	GH16	3.149"	-	1.575"	SKG-12L

Note: Wrench and back-up screw not included.

Coolant tube and coolant tube wrench are sold separately. See page 20 for details.

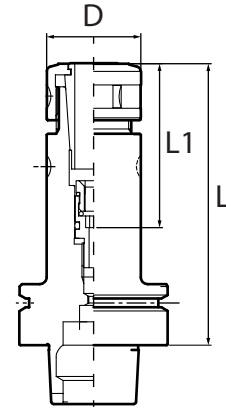

### HSK63A High-Speed

Part Number	Collet Size	Collet Range	Wrench	L	L1	D	Back-Up Screw
HSK63A-SK6C-100P	SK6	0.028 - 0.236"	GH6	3.937"	2.913"	0.768"	SKG6-6HG
HSK63A-SK6C-120P	SK6	0.028 - 0.236"	GH6	4.724"	3.700"	0.768"	SKG6-6HG
HSK63A-SK6C-150P	SK6	0.028 - 0.236"	GH6	5.906"	4.882"	0.768"	SKG6-6HG
HSK63A-SK10C-105P	SK10	0.069 - 0.394"	GH10	4.134"	3.110"	1.083"	SKG10-10HG
HSK63A-SK10C-120P	SK10	0.069 - 0.394"	GH10	4.724"	3.700"	1.083"	SKG10-10HG
HSK63A-SK10C-150P	SK10	0.069 - 0.394"	GH10	5.906"	4.882"	1.083"	SKG10-10HG
HSK63A-SK16C-120P	SK16	0.108 - 0.630"	GH16	4.724"	3.700"	1.575"	SKG16-10HG
HSK63A-SK16C-150P	SK16	0.108 - 0.630"	GH16	5.906"	4.882"	1.575"	SKG16-12HG
HSK63A-SK25C-135P	SK25	0.630 - 1.000"	GH25	5.315"	4.252"	2.165"	SKG25-18HGE

Note: Wrench and back-up screw not included.

Coolant tube and coolant tube wrench are sold separately. See page 20 for details.

### HSK63F High-Speed

Part Number	Collet Size	Collet Range	Wrench	L	L1	D	Back-Up Screw
HSK63F-SK10C-105P	SK10	0.069 - 0.394"	GH10	4.134"	2.913"	1.083"	SKG10-10HG
HSK63F-SK16C-120P	SK16	0.108 - 0.630"	GH16	4.724"	3.583"	1.575"	SKG16-10HG

Note: Wrench and back-up screw not included.

Coolant tube and coolant tube wrench are sold separately. See page 20 for details.

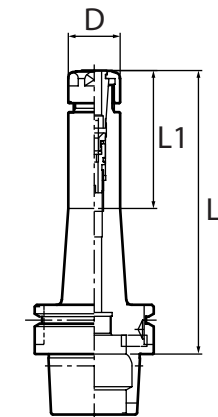

### HSK100A High-Speed

Part Number	Collet Size	Collet Range	Wrench	L	L1	D	Back-Up Screw
HSK100A-SK6C-105P	SK6	0.028 - 0.236"	GH6	4.134"	2.637"	0.768"	SKG6-6HG
HSK100A-SK10C-105P	SK10	0.069 - 0.394"	GH10	4.134"	2.441"	1.083"	SKG10-10HG
HSK100A-SK10C-120P	SK10	0.069 - 0.394"	GH10	4.724"	3.031"	1.083"	SKG10-10HG
HSK100A-SK10C-150P	SK10	0.069 - 0.394"	GH10	5.906"	4.213"	1.083"	SKG10-10HG
HSK100A-SK10C-200P	SK10	0.069 - 0.394"	GH10	7.874"	6.732"	1.083"	SKG10-10HG
HSK100A-SK16C-120P	SK16	0.108 - 0.630"	GH16	4.724"	3.583"	1.575"	SKG16-10HG
HSK100A-SK16C-150P	SK16	0.108 - 0.630"	GH16	5.906"	3.740"	1.575"	SKG16-12HG
HSK100A-SK16C-200P	SK16	0.108 - 0.630"	GH16	7.874"	6.732"	1.575"	SKG16-12HG
HSK100A-SK25C-145P	SK25	0.630 - 1.000"	GH25	5.709"	4.567"	2.165"	SKG25-18HGE

Note: Wrench and back-up screw not included.

Coolant tube and coolant tube wrench are sold separately. See page 20 for details.

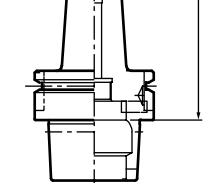

SK Collets  
Page 30



Wrench  
Page 36



Back-up  
Screw  
Page 37



Coolant-thru  
Nut  
Page 35

# Taper Plus CAT SK Collet Chucks

SK Collet Chucks

## Taper Plus Advantages

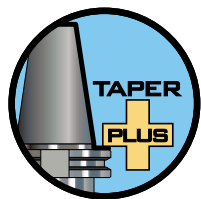

- Outstanding runout accuracy for longer tool life
- Vibration dampening for increased productivity
- High rigidity for smooth and stable cutting
- Interchangeable between standard and dual face contact spindles
- 53% more surface area contact than just the taper alone

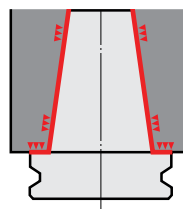

## Taper Plus - CAT40 SK6

Part Number	Collet Series	Collet Range	Wrench	L	ℓ	ℓ1	C	C1	Back Up Screw	Figure
NCAT40-SK6C-90U	SK6	0.028 - 0.236"	SKL-6W	3.543"	2.165"	2.793"	0.768"	1.750"	SKG6-6HG	2
NCAT40-SK6C-120U	SK6	0.028 - 0.236"	SKL-6W	4.724"	2.441"	3.346"	0.768"	1.260"	SKG6-6HG	2
NCAT40-SK6C-150U	SK6	0.028 - 0.236"	SKL-6W	4.724"	2.441"	3.346"	0.768"	1.260"	SKG6-6HG	2

## Taper Plus - CAT40 SK10

Part Number	Collet Series	Collet Range	Wrench	L	ℓ	ℓ1	C	C1	Back Up Screw 4mm+ (.157"+)	Back Up Screw 6mm+ (.236"+)	Figure
NCAT40-SK10C-90U	SK10	0.069 - 0.394"	SKL-10	3.543"	1.969"	2.793"	1.083"	1.750"	SKG10-10HGA	SKG10-10HG	2
NCAT40-SK10C-120U	SK10	0.069 - 0.394"	SKL-10	4.724"	2.756"	3.346"	1.083"	1.260"	SKG10-10HGA	SKG10-10HG	2
NCAT40-SK10C-150U	SK10	0.069 - 0.394"	SKL-10	5.906"	2.874"	4.528"	1.083"	1.343"	SKG10-10HGA	SKG10-10HG	3
NCAT40-SK10C-180U	SK10	0.069 - 0.394"	SKL-10	7.087"	2.874"	5.827"	1.083"	1.343"	SKG10-10HGA	SKG10-10HG	3

## Taper Plus - CAT40 SK16

Part Number	Collet Series	Collet Range	Wrench	L	ℓ	ℓ1	C	C1	Back Up Screw 5mm+ (.197"+)	Back Up Screw 10mm+ (.394"+)	Figure
NCAT40-SK16C-60U	SK16	0.108 - 0.630"	9HC16	2.362"	1.612"	n/a	1.575"	1.575"	SKG16-10HGA	SKG16-10HG	1
NCAT40-SK16C-90U	SK16	0.108 - 0.630"	9HC16	3.543"	2.165"	2.793"	1.575"	1.750"	SKG16-12HGA	SKG16-12HG	2
NCAT40-SK16C-120U	SK16	0.108 - 0.630"	9HC16	4.724"	3.547"	4.175"	1.575"	1.750"	SKG16-12HGA	SKG16-12HG	2
NCAT40-SK16C-150U	SK16	0.108 - 0.630"	9HC16	5.906"	4.728"	5.356"	1.575"	1.750"	SKG16-12HGA	SKG16-12HG	2
NCAT40-SK16C-180U	SK16	0.108 - 0.630"	9HC16	7.087"	5.081"	5.709"	1.575"	1.750"	SKG16-12HGA	SKG16-12HG	2

## Taper Plus - CAT40 SK20

Part Number	Collet Series	Collet Range	Wrench	L	ℓ	ℓ1	C	C1	Back Up Screw	Figure
NCAT40-SK20C-50U-IDU*	SK20	0.138 - 0.787"	9HC22	1.969"	n/a	1.219"	1.909"	n/a	SKG20-12HG	2
NCAT40-SK20C-65U-IDU*	SK20	0.138 - 0.787"	9HC22	2.559"	n/a	1.809"	1.909"	n/a	SKG20-12HG	2
NCAT40-SK20C-90U-IDU*	SK20	0.138 - 0.787"	9HC22	3.543"	n/a	2.793"	1.909"	n/a	SKG20-18HG	2
NCAT40-SK20C-120U-IDU*	SK20	0.138 - 0.787"	9HC22	4.724"	n/a	3.974"	1.909"	n/a	SKG20-18HG	2
NCAT40-SK20C-150U-IDU*	SK20	0.138 - 0.787"	9HC22	5.906"	n/a	5.516"	1.909"	n/a	SKG20-18HG	2
NCAT40-SK20C-180U-IDU*	SK20	0.138 - 0.787"	9HC22	7.087"	n/a	6.337"	1.909"	n/a	SKG20-18HG	2

Note: \*-IDU" type holders have a pre-machined counter-bore on the drive key to accept Balluff BIS-C122-04/L RFID chips (10 X 4.5mm size)

## Taper Plus - CAT40 SK25

Part Number	Collet Series	Collet Range	Wrench	L	ℓ	ℓ1	C	C1	Back Up Screw	Figure
NCAT40-SK25C-90U	SK25	0.630 - 1.000"	9HC22	3.543"	2.793"	n/a	2.165"	2.165"	SKG25-18HGD	1
NCAT40-SK25C-120U	SK25	0.630 - 1.000"	9HC22	4.724"	3.974"	n/a	2.165"	2.165"	SKG25-24HG	1



Fig. 1

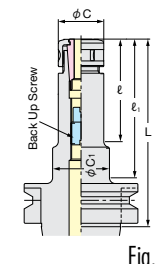

Fig. 2

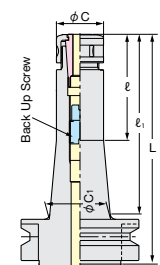
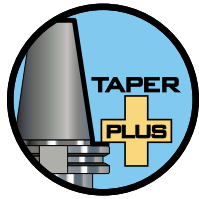

Fig. 3



## Taper Plus CAT SK Collet Chucks

### Taper Plus Advantages



- Outstanding runout accuracy for longer tool life
- Vibration dampening for increased productivity
- High rigidity for smooth and stable cutting
- Interchangeable between standard and dual face contact spindles
- 53% more surface area contact than just the taper alone

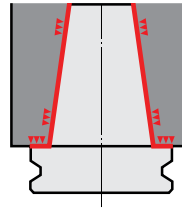

SK Collet Chucks

### Taper Plus - CAT50 SK6

Part Number	Collet Series	Collet Range	Wrench	L	ℓ	ℓ1	C	C1	Back Up Screw	Figure
NCAT50-SK6C-105U	SK6	0.028 - 0.236"	SKL-6W	4.134"	2.756"	3.384"	0.768"	2.750"	SKG6-6HG	2
NCAT50-SK6C-165U	SK6	0.028 - 0.236"	SKL-6W	6.496"	2.441"	5.118"	0.768"	1.260"	SKG6-6HG	2
NCAT50-SK6C-195U	SK6	0.028 - 0.236"	SKL-6W	7.677"	2.362"	6.299"	0.768"	1.181"	SKG6-6HG	3

### Taper Plus - CAT50 SK10

Part Number	Collet Series	Collet Range	Wrench	L	ℓ	ℓ1	C	C1	Back Up Screw 4mm+ (.157"+)	Back Up Screw 6mm+ (.236"+)	Figure
NCAT50-SK10C-105U	SK10	0.069 - 0.394"	SKL-10	4.138"	2.362"	3.384"	1.083"	2.750"	SKG10-10HGA	SKG10-10HG	2
NCAT50-SK10C-165U	SK10	0.069 - 0.394"	SKL-10	6.496"	2.953"	5.118"	1.083"	1.260"	SKG10-10HGA	SKG10-10HG	2
NCAT50-SK10C-195U	SK10	0.069 - 0.394"	SKL-10	7.677"	2.953"	6.299"	1.083"	1.417"	SKG10-10HGA	SKG10-10HG	3
NCAT50-SK10C-225U	SK10	0.069 - 0.394"	SKL-10	8.858"	2.953"	7.677"	1.083"	1.575"	SKG10-10HGA	SKG10-10HG	3

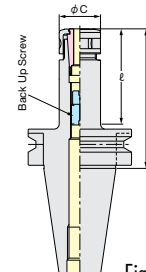

Fig. 1

### Taper Plus - CAT50 SK16

Part Number	Collet Series	Collet Range	Wrench	L	ℓ	ℓ1	C	C1	Back Up Screw 5mm+ (.197"+)	Back Up Screw 10mm+ (.394"+)	Figure
NCAT50-SK16C-105U	SK16	0.108 - 0.630"	9HC16	4.138"	3.384"	2.756"	1.575"	2.750"	SKG16-12HGA	SKG16-12HG	2
NCAT50-SK16C-165U	SK16	0.108 - 0.630"	9HC16	6.496"	5.118"	5.746"	1.575"	2.750"	SKG16-12HGA	SKG16-12HG	2
NCAT50-SK16C-195U	SK16	0.108 - 0.630"	9HC16	7.677"	6.496"	6.927"	1.575"	2.750"	SKG16-12HGA	SKG16-12HG	2

### Taper Plus - CAT50 SK20

Part Number	Collet Series	Collet Range	Wrench	L	ℓ	ℓ1	C	C1	Back Up Screw	Figure
NCAT50-SK20C-105U-IDU*	SK20	0.138 - 0.787"	9HC22	4.134"	n/a	2.756"	1.909"	n/a	SKG20-18HG	2
NCAT50-SK20C-165U-IDU*	SK20	0.138 - 0.787"	9HC22	6.496"	n/a	5.746"	1.909"	n/a	SKG20-18HG	2

Note: \*-IDU\* type holders have a pre-machined counter-bore on the drive key to accept Balluff BIS-C122-04/L RFID chips (10 X 4.5mm size)

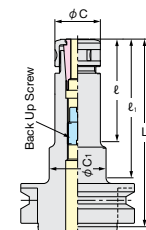

Fig. 2

### Taper Plus - CAT50 SK25

Part Number	Collet Series	Collet Range	Wrench	L	ℓ	ℓ1	C	C1	Back Up Screw	Figure
NCAT50-SK25C-105U	SK25	0.630 - 1.000"	9HC22	4.134"	2.559"	3.384"	2.165"	2.750"	SKG25-24HG	2
NCAT50-SK25C-165U	SK25	0.630 - 1.000"	9HC22	6.496"	4.921"	5.746"	2.165"	2.750"	SKG25-24HG	2
NCAT50-SK25C-195U	SK25	0.630 - 1.000"	9HC22	7.677"	6.102"	6.927"	2.165"	2.750"	SKG25-24HG	2

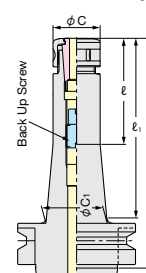

Fig. 3



SK Collets  
Page 30



Wrench  
Page 36



Back-up  
Screw  
Page 37



Coolant-thru  
Nut  
Page 35

# Taper Plus BT SK Collet Chucks

## Taper Plus Advantages

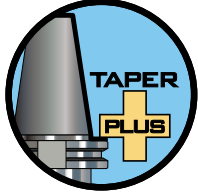

- Outstanding runout accuracy for longer tool life
- Vibration dampening for increased productivity
- High rigidity for smooth and stable cutting
- Interchangeable between standard and dual face contact spindles
- 53% more surface area contact than just the taper alone

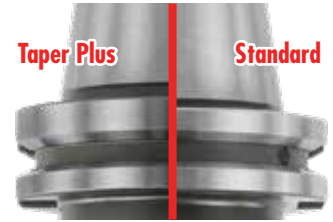
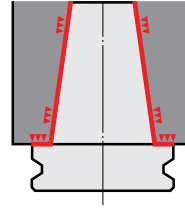

## Taper Plus - BT30 SK6

Part Number	Collet Series	Collet Range	Wrench	L	ℓ	ℓ1	C	C1	Back Up Screw	Figure
NBT30-SK6C-60	SK6	0.028 - 0.236"	SKL-6W	2.362"	1.299"	n/a	0.768"	0.768"	SKG6-6HG	1
NBT30-SK6C-90	SK6	0.028 - 0.236"	SKL-6W	3.543"	2.205"	2.559"	0.768"	1.260"	SKG6-6HG	2
NBT30-SK6C-120	SK6	0.028 - 0.236"	SKL-6W	4.724"	2.441"	3.740"	0.768"	1.260"	SKG6-6HG	2

## Taper Plus - BT30 SK10

Part Number	Collet Series	Collet Range	Wrench	L	ℓ	ℓ1	C	C1	Back Up Screw 4mm+ (.157"+)	Back Up Screw 6mm+ (.236"+)	Figure
NBT30-SK10C-45	SK10	0.069 - 0.394"	SKL-10	1.772"	0.866"	n/a	1.083"	1.083"	SKG10-10HGA	SKG10-10HG	1
NBT30-SK10C-60	SK10	0.069 - 0.394"	SKL-10	2.362"	1.378"	n/a	1.083"	1.083"	SKG10-10HGA	SKG10-10HG	1
NBT30-SK10C-75	SK10	0.069 - 0.394"	SKL-10	2.953"	1.969"	n/a	1.083"	1.083"	SKG10-10HGA	SKG10-10HG	1
NBT30-SK10C-90	SK10	0.069 - 0.394"	SKL-10	3.543"	2.559"	n/a	1.083"	1.083"	SKG10-10HGA	SKG10-10HG	1
NBT30-SK10C-120	SK10	0.069 - 0.394"	SKL-10	4.724"	3.740"	n/a	1.083"	1.083"	SKG10-10HGA	SKG10-10HG	1

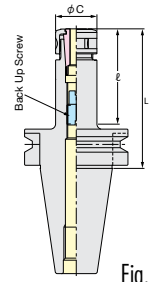

Fig. 1

## Taper Plus - BT30 SK16

Part Number	Collet Series	Collet Range	Wrench	L	ℓ	ℓ1	C	C1	Back Up Screw 5mm+ (.197"+)	Back Up Screw 10mm+ (.394"+)	Figure
NBT30-SK16C-60	SK16	0.108 - 0.630"	9HC16	2.362"	1.457"	n/a	1.575"	1.575"	n/a	SKG16-12HGE	1
NBT30-SK16C-75	SK16	0.108 - 0.630"	9HC16	2.953"	2.047"	n/a	1.575"	1.575"	SKG16-10HGA	SKG16-10HG	1
NBT30-SK16C-90	SK16	0.108 - 0.630"	9HC16	3.543"	2.638"	n/a	1.575"	1.575"	SKG16-12HGA	SKG16-12HG	1
NBT30-SK16C-120	SK16	0.108 - 0.630"	9HC16	4.724"	3.819"	n/a	1.575"	1.575"	SKG16-12HGA	SKG16-12HG	1

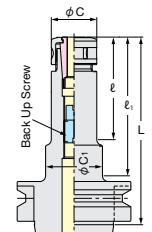

Fig. 2

## Taper Plus - BT30 SK20

Part Number	Collet Series	Collet Range	Wrench	L	ℓ	ℓ1	C	C1	Back Up Screw	Figure
NBT30-SK20-60	SK20	0.138 - 0.787"	9HC22	2.362"	1.496"	n/a	1.909"	1.909"	SKG-12S	1
NBT30-SK20C-75	SK20	0.138 - 0.787"	9HC22	2.953"	2.087"	n/a	1.909"	1.909"	SKG20-12HGE	1
NBT30-SK20C-90	SK20	0.138 - 0.787"	9HC22	3.543"	2.677"	n/a	1.909"	1.909"	SKG20-12HG	1

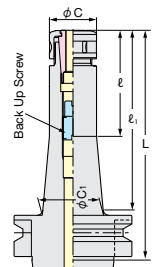

Fig. 3

## Taper Plus - BT30 SK25

Part Number	Collet Series	Collet Range	Wrench	L	ℓ	ℓ1	C	C1	Back Up Screw	Figure
NBT30-SK25-90	SK25	0.630 - 1.000"	9HC22	3.543"	2.638"	n/a	2.165"	2.165"	SKG25-24HG	1





## Taper Plus BT SK Collet Chucks

### Taper Plus Advantages

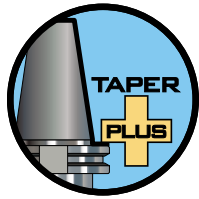

- Outstanding runout accuracy for longer tool life
- Vibration dampening for increased productivity
- High rigidity for smooth and stable cutting
- Interchangeable between standard and dual face contact spindles
- 53% more surface area contact than just the taper alone

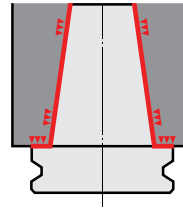

SK Collet Chucks

### Taper Plus - BT40 SK6

Part Number	Collet Series	Collet Range	Wrench	L	ℓ	ℓ1	C	C1	Back Up Screw	Figure
NBT40-SK6C-60	SK6	0.028 - 0.236"	SKL-6W	2.362"	1.181"	n/a	0.768"	0.768"	SKG6-6HG	1
NBT40-SK6C-90	SK6	0.028 - 0.236"	SKL-6W	3.543"	2.008"	2.362"	0.768"	1.260"	SKG6-6HG	2
NBT40-SK6C-120	SK6	0.028 - 0.236"	SKL-6W	4.724"	2.362"	3.543"	0.768"	1.260"	SKG6-6HG	2
NBT40-SK6C-150	SK6	0.028 - 0.236"	SKL-6W	5.906"	2.362"	4.724"	0.768"	0.984"	SKG6-6HG	3

### Taper Plus - BT40 SK10

Part Number	Collet Series	Collet Range	Wrench	L	ℓ	ℓ1	C	C1	Back Up Screw 4mm+ (.157"+)	Back Up Screw 6mm+ (.236"+)	Figure
NBT40-SK10C-60	SK10	0.069 - 0.394"	SKL-10	2.362"	1.260"	n/a	1.083"	1.083"	SKG10-10HGA	SKG10-10HG	1
NBT40-SK10C-75	SK10	0.069 - 0.394"	SKL-10	2.953"	1.575"	n/a	1.083"	1.083"	SKG10-10HGA	SKG10-10HG	1
NBT40-SK10C-90	SK10	0.069 - 0.394"	SKL-10	3.543"	1.890"	2.362"	1.083"	1.575"	SKG10-10HGA	SKG10-10HG	2
NBT40-SK10C-120	SK10	0.069 - 0.394"	SKL-10	4.724"	2.874"	3.543"	1.083"	1.575"	SKG10-10HGA	SKG10-10HG	2
NBT40-SK10C-150	SK10	0.069 - 0.394"	SKL-10	5.906"	2.874"	4.646"	1.083"	1.358"	SKG10-10HGA	SKG10-10HG	3
NBT40-SK10C-180	SK10	0.069 - 0.394"	SKL-10	7.087"	2.874"	5.827"	1.083"	1.535"	SKG10-10HGA	SKG10-10HG	3
NBT40-SK10C-200	SK10	0.069 - 0.394"	SKL-10	7.874"	2.874"	6.614"	1.083"	1.535"	SKG10-10HGA	SKG10-10HG	3
NBT40-SK10C-250	SK10	0.069 - 0.394"	SKL-10	9.843"	2.874"	8.583"	1.083"	1.535"	SKG10-10HGA	SKG10-10HG	3

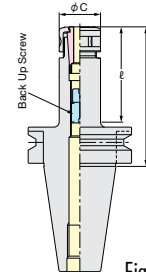

Fig. 1

### Taper Plus - BT40 SK16

Part Number	Collet Series	Collet Range	Wrench	L	ℓ	ℓ1	C	C1	Back Up Screw 5mm+ (.197"+)	Back Up Screw 10mm+ (.394"+)	Figure
NBT40-SK16C-60	SK16	0.108 - 0.630"	9HC16	2.362"	1.260"	n/a	1.575"	1.575"	SKG16-10HGA	SKG16-10HG	1
NBT40-SK16C-75	SK16	0.108 - 0.630"	9HC16	2.953"	1.772"	n/a	1.575"	1.575"	SKG16-12HGA	SKG16-12HG	1
NBT40-SK16C-90	SK16	0.108 - 0.630"	9HC16	3.543"	2.283"	n/a	1.575"	1.575"	SKG16-12HGA	SKG16-12HG	1
NBT40-SK16C-120	SK16	0.108 - 0.630"	9HC16	4.724"	3.465"	n/a	1.575"	1.575"	SKG16-12HGA	SKG16-12HG	1
NBT40-SK16C-150	SK16	0.108 - 0.630"	9HC16	5.906"	4.646"	n/a	1.575"	1.575"	SKG16-12HGA	SKG16-12HG	1
NBT40-SK16C-180	SK16	0.108 - 0.630"	9HC16	7.087"	5.823"	n/a	1.575"	1.575"	SKG16-12HGA	SKG16-12HG	1
NBT40-SK16C-200	SK16	0.108 - 0.630"	9HC16	7.874"	6.614"	n/a	1.575"	1.575"	SKG16-12HGA	SKG16-12HG	1
NBT40-SK16C-250	SK16	0.108 - 0.630"	9HC16	9.843"	8.583"	n/a	1.575"	1.575"	SKG16-12HGA	SKG16-12HG	1

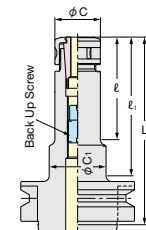

Fig. 2

### Taper Plus - BT40 SK25

Part Number	Collet Series	Collet Range	Wrench	L	ℓ	ℓ1	C	C1	Back Up Screw	Figure
NBT40-SK25C-75	SK25	0.630 - 1.000"	9HC22	2.953"	1.850"	n/a	2.165"	2.165"	SKG25-24HGE	1
NBT40-SK25C-90	SK25	0.630 - 1.000"	9HC22	3.543"	2.402"	n/a	2.165"	2.165"	SKG25-18HGD	1
NBT40-SK25C-120	SK25	0.630 - 1.000"	9HC22	4.724"	3.583"	n/a	2.165"	2.165"	SKG25-24HG	1

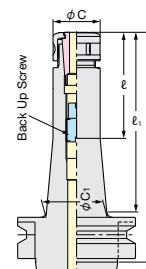

Fig. 3



SK Collets  
Page 30



Wrench  
Page 36



Back-up  
Screw  
Page 37



Coolant-thru  
Nut  
Page 35

Taper Plus CAT Slim Chuck Coolant High-Speed

Taper Plus Advantages

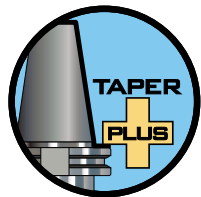

- Outstanding runout accuracy for longer tool life
- Vibration dampening for increased productivity
- High rigidity for smooth and stable cutting
- Interchangeable between standard and dual face contact spindles
- 53% more surface area contact than just the taper alone

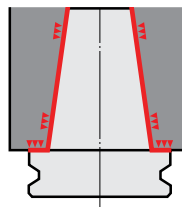

Taper Plus - CAT40 SK6-P

Part Number	Collet Series	Collet Range	Wrench	L	ℓ1	C	C1	Back Up Screw
NCAT40-SK6C-90UP	SK6	0.028 - 0.236"	GH6	3.543"	2.165"	0.768"	1.750"	SKG-8
NCAT40-SK6C-120UP	SK6	0.028 - 0.236"	GH6	4.724"	2.441"	0.768"	1.260"	SKG-8
NCAT40-SK6C-150UP	SK6	0.028 - 0.236"	GH6	5.906"	2.362"	0.768"	0.984"	SKG-8

Taper Plus - CAT40 SK10-P

Part Number	Collet Series	Collet Range	Wrench	L	ℓ1	C	C1	Back Up Screw
NCAT40-SK10C-90UP	SK10	0.069 - 0.394"	GH10	3.543"	1.969"	1.083"	1.750"	SKG10-10HG
NCAT40-SK10C-120UP	SK10	0.069 - 0.394"	GH10	4.724"	2.756"	1.083"	1.260"	SKG10-10HG
NCAT40-SK10C-150UP	SK10	0.069 - 0.394"	GH10	5.906"	2.874"	1.083"	1.343"	SKG10-10HG



Taper Plus - CAT40 SK16-P

Part Number	Collet Series	Collet Range	Wrench	L	ℓ1	C	C1	Back Up Screw
NCAT40-SK16C-60UP	SK16	0.108 - 0.630"	GH16	2.362"	1.612"	1.575"	1.575"	n/a
NCAT40-SK16C-90UP	SK16	0.108 - 0.630"	GH16	3.543"	2.165"	1.575"	1.750"	SKG-18L
NCAT40-SK16C-120UP	SK16	0.108 - 0.630"	GH16	4.724"	3.346"	1.575"	1.750"	SKG-18L
NCAT40-SK16C-150UP	SK16	0.108 - 0.630"	GH16	5.906"	4.526"	1.575"	1.750"	SKG-18L

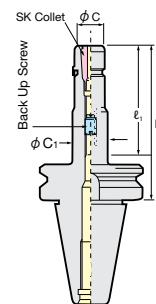

Taper Plus - CAT40 SK20-P

Part Number	Collet Series	Collet Range	Wrench	L	ℓ1	C	C1	Back Up Screw
NCAT40-SK20C-65UP-IDU*	SK20	0.138 - 0.787"	GH20	2.559"	1.809"	1.909"	n/a	SKG20-12HG
NCAT40-SK20C-90UP-IDU*	SK20	0.138 - 0.787"	GH20	3.543"	2.793"	1.909"	n/a	SKG20-18HG
NCAT40-SK20C-120UP-IDU*	SK20	0.138 - 0.787"	GH20	4.724"	3.974"	1.909"	n/a	SKG20-18HG
NCAT40-SK20C-150UP-IDU*	SK20	0.138 - 0.787"	GH20	5.906"	5.516"	1.909"	n/a	SKG20-18HG

Note: \*"-IDU" type holders have a pre-machined counter-bore on the drive key to accept Balluff BIS-C122-04/L RFID chips (10 X 4.5mm size)

Taper Plus - CAT40 SK25-P

Part Number	Collet Series	Collet Range	Wrench	L	ℓ1	C	C1	Back Up Screw
NCAT40-SK25C-90UP	SK25	0.630 - 1.000"	GH25	3.543"	2.793"	2.165"	2.165"	SKG-28
NCAT40-SK25C-120UP	SK25	0.630 - 1.000"	GH25	4.724"	3.974"	2.165"	2.165"	SKG-28



## Taper Plus CAT Slim Chuck Coolant High-Speed

### Taper Plus Advantages

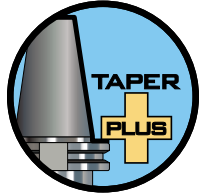

- Outstanding runout accuracy for longer tool life
- Vibration dampening for increased productivity
- High rigidity for smooth and stable cutting
- Interchangeable between standard and dual face contact spindles
- 53% more surface area contact than just the taper alone

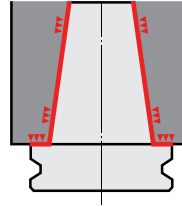

SK Collet Chucks

### Taper Plus - CAT50 SK6-P

Part Number	Collet Series	Collet Range	Wrench	L	ℓ1	C	C1	Back Up Screw
NCAT50-SK6C-105UP	SK6	0.028 - 0.236"	GH6	4.134"	2.362"	0.768"	2.750"	SKG6-6HG
NCAT50-SK6C-165UP	SK6	0.028 - 0.236"	GH6	6.496"	2.441"	0.768"	1.260"	SKG6-6HG

### Taper Plus - CAT50 SK10-P

Part Number	Collet Series	Collet Range	Wrench	L	ℓ1	C	C1	Back Up Screw
NCAT50-SK10C-105UP	SK10	0.069 - 0.394"	GH10	4.134"	2.756"	1.083"	2.750"	SKG10-10HG
NCAT50-SK10C-165UP	SK10	0.069 - 0.394"	GH10	6.496"	2.953"	1.083"	1.260"	SKG10-10HG

### Taper Plus - CAT50 SK16-P

Part Number	Collet Series	Collet Range	Wrench	L	ℓ1	C	C1	Back Up Screw
NCAT50-SK16C-105UP	SK16	0.108 - 0.630"	GH16	4.134"	2.756"	1.575"	2.750"	SKG-18L
NCAT50-SK16C-165UP	SK16	0.108 - 0.630"	GH16	6.496"	3.740"	1.575"	2.750"	SKG-18L

### Taper Plus - CAT50 SK25-P

Part Number	Collet Series	Collet Range	Wrench	L	ℓ1	C	C1	Back Up Screw
NCAT50-SK25C-105UP	SK25	0.630 - 1.000"	GH25	4.134"	3.384"	2.165"	2.165"	SKG-28
NCAT50-SK25C-165UP	SK25	0.630 - 1.000"	GH25	6.496"	5.746"	2.165"	2.165"	SKG-28

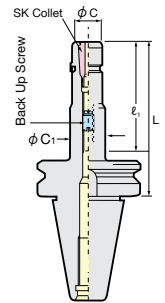

SK Collets  
Page 30



Wrench  
Page 36



Back-up  
Screw  
Page 37



Coolant-thru  
Nut  
Page 35

Taper Plus BT Slim Chuck Coolant High-Speed

Taper Plus Advantages

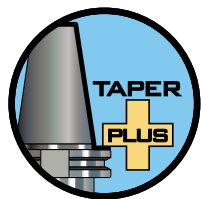

- Outstanding runout accuracy for longer tool life
- Vibration dampening for increased productivity
- High rigidity for smooth and stable cutting
- Interchangeable between standard and dual face contact spindles
- 53% more surface area contact than just the taper alone

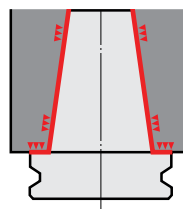

Taper Plus - BT30 SK6-P

Part Number	Collet Series	Collet Range	Wrench	L	ℓ1	C	C1	Back Up Screw
NBT30-SK6C-60P	SK6	0.028 - 0.236"	GH6	2.362"	1.299"	0.768"	0.768"	SKG6-6HG
NBT30-SK6C-90P	SK6	0.028 - 0.236"	GH6	3.543"	2.559"	0.768"	1.260"	SKG6-6HG
NBT30-SK6C-120P	SK6	0.028 - 0.236"	GH6	4.724"	3.839"	0.768"	1.260"	SKG6-6HG

Taper Plus - BT30 SK10-P

Part Number	Collet Series	Collet Range	Wrench	L	ℓ1	C	C1	Back Up Screw
NBT30-SK10C-45P	SK10	0.069 - 0.394"	GH10	1.772"	0.866"	1.083"	1.083"	SKG10-10HG
NBT30-SK10C-60P	SK10	0.069 - 0.394"	GH10	2.362"	1.378"	1.083"	1.083"	SKG10-10HG
NBT30-SK10C-75P	SK10	0.069 - 0.394"	GH10	2.953"	1.969"	1.083"	1.083"	SKG10-10HG
NBT30-SK10C-90P	SK10	0.069 - 0.394"	GH10	3.543"	2.559"	1.083"	1.083"	SKG10-10HG
NBT30-SK10C-120P	SK10	0.069 - 0.394"	GH10	4.724"	3.858"	1.083"	1.083"	SKG10-10HG

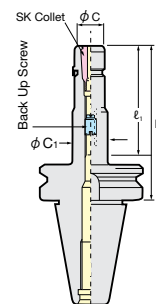

Taper Plus - BT30 SK16-P

Part Number	Collet Series	Collet Range	Wrench	L	ℓ1	C	C1	Back Up Screw
NBT30-SK16C-60P	SK16	0.108 - 0.630"	GH16	2.362"	1.457"	1.575"	1.575"	SKG16-12HGE
NBT30-SK16C-75P	SK16	0.108 - 0.630"	GH16	2.953"	2.047"	1.575"	1.575"	SKG16-10HG
NBT30-SK16C-90P	SK16	0.108 - 0.630"	GH16	3.543"	2.638"	1.575"	1.575"	SKG16-12HG
NBT30-SK16C-120P	SK16	0.108 - 0.630"	GH16	4.724"	3.831"	1.575"	1.575"	SKG16-12HG

Taper Plus - BT30 SK20-P

Part Number	Collet Series	Collet Range	Wrench	L	ℓ1	C	C1	Back Up Screw
NBT30-SK20C-75P	SK20	0.138 - 0.787"	GH20	2.953"	2.087	1.909"	1.909"	SKG20-12HGE
NBT30-SK20C-90P	SK20	0.138 - 0.787"	GH20	3.543"	2.677	1.909"	1.909"	SKG20-12HG

Taper Plus - BT30 SK25-P

Part Number	Collet Series	Collet Range	Wrench	L	ℓ1	C	C1	Back Up Screw
NBT30-SK25-90P	SK25	0.630 - 1.000"	GH25	3.543"	2.638"	2.165"	2.165"	SKG-12





## Taper Plus BT Slim Chuck Coolant High-Speed

### Taper Plus Advantages

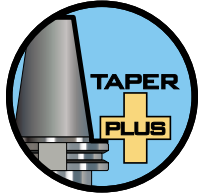

- Outstanding runout accuracy for longer tool life
- Vibration dampening for increased productivity
- High rigidity for smooth and stable cutting
- Interchangeable between standard and dual face contact spindles
- 53% more surface area contact than just the taper alone

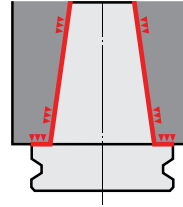

### Taper Plus - BT40 SK6-P

Part Number	Collet Series	Collet Range	Wrench	L	ℓ1	C	C1	Back Up Screw
NBT40-SK6C-60P	SK6	0.028 - 0.236"	GH6	2.362"	1.181"	0.768"	0.768"	SKG6-6HG
NBT40-SK6C-90P	SK6	0.028 - 0.236"	GH6	3.543"	2.362"	0.768"	1.260"	SKG6-6HG
NBT40-SK6C-120P	SK6	0.028 - 0.236"	GH6	4.724"	3.543"	0.768"	1.260"	SKG6-6HG
NBT40-SK6C-150P	SK6	0.028 - 0.236"	GH6	5.906"	5.236"	0.768"	0.984"	SKG6-6HG

### Taper Plus - BT40 SK10-P

Part Number	Collet Series	Collet Range	Wrench	L	ℓ1	C	C1	Back Up Screw
NBT40-SK10C-60P	SK10	0.069 - 0.394"	GH10	2.362"	1.260"	1.083"	1.083"	SKG10-10HG
NBT40-SK10C-75P	SK10	0.069 - 0.394"	GH10	2.953"	1.772"	1.083"	1.083"	SKG10-10HG
NBT40-SK10C-90P	SK10	0.069 - 0.394"	GH10	3.543"	2.362"	1.083"	1.575"	SKG10-10HG
NBT40-SK10C-120P	SK10	0.069 - 0.394"	GH10	4.724"	3.543"	1.083"	1.575"	SKG10-10HG
NBT40-SK10C-150P	SK10	0.069 - 0.394"	GH10	5.906"	4.646"	1.083"	1.358"	SKG10-10HG

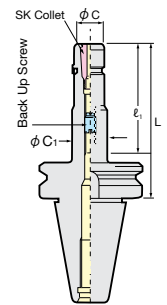

### Taper Plus - BT40 SK16-P

Part Number	Collet Series	Collet Range	Wrench	L	ℓ1	C	C1	Back Up Screw
NBT40-SK16C-60P	SK16	0.108 - 0.630"	GH16	2.362"	1.260"	1.575"	1.575"	SKG16-10HG
NBT40-SK16C-75P	SK16	0.108 - 0.630"	GH16	2.953"	1.693"	1.575"	1.575"	SKG16-12HG
NBT40-SK16C-90P	SK16	0.108 - 0.630"	GH16	3.543"	2.283"	1.575"	1.575"	SKG16-12HG
NBT40-SK16C-120P	SK16	0.108 - 0.630"	GH16	4.724"	3.465"	1.575"	1.575"	SKG16-12HG
NBT40-SK16C-150P	SK16	0.108 - 0.630"	GH16	5.906"	4.646"	1.575"	1.575"	SKG16-12HG

### Taper Plus - BT40 SK25-P

Part Number	Collet Series	Collet Range	Wrench	L	ℓ1	C	C1	Back Up Screw
NBT40-SK25C-75P	SK25	0.630 - 1.000"	GH25	2.953"	1.850"	2.165"	2.165"	SKG25-18HGD
NBT40-SK25C-90P	SK25	0.630 - 1.000"	GH25	3.543"	2.402"	2.165"	2.165"	SKG25-18HGD
NBT40-SK25C-120P	SK25	0.630 - 1.000"	GH25	4.724"	3.583"	2.165"	2.165"	SKG25-24HG



## SK6 Collets

### SK6 Collets

Size range: 0.7mm - 6.0mm (0.028 - 0.236")

#### Metric

Part Number	Collapse Range (mm)	Collapse Range (in)	Figure
SK6-0.8	0.7 - 0.8	0.027 - 0.031"	1
SK6-1	0.9 - 1.0	0.035 - 0.039"	1
SK6-1.25	1.15 - 1.25	0.045 - 0.049"	1
SK6-1.5	1.3 - 1.5	0.051 - 0.059"	1
SK6-1.75	1.5 - 1.75	0.059 - 0.068"	1
SK6-2	1.8 - 2.0	0.070 - 0.078"	1
SK6-2.25	2.05 - 2.25	0.080 - 0.088"	1
SK6-2.5	2.3 - 2.5	0.090 - 0.098"	1
SK6-2.75	2.55 - 2.75	0.100 - 0.108"	1
SK6-3	2.8 - 3.0	0.110 - 0.118"	1
SK6-3.5	3.0 - 3.5	0.118 - 0.137"	2
SK6-4	3.5 - 4.0	0.137 - 0.157"	2
SK6-4.5	4.0 - 4.5	0.157 - 0.177"	2
SK6-5	4.5 - 5.0	0.177 - 0.196"	2
SK6-5.5	5.0 - 5.5	0.196 - 0.216"	2
SK6-6	5.5 - 6.0	0.216 - 0.236"	2
SK6-SET-16-MM	16 Piece SK6 Collet Set - 0.7mm - 6.0mm		

#### Inch

Part Number	Size	Figure
SK6-1/8A	0.125"	1
SK6-3/16A	0.187"	1

These inch size collets do not collapse.

#### Dimensional Data

Collet Series	C1	L1	Collapse Range (D1)
SK6	0.394" (10mm)	0.969" (24.6mm)	0.027 - 0.236" (0.7 - 6.0mm)

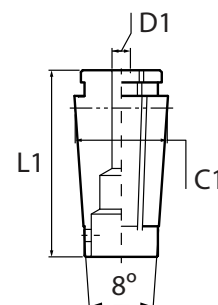

Figure 1

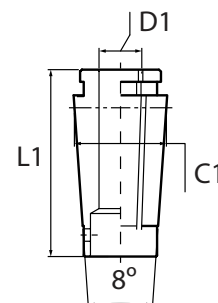

Figure 2

### SK6 Collet Rack



Part Number	Description
RACK-ER11/SK6	SK6 collet rack, 35 collets capacity

Note: SK Collet Drill Chart available on page 248 in the Technical section.



## SK10 Collets

### SK10 Collets

Size range: 1.75mm - 10.0mm (0.069 - 0.394")

#### Metric

Part Number	Collapse Range (mm)	Collapse Range (in)	Figure
SK10-2	1.75 - 2.0	0.068 - 0.078"	1
SK10-2.25	2.0 - 2.25	0.078 - 0.088"	1
SK10-2.5	2.25 - 2.5	0.088 - 0.098"	1
SK10-2.75	2.5 - 2.75	0.098 - 0.108"	1
SK10-3	2.75 - 3.0	0.108 - 0.118"	1
SK10-3.5	3.0 - 3.5	0.118 - 0.137"	1
SK10-4	3.5 - 4.0	0.137 - 0.157"	1
SK10-4.5	4.0 - 4.5	0.157 - 0.177"	1
SK10-5	4.5 - 5.0	0.177 - 0.196"	2
SK10-5.5	5.0 - 5.5	0.196 - 0.216"	2
SK10-6	5.5 - 6.0	0.216 - 0.236"	2
SK10-6.5	6.0 - 6.5	0.236 - 0.255"	2
SK10-7	6.5 - 7.0	0.255 - 0.275"	2
SK10-7.5	7.0 - 7.5	0.275 - 0.295"	2
SK10-8	7.5 - 8.0	0.295 - 0.314"	2
SK10-8.5	8.0 - 8.5	0.314 - 0.334"	2
SK10-9	8.5 - 9.0	0.334 - 0.354"	2
SK10-9.5	9.0 - 9.5	0.354 - 0.374"	2
SK10-10	9.5 - 10.0	0.374 - 0.394"	2
SK10-SET-19-MM	19 Piece SK10 Collet Set - 1.75mm - 10.0mm		

#### Metric - Coolant-Thru

Up to 1000 psi capable.

Part Number	Size	Figure
SK10-3AC	3mm	2
SK10-4AC	4mm	2
SK10-5AC	5mm	2
SK10-6AC	6mm	2
SK10-7AC	7mm	2
SK10-8AC	8mm	2
SK10-9AC	9mm	2
SK10-10AC	10mm	2
SK10-SET-08-AC-MM	8 Piece SK10 Coolant Collet Set - 3.0mm - 10.0mm	

*Note:*  
Cutter must be inserted to the full length of the collet.

#### Inch

Part Number	Size	Figure
SK10-1/8A	0.125"	1
SK10-3/16A	0.187"	1
SK10-1/4A	0.250"	1
SK10-5/16A	0.312"	1
SK10-3/8A	0.375"	1
SK10-SET-05-A	5 Piece SK10 Collet Set - 1/8 - 3/8" x16th	

These inch size collets do not collapse.

#### Dimensional Data

Collet Series	C1	L1	Collapse Range (D1)
SK10	0.591" (15mm)	1.201" (30.5mm)	0.069 - 0.394" (1.75 - 10.0mm)

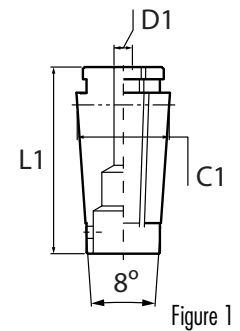

Figure 1

#### Inch - Coolant-Thru

Up to 1000 psi capable.

Part Number	Size	Figure
SK10-1/8AC	0.125"	2
SK10-3/16AC	0.187"	2
SK10-1/4AC	0.250"	2
SK10-5/16AC	0.312"	2
SK10-3/8AC	0.375"	2

*Note:* AC-type collets are mechanically sealing and can handle coolant through the tool up to 1000 psi. No additional coolant disk or nut is required when using these collets.

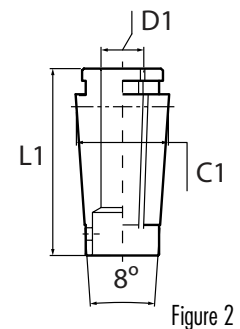

Figure 2

### SK10 Collet Rack



Part Number	Description
RACK-ER16/SK10	SK10 collet rack, 24 collets capacity

*Note:* SK Collet Drill Chart available on page 248 in the Technical section.



SK Collets  
Page 30



Wrench  
Page 36



Back-up  
Screw  
Page 37



Coolant-thru  
Nut  
Page 35

## SK16 Collets

### SK16 Collets

Size range: 2.75mm - 16.0mm (0.108 - 0.630")

#### Metric

Part Number	Collapse Range (mm)	Collapse Range (in)	Figure
SK16-3	2.75 - 3.0	0.108 - 0.118"	1
SK16-3.5	3.0 - 3.5	0.118 - 0.137"	1
SK16-4	3.5 - 4.0	0.137 - 0.157"	1
SK16-4.5	4.0 - 4.5	0.157 - 0.177"	1
SK16-5	4.5 - 5.0	0.177 - 0.196"	1
SK16-5.5	5.0 - 5.5	0.196 - 0.216"	1
SK16-6	5.5 - 6.0	0.216 - 0.236"	1
SK16-6.5	6.0 - 6.5	0.236 - 0.255"	1
SK16-7	6.5 - 7.0	0.255 - 0.275"	1
SK16-7.5	7.0 - 7.5	0.275 - 0.295"	1
SK16-8	7.5 - 8.0	0.295 - 0.314"	1
SK16-8.5	8.0 - 8.5	0.314 - 0.334"	1
SK16-9	8.5 - 9.0	0.334 - 0.354"	1
SK16-9.5	9.0 - 9.5	0.354 - 0.374"	1
SK16-10	9.5 - 10.0	0.374 - 0.394"	1
SK16-10.5	10.0 - 10.5	0.394 - 0.413"	2
SK16-11	10.5 - 11.0	0.413 - 0.433"	2
SK16-11.5	11.0 - 11.5	0.433 - 0.452"	2
SK16-12	11.5 - 12.0	0.452 - 0.472"	2
SK16-12.5	12.0 - 12.5	0.472 - 0.492"	2
SK16-13	12.5 - 13.0	0.492 - 0.511"	2
SK16-13.5	13.0 - 13.5	0.511 - 0.531"	2
SK16-14	13.5 - 14.0	0.531 - 0.551"	2
SK16-14.5	14.0 - 14.5	0.551 - 0.570"	2
SK16-15	14.5 - 15.0	0.570 - 0.590"	2
SK16-15.5	15.0 - 15.5	0.590 - 0.610"	2
SK16-16	15.5 - 16.0	0.610 - 0.630"	2
SK16-SET-27-MM	27 Piece SK16 Collet Set - 2.75mm - 16.0mm		

#### Inch

Part Number	Size	Figure
SK16-1/8A	0.125"	1
SK16-3/16A	0.187"	1
SK16-1/4A	0.250"	1
SK16-5/16A	0.312"	1
SK16-3/8A	0.375"	1
SK16-7/16A	0.437"	1
SK16-1/2A	0.500"	1
SK16-9/16A	0.562"	1
SK16-5/8A	0.625"	1
SK16-SET-09-A	9 Piece SK16 Collet Set - 1/8 - 5/8" X16th	

These inch size collets do not collapse.

#### Dimensional Data

Collet Series	C1	L1	Collapse Range (D1)
SK16	0.945" (24mm)	1.772" (45mm)	0.108 - 0.630" (2.75 - 16.0mm)

#### Metric - Coolant-Thru

Up to 1000 psi capable.

Part Number	Size	Figure
SK16-6AC	6mm	2
SK16-7AC	7mm	2
SK16-8AC	8mm	2
SK16-9AC	9mm	2
SK16-10AC	10mm	2
SK16-11AC	11mm	2
SK16-12AC	12mm	2
SK16-14AC	14mm	2
SK16-16AC	16mm	2

Note:  
Cutter must be inserted to the full length of the collet.

#### Inch - Coolant-Thru

Up to 1000 psi capable.

Part Number	Size	Figure
SK16-7/16AC	0.437"	2
SK16-1/2AC	0.500"	2
SK16-9/16AC	0.562"	2
SK16-5/8AC	0.625"	2

Note: AC-type collets are mechanically sealing and can handle coolant through the tool up to 1000 psi. No additional coolant disk or nut is required when using these collets.

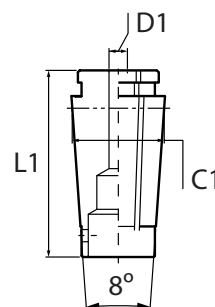

Figure 1

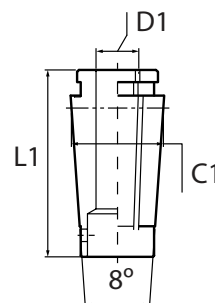

Figure 2

### SK16 Collet Rack



Part Number	Description
RACK-180DA/SK16/ER25	SK16 collet rack, 30 collets capacity

Note: SK Collet Drill Chart available on page 248 in the Technical section.





## SK20 Collets

### SK20 Collets

Size range: 3.5mm - 20.00mm (0.138 - 0.787")

#### Metric

Part Number	Collapse Range (mm)	Collapse Range (in)
SK20-4	3.5 - 4.0	0.137 - 0.157"
SK20-4.5	4.0 - 4.5	0.157 - 0.177"
SK20-5	4.5 - 5.0	0.177 - 0.196"
SK20-5.5	5.0 - 5.5	0.196 - 0.216"
SK20-6	5.5 - 6.0	0.216 - 0.236"
SK20-6.5	6.0 - 6.5	0.236 - 0.255"
SK20-7	6.5 - 7.0	0.255 - 0.275"
SK20-7.5	7.0 - 7.5	0.275 - 0.295"
SK20-8	7.5 - 8.0	0.295 - 0.314"
SK20-8.5	8.0 - 8.5	0.314 - 0.334"
SK20-9	8.5 - 9.0	0.334 - 0.354"
SK20-9.5	9.0 - 9.5	0.354 - 0.374"
SK20-10	9.5 - 10.0	0.374 - 0.394"
SK20-10.5	10.0 - 10.5	0.394 - 0.413"
SK20-11	10.5 - 11.0	0.413 - 0.433"
SK20-11.5	11.0 - 11.5	0.433 - 0.452"
SK20-12	11.5 - 12.0	0.452 - 0.472"
SK20-12.5	12.0 - 12.5	0.472 - 0.492"
SK20-13	12.5 - 13.0	0.492 - 0.511"
SK20-13.5	13.0 - 13.5	0.511 - 0.531"
SK20-14	13.5 - 14.0	0.531 - 0.551"
SK20-14.5	14.0 - 14.5	0.551 - 0.570"
SK20-15	14.5 - 15.0	0.570 - 0.590"
SK20-15.5	15.0 - 15.5	0.590 - 0.610"
SK20-16	15.5 - 16.0	0.610 - 0.630"
SK20-16.5	16.0 - 16.5	0.630 - 0.649"
SK20-17	16.5 - 17.0	0.649 - 0.669"
SK20-17.5	17.0 - 17.5	0.669 - 0.688"
SK20-18	17.5 - 18.0	0.688 - 0.708"
SK20-18.5	18.0 - 18.5	0.708 - 0.728"
SK20-19	18.5 - 19.0	0.728 - 0.748"
SK20-19.5	19.0 - 19.5	0.748 - 0.767"
SK20-20	19.5 - 20.0	0.767 - 0.787"

#### Inch

Part Number	Size
SK20-1/8A	0.125"
SK20-3/16A	0.187"
SK20-1/4A	0.250"
SK20-5/16A	0.312"
SK20-3/8A	0.375"
SK20-7/16A	0.437"
SK20-1/2A	0.500"
SK20-9/16A	0.562"
SK20-5/8A	0.625"
SK20-3/4A	0.750"

These inch size collets do not collapse.

#### Dimensional Data

Collet Series	C1	L1	Collapse Range (D1)
SK20	1.142" (29mm)	2.126" (54mm)	0.137 - 0.787" (3.5 - 20.0mm)

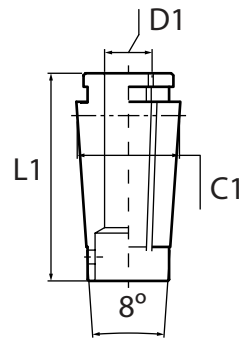

SK Collet Chucks

### Metric - Coolant-Thru

Up to 1000 psi capable.

Part Number	Size	Note:
SK20-12AC	12mm	Cutter must be inserted to the full length of the collet.
SK20-16AC	16mm	
SK20-18AC	18mm	
SK20-20AC	20mm	

### Inch - Coolant-Thru

Up to 1000 psi capable.

Part Number	Size	Note:
SK20-7/16AC	0.437"	AC-type collets are mechanically sealing and can handle coolant through the tool up to 1000 psi. No additional coolant disk or nut is required when using these collets.
SK20-1/2AC	0.500"	
SK20-9/16AC	0.562"	
SK20-5/8AC	0.625"	
SK20-3/4AC	0.750"	

Note: SK Collet Drill Chart available on page 248 in the Technical section.



SK Collets  
Page 30



Wrench  
Page 36



Back-up  
Screw  
Page 37



Coolant-thru  
Nut  
Page 35

## SK25 Collets

### SK25 Collets

Size range: 16.0mm - 25.4mm (0.630 - 1.000")

#### Metric

Part Number	Collapse Range (mm)	Collapse Range (in)
SK25-16.5	16.0 - 16.5	0.630 - 0.649"
SK25-17	16.5 - 17.0	0.649 - 0.669"
SK25-17.5	17.0 - 17.5	0.669 - 0.688"
SK25-18	17.5 - 18.0	0.688 - 0.708"
SK25-18.5	18.0 - 18.5	0.708 - 0.728"
SK25-19	18.5 - 19.0	0.728 - 0.748"
SK25-19.5	19.0 - 19.5	0.748 - 0.767"
SK25-20	19.5 - 20.0	0.767 - 0.787"
SK25-20.5	20.0 - 20.5	0.787 - 0.807"
SK25-21	20.5 - 21.0	0.807 - 0.826"
SK25-21.5	21.0 - 21.5	0.826 - 0.846"
SK25-22	21.5 - 22.0	0.846 - 0.866"
SK25-22.5	22.0 - 22.5	0.866 - 0.885"
SK25-23	22.5 - 23.0	0.885 - 0.905"
SK25-23.5	23.0 - 23.5	0.905 - 0.925"
SK25-24	23.5 - 24.0	0.925 - 0.944"
SK25-24.5	24.0 - 24.5	0.944 - 0.964"
SK25-25	24.5 - 25.0	0.964 - 0.984"
SK25-25.4	25.0 - 25.4	0.984 - 1.000"
SK25-SET-19-MM	19 Piece SK25 Collet Set - 16.0mm - 25.4mm	

#### Inch

Part Number	Size
SK25-3/16A	0.187"
SK25-1/4A	0.250"
SK25-5/16A	0.312"
SK25-3/8A	0.375"
SK25-7/16A	0.437"
SK25-1/2A	0.500"
SK25-5/8A	0.625"
SK25-3/4A	0.750"
SK25-SET-08-A	8 Piece SK25 Collet Set - 3/16 - 3/4" X16th

These inch size collets do not collapse.

#### Dimensional Data

Collet Series	C1	L1	Collapse Range (D1)
SK25	1.378" (35mm)	2.244" (57mm)	0.630 - 1.000" (16.0 - 25.4mm)

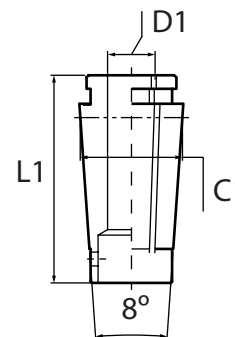

### Metric - Coolant-Thru

Up to 1000 psi capable.

Part Number	Size	Note:
SK25-20AC	20mm	Cutter must be inserted to the full length of the collet.
SK25-25AC	25mm	

### Inch - Coolant-Thru

Up to 1000 psi capable.

Part Number	Size	Note:
SK25-3/4AC	0.750"	AC-type collets are mechanically sealing and can handle coolant through the tool up to 1000 psi. No additional coolant disk or nut is required when using these collets.
SK25-7/8AC	0.875"	

### SK25 Collet Rack



Part Number	Description
RACK-5C/100TG/SK25	SK25 collet rack, 30 pieces capacity

Note: SK Collet Drill Chart available on page 248 in the Technical section.



## SK Coolant Collet System

Collet Chuck	Collet Series	Coolant Nut Part Number	High-Speed Coolant Nut Part Number	Cutting Tool Size	Coolant-Thru Disk Part Number	Slotted Disk Part Number	Disk Wrench Part Number	Blank Disk (machinable) Part Number						
SK6	SK6 range: 0.7 - 6mm [0.027 - 0.236"]	SKN-6WBJ	SKN-6WBJ (GH)	3mm	SKJ6-3C	SKJ6-3	SKJL-6	SKJ6-BLANK						
				4mm	SKJ6-4C	SKJ6-4								
				5mm	SKJ6-5C	SKJ6-5								
				6mm	SKJ6-6C	SKJ6-6								
				1/8"	SKJ6-1/8C	SKJ6-1/8								
				3/16"	SKJ6-3/16C	SKJ6-3/16								
				3mm	SKJ10-3C	SKJ10-3			SKJL-10	SKJ10-BLANK				
4mm	SKJ10-4C	SKJ10-4												
5mm	SKJ10-5C	SKJ10-5												
6mm	SKJ10-6C	SKJ10-6												
8mm	SKJ10-8C	SKJ10-8												
10mm	SKJ10-10C	SKJ10-10												
1/8"	SKJ10-1/8C	SKJ10-1/8												
3/16"	SKJ10-3/16C	SKJ10-3/16												
1/4"	SKJ10-1/4C	SKJ10-1/4												
5/16"	SKJ10-5/16C	SKJ10-5/16												
3/8"	SKJ10-3/8C	SKJ10-3/8												
SK16	SK16 range: 2.75 - 16mm [0.108 - 0.630"]	SKN-16BJ	SKN-16BJ (GH)	6mm	SKJ16-6C	SKJ16-6	SKJL-16	SKJ16-BLANK						
				8mm	SKJ16-8C	SKJ16-8								
				10mm	SKJ16-10C	SKJ16-10								
				12mm	SKJ16-12C	SKJ16-12								
				16mm	SKJ16-16C	SKJ16-16								
				1/4"	SKJ16-1/4C	SKJ16-1/4								
				5/16"	SKJ16-5/16C	SKJ16-5/16								
				3/8"	SKJ16-3/8C	SKJ16-3/8								
				7/16"	SKJ16-7/16C	SKJ16-7/16								
				1/2"	SKJ16-1/2C	SKJ16-1/2								
				9/16"	SKJ16-9/16C	SKJ16-9/16								
				5/8"	SKJ16-5/8C	SKJ16-5/8								
				8mm	SKJ25-8C	SKJ25-8			SKJL-25	SKJ25-BLANK				
				10mm	SKJ25-10C	SKJ25-10								
16mm	SKJ25-16C	SKJ25-16												
17.5mm	SKJ25-17.5C	SKJ25-17.5												
18mm	SKJ25-18C	SKJ25-18												
20mm	SKJ25-20C	SKJ25-20												
25mm	SKJ25-25C	SKJ25-25												
3/16"	SKJ25-3/16C	SKJ25-3/16												
1/4"	SKJ25-1/4C	SKJ25-1/4												
5/16"	SKJ25-5/16C	SKJ25-5/16												
3/8"	SKJ25-3/8C	SKJ25-3/8												
7/16"	SKJ25-7/16C	SKJ25-7/16												
1/2"	SKJ25-1/2C	SKJ25-1/2												
5/8"	SKJ25-5/8C	SKJ25-5/8												
SK25	SK25 range: 16.0 - 25.4mm [0.630 - 1.000"]	SKN-25BJ	SKN-25BJ (GH)	11/16"	SKJ25-11/16C	SKJ25-11/16	SKJL-25	SKJ25-BLANK						
				3/4"	SKJ25-3/4C	SKJ25-3/4								
				13/16"	SKJ25-13/16C	SKJ25-13/16								
				7/8"	SKJ25-7/8C	SKJ25-7/8								
				15/16"	SKJ25-15/16C	SKJ25-15/16								
				1"	SKJ25-1C	SKJ25-1								
				SK20	SK20 range: 3.5mm - 20mm [0.137 - 0.787"]  SKJ Disk Range: 8mm - 20mm 3/16 - 3/4"	SKN-20BJ			SKN-20BJ (GH)	3/8"	SKJ25-3/8C	SKJ25-3/8	SKJL-25	SKJ25-BLANK
										7/16"	SKJ25-7/16C	SKJ25-7/16		
										1/2"	SKJ25-1/2C	SKJ25-1/2		
										5/8"	SKJ25-5/8C	SKJ25-5/8		

## SK Collet Chuck Accessories

### SK Collet Extractor

Part Number	Description
SKR-6	SK6 Collet Extractor
SKR-10	SK10 Collet Extractor
SKR-16	SK16 Collet Extractor
SKR-20	SK20 Collet Extractor
SKR-25	SK25 Collet Extractor



### Replacement Nut for SK Collet Chuck Standard Style

Part Number	Description
SKN-6WB	Nut for SK6 Collet Chuck
SKN-10B	Nut for SK10 Collet Chuck
SKN-16B	Nut for SK16 Collet Chuck
SKN-20B	Nut for SK20 Collet Chuck
SKN-25B	Nut for SK25 Collet Chuck



### High-Speed Style

Part Number	Description
SKN-6WB (GH)	Nut for SK6 High-Speed Collet Chuck
SKN-10B (GH)	Nut for SK10 High-Speed Collet Chuck
SKN-16B (GH)	Nut for SK16 High-Speed Collet Chuck
SKN-20B (GH)	Nut for SK20 High-Speed Collet Chuck
SKN-25B (GH)	Nut for SK25 High-Speed Collet Chuck



### Wrench for SK Collet Chuck

Standard Style Part Number	High-Speed Style Part Number	Description
SKL-6W	GH6	Wrench for SK6 Collet Chuck
SKL-10	GH10	Wrench for SK10 Collet Chuck
9HC16	GH16	Wrench for SK16 Collet Chuck
9HC22	GH20	Wrench for SK20 Collet Chuck
9HC22	GH25	Wrench for SK25 Collet Chuck



### Torque Wrench and Attachment for SK Collet Chuck

Part Number	Description
TQW-025	Torque wrench for SK6 Collet Chuck Nut
TQW-150	Torque wrench for SK10/16/20/25 Collet Chuck Nut
TQW-SK06(18)	SK6 attachment for TQW-025 torque wrench
TQW-SK10(1)	SK10 attachment for TQW-150 torque wrench
TQW-SK16(43)	SK16 attachment for TQW-150 torque wrench
TQW-ER32/SK20(50)	SK20 attachment for TQW-150 torque wrench
TQW-SK25(60)	SK25 attachment for TQW-150 torque wrench





## Back Up Screws

### Standard SK Collet Chuck

Figure 1

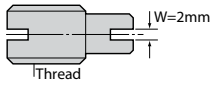
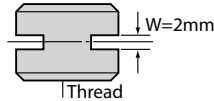

Figure 2



Collet Chuck	Part Number	Thread	Figure
SK6	SKG-8	M8	1
SK10	SKG-12L	M12	1
SK16	SKG-18L	M12/M18 P1.5	1
SK20	SKG-22	M12/M28 P2.0	1
SK25	SKG-28	M12/M28 P2.0	1

#### \*Exceptions

Collet Chuck	Part Number	Thread	Figure
BT30-SK10-45	SKG-12S	M12	2
BT30-SK16-90	SKG-12S	M12/M18 P1.5	2
BT30-SK16-60	SKG-12L	M12/M18 P1.5	1
BT40-SK16-60	SKG-18S	M12/M18 P1.5	2
BT30-SK20-60	SKG-12S	M12/M18 P1.5	2
BT30-SK20-90	SKG-12	M12/M28 P2.0	2
BT30-SK25-90	SKG-12	M12/M28 P2.0	2
BT40-SK25-75			

### Coolant-Thru Back-Up Screw

Collet Chuck	Part Number	Cutter Shank	d	Thread
SK10	SKG-12HA	4mm	ø2.5mm	M12
	SKG-12H	6mm	ø4mm	
SK16	SKG-18HA	5mm	ø3.5mm	M12/M18 P1.5
	SKG-18H	10mm	ø10mm	
SK25	SKG-28H	16mm	ø12mm	M12/M28 P2.0

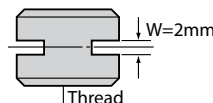

#### \*Exceptions

Collet Chuck	Part Number	Cutter Shank	d	Thread
BT30-SK16-60, -90	SKG-12HA	4mm	ø2.5mm	M12/M18 P1.5
	SKG-12H	6mm	ø4mm	
BT30-SK25-90	SKG-12HA	4mm	ø2.5mm	M12/M28 P2.0
BT40-SK25-75	SKG-12H	6mm	ø4mm	M12/M28 P2.0

### DIN and Coolant-Thru SK Collet Chuck

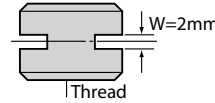

Collet Chuck	Part Number	Cutter Shank	Thread
SK6-...C, ...F	SKG6-6HG	4mm	M8
SK10-...C, ...F	SKG10-10HGA	4mm	M12
	SKG10-10HG	6mm	
SK16-...C, ...F	SKG16-12HGA	5mm	M12/M18 P1.5
	SKG16-12HG	10mm	
SK25-...C, ...F	SKG25-24HG	16mm	M12/M28 P2.0

#### \*Exceptions

Collet Chuck	Part Number	Cutter Shank	Thread
BT40-SK16F-90	SKG16-12HGBA	5mm	M12/M18 P1.5
	SKG16-12GB	10mm	
HSK50A-SK16C-120	SKG16-10HGA	5mm	M12/M18 P1.5
HSK63A-SK16C-120			
HSK100A-SK16C-120			
NC5-46-SK16C-90	SKG16-10HG	10mm	M12/M18 P1.5
NC5-46-SK16C-120			
BT40-SK25F-120	SKG25-24HGA	16mm	M12/M28 P2.0
BT50-SK25F-105			
BT40-SK25F-90	SKG25-18HGC	16mm	M12/M28 P2.0
BT40-SK25C-90	SKG25-18HGD		
NC5-63-SK25C-135	SKG25-18HGE	16mm	M12/M28 P2.0
NC5-85-SK25C-135			
HSK63A-SK25C-135			
HSK100A-SK25C-145	SKG25-18HGE	16mm	M12/M28 P2.0

**ARE YOU GETTING THE MOST OUT OF YOUR  
CNC TURNING CENTER?**



**I.C.E. (Internal Coolant + External Option) Live Tooling**

- I.C.E. Live Tools are designed to be run with or without coolant through the live tool, allowing them to be run dry.
- Can be used in a variety of applications without changing out tooling.
- 3 different coolant setups depending on application: No coolant, coolant through nozzle, coolant through spindle.
- Easy to change between coolant setups allowing for minimal downtime.

Tightening Torque: 70 ft.-lbs. • Collet Size: ER 32 • Pin: 1/2" Solid Carbide

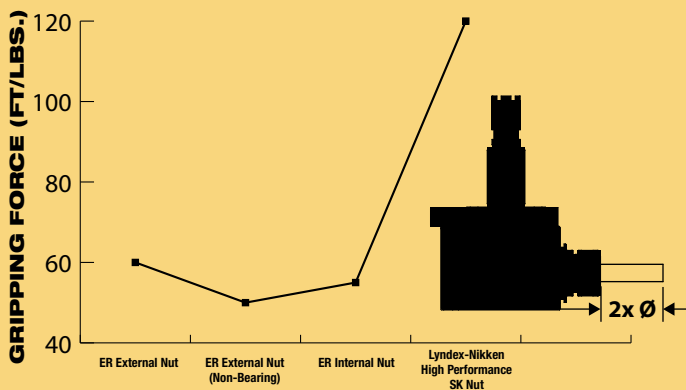

**BENEFITS OF HIGHER GRIPPING FORCE**

- Machine with higher chip load and reduce cycle time
- Reduction in end mill pulling reduces scrapping parts
- Eliminate over tightening that can lead to collet damage and excessive run-out
- Better overall cutting condition

See the **POWER** of SK on YouTube  
@LyndexNikkenMedia or scan the QR codes:  
**SK performance on a lathe & SK performance on a mill**



Phone: (847) 367-4800



Email: sales@lyndexnikken.com



www.lyndexnikken.com

Connect with us on our social media channels!

