

Tap Collets

Torque Control Tap Collets - DIN 371/376 Standard

Standard collets are used for standard and coolant-thru tap holders, maximum 750 PSI.

Part Number	System	Tap Size	Tap Shank Ø	Drive Square ☒
SES1-2.5X2.1	#1	M1.4, M1.8, M3	2.50	2.10
SES1-2.8X2.1	#1	M2, M2.2, M2.5, M4	2.80	2.10
SES1-3.5X2.7	#1	M3, M5	3.50	2.70
SES1-4.0X3.0	#1	M3.5	4.00	3.00
SES1-4.5X3.4	#1	M4, M6	4.50	3.40
SES1-6.0X4.9	#1	M5, M6, M8	6.00	4.90
SES1-7.0X5.5	#1	M10	7.00	5.50
SES1-8.0X6.2	#1	M8, M10	8.00	6.20
SES1-9.0X7.0	#1	M12	9.00	7.00
SES1-10.0X8.0	#1	M10	10.00	8.00
SES1-11.0X9.0	#1	M14	11.00	9.00
SES2-6.0X4.9	#2	M5, M6, M8	6.00	4.90
SES2-7.0X5.5	#2	M10	7.00	5.50
SES2-8.0X6.2	#2	M8, M10	8.00	6.20
SES2-9.0X7.0	#2	M12	9.00	7.00
SES2-10.0X8.0	#2	M10	10.00	8.00
SES2-11.0X9.0	#2	M14	11.00	9.00
SES2-12.0X9.0	#2	M16	12.00	9.00
SES2-14.0X11.0	#2	M18	14.00	11.00
SES2-16.0X12.0	#2	M20	16.00	12.00
SES2-18.0X14.5	#2	M22, M24	18.00	14.50
SES3-8.0X6.2	#2	M8, M10	8.00	6.20
SES3-9.0X7.0	#3	M12	9.00	7.00
SES3-10.0X8.0	#3	M10	10.00	8.00
SES3-11.0X9.0	#3	M14	11.00	9.00
SES3-12.0X9.0	#3	M16	12.00	9.00
SES3-14.0X11.0	#3	M18	14.00	11.00
SES3-16.0X12.0	#3	M20	16.00	12.00
SES3-18.0X14.5	#3	M22, M24	18.00	14.50
SES3-20.0X16.0	#3	M27, M30	20.00	16.00
SES3-22.0X18.0	#3	M30	22.00	18.00
SES3-25.0X20.0	#3	M33, M36	25.00	20.00
SES3-28.0X22.0	#3	M36	28.00	22.00

Note: Dimensions are shown in mm.

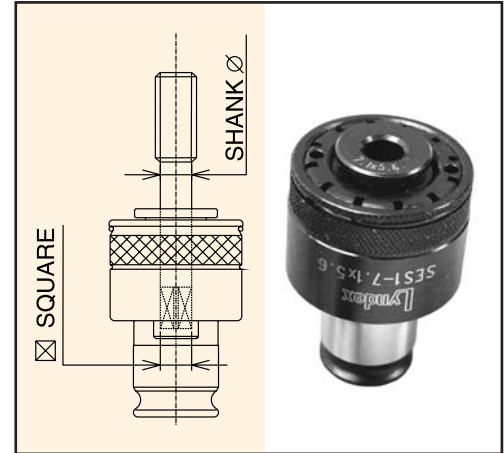

Dimensional Data

Type/System	L	D1	D2
#1	0.98"	1.28"	0.75"
#2	1.34"	1.99"	1.22"
#3	1.77"	2.83"	1.89"

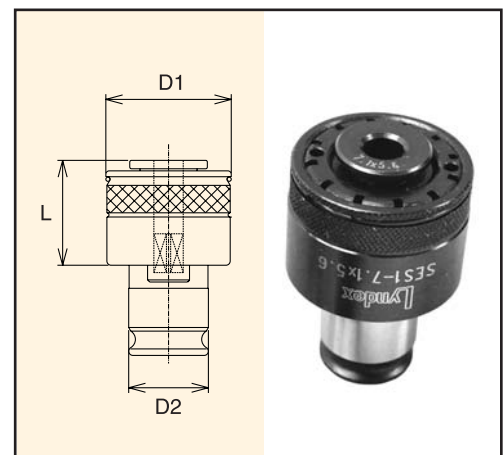

Accessories:



Tap Collets
Pages 106-117



Tap Spanner Wrench
Page 118

End Mill Holders
ERTG/DA Collet Chucks
Shell Mill Holders
Drill Chucks
Tap Holders