

WIRING INSTRUCTIONS

TITLE DOUBLE GEAR REDUCTION MAGNUM (ALUMINUM GEAR CASE)
 MILWAUKEE ELECTRIC TOOL CORP 13135 WEST LISBON RD BROOKFIELD, WIS DATE
 OCT. '80

BULLETIN
 58-01-0072

NOTE:
 FOR DOUBLE INSULATED TOOLS
 DISREGARD WIRE NO. 3

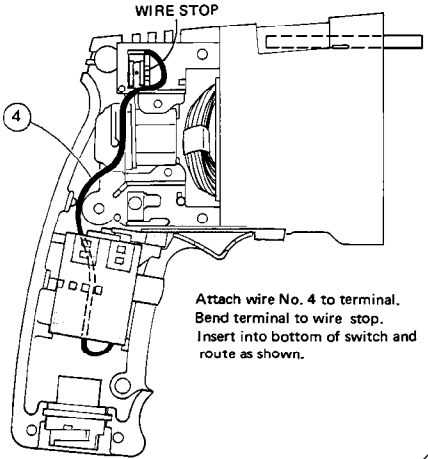

STEP ONE

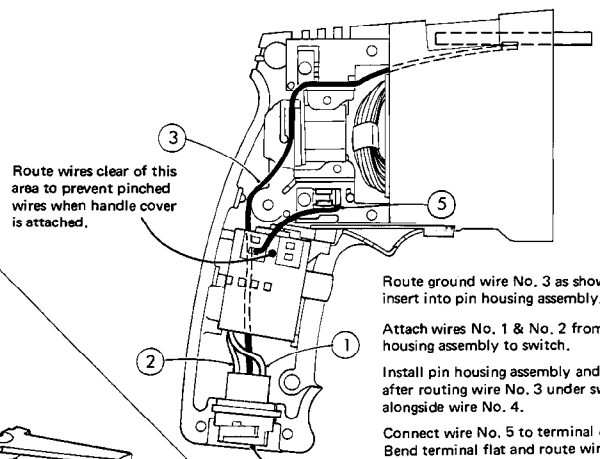

STEP TWO

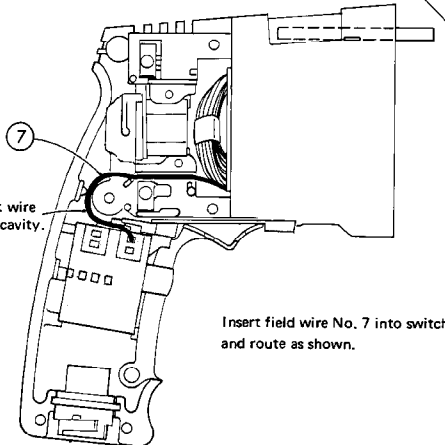
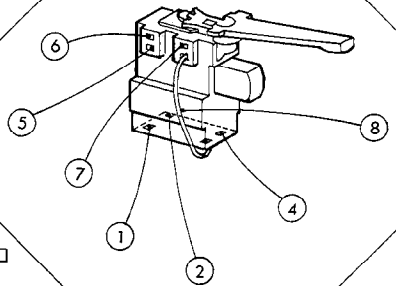

STEP THREE

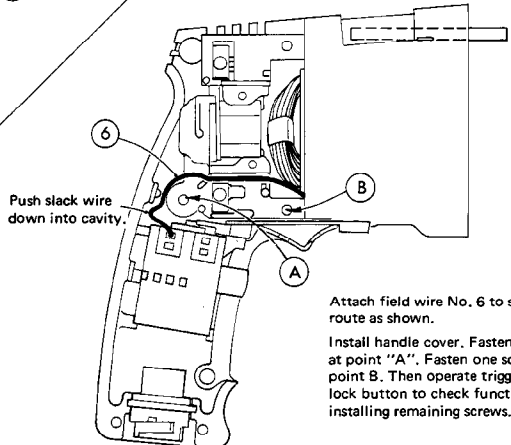

STEP FOUR

WIRING SPECIFICATIONS

Wire No.	Wire Color	Origin or Gauge	Length	Terminals, Connectors and 1 or 2 End Wire Preparation.
1	White	*	—	Component of Pin Housing Assy. *
2	White	*	—	Component of Pin Housing Assy. *
3	Green	*	—	Component of Motor Housing Assy. *
4	Black	*	—	Complete Lead Assembly *
5	Black	*	—	Complete Lead Assembly *
6	Blue	Field	4"	Strip 3/8" & Tin
7	White	Field	4"	Strip 3/8" & Tin
8	—	—	—	Supplied with Switch
				*Refer to Service Parts List

NOTE:
 All leads must be held to $\pm 1/8"$.
 All field leads to be measured from and perpendicular to laminations.
 All lead lengths are before stripping.

TERMINAL DESCRIPTION		
Code	Part No.	Qty.
CONNECTOR DESCRIPTION		
Code	Part No.	Qty.