



# SERVICE PARTS LIST

**BULLETIN NO.**  
**54-38-2680**

<b>SPECIFY CATALOG NO. AND SERIAL NO. WHEN ORDERING PARTS</b>		REVISED BULLETIN	DATE
<b>CORDLESS 18 VOLT 4-1/2" CUT-OFF/GRINDER</b>			Jan. 2009
<b>CATALOG NO.</b>	<b>2680-20</b>	<b>STARTING SERIAL NO.</b>	<b>B96A</b>
			<b>WIRING INSTRUCTION</b> <b>SEE REVERSE SIDE</b>

**EXAMPLE:**  
Component Parts (Small #) Are Included When Ordering The Assembly (Large #).

**FIG. LUBRICATION:**  
(Use Type 'Y' grease, No. 49-08-5270)

- 10 Apply a thin coat of grease to the Spindle Hub O-Ring.
- 13,38 Apply grease to all teeth of the Pinion and Gear.
- 27 Place 1/8 oz. grease in Gearcase cavity.
- 32,33 Apply a thin coat of grease between Spindle Lock Shaft and O-Ring.

Functionally check the Spindle Lock mechanism. Spindle Lock must return briskly when released from engagement in Gear (13).

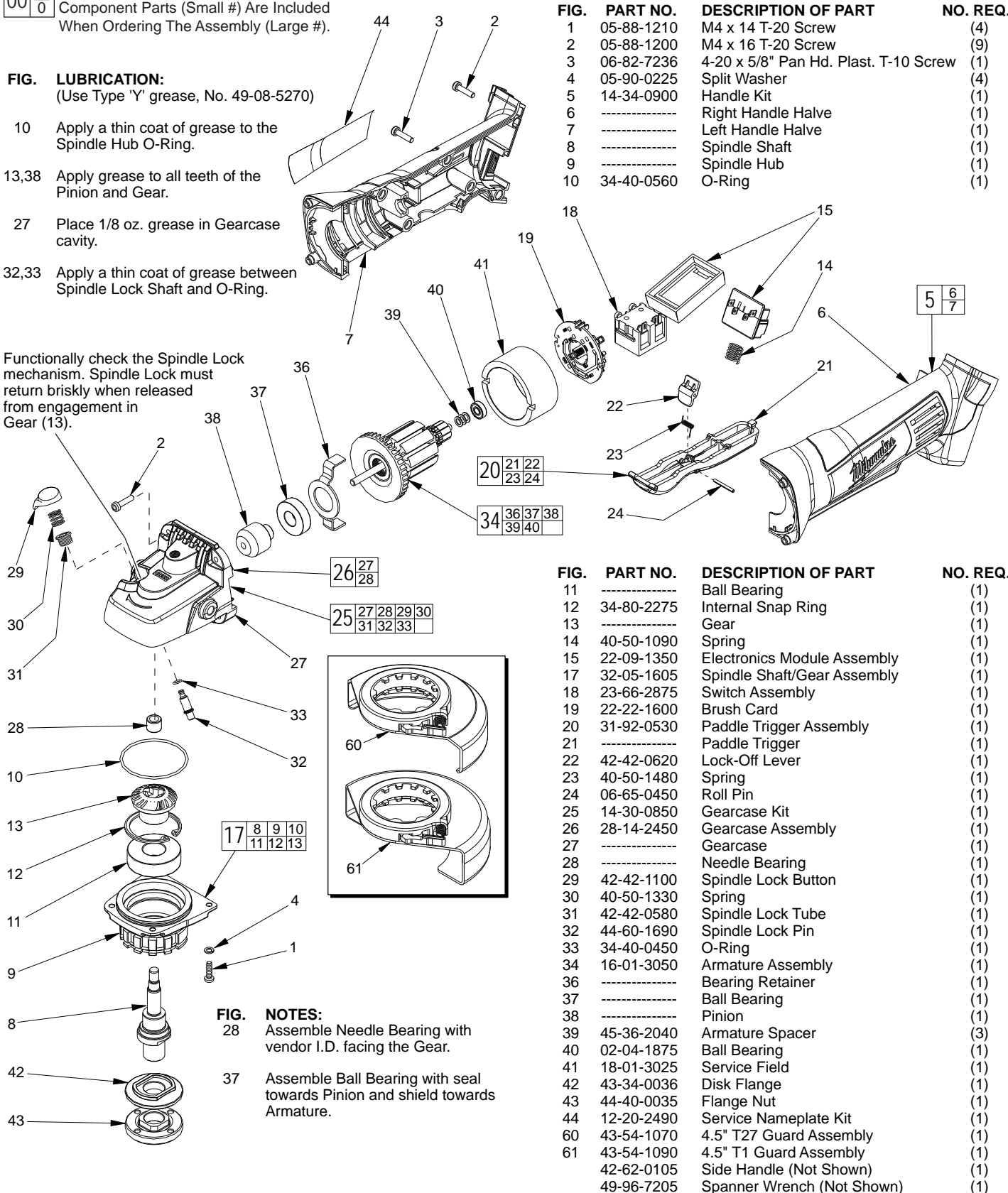
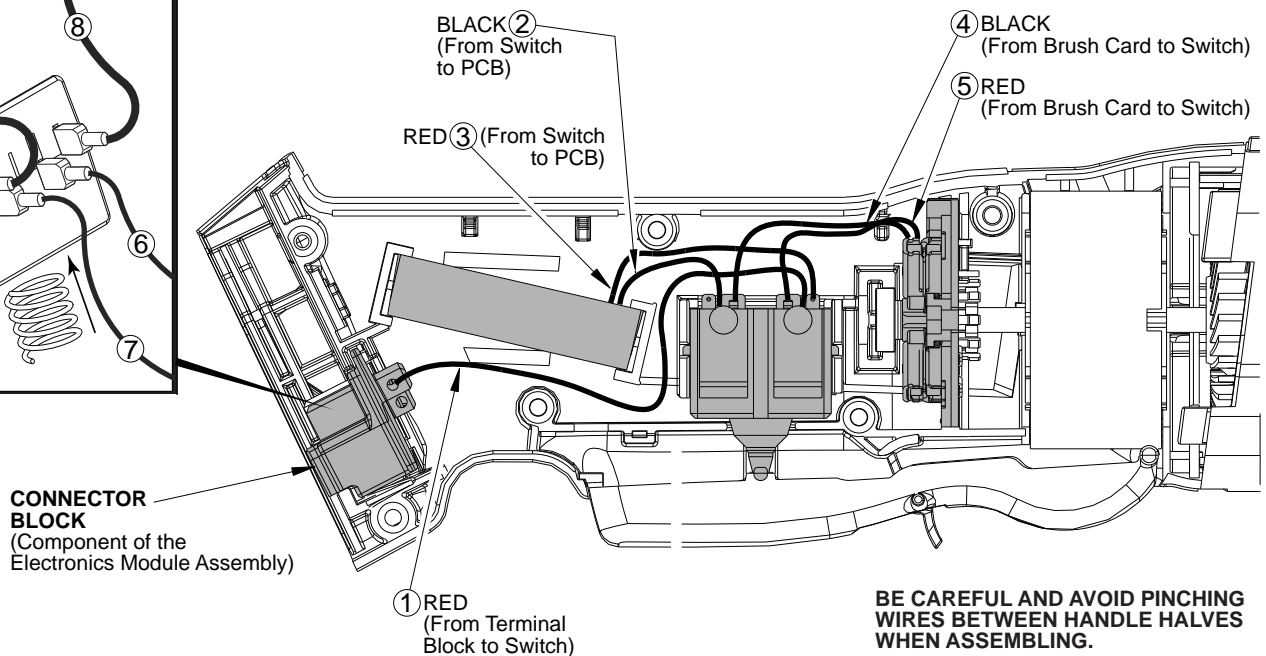
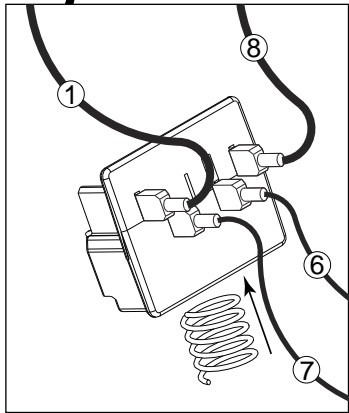
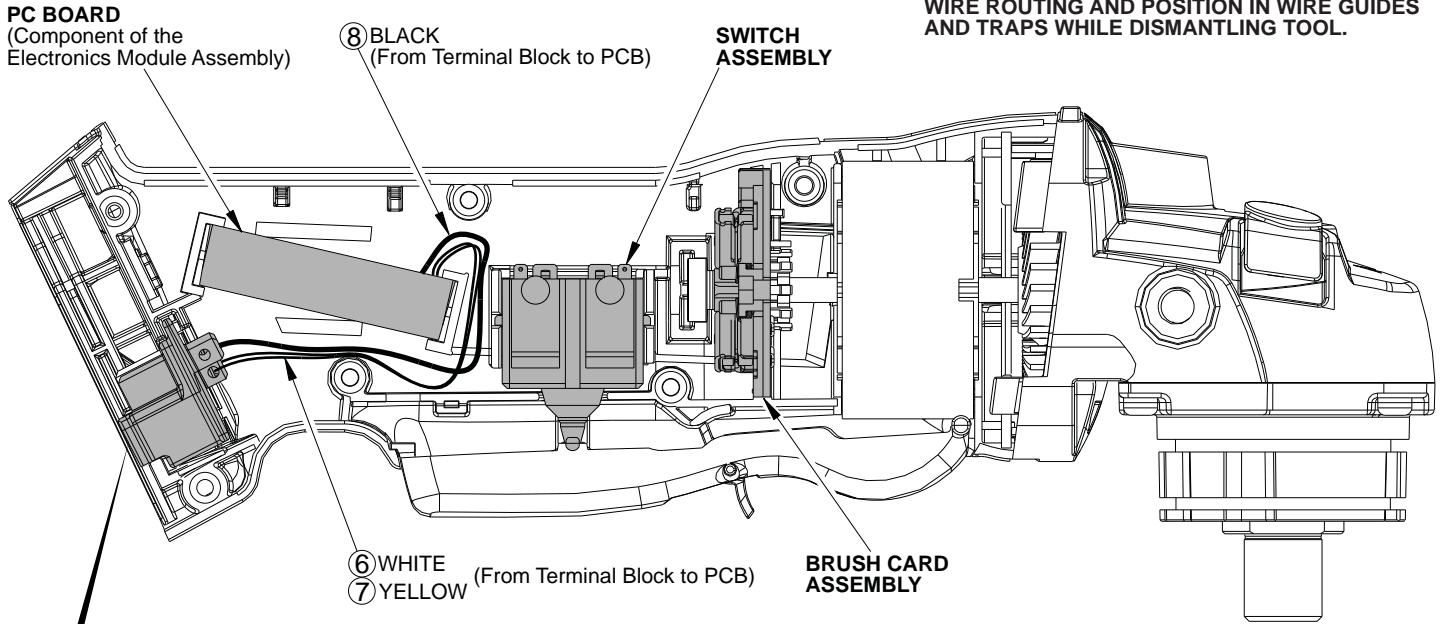

FIG.	PART NO.	DESCRIPTION OF PART	NO. REQ.
1	05-88-1210	M4 x 14 T-20 Screw	(4)
2	05-88-1200	M4 x 16 T-20 Screw	(9)
3	06-82-7236	4-20 x 5/8" Pan Hd. Plast. T-10 Screw	(1)
4	05-90-0225	Split Washer	(4)
5	14-34-0900	Handle Kit	(1)
6	-----	Right Handle Halve	(1)
7	-----	Left Handle Halve	(1)
8	-----	Spindle Shaft	(1)
9	-----	Spindle Hub	(1)
10	34-40-0560	O-Ring	(1)

FIG.	PART NO.	DESCRIPTION OF PART	NO. REQ.
11	-----	Ball Bearing	(1)
12	34-80-2275	Internal Snap Ring	(1)
13	-----	Gear	(1)
14	40-50-1090	Spring	(1)
15	22-09-1350	Electronics Module Assembly	(1)
17	32-05-1605	Spindle Shaft/Gear Assembly	(1)
18	23-66-2875	Switch Assembly	(1)
19	22-22-1600	Brush Card	(1)
20	31-92-0530	Paddle Trigger Assembly	(1)
21	-----	Paddle Trigger	(1)
22	42-42-0620	Lock-Off Lever	(1)
23	40-50-1480	Spring	(1)
24	06-65-0450	Roll Pin	(1)
25	14-30-0850	Gearcase Kit	(1)
26	28-14-2450	Gearcase Assembly	(1)
27	-----	Gearcase	(1)
28	-----	Needle Bearing	(1)
29	42-42-1100	Spindle Lock Button	(1)
30	40-50-1330	Spring	(1)
31	42-42-0580	Spindle Lock Tube	(1)
32	44-60-1690	Spindle Lock Pin	(1)
33	34-40-0450	O-Ring	(1)
34	16-01-3050	Armature Assembly	(1)
36	-----	Bearing Retainer	(1)
37	-----	Ball Bearing	(1)
38	-----	Pinion	(1)
39	45-36-2040	Armature Spacer	(3)
40	02-04-1875	Ball Bearing	(1)
41	18-01-3025	Service Field	(1)
42	43-34-0036	Disk Flange	(1)
43	44-40-0035	Flange Nut	(1)
44	12-20-2490	Service Nameplate Kit	(1)
60	43-54-1070	4.5" T27 Guard Assembly	(1)
61	43-54-1090	4.5" T1 Guard Assembly	(1)
	42-62-0105	Side Handle (Not Shown)	(1)
	49-96-7205	Spanner Wrench (Not Shown)	(1)

**FIG. NOTES:**  
28 Assemble Needle Bearing with vendor I.D. facing the Gear.  
37 Assemble Ball Bearing with seal towards Pinion and shield towards Armature.

AS AN AID TO REASSEMBLY, TAKE NOTICE OF WIRE ROUTING AND POSITION IN WIRE GUIDES AND TRAPS WHILE DISMANTLING TOOL.



BE CAREFUL AND AVOID PINCHING WIRES BETWEEN HANDLE HALVES WHEN ASSEMBLING.

**WIRING SPECIFICATIONS**

Wire No.	Wire Color	Origin or Gauge	Length	Terminals, Connectors and 1 or 2 End Wire Preparation
1	Red	14	-----	Component of the Electronics Module Assembly.
2	Black	14	-----	Component of the Electronics Module Assembly.
3	Red	18	-----	Component of the Electronics Module Assembly.
4	Black	15	-----	Component of the Brush Card Assembly.
5	Red	15	-----	Component of the Brush Card Assembly.
6	White	24	-----	Component of the Electronics Module Assembly.
7	Yellow	24	-----	Component of the Electronics Module Assembly.
8	Black	14	-----	Component of the Electronics Module Assembly.

**ATTENTION**  
OBSERVE PRECAUTIONS FOR HANDLING ELECTROSTATIC SENSITIVE DEVICES