



SERVICE PARTS LIST

BULLETIN NO.
54-26-2755

SPECIFY CATALOG NO. AND SERIAL NO. WHEN ORDERING PARTS		REVISED BULLETIN	DATE
M18™ FUEL™ 1/4" Hex Impact Driver (Baseline)			June 2015
CATALOG NO.	2753-20	STARTING SERIAL NO.	G76A
		WIRING INSTRUCTION SEE PAGE 2	

EXAMPLE:
00 0 Component Parts (Small #) Are Included
When Ordering The Assembly (Large #).

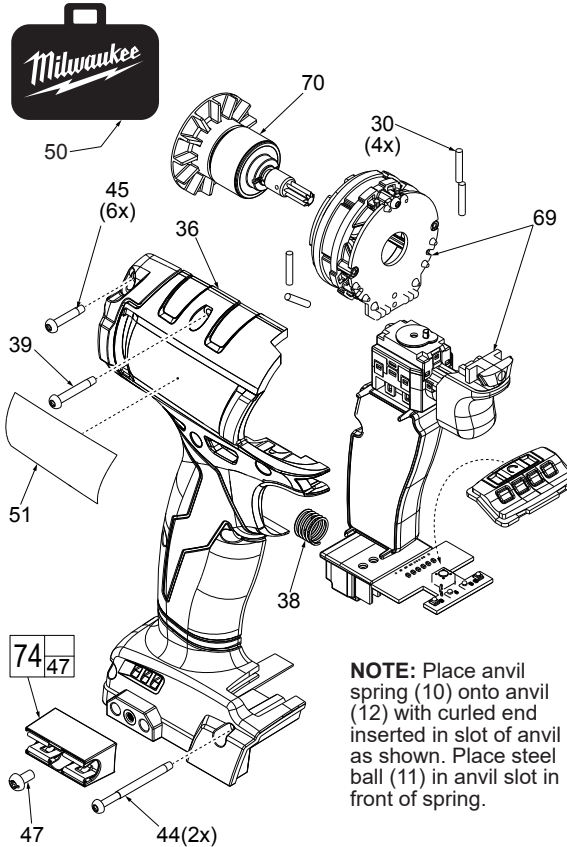

NOTE: Place anvil spring (10) onto anvil (12) with curled end inserted in slot of anvil as shown. Place steel ball (11) in anvil slot in front of spring.

IMPORTANT NOTE: Gearcase end cap #68 is LEFT HAND THREAD!

As an aid to assembly, carefully lower the complete front end of tool (gearcase / impacting system) onto the gearcase end cap. Gently hand tighten front end assembly onto gearcase end cap. Be careful not to cross-thread! Once installed by hand, seat gearcase end cap with a good adjustable wrench using light pressure. Do not over tighten!

LEFT HAND THREAD

NOTE: Components of the Impacting Assembly (67) can drop out of the gearcase (6). Care must be taken to hold these elements in place when assembling onto the gearcase end cap (68).

FIG.	PART NO.	DESCRIPTION OF PART	NO. REQ.
1	31-12-0017	Rubber Cap	(1)
2	42-76-0019	Sleeve	(1)
3	34-60-0725	Retaining Ring	(1)
4	45-88-2025	Washer	(1)
5	40-50-1470	Spring	(1)
6	28-50-0013	Gearcase with Bushing	(1)
9	45-88-2653	Plastic Washer	(1)
10	40-50-0057	Anvil Spring	(1)
11	02-02-0170	3.5mm Steel Ball	(1)
12	42-06-0017	1/4" Hex Anvil	(1)
13	02-02-1300	5mm Steel Ball	(1)
18	02-02-0180	3/16" Steel Ball	(2)
24	-----	Ring Gear	(1)
30	45-30-0022	Rubber Slug	(4)
36	-----	Right Handle Halve	(1)
37	-----	Left Handle Halve	(1)
38	40-50-1090	Compression Spring	(1)
39	06-82-7336	M3 x 20mm Pan Hd. ST T-10 Screw	(1)
40	45-24-0013	Forward/Reverse Shuttle	(1)
44	06-82-0013	M3 x 38mm Pan Hd. ST T-10 Tamproof	(2)
45	06-82-7236	M3 x 16mm Pan Hd. ST T-10 Tamproof	(6)
47	06-82-0130	6-32 x 5/16" Pan Hd. T-15 Machine Scr.	(2)
50	42-55-2753	Blow Molded Carrying Case	(1)
51	12-20-0068	Service Nameplate	(1)
65	14-30-0012	Gearcase Assembly	(1)
67	14-46-0014	Impacting Assembly	(1)
68	44-66-0023	Gearcase End Cap with Ball Bearing	(1)
69	14-20-0013	Electronics Assembly	(1)
		Consisting of: On-Off Switch, PCBA, Stator, LED, HV Protection and Battery Connector Block	(1)

FIG.	PART NO.	DESCRIPTION OF PART	NO. REQ.
70	16-07-0012	Rotor Assembly	(1)
71	31-44-0023	Housing Halve Assembly	(1)
72	45-24-0017	Speed Selector Assembly	(1)
73	42-70-0059	Belt Clip Assembly	(1)
74	43-72-0046	Bit Holder Assembly	(1)
81	49-12-0011	Rubber Boot (Optional, Accessory)	(1)

- FIG. LUBRICATION (Type 'J' Grease, No. 49-08-4220):**
- 11, 12 Lightly coat front washer surface of anvil (12) with grease, place a dab in the ball slot of anvil and in needle bearing inside the anvil.
 - 24, 67 Lightly coat the I.D. of the ring gear (24) and the center of the planet gears of impacting assembly with grease.
 - 6 Coat inside of bushing inside front gearcase with grease.
 - 70 Coat pinion of rotor assembly (70) with grease.

Rotor Assembly

Stator Assembly with Hall PCBA

Watch for pinched wires here. Tuck leads down in cavity behind switch.

Battery Connector Block Assembly

Compression Spring

High Voltage Protection Wire. Place terminal over screw boss and route down in cavity behind forward/reverse shuttle.

Route LED wires down in cavity behind forward/reverse shuttle.

LED Assembly

On-Off Switch

Main PCBA

Speed PCBA

Speed Selector Assembly

