



Digimatic Indicators



Dial Indicators



Dial Test Indicators



Dial Indicator Applications and Stands



ID-H



ID-C



2046S



2109S-10



ID-N / ID-B



Caliper gage

INDEX

Digimatic Indicators		
ABSOLUTE Digimatic Indicator ID-S		F-2
ABSOLUTE Digimatic Indicator ID-U		F-3
ABSOLUTE Digimatic Indicator ID-C		F-4
ABSOLUTE Digimatic Indicator ID-H		F-10
ABSOLUTE Digimatic Indicator ID-F		F-11
ABSOLUTE Digimatic Indicator ID-N/B		F-12
EC Counter		F-13
Dial Indicators		
Dial Indicators		F-14
Special Dial Indicators		F-24
Dial Indicator (One Revolution Type)		F-26
Dial Indicator (Long Stroke Type)		F-28
Dial Indicator (Large Dial Face and Long Stroke Type)		F-30
ANSI/AGD Type Metric Dial Indicator		F-32
Hicator, Signal Hicator		F-33
Back Plunger Type Dial Indicator		F-34
Contact Points		F-36
Interchangeable Backs		F-40
Spindle Lifting Lever and Cable		F-41
Color-coded Spindle Caps		F-42
Limit Stickers		F-42
Dial Indicator Repair Tool Kit		F-43
Dial Indicator Crystal Setter		F-43
Dial Test Indicators		
Dial Test Indicator		F-44
Pocket Type Dial Test Indicator		F-50
Styli, Stems and Holders		F-52
Dial Indicator Applications		
i-Checker		F-54
UDT-2 Dial Gage Tester		F-55
Calibration Tester		F-55
Thickness Gages		F-56
Light-Weight Dial Thickness Gage		F-58
Pocket Thickness Gage		F-58
Digimatic Caliper Gage		F-59
Dial Caliper Gage		F-60
Bench Gage		F-62
Upright Gage		F-63
Dial Snap Gage		F-64
Female Screw Thread Comparator		F-65
Roll Caliper		F-65
Contact Force Gage		F-66
V-Block Set		F-66
Stands		
Magnetic Stand		F-67
Dial Gage Stand		F-68
Transfer Stand		F-69
Granite Comparator Stands		F-70
Comparator Stands		F-71
Heavy Duty Comparator Stand		F-72

ABSOLUTE Digimatic Indicator ID-S

SERIES 543 — with Economical Design

FEATURES

- As compact as standard Series 2 dial indicators.
- The ID-S indicates the absolute position of the spindle from the origin point at power-on, allowing measurement to start immediately.
- Zero-setting is performed with the ORIGIN button, and this setting does not have to be repeated during the entire life of the battery, even after power-off.
- Measurement error due to spindle over-speed is eliminated with the ABSOLUTE Encoder.
- SPC data output.



543-690



SPECIFICATIONS

Metric		ISO/JIS type		ANSI/AGD type		
Resolution	Order No. (w/ lug, flat-back)	Range	Accuracy	Measuring force	Remarks	
0.001mm	543-690	543-690B	12.7mm	0.003mm	2.0N or less	—
0.001mm	543-694	543-694B	12.7mm	0.003mm	2.5N or less	Dust-proof (IP53)
0.01mm	543-681	543-681B	12.7mm	0.02mm	2.0N or less	—

Inch/Metric		ISO/JIS type		ANSI/AGD type		
Resolution	Order No. (w/ lug, flat-back)	Range	Accuracy	Measuring force	Remarks	
.00005"/0.001mm	543-691	543-691B	.5"	.00012"	2.0N or less	—
.00005"/0.001mm	543-695	543-695B	.5"	.00012"	2.5N or less	Dust-proof (IP53)
.00005"/0.001mm	543-692	543-692B	.5"	.00012"	2.0N or less	—
.00005"/0.001mm	543-696	543-696B	.5"	.00012"	2.5N or less	Dust-proof (IP53)
.0001"/0.001mm	543-693	543-693B	.5"	.00012"	2.0N or less	—
.0005"/0.01mm	543-682	543-682B	.5"	.0008"	2.0N or less	—
.0005"/0.01mm	543-683	543-683B	.5"	.0008"	2.0N or less	—

DIMENSIONS

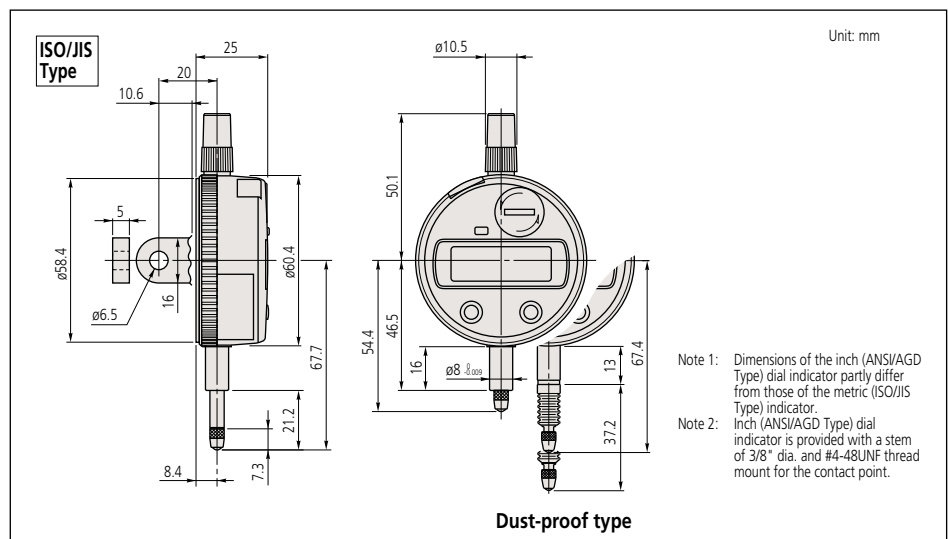

(Refer to page IX for details.)

Technical Data

Accuracy: Refer to the list of specifications (excluding quantizing error)
 Resolution: 0.01mm, 0.001mm, .0005"/0.01mm, .0001"/0.001mm or .00005"/0.001mm
 Display: LCD Character Height 8.5mm
 Scale type: ABSOLUTE electrostatic linear encoder
 Max. response speed: Unlimited
 Measuring force: Refer to the list of specifications
 Stem dia.: 8mm (ISO/JIS type) or 3/8" (ANSI/AGD type)
 Contact point: Carbide ball with M2.5x0.45 (ISO/JIS type) Carbide ball with #4-48UNF (ANSI/AGD type)
 Battery: SR44 (1 pc.), **938882**
 Battery life: Approx. 20,000 hours under normal use
 Dust/Water protection level: IP42 (IP53: **543-694, 543-695, 543-696**)

Function

Origin-set, (Zeroset), Counting direction switching, Power ON/OFF, Data output, inch/mm conversion (inch/mm models)
 Alarm: Low voltage, Counting value composition error

Optional Accessories

- 905338:** SPC cable (1m)
- 905409:** SPC cable (2m)
- 02AZD790F:** SPC cable for U-WAVE(160mm)
- 903424:** Spindle lifting lever (ISO/JIS type)
- 903425:** Spindle lifting lever (ANSI/AGD type)
- 540774:** Spindle lifting cable
- 02ACA376:** Spare rubber boot (for dust-proof type)
- 02ACB610:** Back with post
- 02ACB630:** Adjustable back
- 02ACB640:** Back with offset lug
- 02ACB650:** Magnetic back
- 02ACB670:** Back with screw mount
- 02ACB680:** Back with adjustable bracket
- : Contact points (See page F-36.)



Absolute System Patented by MITUTOYO

(Refer to page IX for details.)

Technical Data

Accuracy: Refer to the list of specifications (excluding quantizing error)
 Resolution: 0.01mm or .0005"/0.01mm,
 Display: LCD Character Height 8mm
 Scale type: ABSOLUTE electrostatic linear encoder
 Max. response speed: Unlimited
 Measuring force: Refer to the list of specifications
 Stem dia.: 8mm (ISO/JIS type) or 3/8" (ANSI/AGD type)
 Contact point: Carbide ball with M2.5x0.45 (ISO/JIS type)
 Carbide ball with #4-48UNF (ANSI/AGD type)
 Battery: SR44 (1 pc.), **938882**
 Battery life: Approx. 20,000 hours under normal use
 Dust/Water protection level: IP42

Function

Origin-set, (Zeraset), Counting direction switching, Power ON/OFF, Data output, inch/mm conversion (inch/mm models)
 Alarm: Low voltage, Counting value composition error

Optional Accessories

905338: SPC cable (1m)
905409: SPC cable (2m)
02AZD790F: SPC cable for U-WAVE(160mm)
540774: Spindle lifting cable (stroke: 10mm)
 ———: Contact points (See page F-36.)

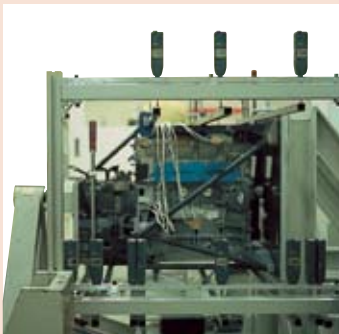

Application example

ABSOLUTE Digimatic Indicator ID-U

SERIES 575 — Slim and Economical Design

FEATURES

- Slim type digital indicator with a low price.
- Large LCD and simple key operation.
- The ID-U displays the absolute position of the spindle from the origin point at power-on.
- Zero-setting is performed with the ORIGIN button, and this setting does not have to be repeated for the entire life of the battery, even after power-off.
- Ideal for installation into measuring devices because of its compact design and long battery life.
- The ABSOLUTE Encoder eliminates spindle over-speed error and prevents electrical noise interference errors.
- SPC data output.



575-121



SPECIFICATIONS

Metric		ISO/JIS type		ANSI/AGD type		
Resolution	Order No. (w/ lug, flat-back)	Range	Accuracy	Measuring force	Remarks	
0.01mm	—	575-121	25.4mm	0.02mm	1.8N or less	—

Inch/Metric		ISO/JIS type		ANSI/AGD type		
Resolution	Order No. (w/ lug, flat-back)	Range	Accuracy	Measuring force	Remarks	
.0005"/0.01mm	—	575-122	1"	.0008"	1.8N or less	—
.0005"/0.01mm	—	575-123	1"	.0008"	1.8N or less	—

DIMENSIONS

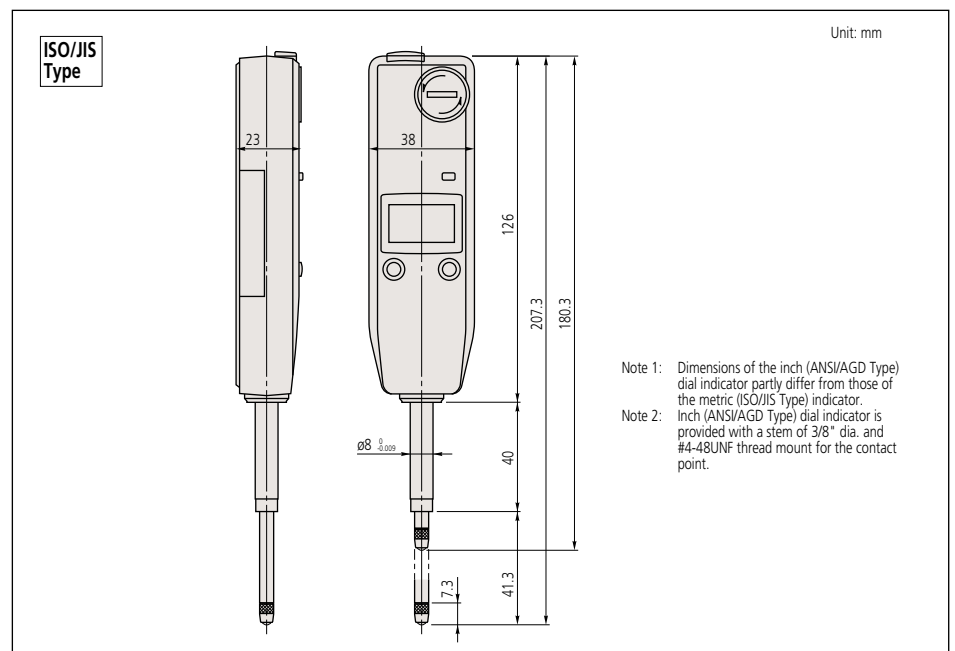

ABSOLUTE Digimatic Indicator ID-C

SERIES 543 — Standard Type

FEATURES

- As compact as standard Series 2 dial indicators.
- Large, easy-to-read LCD.
- SET key: Allows the display to be Zero-Set at any spindle position for comparison measurements. This switch will also allow return to the absolute coordinate and display of the true position from the origin point.
- GO/±NG judgment can be performed by setting upper and lower tolerance limits. The judgment result (GO/±NG) can be displayed in full-size characters.
- Simple calculation by a user-definable factor using the formula Ax ('x' is spindle displacement) can be performed.
- The measuring direction can be reversed.
- Unlimited response speed eliminates spindle over-speed errors.
- The indicator face can be rotated 330° to an appropriate angle for easy reading.
- SPC data output.



Large LCD

The large LCD incorporates 11mm characters giving 1.5 times the character area of existing products (which display 8.5mm characters) making measurement values much easier to read.



Actual size



(Refer to page IX for details.)



(Refer to page IX for details.)

Technical Data

- Accuracy: Refer to the list of specifications (excluding quantizing error)
- Resolution:
- | | |
|----------------------|--------------------------------------|
| 0.01mm type | 0.01mm |
| 0.001mm type | 0.01mm/0.001mm |
| .0005"/0.01mm type | .0005"/0.01mm |
| .00005"/0.001mm type | .0005"/.0001"/.00005"/0.01mm/0.001mm |
- Display: LCD
- Scale type: ABSOLUTE electrostatic linear encoder
- Max. response speed: Unlimited
- Measuring force: Refer to the list of specifications
- Stem dia.: 8mm (ISO/JIS type) or 3/8" (ANSI/AGD type)
- Contact point: Carbide ball with M2.5x0.45 (ISO/JIS type)
Carbide ball with #4-48UNF (ANSI/AGD type)
- Battery: SR44 (1 pc.), **938882**
- Battery life: Approx. 7,000 hours under normal use
- Dust/Water protection level: IP42

Function

- Origin-set/Preset, Zeroset, GO/±NG judgment, Counting direction switching, Power ON/OFF, Simplified calculation, Function lock, Data hold, Data output, inch/mm conversion (inch/mm models)
- Alarm: Low voltage, Counting value composition error, Overflow error, Tolerance limit setting error

Optional Accessories

- 905338:** SPC cable (1m)
- 905409:** SPC cable (2m)
- 02AZD790F:** SPC cable for U-WAVE (160mm)
- 21EZA198:** Spindle lifting lever (12.7mm/.5" ISO/JIS type)
- 21EZA199:** Spindle lifting lever (12.7mm/.5" ANSI/AGD type)
- 21EZA105:** Spindle lifting knob (12.7mm/.5" ISO/JIS type)*
- 21EZA150:** Spindle lifting knob (12.7mm/.5" ANSI/AGD type)*
- 21EZA197:** Spindle lifting knob (25.4mm/1")
- 21EZA200:** Spindle lifting knob (50.8mm/2" models)
- 540774:** Spindle lifting cable 12.7mm and 25.4mm
- 02ACA571:** Auxiliary spindle spring (25.4mm/1" models)**
- 02ACA773:** Auxiliary spindle spring (50.8mm/2" models)**
- Backs (See page F-40.)
- 101039:** Lug-on-center back (25.4mm/1" and 50.8mm/2", ISO/JIS type)
- 101306:** Lug-on-center back (25.4mm/1" and 50.8mm/2", ANSI/AGD type)
- Contact points (See page F-36.)

*Not available for low measuring force models.
**Required when orienting the indicator upside down.

Three large buttons

The popular three-large-button design, which is used in products such as the ABS coolant proof Digimatic indicator ID-N/ID-B, makes buttons easier to press and operations easier to perform.

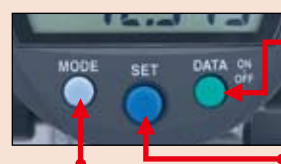

- Power switch
- Data output (when connected to an external device)
- Data hold (when no external device is connected)
- Switches between the ABS (preset) and INC (zeroset) measurement modes
- Parameter setting mode
Measuring direction switching, tolerance judgment setting, resolution switching, scale factor setting, and function lock setting
- inch/mm conversion function

330° rotary display

The display can be rotated 330°, allowing use at a position where you can easily read the measurement value.

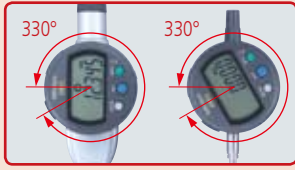

Calculation: f(x) = Ax

Mounting the ID-C on a measuring jig and setting the multiplying factor 'A' (to any value) allows direct measurement without using a conversion table and improves measurement efficiency.

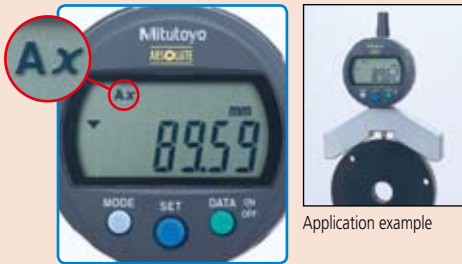

Application example

Function locking

Ensures reliability of measurement by locking the settings to prevent preset function settings from being changed by mistake.



Setting measuring force on low measuring force models

•543-404/404B/405/405B/406/406B

Spindle orientation	Spring	Weight (approximately 0.1N)	Maximum measuring force
Pointing vertically downward	Yes	Yes	0.5N
	Yes	No	0.4N
	No	Yes	0.3N
	No	No	0.2N
Horizontal	Yes	No	0.2N

Note) Operation using configurations other than shown above is not guaranteed.

•543-394/394B/395/395B/396/396B

Spindle orientation	Spring	Weight (approximately 0.1N)	Maximum measuring force
Pointing vertically downward	Yes	Yes	0.7N
	Yes	No	0.6N
	No	Yes	0.4N
	No	No	Not guaranteed
Horizontal	Not guaranteed		

Note) Operation using configurations other than shown above is not guaranteed.

SPECIFICATIONS

Metric	ISO/JIS type		ANSI/AGD type			
Resolution*	Order No. (w/ lug, flat-back)	Range	Accuracy	Measuring force	Remarks	
0.001mm	543-390	543-390B	12.7mm	0.003mm	1.5N or less	—
0.001mm	543-394	543-394B	12.7mm	0.003mm	0.4N - 0.7N	Low measuring force
0.001mm	—	543-470B	25.4mm	0.003mm	1.8N or less	—
0.001mm	—	543-490B	50.8mm	0.005mm	2.3N or less	—
0.01mm	543-400	543-400B	12.7mm	0.02mm	0.9N or less	—
0.01mm	543-404	543-404B	12.7mm	0.02mm	0.2N - 0.5N	Low measuring force
0.01mm	—	543-474B	25.4mm	0.02mm	1.8N or less	—
0.01mm	—	543-494B	50.8mm	0.04mm	2.3N or less	—

Hysteresis: 0.001mm/0.01mm Resolution Type: 0.002mm
0.01mm Resolution Type: 0.02mm

Repeatability: 0.001mm/0.01mm Resolution Type: 0.002mm
0.01mm Resolution Type: 0.02mm

Inch/Metric	ISO/JIS type		ANSI/AGD type			
Resolution*	Order No. (w/ lug, flat-back)	Range	Accuracy	Measuring force	Remarks	
.00005"/0.001mm	543-391	543-391B	.5"	.0001"	1.5N or less	—
.00005"/0.001mm	543-392	543-392B	.5"	.0001"	1.5N or less	—
.00005"/0.001mm	543-395	543-395B	.5"	.0001"	0.4N - 0.7N	Low measuring force
.00005"/0.001mm	543-396	543-396B	.5"	.0001"	0.4N - 0.7N	Low measuring force
.00005"/0.001mm	—	543-471B	1"	.0001"	1.8N or less	—
.00005"/0.001mm	—	543-472B	1"	.0001"	1.8N or less	—
.00005"/0.001mm	—	543-491B	2"	.0002"	2.3N or less	—
.00005"/0.001mm	—	543-492B	2"	.0002"	2.3N or less	—
.0005"/0.01mm	543-401	543-401B	.5"	.001"	0.9N or less	—
.0005"/0.01mm	543-402	543-402B	.5"	.001"	0.9N or less	—
.0005"/0.01mm	543-405	543-405B	.5"	.001"	0.2N - 0.5N	Low measuring force
.0005"/0.01mm	543-406	543-406B	.5"	.001"	0.2N - 0.5N	Low measuring force
.0005"/0.01mm	—	543-475B	1"	.001"	1.8N or less	—
.0005"/0.01mm	—	543-476B	1"	.001"	1.8N or less	—
.0005"/0.01mm	—	543-495B	2"	.0015"	2.3N or less	—
.0005"/0.01mm	—	543-496B	2"	.0015"	2.3N or less	—

Hysteresis: .0005"/.0001"/.0005"/0.001mm/0.01mm Resolution Type: .00010"/0.002mm
.0005"/0.01mm Resolution Type: .0010"/0.02mm

Repeatability: .0005"/.0001"/.0005"/0.001mm/0.01mm Resolution Type: .00010"/0.002mm
.0005"/0.01mm Resolution Type: .0005"/0.02mm

DIMENSIONS

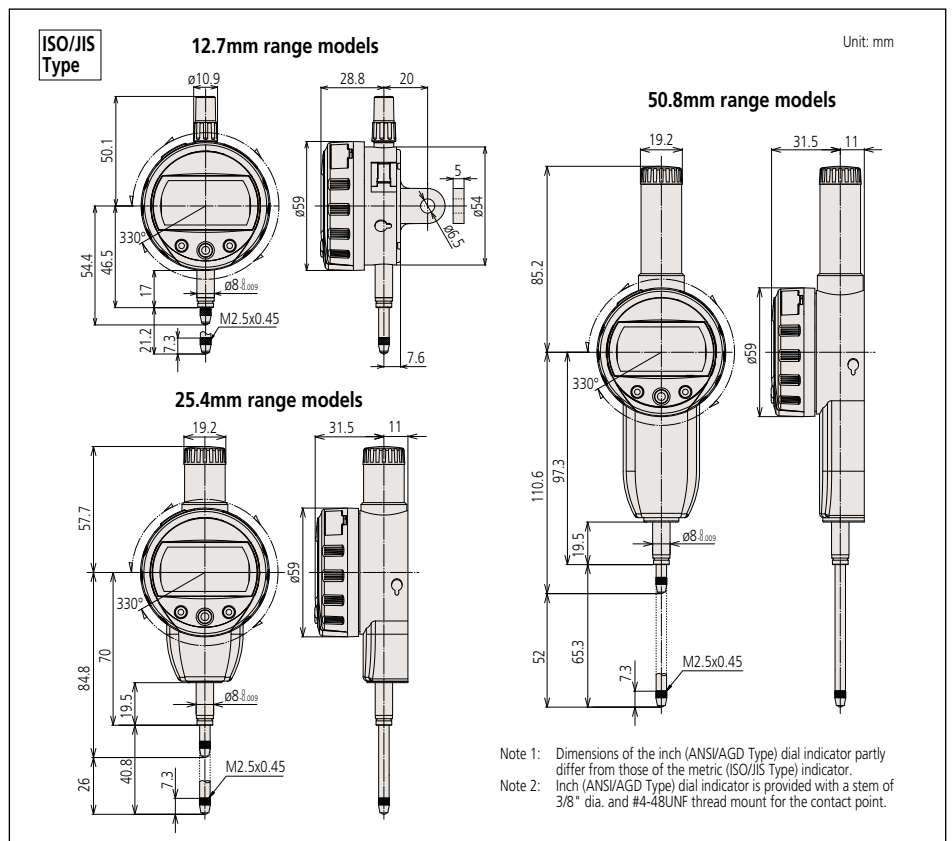

ABSOLUTE Digimatic Indicator ID-C

SERIES 543 — Calculation Type

FEATURES

A conventional Digimatic indicator simply displays spindle displacement, but the Calculation-Type Digimatic indicator displays the result of an internal calculation based on spindle displacement. With fixtures, measurements such as feeler, inside diameter and radius of curvature measurement can easily be obtained without the hassle of conversion tables or equivalents.

- Calculations are performed using the formula $Ax+B+Cx^{-1}$ ('x' is spindle displacement) while the specified coefficients A, B and, C can be set with respect to the purpose of measurement or dimensions of the fixture. This unique features allows you to read derived measurements directly, without fumbling for conversions.



543-285B

SPECIFICATIONS

Metric			
Resolution	Order No.*	Range	Accuracy
0.0002 - 1mm (switchable)	543-285B	12.7mm	0.003mm
	543-480B	25.4mm	0.003mm
	543-485B	50.8mm	0.006mm

*Flat back

ISO/JIS type

ANSI/AGD type

Inch/Metric			
Resolution	Order No.*	Range	Accuracy
.00001" - .05"/ 0.0002 - 1mm (switchable)	543-286B	.5"	.00012"
	543-287B	.5"	.00012"
	543-481B	1"	.00012"
	543-482B	1"	.00012"
	543-486B	2"	.00025"
	543-487B	2"	.00025"

*Flat back

DIMENSIONS

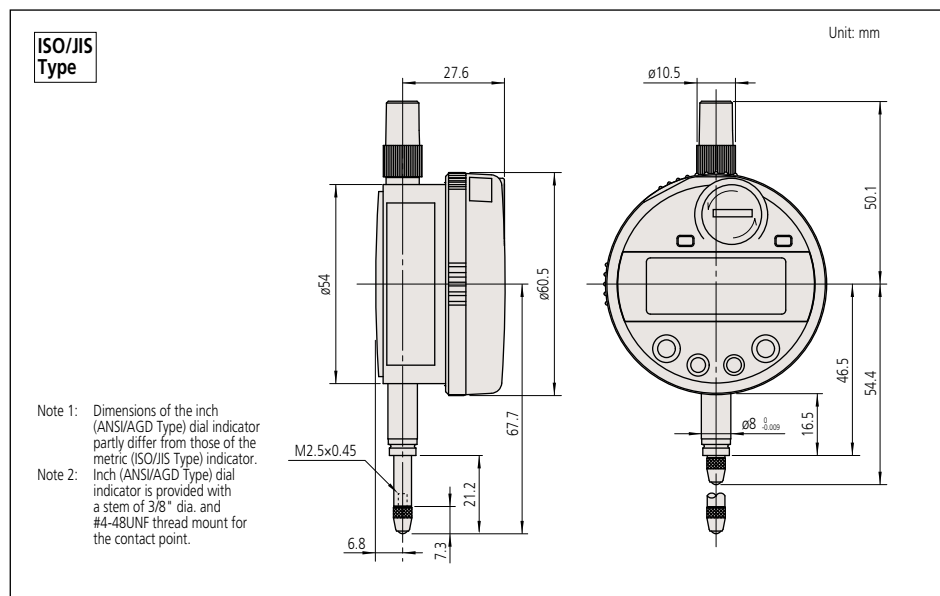

(Refer to page IX for details.)

Technical Data

- Accuracy: Refer to the list of specifications (excluding quantizing error)
- Resolution: 0.0002mm - 1mm or .00001" - .05"/0.0002mm - 1mm
- Display: LCD Character Height 6.5mm
- Scale type: ABSOLUTE electrostatic linear encoder
- Max. response speed: Unlimited
- Measuring force: 1.5N or less
- Stem dia.: 8mm (ISO/JIS type) or 3/8" (ANSI/AGD type)
- Contact point: Carbide ball with M2.5x0.45 (ISO/JIS type) Carbide ball with #4-48UNF (ANSI/AGD type)
- Battery: SR44 (1 pc.), 938882
- Battery life: Approx. 12 months under normal use

Function

- Origin-set/Presets, Zero set, GO/NG judgment, Power ON/OFF, Data output, inch/mm conversion (inch/mm models)
- Max/Min value holding, Function lock, Data hold
- Alarm: Low voltage, Counting value composition error, Overflow error, Tolerance limit setting error

Optional Accessories

- 905338: SPC cable (1m)
- 905409: SPC cable (2m)
- 02AZD790F: SPC cable for U-WAVE(160mm)
- 902011: Spindle lifting lever (ISO/JIS type)
- 540774: Spindle lifting cable
- : Backs (See page F-40.)
- : Contact points (See page F-36.)

APPLICATIONS



- Various fixtures suited for individual workpieces can be prepared.
- Measuring accuracy is subject to fixture accuracy

ABSOLUTE Digimatic Indicator ID-C

SERIES 543 — Signal Output Function Type



(Refer to page IX for details.)

Technical Data

Accuracy: Refer to the list of specifications (excluding quantizing error)
 Resolution: 0.001mm, .00005"/0.001mm or .0001"/0.001mm
 Display: LCD Character Height 8.5mm
 Scale type: ABSOLUTE electrostatic linear encoder
 Max. response speed: Unlimited
 Measuring force: 2.0N or less
 Stem dia.: 8mm (ISO/JIS type) or 3/8" (ANSI/AGD type)
 Contact point: Carbide ball with M2.5x0.45 (ISO/JIS type)
 Carbide ball with #4-48UNF (ANSI/AGD type)
 Power supply: DC 12 - 24V±10%
 Dust/Water protection level: IP54

Function

Signal output (-NG/OK/+NG, NPN open collector), Remote control (hold-reset, preset-recall, zero-set), Origin-set/Preset, Zeroret, GO/±NG judgment, Max/Min/Runout value holding, Counting direction switching, Power ON/OFF, inch/mm conversion (inch/mm models)
 Alarm: Low voltage, Counting value composition error, Overflow error, Tolerance limit setting error

Optional Accessories

902011: Spindle lifting lever* (ISO/JIS type)
902794: Spindle lifting lever* (ANSI/AGD type)
540774: Spindle lifting cable*
02ACA376: Rubber boot
 *Backs (See page F-40.)
 *Contact points (See page F-36.)

*When using the spindle lifting lever/cable, IP54 is not guaranteed.

Output pattern

Wire	-NG	OK	+NG	Composition error
Orange (-NG)	Low	High	High	High
Green (OK)	High	Low	High	High
Brown (+NG)	High	High	Low	High
LED	Red	Green	Red	Red (blinking)
LCD	<	O	>	"xxxE" indication

I/O Specifications

Wire	Signal	I/O	Description
Black	-V (GND)	—	Connected to minus (-) terminal
Red	+V (GND)	I	Power supply (12 - 24VDC)
Orange	-NG	O	Tolerance judgment result output: Only the terminal corresponding to a judgment result is set to the low level.
Green	OK	O	
Brown	+NG	O	
Yellow	PRESET_RECALL ZERO	I	External input terminal: If the relevant terminal is set to the low level, its signal becomes true.
Blue	HOLD_RESET	I	
Shield	FG	—	Connected to GND

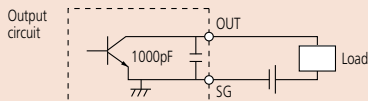

Output voltage: Max. 24V
 Output current: Max. 30mA
 Output saturated voltage: Max. 0.3V

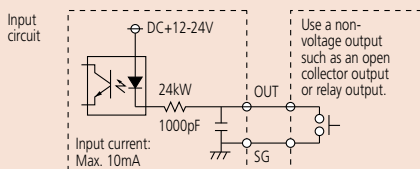

Use a non-voltage output such as an open collector output or relay output.

Input current: Max. 10mA

FEATURES

- With the Max/Min Value holding function, the Signal ID-C indicator can output a GO/±NG judgment result against the tolerance values set. Substituting for the traditional mechanical/electrical contact, the judgment is carried out by direct numerical comparison with the peak measurement data obtained. This provides high reliability with no drift of tolerance value setting.
- The judgment signal can be output to an external device, such as a sequencer, through the NPN open-collector connection.
- The GO/±NG judgment result is also indicated by a green/red LED and "<, O, >" symbols on the LCD.
- Employing the ABSOLUTE linear encoder, the Signal ID-C always displays the spindle "Absolute Position" from the origin at power-on. Also unlimited response speed eliminates over-speed errors.
- The Signal ID-C achieves IP54 protection level to resist dust and contaminants for safe operation in harsh machine shop environments.



543-280



SPECIFICATIONS

Metric	Order No. (w/ lug, flat-back)	Range	Accuracy	Measuring force	Remarks
Resolution	543-280	12.7mm	0.003mm	2.0N or less	—

ISO/JIS type ANSI/AGD type

Inch/Metric	Order No. (w/ lug, flat-back)	Range	Accuracy	Measuring force	Remarks
Resolution	543-281 543-281B	.5"	.00012"	2.0N or less	—
Resolution	543-282 543-282B	.5"	.00012"	2.0N or less	—
Resolution	543-283 543-283B	.5"	.00012"	2.0N or less	—

DIMENSIONS

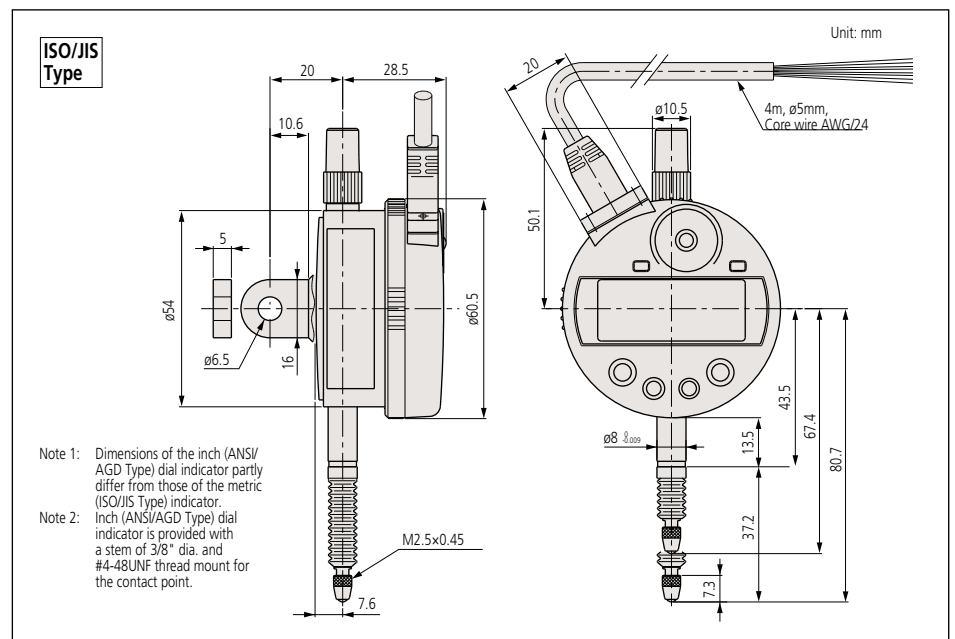

ABSOLUTE Digimatic Indicator ID-C

SERIES 543 — Peak-Value Hold Type

This is the Max/Min value holding function model in the ID-C Digimatic Indicator Series.

FEATURES

- The maximum, minimum, or runout value can be displayed during measurement.
- GO/±NG judgment is performed by setting the upper and lower tolerances for max., min. and runout values.
- High speed sampling rate of 50 times/s.



543-262

SPECIFICATIONS

Metric				
Resolution	Order No. (w/lug, flat-back)		Range	Accuracy
0.001mm	543-260	543-260B	12.7mm	0.003mm

ISO/JIS type ANSI/AGD type

Inch/Metric				
Resolution	Order No. (w/lug, flat-back)		Range	Accuracy
.00005" /0.001mm	543-261	543-261B	.5"	.00012"
.00005" /0.001mm	543-262	543-262B	.5"	.00012"
.0001" /0.001mm	543-263	543-263B	.5"	.00012"

DIMENSIONS

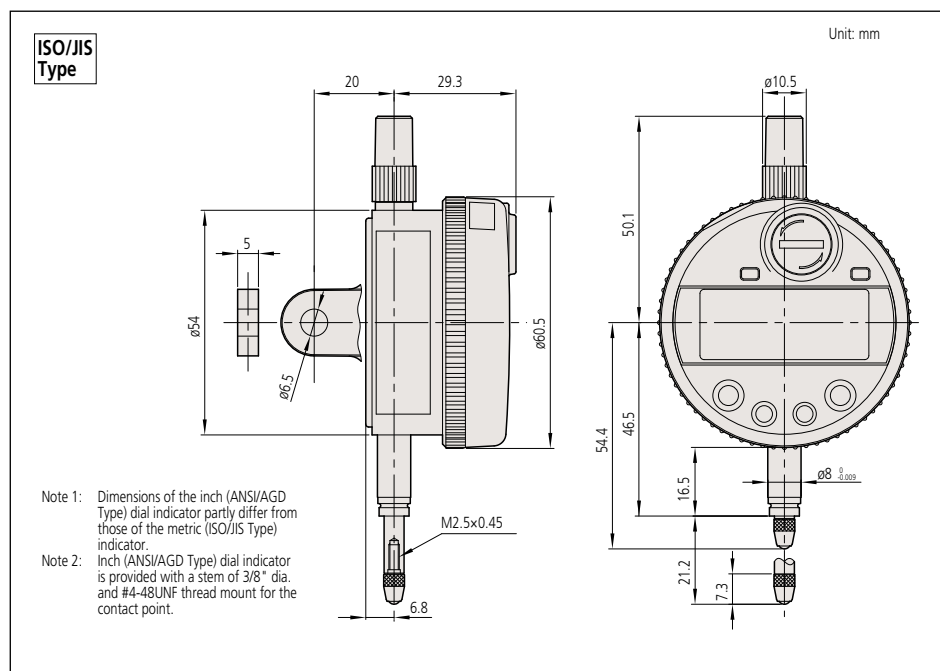

(Refer to page IX for details.)

Technical Data

Accuracy: Refer to the list of specifications (excluding quantizing error)

Resolution: 0.001mm, .00005"/0.001mm or .0001"/0.001mm

Display: LCD Character Height 8.5mm

Scale type: ABSOLUTE electrostatic linear encoder

Max. response speed: Unlimited

Measuring force: 1.5N or less

Stem dia.: 8mm (ISO/JIS type) or 3/8" (ANSI/AGD type)

Contact point: Carbide ball with M2.5x0.45 (ISO/JIS type) Carbide ball with #4-48UNF (ANSI/AGD type)

Battery: SR44 (2 pcs.), **938882**

Battery life: Approx. 800 - 1300 hours under normal use

Dust/Water protection level: IP42

Function

Preset, Zeraset, GO/±NG judgment, Max/Min/Runout value holding, Counting direction switching, Power ON/OFF, Data output, inch/mm conversion (inch/mm models)

Alarm: Low voltage, Counting value composition error, Overflow error, Tolerance limit setting error

Optional Accessories

- 905338:** SPC cable (1m)
- 905409:** SPC cable (2m)
- 02AZD790F:** SPC cable for U-WAVE(160mm)
- 902011:** Spindle lifting lever (ISO/JIS type)
- 902794:** Spindle lifting lever (ANSI/AGD type)
- 540774:** Spindle lifting cable
- Backs (See page F-40.)
- Contact points (See page F-36.)



(Refer to page IX for details.)

Technical Data

Accuracy: Refer to the list of specifications (excluding quantizing error)
 Resolution: 0.001mm or .00005"/0.001mm
 Display: LCD Character Height 8.5mm
 Scale type: ABSOLUTE electrostatic linear encoder
 Max. response speed: Unlimited
 Measuring force: 1.5N or less
 Stem dia.: 8mm (ISO/JIS type) or 3/8" (ANSI/AGD type)
 Contact point: Carbide ball with M2.5x0.45 (ISO/JIS type)
 Carbide ball with #4-48UNF (ANSI/AGD type)
 Battery: SR44 (2 pcs.), **938882**
 Battery life: Approx. 2000 hours under normal use
 Dust/Water protection level: IP42

Function

Preset, GO/±NG judgment, Power ON/OFF, Data output, inch/mm conversion (inch/mm models)
 Min value holding, Data hold
 Alarm: Low voltage, Counting value composition error, Overflow error, Tolerance limit setting error

Optional Accessories

905338: SPC cable (1m)
905409: SPC cable (2m)
02AZD790F: SPC cable for U-WAVE(160mm)
526-170: Bore gage probe (0.95 - 1.55mm)
526-160: Bore gage probe (1.5 - 4.0mm)
526-150: Bore gage probe (3.7 - 7.3mm)
526-101: Bore gage probe (7.0 - 10.0mm)
526-102: Bore gage probe (10 - 18mm)
511-126: Bore gage probe (18 - 35mm)
511-127: Bore gage probe (35 - 60mm)
511-132: Bore gage probe (50 - 150mm)



Installed on bore gage probe (511-331)

ABSOLUTE Digimatic Indicator ID-C

SERIES 543 — Bore Gage Type

This ID-C Series Digimatic Indicators are exclusively designed for ID measurement applications when fitted to bore gauges.

FEATURES

- The minimum value holding function provides easy detection of true hole diameter.
- An analog bar indicator is integrated to enhance the reading ergonomics.
- GO/±NG judgment is performed by setting upper and lower tolerances.
- Up to three sets of master value and upper/lower tolerance values can be memorized.



543-264B

SPECIFICATIONS

Metric			
Resolution	Order No.*	Range	Accuracy
0.001mm	543-264B	12.7mm	0.003mm

*Flat back

Metric/Inch			
Resolution	Order No.*	Range	Accuracy
0.001mm/.00005"	543-265B	12.7mm	0.003mm
0.001mm/.0001"	543-267B	12.7mm	0.003mm

*Flat back

Inch/Metric			
Resolution	Order No.*	Range	Accuracy
.00005"/0.001mm	543-266B	.5"	.00012"

*Flat back

ISO/JIS type ANSI/AGD type

DIMENSIONS

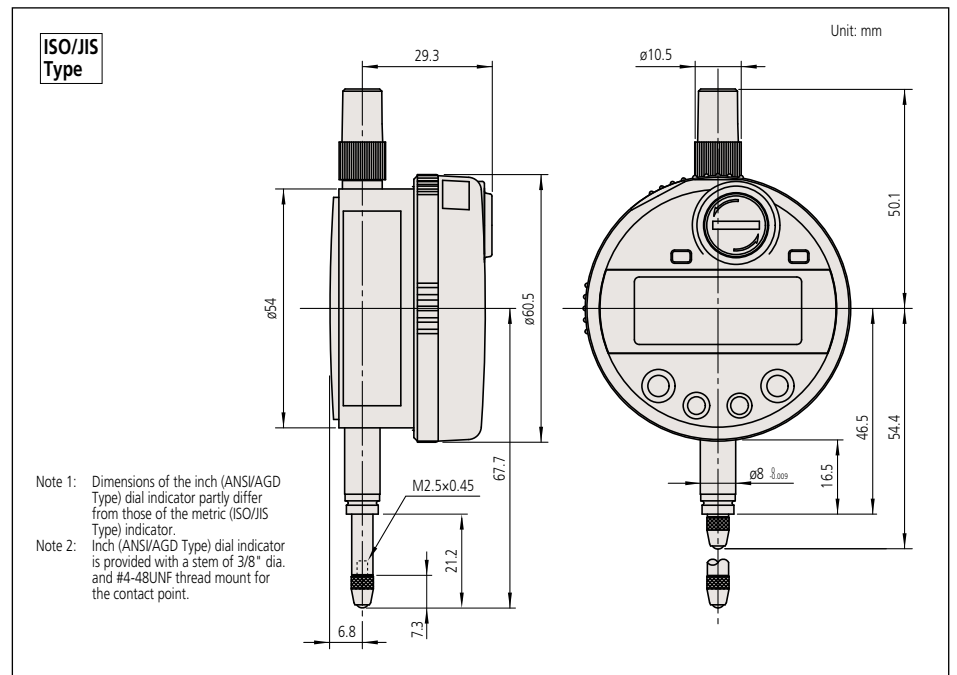

ABSOLUTE Digimatic Indicator ID-H

SERIES 543 — High Accuracy and High Functional Type

FEATURES

- This new-generation digital indicator offers the excellent accuracy and functionality expected from the top class of indicator. Take advantage of its high accuracy backed up by 0.5 μ m / .00002" resolution, remote control functionality via a handheld controller (or an RS-232C interface) and easy runout measurements with the well-established analog bar display.
- Maximum, minimum, or runout values can be displayed during measurement.
- GO/ \pm NG judgment is performed by setting upper and lower tolerances. If a judgment result shows an out of tolerance condition, the display backlighting changes from green to red, so tolerance judgment can be made at a glance.
- SPC data output.
- RS-232C input/output



Remote controller (optional)



543-561

543-563

SPECIFICATIONS

Metric			
Resolution	Order No.*	Range	Accuracy
0.0005mm, 0.001mm	543-561	30.4mm	0.0015mm
	543-563	60.9mm	0.0025mm

* To denote your AC power cable add the following suffixes to the order No.: **A** for UL/CSA, **D** for CEE, **DC** for CCC, **E** for BS, **K** for EK, **No suffix** is required for JIS/100V

Inch/Metric			
Resolution	Order No.*	Range	Accuracy
.00005", .0001", 0.0005mm, 0.001mm	543-562	1.2"	0.0015mm
	543-564	2.4"	0.0025mm

* To denote your AC power cable add the following suffixes to the order No.: **A** for UL/CSA, **D** for CEE, **DC** for CCC, **E** for BS, **K** for EK, **No suffix** is required for JIS/100V

Tolerance judgment



Analog bar display



Max/Min value measurement



Runout measurement



Resolution switching



DIMENSIONS

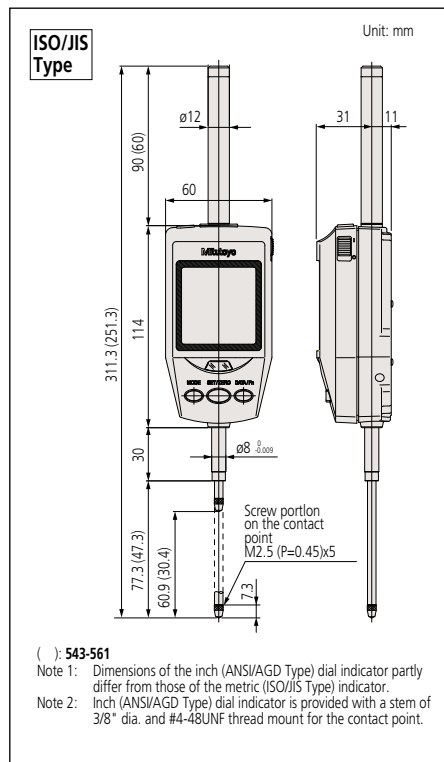

(Refer to page IX for details.)

Technical Data

- Accuracy: Refer to the list of specifications (excluding quantizing error)
- Resolution: 0.0005mm/0.001mm or .00002"/.00005"/.0001"/0.0005mm/0.001mm
- Display: LCD Character Height 9.5mm
- Scale type: Photoelectric linear encoder
- Max. response speed: 1000mm/s
- Measuring force: 2.0N/2.5N* or less (*60mm range models)
- Stem dia.: 8mm (ISO/JIS type) or 3/8" (ANSI/AGD type)
- Contact point: Carbide ball with M2.5x0.45 (ISO/JIS type) Carbide ball with #4-48UNF (ANSI/AGD type)
- Power supply: 6V DC (via AC adaptor)

Functions

- Preset, Zeraset, GO/ \pm NG judgment, Max/Min value hold, Runout measurement, Resolution switching, Counting direction switching, Power ON/OFF, Data output, inch/mm conversion (inch/mm models)
- Function lock, Data hold
- Alarm: Counting value composition error, Overflow error, Tolerance limit setting error

Optional Accessories

- 936937: SPC cable (1m)
- 965014: SPC cable (2m)
- 02AZD790E: SPC cable for U-WAVE(160mm)
- 21EAA131: RS-232C cable (2m)
- 21EZA099: Remote controller
- 540774: Spindle lifting cable (stroke: 30mm)
- 21EZA101: Spindle lifting knob
- 264-504: Digimatic Min-processor DP-1VR
- 543-004: Digimatic presetter
- 215-154: Granite comparator stand
- 215-504: Comparator stand
- 215-821: Comparator stand
- Backs (See page F-40.)
- Contact points (See page F-36.)

*Required when orienting the indicator upside down.

Application

Difference/Runout measurement

Example: Indicator travel from points A to D

Difference (or Total Runout) is displayed as A. Dimensions B (maximum value) and C (minimum value) can be recalled from memory with a simple key sequence.

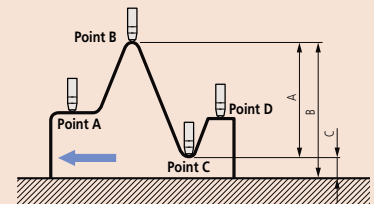



Absolute System Patented by MITUTOYO

(Refer to page IX for details.)

Technical Data

Accuracy: Refer to the list of specifications (excluding quantizing error)
 Resolution: 0.01mm/0.001mm or .00005"/.0001"/.0005"/.001"/0.001mm/0.01mm
 Display: LCD Character Height 8.5mm
 Scale type: ABSOLUTE electrostatic linear encoder
 Max. response speed: Unlimited
 Measuring force: 1.8N/2.3N* or less (*50mm range models)
 Stem dia.: 8mm (ISO/JIS type) or 3/8" (ANSI/AGD type)
 Contact point: Carbide ball with M2.5x0.45 (ISO/JIS type) Carbide ball with #4-48UNF (ANSI/AGD type)
 Power supply: 9V DC (via AC adaptor)

Functions

Preset, Zeroset, GO/±NG judgment, Max/Min value hold, Runout measurement, Resolution switching, Counting direction switching, Power ON/OFF, Data output, inch/mm conversion (inch/mm models)
 Alarm: Counting value composition error, Overflow error, Tolerance limit setting error

Optional Accessories

936937: SPC cable (1m)
 965014: SPC cable (2m)
 02AZD790E: SPC cable for U-WAVE(160mm)
 540774: Spindle lifting cable (stroke: 25mm)
 02ACA571: Auxiliary spindle spring for 25mm/1" models*
 02ACA773: Auxiliary spindle spring for 50mm/2" models*
 264-504: Digimatic Min-processor DP-1VR
 543-004-1: Digimatic presetter
 215-154: Granite comparator stand
 215-504: Comparator stand
 215-821: Comparator stand
 —: Backs (See page F-40.)
 —: Contact points (See page F-36.)

*Required when orienting the indicator upside down.

Application

Difference/Runout measurement

Example: Indicator travel from points A to D

Difference (or Total Runout) is displayed as A. Dimensions B (maximum value) and C (minimum value) can be recalled from memory with a simple key sequence.

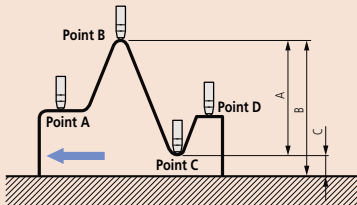

ABSOLUTE Digimatic Indicator ID-F

SERIES 543 — with Back-lit LCD Screen

FEATURES

- With the ABSOLUTE Linear Encoder technology, once the measurement reference point has been set it will not be lost when the power is turned off.
- GO/±NG judgment is performed by setting upper and lower tolerances. If a judgment result shows an out of tolerance condition, the display backlighting changes from green to red, so tolerance judgment can be made at a glance.



- The maximum, minimum, or runout value can be displayed during measurement.
- An analog bar indicator has been integrated to handle upper/lower limit approaching and zero approaching. It enhances the ease of operation in the same manner as a dial indicator. The display range of the analog bar can be changed.
- SPC data output.



SPECIFICATIONS

Metric			
Resolution	Order No.*	Range	Accuracy
0.001mm, 0.01mm	543-551	25mm	0.003mm
	543-557	50mm	0.003mm
	543-553	50mm	0.006mm

* To denote your AC power cable add the following suffixes to the order No.: **A** for UL/CSA, **D** for CEE, **DC** for CCC, **E** for BS, **K** for EK, **No suffix** is required for JIS/100V

Inch/Metric			
Resolution	Order No.*	Range	Accuracy
.00002", .00005", .0001", .0005", .001", 0.001mm, 0.01mm	543-552	1"	.00012"
	543-558	2"	.00012"
	543-554	2"	.00024"

* To denote your AC power cable add the following suffixes to the order No.: **A** for UL/CSA, **D** for CEE, **DC** for CCC, **E** for BS, **K** for EK, **No suffix** is required for JIS/100V

DIMENSIONS

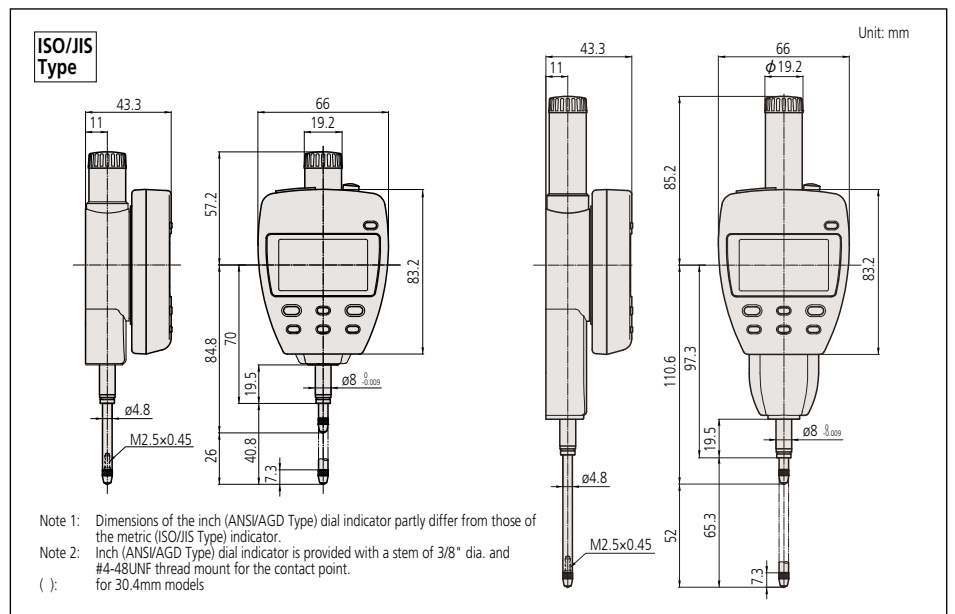

ABSOLUTE Digimatic Indicator ID-N/B

SERIES 543 — with Dust/Water Protection Conforming to IP66

FEATURES

- Proven ABSOLUTE sensor.
- Rated to IP66 water- and dust-proofing standard and oil resistance improved.
- Slim body design is advantageous for multi-point measurements.
- Improvement in workability with the LCD readout-rotation function.
- Back plunger design (ID-B).
- Built-in tolerance judgment function.
- Switchable resolution.
- Waterproof data output connector.
- Built-in hold/preset function



Slim type ID-N
543-575

Back plunger type ID-B
543-585

SPECIFICATIONS

Metric				
Resolution	Order No.	Range	Accuracy	Remarks
0.01mm	543-570	12.7mm	0.02mm	Slim type ID-N
0.01mm	543-580	5.0mm	0.02mm	Back plunger type ID-B
0.01mm / 0.001mm	543-575	12.7mm	0.01mm / 0.003mm	Slim type ID-N
0.01mm / 0.001mm	543-585	5.0mm	0.01mm / 0.003mm	Back plunger type ID-B

Inch/Metric				
Resolution	Order No.	Range	Accuracy	Remarks
.0005", 0.01mm	543-571	.5"	.0008"	Slim type ID-N
	543-581	.2"	.0008"	Back plunger type ID-B
0.01mm / 0.001mm .0005" / .00005"	543-576	.5"	.0004" / .00012"	Slim type ID-N
	543-586	.2"	.0004" / .00012"	Back plunger type ID-B

DIMENSIONS

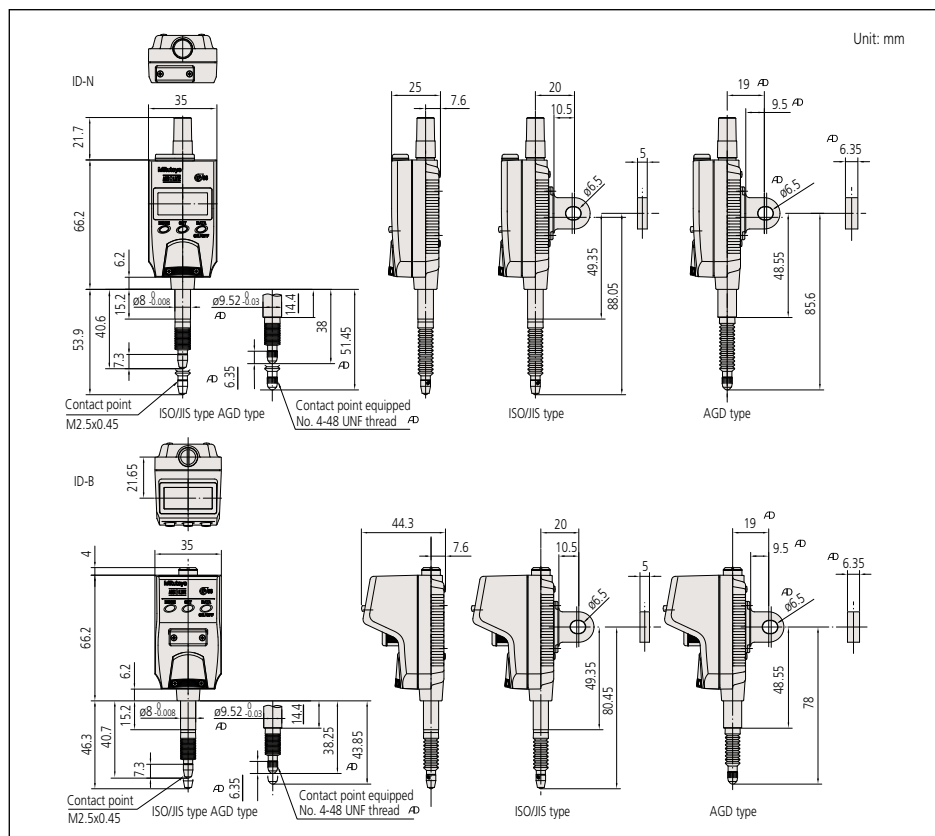

(Refer to page IX for details.)



(Refer to the page IX for details.)



Technical Data

Accuracy: Refer to the list of specifications (excluding quantizing error)

Resolution: 0.01mm, 0.01mm/0.001mm, .0005"/0.01mm or .0005"/.00005"/0.01mm/0.001mm

Display: LCD Character Height 6.2mm

Scale type: ABSOLUTE electrostatic linear encoder

Max. response speed: Unlimited

Measuring force: 2.5N (2.0N: Back plunger type)

Stem dia.: 8mm (3/8": inch/metric models)

Contact point: Carbide ball with M2.5x0.45 (#4-48UNF: inch/metric models)

Battery: SR44 (1 pc.), **938882**

Battery life: Approx. 7000 hours under normal use

Dust/Water protection level: IP66

Functions

Zero-setting, Presetting, Direction switching, Tolerance judgment, Display hold, Data output, inch/mm conversion (inch/mm models)

Alarm: Low voltage, Counting value composition error, Overflow error, Tolerance limit setting error

Optional Accessories

- 21EZA105: Lifting knob (for ISO/JIS model)
- 21EZA150: Lifting knob (for AGD model)
- 21EZA145: Lug (for JIS/ISO model)
- 21EZA146: Lug (for AGD model)
- 02ACA376: Rubber boot (for ID-N, NBR)
- 238774: Rubber boot (for ID-N, silicon)
- 125317: Rubber boot (for ID-B, NBR)
- 21EAA212: Rubber boot (for ID-B, silicon)
- 21EAA194: SPC cable (1m)
- 21EAA190: SPC cable (2m)
- 02AZD790G: SPC cable for U-WAVE(160mm)
- 21EAA210: Bifurcated connecting cable with zero-setting terminal (1m)
- 21EAA211: Bifurcated connecting cable with zero-setting terminal (2m)
- : Contact points (See page F-36.)

Lifting knob



Application examples

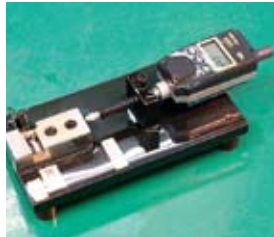

EC Counter

SERIES 542 — Low-cost, Assembly, Type Display Unit

FEATURES

- Employs the DIN size (96 X 48mm) and mount-on-panel configuration, which greatly facilitates incorporation into a system.
- Can be set to produce either tolerance judgment output or Digimatic output.
- With preset and GO/±NG judgment function



542-007

DIMENSIONS

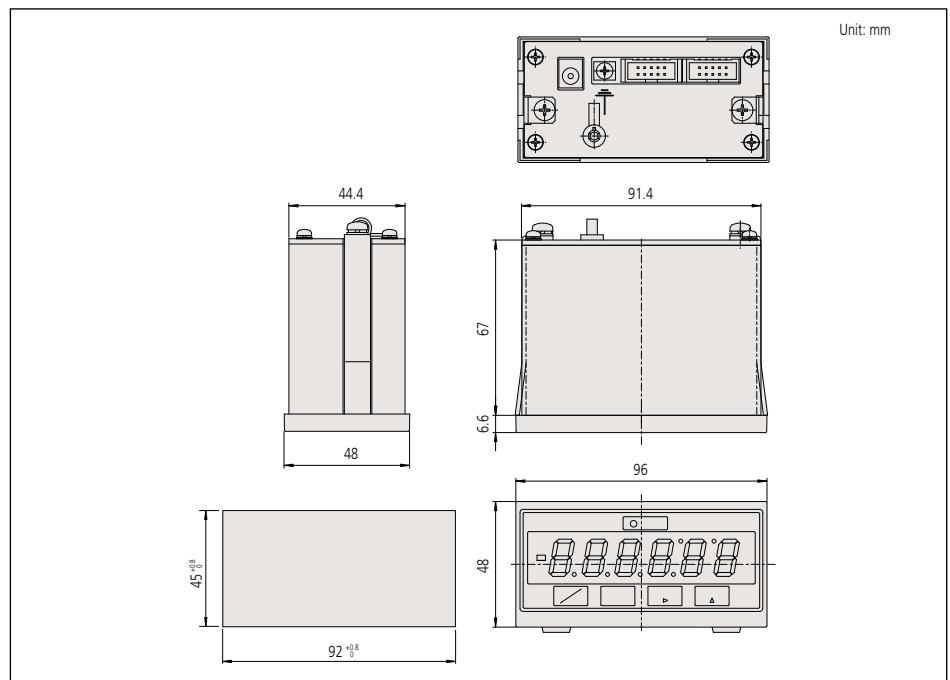

Dial Indicators

FEATURES: S Series (Series 2, 3, 4)

- Revolutionary stem-bush design for trouble-free stem clamping (longer clamping range; maximum clamp torque at the clamping point with M5 screw: 150N-cm)
- No through screw-hole on the frame for high dust-resistance.

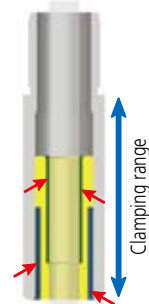

Clearance to avoid direct influence of clamping force

- Involute curved lifting lever for smooth movement of spindle and dovetail joint for tool-less connection.
- Greater rigidity in the bearing plate for reducing retrace error (20%) and 4-screw mounting for increased impact resistance.

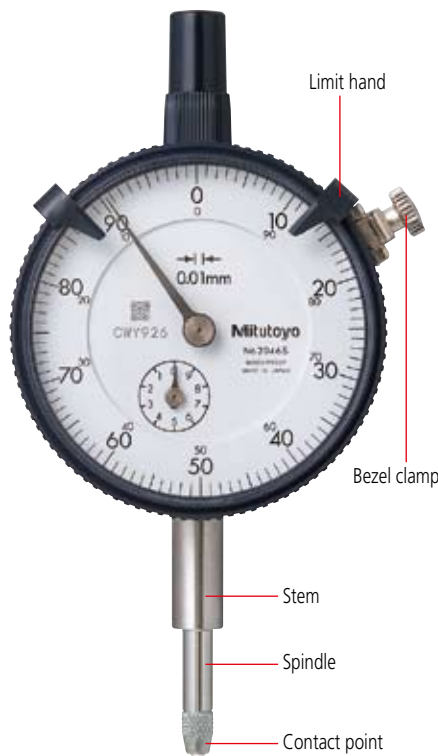
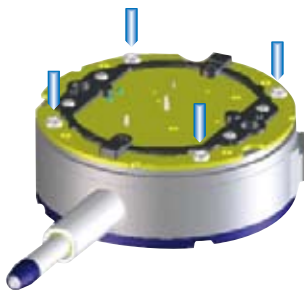

Feature icons

Icon	Feature description
	Reverse reading type suitable for depth and step measurement.
	One revolution type for easy and error-free reading
	Double scale spacing type, easy-on-the-eyes
	Shockproof type
	Waterproof type (IP63)
	Waterproof type (IP64)
	With damper at lowest rest point
	Jeweled bearing type
	Peak retaining type
	Long stem type
	Dustproof type
	With coaxial revolution counter
	Back plunger type
	Adjustable hand type
	Double-face type

*Mitutoyo produces ASME-compatible products. Contact us for details.

Dial Indicator

SERIES 1 — Compact One Revolution Type for Error-free Reading



(Refer to page IX for details.)



1929S
1929S-60
1929S-62



1900S-10
1900S-70
1900S-72



One revolution type



1929S

Unlike many other dial indicators, the one-revolution dial indicator literally shows the entire spindle travel or range as one sweep of the hand, eliminating the possibility of reading errors due to miscounting multiple revolutions. With one-revolution dial indicators, "within tolerance" and "out-of-tolerance" can never be misinterpreted. A unique shock-proof mechanism is incorporated, providing improved immunity to shock due to sudden spindle retraction caused by high impact.



Double scale spacing type



Jeweled bearing type



Shockproof type



Dustproof type



Waterproof type

FEATURES

Metric

Order No.	w/ lug	Flat-back						—
1929S	1929SB	—	—	—	—	—	—	—
1929S-60	1929SB-60	—	—	✓	—	—	—	—
1929S-62	1929SB-62	—	—	—	✓	—	—	—
1900S-10	1900SB-10	—	✓	—	—	—	—	—
1900S-70	1900SB-70	—	✓	✓	—	—	—	—
1900S-72	1900SB-72	—	✓	—	✓	—	—	—

Inch

Order No.	w/ lug	Flat-back						—
1909S-62	1909SB-62	—	—	—	✓	—	—	—
1910S-72	1910SB-72	—	—	—	✓	—	—	—

SPECIFICATIONS

Metric

ISO/JIS type

Graduation	Order No.		Range (range/rev)	Accuracy				Repeatability	Dial reading	Measuring force
	w/ lug	Flat-back		Overall	Retrace	1/10 Rev	1 Rev			
0.01mm	1929S	1929SB	1mm / 1.4mm	±11µm	6µm	7µm	—	5µm	50-0-50	1.4N or less
0.01mm	1929S-60	1929SB-60	1mm / 1.4mm	±11µm	6µm	7µm	—	5µm	50-0-50	2.0N or less
0.01mm	1929S-62	1929SB-62	1mm / 1.4mm	±11µm	6µm	7µm	—	5µm	50-0-50	1.4N or less
0.001mm	1900S-10	1900SB-10	0.1mm / 0.14mm	±6µm	4µm	5µm	—	1µm	50-0-50	1.5N or less
0.001mm	1900S-70	1900SB-70	0.1mm / 0.14mm	±6µm	4µm	5µm	—	1µm	50-0-50	2.0N or less
0.001mm	1900S-72	1900SB-72	0.1mm / 0.14mm	±6µm	4µm	5µm	—	1µm	50-0-50	1.5N or less

Inch

ANSI/AGD type

Graduation	Order No.		Range (range/rev)	Accuracy		Repeatability	Dial reading	Measuring force
	w/ lug	Flat-back		First 1 Rev / 2.5 Rev / 10 Rev	Retrace			
.0005"	1909S-62	1909SB-62	.04" / .056"	±.0005" / — / —	.00016"	±.0001"	20-0-20	1.4N or less
.0001"	1910S-72	1910SB-72	.006" / .008"	±.0001" / — / —	.0001"	±.00003"	3-0-3	1.5N or less

Optional Accessories

- : Backs (See page F-40.)
- : Contact points (See page F-36.)

DIMENSIONS

ANSI/AGD Type

ISO/JIS Type

Unit: mm

Note 1: Dimensions of the inch (ANSI/AGD Type) dial indicator partly differ from those of the metric (ISO/JIS Type) indicator.
 Note 2: Inch (ANSI/AGD Type) dial indicator is provided with a stem of 3/8" dia. and #4-48UNF thread mount for the contact point.

Order No.	A	B	C	D	E	F	G	H	I
1929S	32.5	47.5	40	14.5	20	13.8	13.7	38	6.6
1929S-60	32.5	55.5	40	14.5	20	12.2	23.3	38	6.6
1929S-62	32.5	47.5	40	14.5	20	13.8	13.7	38	6.6
1900S-10	32.5	53.5	40	14.5	20	16.8	16.7	38	6.6
1900S-70	32.5	54.5	40	14.5	20	12.2	22.3	38	6.6
1900S-72	32.5	53.5	40	14.5	20	16.8	16.7	38	6.6

Dial Indicator

SERIES 1 — Compact Type

Mitutoyo's Series 1 dial indicators offer accuracy and durability for shop applications demanding highly accurate measurements where space is limited. The spindle is made of hardened stainless steel for durability, while the rack gear is machine ground for a tighter fit and increased accuracy.



(Refer to page IX for details.)

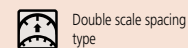
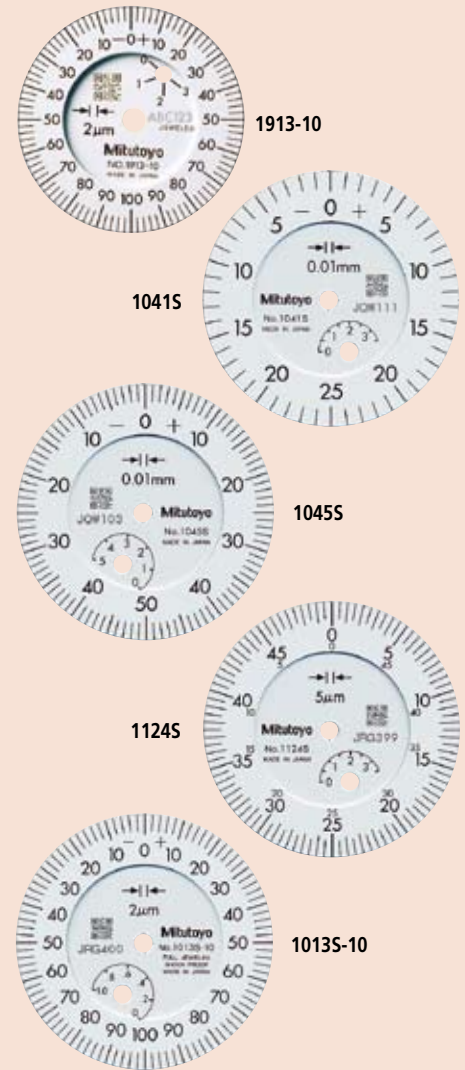

Double scale spacing type



Jeweled bearing type



Shockproof type



Dustproof type



Waterproof type

SPECIFICATIONS

Metric		ISO/JIS type									
Graduation	Order No.		Range (range/rev)	Accuracy				Repeat-ability	Dial reading	Measuring force	
	w/ lug	Flat-back		Overall	Retrace	1/10 Rev	1 Rev				
0.01mm	1911	1911B	2.5mm (1mm)	±12µm	6µm	7µm	±10µm	5µm	0-50-0	1.8N or less	
0.002mm	1913-10	1913B-10	0.5mm (0.2mm)	±8µm	5µm	6µm	±7µm	2µm	0-100-0	1.8N or less	
0.01mm	1003	1003B	4mm (1mm)	±13µm	6µm	8µm	±11µm	5µm	0-50-0	1.4N or less	
0.01mm	1044S	1044SB	5mm (1mm)	±13µm	6µm	8µm	±11µm	5µm	0-100	1.4N or less	
0.01mm	1045S	1045SB	5mm (1mm)	±13µm	6µm	8µm	±11µm	5µm	0-50-0	1.4N or less	
0.01mm	1044S-15	1044SB-15	5mm (1mm)	±13µm	6µm	8µm	±11µm	5µm	0-100	0.4N or less*	
0.01mm	1044S-60	1044SB-60	5mm (1mm)	±13µm	6µm	8µm	±11µm	5µm	0-100	2.0N or less	
0.01mm	1040S	1040SB	3.5mm (0.5mm)	±13µm	6µm	8µm	±11µm	5µm	0-50	1.4N or less	
0.01mm	1041S	1041SB	3.5mm (0.5mm)	±13µm	6µm	8µm	±11µm	5µm	0-25-0	1.4N or less	
0.005mm	1124S	1124SB	3.5mm (0.5mm)	±13µm	6µm	8µm	±11µm	5µm	0-50	1.4N or less	
0.001mm	1109S-10	1109SB-10	1mm (0.2mm)	±7µm	5µm	5µm	±6µm	1µm	0-100-0	1.5N or less	
0.002mm	1013S-10	1013SB-10	1mm (0.2mm)	±10µm	5µm	7µm	±8µm	1µm	0-100-0	1.5N or less	

*Use in a vertical position only (contact point downward).

FEATURES

Metric		ISO/JIS type						
Order No.	Flat-back	Double scale spacing type	Jeweled bearing type	Shockproof type	Dustproof type	Waterproof type	—	
								w/ lug
1911	1911B	—	—	—	—	—	—	
1913-10	1913B-10	—	✓	—	—	—	—	
1003	1003B	—	—	—	—	—	—	
1044S	1044SB	—	—	—	—	—	—	
1045S	1045SB	—	—	—	—	—	—	
1044S-15	1044SB-15	—	✓	—	—	—	—	
1044S-60	1044SB-60	—	—	✓	—	—	—	
1040S	1040SB	✓	—	—	—	—	—	
1041S	1041SB	✓	—	—	—	—	—	
1124S	1124SB	—	✓	—	—	—	—	
1109S-10	1109SB-10	—	✓	—	—	—	—	
1013S-10	1013SB-10	—	✓	—	—	—	—	



Double scale spacing type



Jeweled bearing type



Waterproof type



Shockproof type



Dustproof type

FEATURES

Inch							—
Order No.	Flat-back						—
1921	1921B	—	—	—	—	—	—
1923	1923B	—	✓	—	—	—	—
1927-10	1927B-10	—	✓	—	—	—	—
1925-10	1925B-10	—	✓	—	—	—	—
1410S	1410SB	—	—	—	—	—	—
1411S	1411SB	—	—	—	—	—	—
1410S-10	1410SB-10	—	✓	—	—	—	—
1780S	1780SB	—	—	—	—	—	—
1781S	1781SB	—	—	—	—	—	—
1506S	1506SB	—	—	—	—	—	—
1507S	1507SB	—	—	—	—	—	—
1670S	1670SB	—	—	—	—	—	—
1671S	1671SB	—	—	—	—	—	—
1570S	1570SB	—	✓	—	—	—	—
1571S	1571SB	—	✓	—	—	—	—
1470S	1470SB	—	—	—	—	—	—
1471S	1471SB	—	—	—	—	—	—
1802S-10	1802SB-10	—	✓	—	—	—	—
1803S-10	1803SB-10	—	✓	—	—	—	—

SPECIFICATIONS

Graduation	Order No.		Range (range/rev)	Accuracy		Repeat-ability	Dial reading	Measuring force
	w/ lug	Flat-back		First 1 Rev / 2.5 Rev / 10 Rev	Retrace			
.001"	1921	1921B	.1" (.04")	±.001" / ±.001" / —	.0002"	±.0002"	0-20-0	1.8N or less
.0005"	1923	1923B	.05" (.02")	±.0005" / ±.0005" / —	.00016"	±.0001"	0-10-0	1.8N or less
.0001"	1927-10	1927B-10	.01" (.004")	±.0002" / ±.0002" / —	.0001"	±.00003"	0-2-0	1.8N or less
.0001"	1925-10	1925B-10	.025" (.01")	±.0002" / ±.0002" / —	.0001"	±.00003"	0-5-0	1.8N or less
.001"	1410S	1410SB	.25" (.1")	±.001" / ±.001" / —	.0002"	±.0002"	0-100	1.4N or less
.001"	1411S	1411SB	.25" (.1")	±.001" / ±.001" / —	.0002"	±.0002"	0-50-0	1.4N or less
.001"	1410S-10	1410SB-10	.25" (.1")	±.001" / ±.001" / —	.0002"	±.0002"	0-100	1.4N or less
.001"	1780S	1780SB	.125" (.05")	±.001" / ±.001" / —	.0002"	±.0002"	0-50	1.4N or less
.001"	1781S	1781SB	.125" (.05")	±.001" / ±.001" / —	.0002"	±.0002"	0-25-0	1.4N or less
.0005"	1506S	1506SB	.125" (.05")	±.0005" / ±.0005" / —	.00016"	±.0001"	0-50	1.4N or less
.0005"	1507S	1507SB	.125" (.05")	±.0005" / ±.0005" / —	.00016"	±.0001"	0-25-0	1.4N or less
.0005"	1670S	1670SB	.1" (.04")	±.0005" / ±.0005" / —	.00016"	±.0001"	0-40	1.4N or less
.0005"	1671S	1671SB	.1" (.04")	±.0005" / ±.0005" / —	.00016"	±.0001"	0-20-0	1.4N or less
.0005"	1570S	1570SB	.075" (.03")	±.0005" / ±.0005" / —	.00016"	±.0001"	0-30	1.4N or less
.0005"	1571S	1571SB	.075" (.03")	±.0005" / ±.0005" / —	.00016"	±.0001"	0-15-0	1.4N or less
.00025"	1470S	1470SB	.05" (.02")	±.00025" / ±.00025" / —	.000125"	±.0001"	0-20	1.4N or less
.00025"	1471S	1471SB	.05" (.02")	±.00025" / ±.00025" / —	.000125"	±.0001"	0-10-0	1.4N or less
.0001"	1802S-10	1802SB-10	.025" (.01")	±.0001" / ±.0001" / —	.0001"	±.00003"	0-10	1.5N or less
.0001"	1803S-10	1803SB-10	.025" (.01")	±.0001" / ±.0001" / —	.0001"	±.00003"	0-5-0	1.4N or less

ANSI/AGD type

Optional Accessories

- : Backs (See page F-40.)
- : Contact points (See page F-36.)

DIMENSIONS

ANSI/AGD Type

ISO/JIS Type

Note 1: Dimensions of the inch (ANSI/AGD Type) dial indicator partly differ from those of the metric (ISO/JIS Type) indicator.

Note 2: Inch (ANSI/AGD Type) dial indicator is provided with a stem of 3/8" dia. and #4-48UNF thread mount for the contact point.

Unit: mm

Order No.	A	B	C	D	E	F	G	H	I
1921	15.5	40	31	12.5	19	15	9.5	30	7
1923	15.5	38.3	31	12.5	19	15	7.8	30	7
1925-10	15.5	37.5	31	12.5	19	15	7	30	7
1927-10	15.5	37.2	31	12.5	19	15	6.7	30	7
1410S	32.5	47.6	40	14.5	19	12.8	14.8	38	6.6
1410S-10	32.5	47.6	40	14.5	19	12.8	14.8	38	6.6
1411S	32.5	47.6	40	14.5	19	12.8	14.8	38	6.6
1470S	32.5	42	40	14.5	19	12.8	9.2	38	6.6
1471S	32.5	42	40	14.5	19	12.8	9.2	38	6.6
1506S	32.5	44.4	40	14.5	19	12.8	11.3	38	6.6
1507S	32.5	44.4	40	14.5	19	12.8	11.3	38	6.6
1570S	32.5	42.7	40	14.5	19	12.8	9.9	38	6.6
1571S	32.5	42.7	40	14.5	19	12.8	9.9	38	6.6
1670S	32.5	43.4	40	14.5	19	12.8	10.6	38	6.6
1671S	32.5	43.4	40	14.5	19	12.8	10.6	38	6.6
1780S	32.5	44.1	40	14.5	19	12.8	11.3	38	6.6
1781S	32.5	44.1	40	14.5	19	12.8	11.3	38	6.6
1802S-10	32.5	41.3	40	14.5	19	8.5	9.9	38	6.6
1803S-10	32.5	41.3	40	14.5	19	8.5	9.9	38	6.6

Order No.	A	B	C	D	E	F	G	H	I
1911	15.5	42	31	12.5	19	15	11.5	30	7
1913-10	15.5	39.5	31	12.5	19	15	9	30	7
1003	20	40.3	36	13	15	9.5	12.8	32	6
1013S-10	32.5	49	40	14.5	20	13.8	15.2	38	6.6
1040S	32.5	46	40	14.5	20	13.8	12.2	38	6.6
1041S	32.5	46	40	14.5	20	13.8	12.2	38	6.6
1044S	32.5	47.5	40	14.5	20	13.8	13.7	38	6.6
1044S-15*2	32.5	47.5	40	14.5	20	13.8	13.7	38	6.6
1044S-60	32.5	57	40	14.5	20	12.2	24.8	38	6.6
1045S	32.5	47.5	40	14.5	20	13.8	13.7	38	6.6
1109S-10	32.5	49	40	14.5	20	13.8	15.2	38	6.6
1124S	32.5	46	40	14.5	20	13.8	12.2	38	6.6

*2 Use in a vertical position (contact point downward) for the low measuring force model and the long stroke model.

Dial Indicator

SERIES 2 — Standard Type, 0.01mm Resolution

Series 2 dial indicators are Mitutoyo's most popular, and have the widest application.

FEATURES

- Standard 0.01mm graduation dial gauges having a bezel with an outside diameter of 57mm. All types come with limit pins and a bezel clamp as standard.
- The bezel clamp and lifting lever (optional) can be attached to either the right or left side. These parts can be easily installed and removed without tools.
- Secured adhesion between the bezel and crystal as well as the use of an O-ring ensure countermeasures against water and oil permeation via the front face.
- The stem spindle is made of high-strength quench-hardened stainless steel which resists strenuous use.
- A carbide contact point is used.
- The crown gear uses stainless steel that is resistant to wear and deformation.
- Application of a hard coating on the surface of the crystal makes the gauge highly scratch- and chemical-resistant.



(Refer to page IX for details.)



2046S



2046S-60



2046S
2046SH
2046S-09
2046S-15
2046S-80
2046SLB

2046SY



2046S-60
2046S-69

2047S



2902S



2310S-10





Shockproof type



Waterproof type



Long stem type



Jeweled bearing type



w/ coaxial revolution counter



Reverse reading type

FEATURES

Metric

Order No.		Shockproof	Waterproof	Long stem	Jeweled bearing	Coaxial counter	Reverse reading
w/ lug	Flat-back						
2044S	2044SB	—	—	—	—	—	—
2044S-09	2044SB-09	✓	—	—	—	—	—
2044S-60	2044SB-60	—	✓	—	—	—	—
2045S	2045SB	—	—	—	—	—	—
2046S	2046SB	—	—	—	—	—	—
2046SY	2046SYB	—	—	—	—	—	—
2046SH	2046SHB	—	—	—	—	—	—
—	2046SLB	—	—	✓	—	—	—
2046S-09	2046SB-09	✓	—	—	—	—	—
2046S-60	2046SB-60	—	✓	—	—	—	—
2046S-69	2046SB-69	✓	✓	—	—	—	—
2046S-15	2046SB-15	—	—	—	✓	—	—
2310S-10	2310SB-10	—	—	—	✓	✓	—
2902S	2902SB	—	—	—	—	—	✓
2047S	2047SB	—	—	—	—	—	—

Optional Accessories

- : Backs (See page F-40.)
- : Contact points (See page F-36.)



2044S
2044S-60
2044S-09

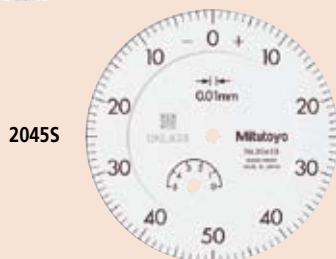

2045S

SPECIFICATIONS

Metric

ISO/JIS type

Graduation	Order No.		Range (range/rev)	Accuracy				Repeat-ability	Dial reading	Measuring force
	w/ lug	Flat-back		Overall	Retrace	1/10 Rev	1 Rev			
0.01mm	2044S	2044SB	5mm (1mm)	±12μm	5μm	8μm	±10μm	5μm	0-100	1.4N or less
0.01mm	2044S-09	2044SB-09	5mm (1mm)	±13μm	5μm	8μm	±10μm	5μm	0-100	1.4N or less
0.01mm	2044S-60	2044SB-60	5mm (1mm)	±12μm	5μm	8μm	±10μm	5μm	0-100	2.5N or less
0.01mm	2045S	2045SB	5mm (1mm)	±12μm	5μm	8μm	±10μm	5μm	0-50-0	1.4N or less
0.01mm	2046S	2046SB	10mm (1mm)	±13μm	5μm	8μm	±10μm	5μm	0-100	1.4N or less
0.01mm	2046SY	2046SYB	10mm (1mm)	±13μm	5μm	8μm	±10μm	5μm	0-100	1.4N or less
0.01mm	2046SH	2046SHB	10mm (1mm)	±8μm	4μm	5μm	±7μm	4μm	0-100	1.4N or less
0.01mm	—	2046SLB	10mm (1mm)	±13μm	5μm	8μm	±10μm	5μm	0-100	1.4N or less
0.01mm	2046S-09	2046SB-09	10mm (1mm)	±15μm	5μm	8μm	±10μm	5μm	0-100	1.4N or less
0.01mm	2046S-60	2046SB-60	10mm (1mm)	±13μm	5μm	8μm	±10μm	5μm	0-100	2.5N or less
0.01mm	2046S-69	2046SB-69	10mm (1mm)	±15μm	5μm	8μm	±10μm	5μm	0-100	2.5N or less
0.01mm	2046S-15	2046SB-15	10mm (1mm)	±13μm	5μm	8μm	±10μm	5μm	0-100	0.8N or less*
0.01mm	2310S-10	2310SB-10	10mm (1mm)	±15μm	5μm	8μm	±10μm	5μm	0-100	1.4N or less
0.01mm	2902S	2902SB	10mm (1mm)	±13μm	5μm	8μm	±10μm	5μm	100-0	1.4N or less
0.01mm	2047S	2047SB	10mm (1mm)	±13μm	5μm	8μm	±10μm	5μm	0-50-0	1.4N or less

*Use in a vertical position only (contact point downward).

DIMENSIONS

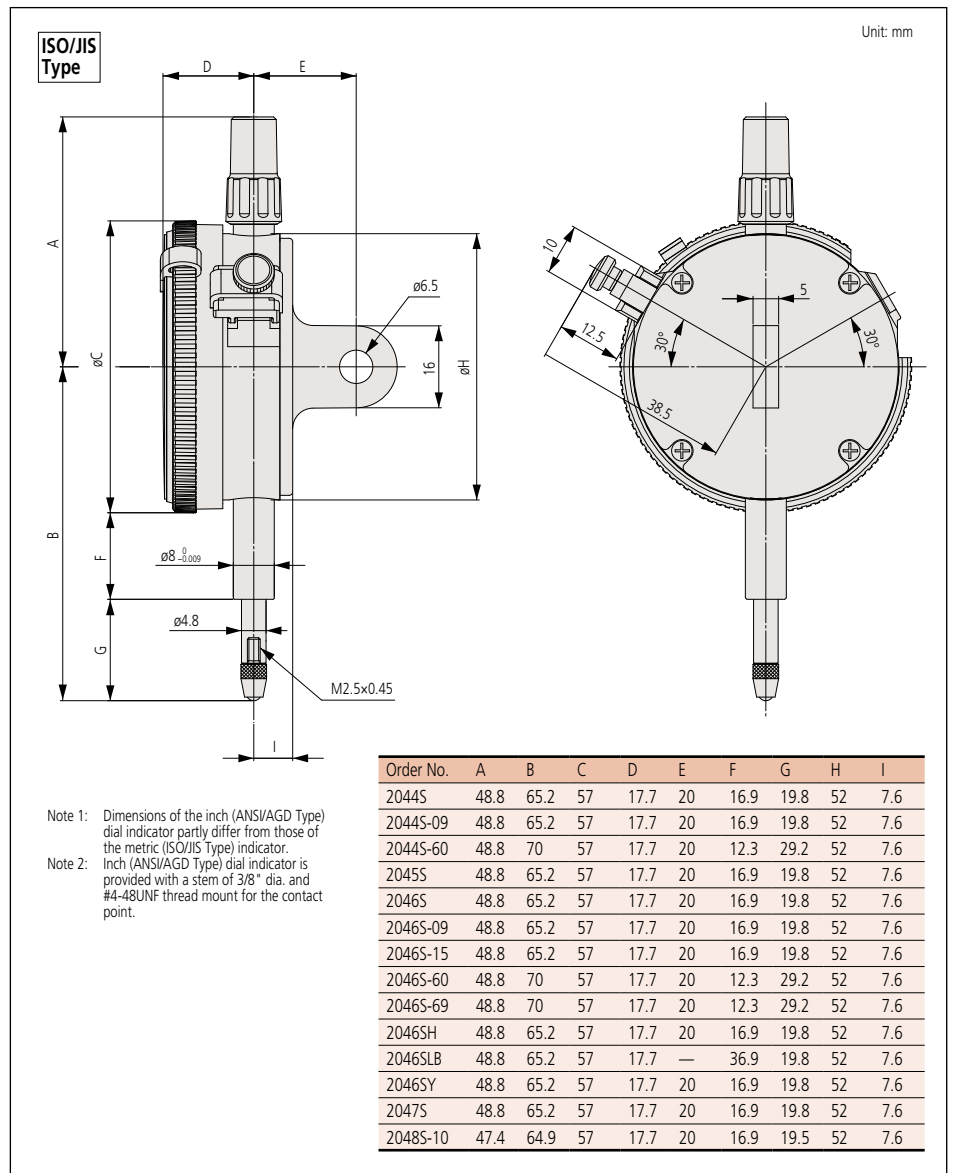

Dial Indicator

SERIES 2 — Standard Type, 0.001mm Resolution

FEATURES

- Standard 0.01mm graduation dial gauges having a bezel with an outside diameter of $\varnothing 57\text{mm}$. All types come with limit pins and a bezel clamp.
- The outer clamp and lifting lever (optional) can be attached to either the right or left side. These parts can be easily installed and removed without tools.
- Secure adhesion between the bezel and crystal as well as the use of an O-ring ensure prevention of water and oil ingress via the front face.
- The spindle is made of high-strength quench-hardened stainless steel which resists arduous use.
- A carbide contact point is used.
- The crown gear uses stainless steel that is resistant to wear and deformation.
- Application of a hard coating on the surface of the crystal makes the gauge highly scratch- and chemical-resistant.
- A special alloy is used for the sector gears to provide improved wear resistance.
- The indicator uses jeweled bearings, providing excellent indication sensitivity and durability.



2109S-10



2110S-10



2119S-10



(Refer to page IX for details.)



2109S-10
2109SH-10
2109S-70
2109SLB-10



2110S-10
2110S-70

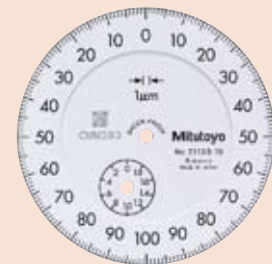

2113S-10

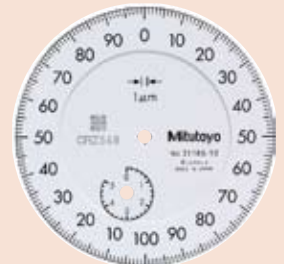

2118S-10

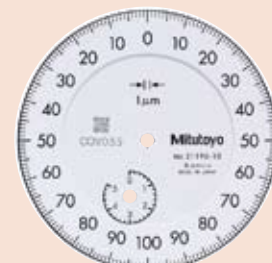

2119S-10



2124S-10



Shockproof type



Waterproof type



Long stem type



Jeweled bearing type



Double scale spacing type

FEATURES

Metric

Order No.		Shockproof type	Waterproof type	Long stem type	Jeweled bearing type	Double scale spacing type	—
w/ lug	Flat-back						
2124S-10	2124SB-10	—	—	—	✓	—	—
2110S-10	2110SB-10	✓	—	—	✓	✓	—
2110S-70	2110SB-70	✓	✓	—	✓	✓	—
2109S-10	2109SB-10	✓	—	—	✓	—	—
2109SH-10	2109SHB-10	✓	—	—	✓	—	—
—	2109SLB-10	✓	—	✓	✓	—	—
2109S-70	2109SB-70	✓	✓	—	✓	—	—
2113S-10	2113SB-10	✓	—	—	✓	—	—
2118S-10	2118SB-10	—	—	—	✓	—	—
2119S-10	2119SB-10	—	—	—	✓	—	—

Optional Accessories

- : Backs (See page F-40.)
- : Contact points (See page F-36.)

SPECIFICATIONS

Metric

ISO/JIS type

Graduation	Order No.		Range (range/rev)	Accuracy				Repeat-ability	Dial reading	Measuring force
	w/ lug	Flat-back		Overall	Retrace	1/10 Rev	1 Rev			
0.005mm	2124S-10	2124SB-10	5mm (0.5mm)	±12μm	5μm	7μm	±9μm	3μm	0-50	1.5N or less
0.001mm	2110S-10	2110SB-10	1mm (0.1mm)	±5μm	3μm	2.5μm	±4μm	0.5μm	0-100	1.5N or less
0.001mm	2110S-70	2110SB-70	1mm (0.1mm)	±5μm	3μm	2.5μm	±4μm	0.5μm	0-100	2.0N or less
0.001mm	2109S-10	2109SB-10	1mm (0.2mm)	±5μm	3μm	2.5μm	±4μm	0.5μm	0-100-0	1.5N or less
0.001mm	2109SH-10	2109SHB-10	1mm (0.2mm)	±3μm	2μm	2μm	±3μm	0.5μm	0-100-0	1.5N or less
0.001mm	—	2109SLB-10	1mm (0.2mm)	±5μm	3μm	2.5μm	±4μm	0.5μm	0-100-0	1.5N or less
0.001mm	2109S-70	2109SB-70	1mm (0.2mm)	±5μm	3μm	2.5μm	±4μm	0.5μm	0-100-0	2.0N or less
0.001mm	2113S-10	2113SB-10	2mm (0.2mm)	±7μm	3μm	4μm	±6μm	0.5μm	0-100-0	1.5N or less
0.001mm	2118S-10	2118SB-10	5mm (0.2mm)	±10μm	4μm	5μm	±7μm	1μm	0-100-100	1.5N or less
0.001mm	2119S-10	2119SB-10	5mm (0.2mm)	±10μm	4μm	5μm	±7μm	1μm	0-100-0	1.5N or less

DIMENSIONS

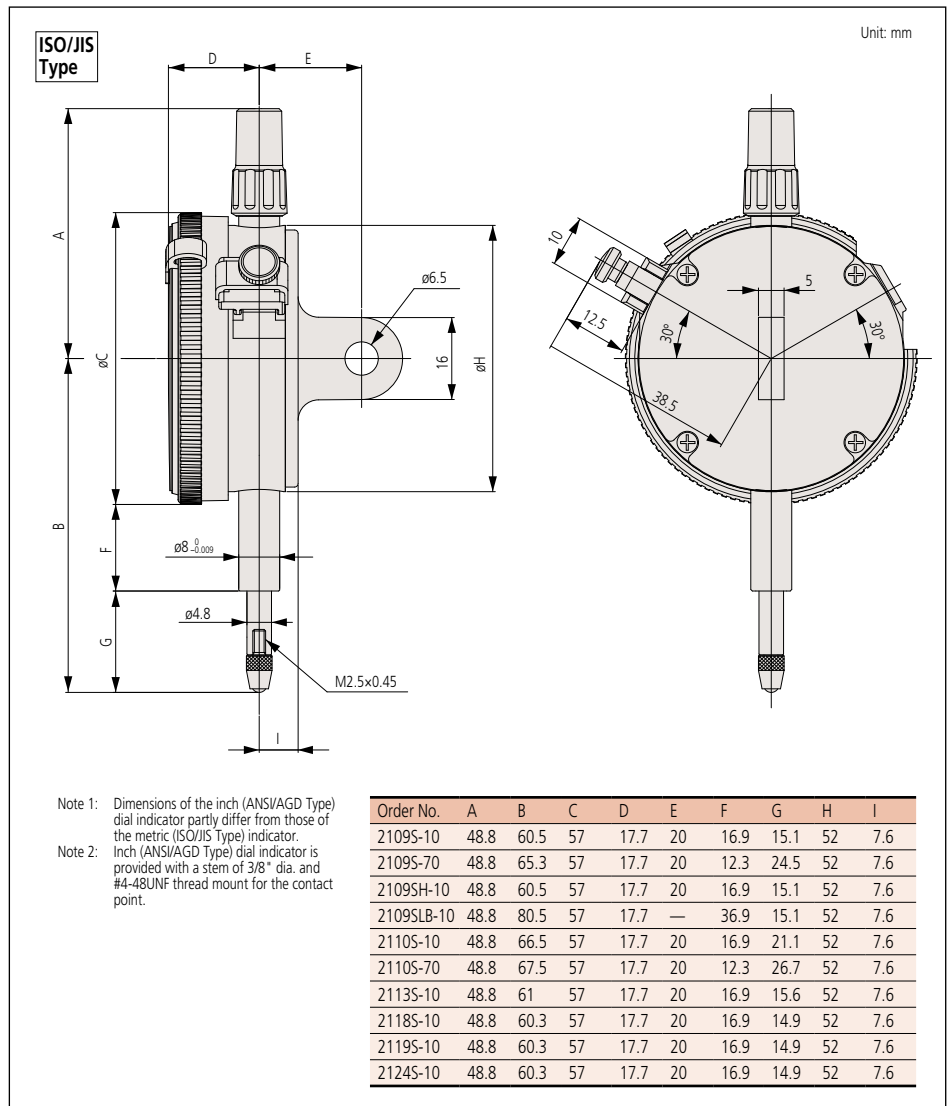

Dial Indicator

SERIES 2 — Standard Type, Inch Reading

SPECIFICATIONS

Graduation	Order No.		Range (range/rev)	Accuracy		Repeat-ability	Dial reading	Measuring force
	w/ lug	Flat-back		First 1 Rev / 2.5 Rev / 10 Rev	Retrace			
.001"	2780S	2780SB	.125" (.05")	±.001" / ±.001" / —	.0002"	±.0002"	±0-50	1.8N or less
.001"	2781S	2781SB	.125" (.05")	±.001" / ±.001" / —	.0002"	±.0002"	0-25-0	1.8N or less
.001"	2410S	2410SB	.25" (.1")	±.001" / ±.001" / —	.0002"	±.0002"	±0-100	1.8N or less
.001"	2410S-10	2410SB-10	.25" (.1")	±.001" / ±.001" / —	.0002"	±.0002"	±0-100	1.8N or less
.001"	2410S-60	2410SB-60	.25" (.1")	±.001" / ±.001" / —	.0002"	±.0002"	0-100	2.5N or less
.001"	2411S	2411SB	.25" (.1")	±.001" / ±.001" / —	.0002"	±.0002"	0-50-0	1.8N or less
.001"	2411S-10	2411SB-10	.25" (.1")	±.001" / ±.001" / —	.0002"	±.0002"	0-50-0	1.8N or less
.001"	2414S	2414SB	.5" (.1")	±.001" / ±.001" / ±.001"	.0002"	±.0002"	±0-100	1.8N or less
.001"	2414S-10	2414SB-10	.5" (.1")	±.001" / ±.001" / ±.001"	.0002"	±.0002"	±0-100	1.8N or less
.001"	2414S-60	2414SB-60	.5" (.1")	±.001" / ±.001" / ±.001"	.0002"	±.0002"	±0-100	2.5N or less
.001"	2415S	2415SB	.5" (.1")	±.001" / ±.001" / ±.001"	.0002"	±.0002"	0-50-0	1.8N or less
.001"	2415S-10	2415SB-10	.5" (.1")	±.001" / ±.001" / ±.001"	.0002"	±.0002"	0-50-0	1.8N or less
.001"	2415S-60	2415SB-60	.5" (.1")	±.001" / ±.001" / ±.001"	.0002"	±.0002"	0-50-0	2.5N or less
.001"	2914S	2914SB	.5" (.1")	±.001" / ±.001" / ±.001"	.0002"	±.0002"	100-0	1.8N or less
.0005"	2506S	2506SB	.125" (.05")	±.0005" / ±.0005" / —	.00016"	±.0001"	±0-50	1.8N or less
.0005"	2507S	2507SB	.125" (.05")	±.0005" / ±.0005" / —	.00016"	±.0001"	0-25-0	1.8N or less
.0005"	2514S	2514SB	.5" (.05")	±.0005" / ±.0005" / ±.0015"	.00016"	±.0001"	±0-50	1.8N or less
.0005"	2514S-60	2514SB-60	.5" (.05")	±.0005" / ±.0005" / ±.0015"	.00016"	±.0001"	±0-50	2.5N or less
.0005"	2570S-10	2570SB-10	.075" (.03")	±.0005" / ±.0005" / —	.00016"	±.0001"	0-30	1.8N or less
.0005"	2571S-10	2571SB-10	.075" (.03")	±.0005" / ±.0005" / —	.00016"	±.0001"	0-15-0	1.8N or less
.0005"	2576S-70	2576SB-70	.3" (.03")	±.0005" / ±.0005" / ±.001"	.00016"	±.0001"	0-30	2.5N or less
.0005"	2670S	2670SB	.1" (.04")	±.0005" / ±.0005" / —	.00016"	±.0001"	0-40	1.8N or less
.0005"	2671S	2671SB	.1" (.04")	±.0005" / ±.0005" / —	.00016"	±.0001"	0-20-0	1.8N or less
.0005"	2675S	2675SB	.4" (.04")	±.0005" / ±.0005" / ±.0015"	.00016"	±.0001"	0-20-0	1.8N or less
.0005"	2922S	2922SB	.125" (.05")	±.0005" / ±.0005" / —	.00016"	±.0001"	0-25-0	1.8N or less
.00025"	2470S-10	2470SB-10	.05" (.02")	±.00025" / ±.00025" / —	.000125"	±.0001"	0-20	1.8N or less
.00025"	2471S-10	2471SB-10	.05" (.02")	±.00025" / ±.00025" / —	.000125"	±.0001"	0-10-0	1.8N or less
.00025"	2476S-70	2476SB-70	.2" (.02")	±.00025" / ±.00025" / ±.0005"	.000125"	±.0001"	0-20	2.5N or less
.0001"	2356S-10	2356SB-10	.25" (.01")	±.0002" / ±.0002" / ±.0003"	.0001"	±.00003"	0-10	2.0N or less
.0001"	2358S-10	2358SB-10	.5" (.01")	±.0002" / ±.0002" / ±.0003"	.00015"	±.00003"	0-10	2.0N or less
.0001"	2802S-10	2802SB-10	.025" (.01")	±.0001" / ±.0001" / —	.0001"	±.00003"	0-10	2.0N or less
.0001"	2802S-70	2802SB-70	.025" (.01")	±.0001" / ±.0001" / —	.0001"	±.00003"	0-10	2.5N or less
.0001"	2803S-10	2803SB-10	.025" (.01")	±.0001" / ±.0001" / —	.0001"	±.00003"	0-5-0	2.0N or less
.0001"	2803S-70	2803SB-70	.025" (.01")	±.0001" / ±.0001" / —	.0001"	±.00003"	0-5-0	2.5N or less
.0001"	2804S-10	2804SB-10	.05" (.01")	±.0001" / ±.0001" / ±.0002"	.0001"	±.00003"	0-10	2.0N or less
.0001"	2805S-10	2805SB-10	.05" (.01")	±.0001" / ±.0001" / ±.0002"	.0001"	±.00003"	0-5-0	2.0N or less
.0001"	2806S-10	2806SB-10	.1" (.01")	±.0001" / ±.0001" / ±.0003"	.0001"	±.00003"	0-10	2.0N or less
.0001"	2806S-70	2806SB-70	.1" (.01")	±.0001" / ±.0001" / ±.0003"	.0001"	±.00003"	0-10	2.5N or less
.0001"	2905S-10	2905SB-10	.05" (.01")	±.0001" / ±.0001" / ±.0002"	.0001"	±.00003"	10-0	2.0N or less
.0001"	2923S-10	2923SB-10	.05" (.01")	±.0001" / ±.0001" / ±.0002"	.0001"	±.00003"	0-5-0	2.0N or less
.0001"	2937S-10	2937SB-10	.02" (.008")	±.0001" / ±.0001" / —	.0001"	±.00003"	0-4-0	2.0N or less
.0001"	2938S-10	2938SB-10	.02" (.008")	±.0001" / ±.0001" / —	.0001"	±.00003"	0-8	2.0N or less

ANSI/AGD type

FEATURES

Order No.	w/ lug	Flat-back	Inch					
							—	—
2780S	2780SB	—	—	—	—	—	—	—
2781S	2781SB	—	—	—	—	—	—	—
2410S	2410SB	—	—	—	—	—	—	—
2410S-10	2410SB-10	—	—	—	—	✓	—	—
2410S-60	2410SB-60	—	✓	—	—	—	—	—
2411S	2411SB	—	—	—	—	—	—	—
2411S-10	2411SB-10	—	—	—	—	✓	—	—
2414S	2414SB	—	—	—	—	—	—	—
2414S-10	2414SB-10	—	—	—	—	✓	—	—
2414S-60	2414SB-60	—	✓	—	—	—	—	—
2415S	2415SB	—	—	—	—	—	—	—
2415S-10	2415SB-10	—	—	—	—	✓	—	—
2415S-60	2415SB-60	—	✓	—	—	—	—	—
2914S	2914SB	—	—	✓	—	—	—	—
2506S	2506SB	—	—	—	—	—	—	—
2507S	2507SB	—	—	—	—	—	—	—
2514S	2514SB	—	—	—	—	—	—	—
2514S-60	2514SB-60	—	✓	—	—	—	—	—
2570S-10	2570SB-10	—	—	—	✓	—	—	—
2571S-10	2571SB-10	—	—	—	✓	—	—	—
2576S-70	2576SB-70	—	✓	—	✓	—	—	—
2670S	2670SB	—	—	—	—	—	—	—
2671S	2671SB	—	—	—	—	—	—	—
2675S	2675SB	—	—	—	—	—	—	—
2922S	2922SB	—	—	—	—	—	—	—
2470S-10	2470SB-10	—	—	—	—	✓	—	—
2471S-10	2471SB-10	—	—	—	—	✓	—	—
2476S-70	2476SB-70	—	✓	—	✓	—	—	—
2356S-10	2356SB-10	—	—	—	✓	—	—	—
2358S-10	2358SB-10	—	—	—	✓	—	—	—
2802S-10	2802SB-10	✓	—	—	✓	—	—	—
2802S-70	2802SB-70	✓	✓	—	✓	—	—	—
2803S-10	2803SB-10	✓	—	—	✓	—	—	—
2803S-70	2803SB-70	✓	✓	—	✓	—	—	—
2804S-10	2804SB-10	✓	—	—	✓	—	—	—
2805S-10	2805SB-10	✓	—	—	✓	—	—	—
2806S-10	2806SB-10	✓	—	—	✓	—	—	—
2806S-70	2806SB-70	✓	✓	—	✓	—	—	—
2905S-10	2905SB-10	✓	—	✓	✓	—	—	—
2923S-10	2923SB-10	✓	—	—	✓	—	—	—
2937S-10	2937SB-10	✓	—	—	✓	—	—	—
2938S-10	2938SB-10	✓	—	—	✓	—	—	—



(Refer to page IX for details.)

Optional Accessories

- : Backs (See page F-40.)
- : Contact points (See page F-36.)

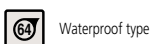

DIMENSIONS

ANSI/AGD
Type

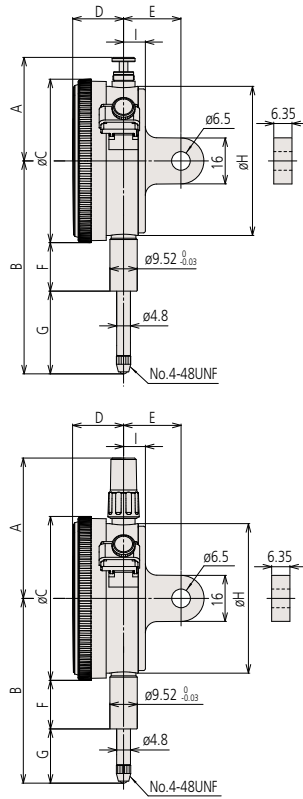

Unit: mm

Order No.	A	B	C	D	E	F	G	H	I
2780S	48.8	54.3	57	17.7	19	13.6	12.2	52	7.6
2781S	48.8	54.3	57	17.7	19	13.6	12.2	52	7.6
2410S	48.8	57.8	57	17.7	19	13.6	15.7	52	7.6
2410S-10	48.8	57.8	57	17.7	19	13.6	15.7	52	7.6
2410S-60	48.8	62.7	57	17.7	19	10.6	23.6	52	7.6
2411S	48.8	57.8	57	17.7	19	13.6	15.7	52	7.6
2411S-10	48.8	57.8	57	17.7	19	13.6	15.7	52	7.6
2414S	38.9	64.1	57	17.7	19	13.6	22	52	7.6
2414S-10	38.9	64.1	57	17.7	19	13.6	22	52	7.6
2414S-60	48.8	69	57	17.7	19	10.6	29.9	52	7.6
2415S	38.9	64.1	57	17.7	19	13.6	22	52	7.6
2415S-10	38.9	64.1	57	17.7	19	13.6	22	52	7.6
2415S-60	48.8	69	57	17.7	19	10.6	29.9	52	7.6
2914S	38.9	64.1	57	17.7	19	13.6	22	52	7.6
2506S	48.8	54.3	57	17.7	19	13.6	12.2	52	7.6
2507S	48.8	54.3	57	17.7	19	13.6	12.2	52	7.6
2514S	38.9	64.1	57	17.7	19	13.6	22	52	7.6
2514S-60	48.8	69	57	17.7	19	10.6	29.9	52	7.6
2570S-10	48.8	52.9	57	17.7	19	13.6	10.8	52	7.6
2571S-10	48.8	52.9	57	17.7	19	13.6	10.8	52	7.6
2576S-70	48.8	63.5	57	17.7	19	10.6	24.4	52	7.6
2670S	48.8	53.6	57	17.7	19	13.6	11.5	52	7.6
2671S	48.8	53.6	57	17.7	19	13.6	11.5	52	7.6
2675S	48.8	61.2	57	17.7	19	13.6	19.1	52	7.6
2922S	48.8	54.3	57	17.7	19	13.6	12.2	52	7.6
2470S-10	48.8	52.2	57	17.7	19	13.6	10.1	52	7.6
2471S-10	48.8	52.2	57	17.7	19	13.6	10.1	52	7.6
2476S-70	48.8	60.9	57	17.7	19	10.6	21.8	52	7.6
2356S-10	48.8	57.2	57	17.7	19	13.6	15.1	52	7.6
2358S-10	38.9	63.6	57	17.7	19	13.6	21.5	52	7.6
2802S-10	48.8	51.4	57	17.7	19	13.6	9.3	52	7.6
2802S-70	48.8	56.3	57	17.7	19	10.6	17.2	52	7.6
2803S-10	48.8	51.4	57	17.7	19	13.6	9.3	52	7.6
2803S-70	48.8	56.3	57	17.7	19	10.6	17.2	52	7.6
2804S-10	48.8	51.7	57	17.7	19	13.6	9.6	52	7.6
2805S-10	48.8	51.7	57	17.7	19	13.6	9.6	52	7.6
2806S-10	48.8	53.4	57	17.7	19	13.6	11.3	52	7.6
2806S-70	48.8	58.3	57	17.7	19	10.6	19.2	52	7.6
2905S-10	48.8	51.7	57	17.7	19	13.6	9.6	52	7.6
2923S-10	48.8	51.7	57	17.7	19	13.6	9.6	52	7.6
2937S-10	48.8	51.3	57	17.7	19	13.6	9.2	52	7.6
2938S-10	48.8	51.3	57	17.7	19	13.6	9.2	52	7.6

Special Dial Indicators

SERIES 2



Adjustable hand



20485-10

Adjustable hand dial gauge

The hand position can be adjusted independently of the position of the spindle by rotating the top knob.



Peak hold



20465-80

Peak hold type dial gauge

A mechanism holds the pointer and the spindle at the position of maximum depression and hence displays the maximum value.



Double-face type



2940S

Double-face type dial gauge

The displacement of the spindle can be read from either the front or rear face.

SPECIFICATIONS

Metric			ISO/JIS type							
Graduation	Order No.		Range (range/rev)	Accuracy				Repeat-ability	Dial reading	Measuring force
	w/ lug	Flat-back		Overall	Retrace	1/10 Rev	1 Rev			
0.01mm	20485-10	20485B-10	10mm (1mm)	±15µm	5µm	8µm	±10µm	5µm	0-100	1.4N or less
0.01mm	20465-80	20465B-80	10mm (1mm)	±15µm	—	8µm	±10µm	—	0-100	5.0N or less
0.01mm	2940S	—	10mm (1mm)	±15µm	5µm	8µm	±10µm	5µm	0-100	3.0N or less

Metric			ANSI/AGD type							
Graduation	Order No.		Range (range/rev)	Accuracy			Repeat-ability	Dial reading	Measuring force	
	w/ lug	Flat-back		First 1 Rev / 2.5 Rev / 10 Rev	Retrace	—				
0.01mm	20485-11	20485B-11	10mm (1mm)	±10µm / ±10µm / ±13µm	—	3µm	±3µm	±0-100	1.4N or less	

Inch			ANSI/AGD type							
Graduation	Order No.		Range (range/rev)	Accuracy			Repeat-ability	Dial reading	Measuring force	
	w/ lug	Flat-back		First 1 Rev / 2.5 Rev / 10 Rev	Retrace	—				
.001"	29155-10	29155B-10	.5" (.1")	±.001" / ±.001" / ±.001	—	.0002	±.0002	0-100	1.8N or less	
.001"	29185-10	29185B-10	.5" (.1")	±.001" / ±.001" / ±.001	—	.0002	±.0002	0-50-0	1.8N or less	



(Refer to page IX for details.)

FEATURES

Metric			Features					
Order No.	w/ lug	Flat-back	Adjustable hand	Peak hold	Double-face	—	—	—
20485-10	20485B-10	20485B-10	✓	—	—	—	—	—
20465-80	20465B-80	20465B-80	—	✓	—	—	—	—
2940S	—	—	—	—	✓	—	—	—

Metric			Features					
Order No.	w/ lug	Flat-back	Adjustable hand	Peak hold	Double-face	—	—	—
20485-11	20485B-11	20485B-11	✓	—	—	—	—	—

Inch			Features					
Order No.	w/ lug	Flat-back	Adjustable hand	Peak hold	Double-face	—	—	—
29155-10	29155B-10	29155B-10	✓	—	—	—	—	—
29185-10	29185B-10	29185B-10	✓	—	—	—	—	—

Optional Accessories

- : Backs (See page F-40.)
- : Contact points (See page F-36.)

DIMENSIONS

ISO/JIS
Type

Unit: mm

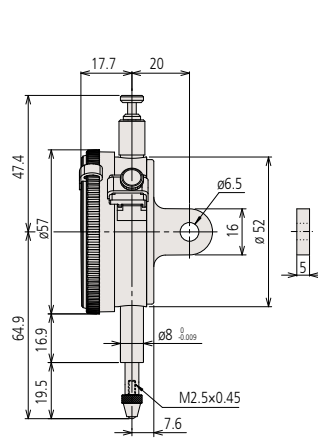

2048S-10

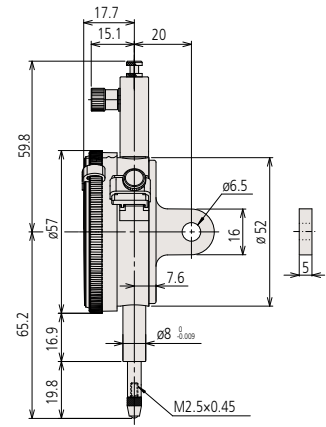

2046S-80

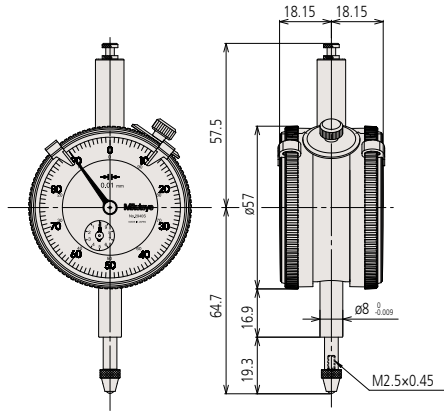

2940S

Dial Indicator

SERIES 2 — Standard One Revolution Type for Error-free Reading

Unlike many other dial indicators, the one-revolution dial indicator literally shows the entire spindle travel or range as one sweep of the hand, eliminating the possibility of reading errors due to miscounting multiple revolutions. With one-revolution dial indicators, "within tolerance" and "out-of-tolerance" can never be misinterpreted.

FEATURES

- A unique shock-proof mechanism is incorporated, providing improved immunity to shock due to sudden spindle retraction caused by high impact.

- The crystal is hard coated for durability and scratch resistance.
- Approximately 40% lighter than the conventional dial indicator.
- Provided with an improved resistance to shop floor contaminants such as water and dust.
- Due to the spindle bushing being offset from the stem, spindle movement will not be hindered or jammed when clamping along the stem.
- A pair of limit hands are provided for quick and easy tolerance judgment (GO/±NG).



2971

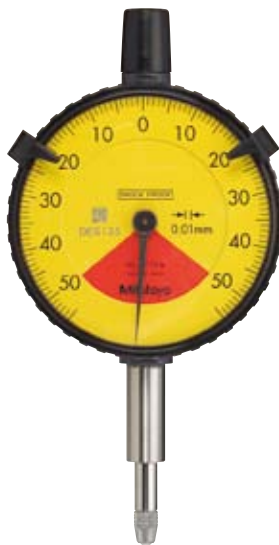

2972

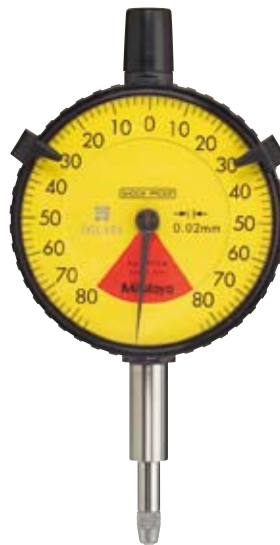

2973

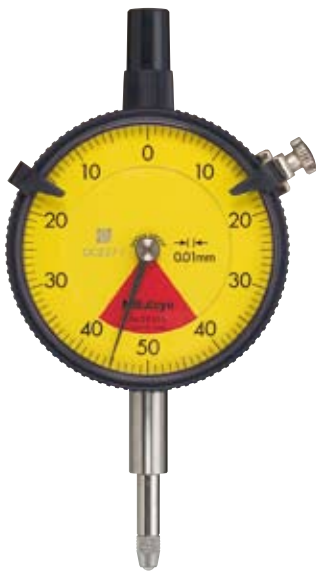

29295



29005-10



2990



(Refer to page IX for details.)



2971



2972

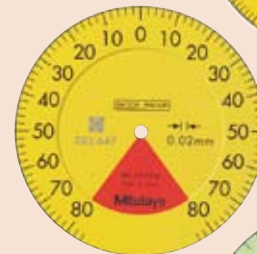

2973



29285



29295
29295-60
29295-62

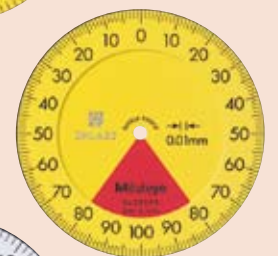

29595

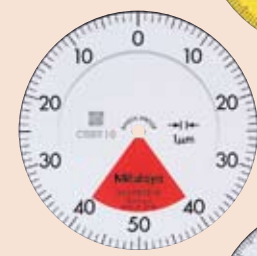

29005-10
29005-70
29005-72

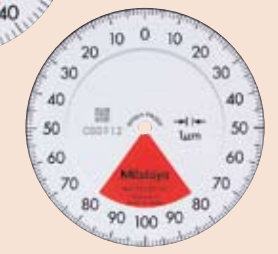

29015-10



FEATURES

Metric

Order No.	w/ lug	Flat-back	Shockproof	Waterproof	Dustproof	Jeweled bearing		
2928S	2928SB	—	—	—	—	—	—	—
2929S	2929SB	—	✓	—	—	—	—	—
2929S-60	2929SB-60	—	—	—	—	—	—	—
2929S-62	2929SB-62	—	—	—	—	—	—	—
2959S	2959SB	—	—	—	—	—	—	—
2900S-10	2900SB-10	—	✓	—	—	—	—	—
2900S-70	2900SB-70	—	—	✓	—	—	—	—
2900S-72	2900SB-72	✓	—	—	—	—	—	—
2901S-10	2901SB-10	✓	—	—	—	—	—	—
—	2973	—	✓	—	—	—	—	—
—	2971	—	✓	—	—	—	—	—
—	2972	—	✓	—	—	—	—	—
2990*	—	—	—	—	—	—	—	—
—	2960F*	—	—	—	—	—	—	—

Inch

Order No.	w/ lug	Flat-back	Shockproof	Waterproof	Dustproof	Jeweled bearing		
2908S	2908SB	—	—	—	—	—	—	—
2908S-62	2908SB-62	—	✓	—	—	—	—	—
2909S-62	2909SB-62	—	✓	—	—	—	—	—
2910S-10	2910SB-10	—	✓	—	—	—	—	—
2910S-72	2910SB-72	—	—	—	—	—	—	—
—	2978	—	—	—	—	—	—	—
—	2976	—	✓	—	—	—	—	—
—	2977	—	—	—	—	—	—	—
—	2991*	—	✓	—	—	—	—	—

Optional Accessories

- : Backs (See page F-40.)
- : Contact points (See page F-36.)

SPECIFICATIONS

Metric

ISO/JIS type

Graduation	Order No.		Range (range/rev)	Accuracy				Repeat-ability	Dial reading	Measuring force
	w/ lug	Flat-back		Overall	Retrace	1/10 Rev	1 Rev			
0.1mm	2928S	2928SB	4mm / 10mm	±40μm	20μm	20μm	—	20μm	2-0-2	1.4N or less
0.01mm	2929S	2929SB	0.8mm / 1mm	±9μm	5μm	6μm	—	5μm	40-0-40	1.4N or less
0.01mm	2929S-60	2929SB-60	0.8mm / 1mm	±9μm	5μm	6μm	—	5μm	40-0-40	2.0N or less
0.01mm	2929S-62	2929SB-62	0.8mm / 1mm	±9μm	5μm	6μm	—	5μm	40-0-40	2.0N or less
0.01mm	2959S	2959SB	1.6mm / 2mm	±13μm	6μm	8μm	—	5μm	80-0-80	1.4N or less
0.001mm	2900S-10	2900SB-10	0.08mm / 0.1mm	±3μm	2.5μm	2.5μm	—	0.5μm	40-0-40	1.4N or less
0.001mm	2900S-70	2900SB-70	0.08mm / 0.1mm	±3μm	2.5μm	2.5μm	—	0.5μm	40-0-40	2.0N or less
0.001mm	2900S-72	2900SB-72	0.08mm / 0.1mm	±3μm	2.5μm	2.5μm	—	0.5μm	40-0-40	2.0N or less
0.001mm	2901S-10	2901SB-10	0.16mm / 0.2mm	±4μm	3μm	3μm	—	0.5μm	80-0-80	1.4N or less
0.02mm	2973	—	1.6mm / 2mm	±16μm	6μm	8μm	—	5μm	80-0-80	1.4N or less
0.01mm	2971	—	0.5mm / 0.7mm	±10μm	5μm	7μm	—	5μm	25-0-25	1.4N or less
0.01mm	2972	—	1mm / 1.4mm	±12μm	5μm	7μm	—	5μm	50-0-50	1.4N or less
0.01mm	2990*	—	0.1mm / 0.14mm	±6.5μm	4μm	4μm	—	1μm	50-0-50	1.5N or less
0.001mm	2960F*	—	1mm / 1.27mm	±14μm	7μm	10μm	—	5μm	50-0-50	1.4N or less

*Back plunger type (see page 262.)

Inch

ANSI/AGD type

Graduation	Order No.		Range (range/rev)	Accuracy		Repeat-ability	Dial reading	Measuring force
	w/ lug	Flat-back		First 1 Rev / 2.5 Rev / 10 Rev	Retrace			
.001"	2908S	2908SB	.08" / .1"	±.001" / — / —	.0002"	±.0002"	40-0-40	1.8N or less
.001"	2908S-62	2908SB-62	.08" / .1"	±.001" / — / —	.0002"	±.0002"	40-0-40	2.5N or less
.0005"	2909S-62	2909SB-62	.04" / .05"	±.0005" / — / —	.00016"	±.0001"	20-0-20	2.5N or less
.0001"	2910S-10	2910SB-10	.008" / .01"	±.0001" / — / —	.0001"	±.00003"	4-0-4	1.8N or less
.0001"	2910S-72	2910SB-72	.008" / .01"	±.0001" / — / —	.0001"	±.00003"	4-0-4	2.5N or less
.001"	2978	—	.06" / .079"	±.001" / — / —	.0002"	±.0002"	30-0-30	1.4N or less
.0005"	2976	—	.02" / .028"	±.0005" / — / —	.00016"	±.0001"	10-0-10	1.4N or less
.0005"	2977	—	.04" / .055"	±.0005" / — / —	.00016"	±.0001"	20-0-20	1.4N or less
.0001"	2991*	—	.008" / .01"	±.0002" / — / —	.0001"	±.00005"	4-0-4	1.5N or less

*Back plunger type (see page 262.)

DIMENSIONS

Unit: mm

ANSI/AGD Type

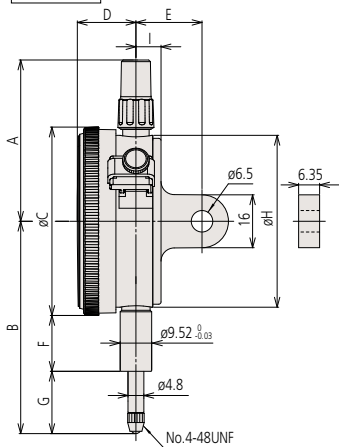

ISO/JIS Type

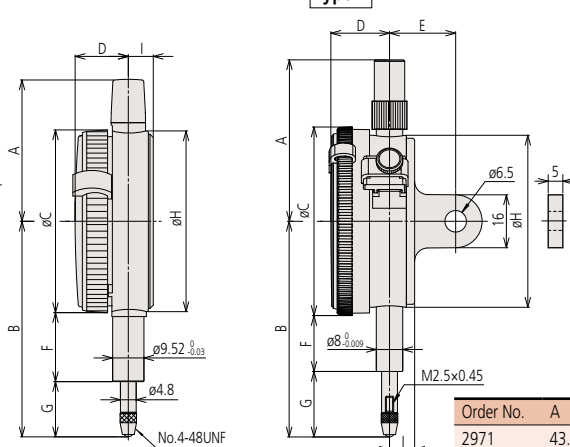

- Note 1: Dimensions of the inch (ANSI/AGD Type) dial indicator partly differ from those of the metric (ISO/JIS Type) indicator.
 Note 2: Inch (ANSI/AGD Type) dial indicator is provided with a stem of 3/8" dia. and #4-48UNF thread mount for the contact point.

Order No.	A	B	C	D	E	F	G	H	I
2908S	48.8	52.9	57	17.7	19	13.6	10.8	52	7.6
2908S-62	48.8	52.9	57	17.7	19	13.6	10.8	52	7.6
2909S-62	48.8	51.9	57	17.7	19	13.6	9.8	52	7.6
2910S-10	48.8	51.2	57	17.7	19	13.6	9.1	52	7.6
2910S-72	48.8	51.2	57	17.7	19	13.6	9.1	52	7.6
2976	43.2	64.7	55.6	16.2	—	21	15.9	55	7.6
2977	43.2	65	55.6	16.2	—	21	16.2	55	7.6
2978	43.2	65.3	55.6	16.2	—	21	16.5	55	7.6

Order No.	A	B	C	D	E	F	G	H	I
2971	43.2	65.6	55.6	16.2	—	21	16.8	55	7.6
2972	43.2	66.0	55.6	16.2	—	21	17.2	55	7.6
2973	43.2	66.3	55.6	16.2	—	21	17.5	55	7.6
2929S	48.8	65.2	57	17.7	20	12.3	29.2	52	7.6
2929S-62	48.8	65.2	57	17.7	20	16.9	19.8	52	7.6
2929S-60	48.8	70	57	17.7	20	12.3	29.2	52	7.6
2959S	48.8	65.2	57	17.7	20	16.9	19.8	52	7.6
2900S-10	48.8	66	57	17.7	20	16.9	20.6	52	7.6
2900S-72	48.8	66	57	17.7	20	16.9	20.6	52	7.6
2900S-70	48.8	67	57	17.7	20	12.3	26.2	52	7.6
2901S-10	48.8	66.1	57	17.7	20	16.9	20.7	52	7.6
2928S	48.8	65.2	57	17.7	20	16.9	19.8	52	7.6

Dial Indicator

SERIES 2 — Long Stroke Type



2050S



2330S-10



2052S



(Refer to page IX for details.)



2050S-60
2050S
2050S-19

2052S
2052S-19



2330S-10

2320S-10



2952S



Shockproof type



Waterproof type



w/ damper at lowest rest point



Jeweled bearing type



w/ coaxial revolution counter



Reverse reading type

FEATURES

Metric							
Order No.	Flat-back						
2050S	2050SB	—	—	✓	—	—	—
2050S-60	2050SB-60	—	✓	—	—	—	—
2050S-19	2050SB-19	✓	—	✓	✓	—	—
2320S-10	2320SB-10	—	—	✓	✓	✓	—
2052S	2052SB	—	—	✓	—	—	—
2052S-19	2052SB-19	✓	—	✓	✓	—	—
2330S-10	2330SB-10	—	—	✓	✓	✓	—
2952S	2952SB	—	—	✓	—	—	✓

Inch							
Order No.	Flat-back						
2204S	2204SB	—	—	—	—	—	—
2416S	2416SB	—	—	—	—	—	—
2416S-06	2416SB-06	—	—	—	—	—	—
2416S-10	2416SB-10	—	—	—	✓	—	—
2416S-60	2416SB-60	—	✓	—	—	—	—
2417S	2417SB	—	—	—	—	—	—
2424S-19	2424SB-19	✓	—	—	✓	—	✓
2776S	2776SB	—	—	—	—	—	—
2776S-60	2776SB-60	—	✓	—	—	—	—
2904S	2904SB	—	—	✓	—	—	—

Optional Accessories

- : Backs (See page F-40.)
- : Contact points (See page F-36.)

SPECIFICATIONS

Metric		ISO/JIS type									
Graduation	Order No.		Range (range/rev)	Accuracy				Repeat-ability	Dial reading	Measuring force	
	w/ lug	Flat-back		Overall	Retrace	1/10 Rev	1 Rev				
0.01mm	2050S	2050SB	20mm (1mm)	±20µm	7µm	10µm	±15µm	5µm	0-100	2.0N or less	
0.01mm	2050S-60	2050SB-60	20mm (1mm)	±20µm	7µm	10µm	±15µm	5µm	0-100	2.5N or less	
0.01mm	2050S-19	2050SB-19	20mm (1mm)	±20µm	7µm	10µm	±15µm	5µm	0-100	2.0N or less	
0.01mm	2320S-10	2320SB-10	20mm (1mm)	±20µm	7µm	10µm	±15µm	5µm	0-100	2.0N or less	
0.01mm	2052S	2052SB	30mm (1mm)	±25µm	7µm	14µm	±18µm	5µm	0-100	2.5N or less	
0.01mm	2052S-19	2052SB-19	30mm (1mm)	±25µm	7µm	14µm	±18µm	5µm	0-100	2.5N or less	
0.01mm	2330S-10	2330SB-10	30mm (1mm)	±25µm	7µm	14µm	±18µm	5µm	0-100	2.5N or less	
0.01mm	2952S	2952SB	30mm (1mm)	±25µm	7µm	14µm	±18µm	5µm	100-0	2.5N or less	

Inch		ANSI/AGD type									
Graduation	Order No.		Range (range/rev)	Accuracy		Repeat-ability	Dial reading	Measuring force			
	w/ lug	Flat-back		First 1 Rev / 2.5 Rev / 10 Rev	Retrace						
.01"	2204S	2204SB	1" (.1")	±.005" / — / —		±.002"	0-1000	1.8N or less			
.001"	2416S	2416SB	1" (.1")	±.001" / ±.001" / ±.002"		±.0002"	±0-100	1.8N or less			
.001"	2416S-06	2416SB-06	1" (.1")	±.001" / ±.001" / ±.002"		±.0002"	±0-100	1.8N or less			
.001"	2416S-10	2416SB-10	1" (.1")	±.001" / ±.001" / ±.002"		±.0002"	±0-100	1.8N or less			
.001"	2416S-60	2416SB-60	1" (.1")	±.001" / ±.001" / ±.002"		±.0002"	±0-100	2.5N or less			
.001"	2417S	2417SB	1" (.1")	±.001" / ±.001" / ±.002"		±.0002"	0-50-0	1.8N or less			
.001"	2424S-19	2424SB-19	2" (.1")	±.001" / ±.001" / ±.002"		±.00033"	±0-100	2.5N or less			
.0005"	2776S	2776SB	1" (.05")	±.0005" / ±.0005" / ±.0015"		±.0001"	±0-50	1.8N or less			
.0005"	2776S-60	2776SB-60	1" (.05")	±.0005" / ±.0005" / ±.0015"		±.0001"	±0-50	2.5N or less			
.001"	2904S	2904SB	1" (.1")	±.001" / ±.001" / ±.002"		±.0002"	100-0	1.8N or less			

DIMENSIONS

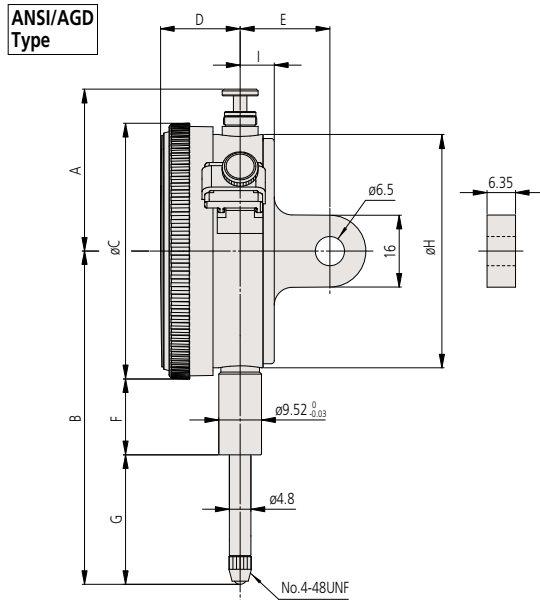

Order No.	A	B	C	D	E	F	G	H	I
2204S	40.2	76.8	57	17.7	19	13.6	34.7	52	7.6
2416S	38.9	76.8	57	17.7	19	13.6	34.7	52	7.6
2416S-06	38.9	76.8	57	17.7	19	13.6	34.7	52	7.6
2416S-10	38.9	76.8	57	17.7	19	13.6	34.7	52	7.6
2416S-60	66.8	87.2	57	17.7	19	10.6	48.1	52	7.6
2417S	38.9	76.8	57	17.7	19	13.6	34.7	52	7.6
2424S-19	118	142.5	57	17.7	20.9	54.3	59.7	52	9.5
2776S	38.9	76.8	57	17.7	19	13.6	34.7	52	7.6
2776S-60	66.8	87.2	57	17.7	19	10.6	48.1	52	7.6
2904S	38.9	76.8	57	17.7	19	13.6	34.7	52	7.6

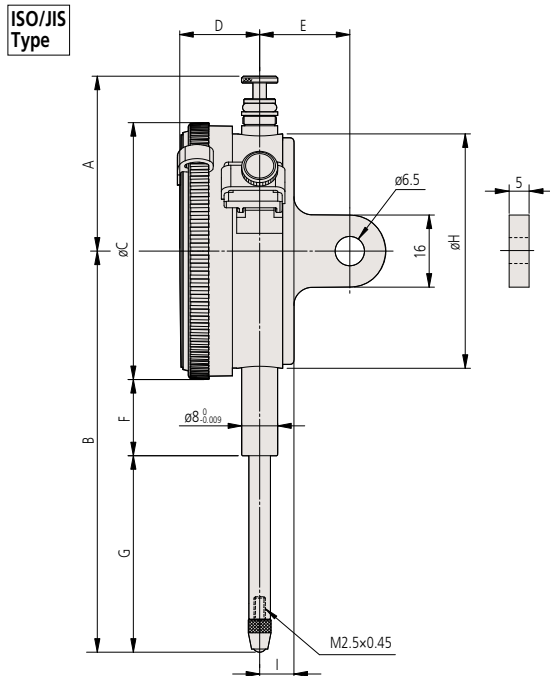

Order No.	A	B	C	D	E	F	G	H	I
2050S	38.8	75.2	57	17.7	20	16.9	29.8	52	7.6
2050S-60	59.8	87.2	57	17.7	20	12.3	46.4	52	7.6
2050S-19	38.8	75.2	57	17.7	20	16.9	29.8	52	7.6
2320S-10	38.8	75.2	57	17.7	20	16.9	29.8	52	7.6
2052S	38.8	88.7	57	17.7	20	16.9	43.3	52	7.6
2052S-19	38.8	88.7	57	17.7	20	16.9	43.3	52	7.6
2330S-10	38.8	88.7	57	17.7	20	16.9	43.3	52	7.6
2952S	38.8	88.7	57	17.7	20	16.9	43.3	52	7.6

Dial Indicator

SERIES 3, 4 — Large Dial Face and Long Stroke Type

- Dial gauges with a large-diameter dial face to ease reading.
- All types come with limit pins and a bezel clamp as standard.



(Refer to page IX for details.)

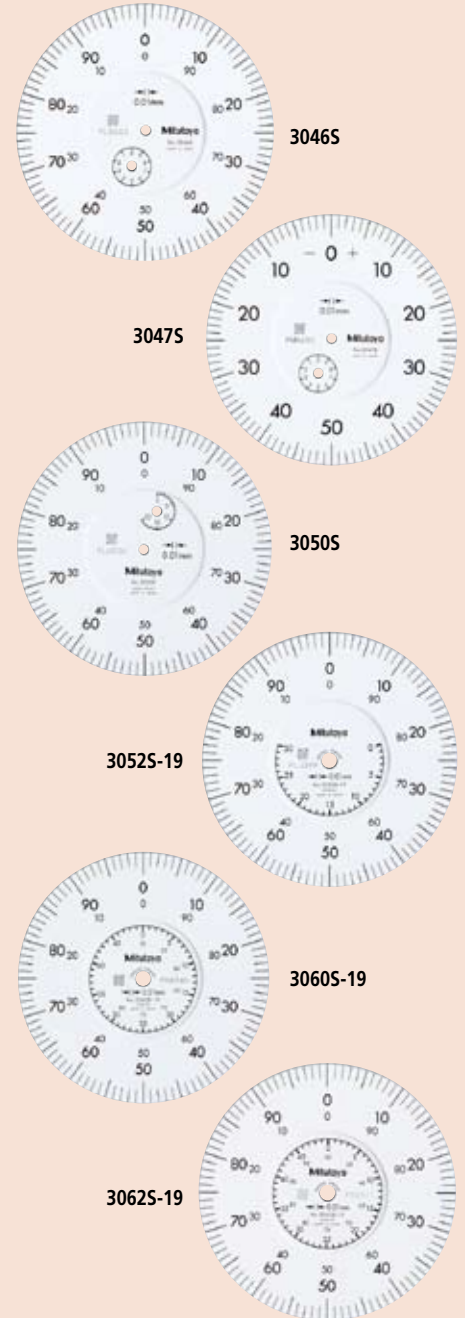

DIMENSIONS

ISO/JIS Type

Order No.	A	B	C	D
3046S	61.2	75.5	15.9	20.6
3047S	61.2	75.5	15.9	20.6
3050S	52.6	94	25.9	29.1
3052S-19	50.5	104.3	25.9	39.4
3058S-19	81.9	142.3	43.9	59.4
3060S-19	120.9	202.3	73.9	89.4
3062S-19	141.9	243.3	94.9	109.4
3109S-10	61.2	79.3	25.9	14.1

Unit: mm

Note 1: Dimensions of the inch (ANSI/AGD Type) dial indicator partly differ from those of the metric (ISO/JIS Type) indicator.
 Note 2: Inch (ANSI/AGD Type) dial indicator is provided with a stem of 3/8" dia. and #4-48UNF thread mount for the contact point.

F

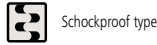

Shockproof type



w/ damper at lowest rest point



Jeweled bearing type



w/ coaxial revolution counter

FEATURES

Metric							
Order No.	w/ lug	Flat-back					
3046S	3046SB	—	—	—	—	—	—
3047S	3047SB	—	—	—	—	—	—
3050S	3050SB	—	✓	—	—	—	—
3052S-19	3052SB-19	✓	—	✓	✓	—	—
3058S-19	3058SB-19	✓	—	✓	✓	—	—
3060S-19*	3060SB-19*	✓	—	✓	✓	—	—
3062S-19*	3062SB-19*	✓	—	✓	✓	—	—
3109S-10	3109SB-10	✓	—	✓	—	—	—
4046S	4046SB	—	—	—	—	—	—

Metric							
Order No.	w/ lug	Flat-back					
3052S-11	3052SB-11	—	—	✓	✓	—	—
3058S-11	3058SB-11	—	—	✓	✓	—	—

Inch						
Order No.	w/ lug	Flat-back				
3414S	3414SB	—	—	—	—	—
3415S	3415SB	—	—	—	—	—
3416S	3416SB	—	—	—	—	—
3417S	3417SB	—	—	—	—	—
3424S-19	3424SB-19	✓	✓	✓	—	—
3426S-19	3426SB-19	✓	✓	✓	—	—
3428S-19	3428SB-19	✓	✓	✓	—	—
3570S-10	3570SB-10	—	✓	—	—	—
3571S-10	3571SB-10	—	✓	—	—	—
3802S-10	3802SB-10	✓	✓	—	—	—
3803S-10	3803SB-10	✓	✓	—	—	—
4410S	4410SB	—	—	—	—	—
4887S-19	4887SB-19	✓	✓	✓	—	—
4570S-10	4570SB-10	—	✓	—	—	—
4802S-10	4802SB-10	✓	✓	—	—	—
4803S-10	4803SB-10	✓	✓	—	—	—

Optional Accessory

—: Contact points (See page F-36.)

SPECIFICATIONS

Metric		ISO/JIS type								
Graduation	Order No.		Range (range/rev)	Accuracy				Repeatability	Dial reading	Measuring force
	w/ lug	Flat-back		Overall	Retrace	1/10 Rev	1 Rev			
0.01mm	3046S	3046SB	10mm (1mm)	±15µm	5µm	8µm	±10µm	5µm	0-100	1.4N or less
0.01mm	3047S	3047SB	10mm (1mm)	±15µm	5µm	8µm	±10µm	5µm	0-50-0	1.4N or less
0.01mm	3050S	3050SB	20mm (1mm)	±20µm	7µm	10µm	±15µm	5µm	0-100	2.0N or less
0.01mm	3052S-19	3052SB-19	30mm (1mm)	±25µm	7µm	14µm	±18µm	5µm	0-100	2.5N or less
0.01mm	3058S-19	3058SB-19	50mm (1mm)	±30µm	9µm	15µm	±20µm	5µm	0-100	3.0N or less
0.01mm	3060S-19*	3060SB-19*	80mm (1mm)	±45µm	11µm	—	—	6µm	0-100	3.0N or less
0.01mm	3062S-19*	3062SB-19*	100mm (1mm)	±50µm	15µm	—	—	6µm	0-100	3.2N or less
0.001mm	3109S-10	3109SB-10	1mm (0.2mm)	±6µm	4µm	3µm	±5µm	1µm	0-100-0	1.5N or less
0.01mm	4046S	4046SB	10mm (1mm)	±15µm	6µm	8µm	±10µm	5µm	0-100	1.4N or less

*Use in a vertical position only.

Metric		ANSI/AGD type								
Graduation	Order No.		Range (range/rev)	Accuracy		Repeatability	Dial reading	Measuring force		
	w/ lug	Flat-back		First 1 Rev / 2.5 Rev / 10 Rev	Retrace					
0.01mm	3052S-11	3052SB-11	30mm (1mm)	±10µm / ±10µm / ±15µm	4µm	±3µm	±0-100	2.5N or less		
0.01mm	3058S-11	3058SB-11	50mm (1mm)	±15µm / ±15µm / ±20µm	5µm	±3µm	±0-100	3.0N or less		

Inch		ANSI/AGD type								
Graduation	Order No.		Range (range/rev)	Accuracy		Repeatability	Dial reading	Measuring force		
	w/ lug	Flat-back		First 1 Rev / 2.5 Rev / 10 Rev	Retrace					
.001"	3414S	3414SB	.5" (.1")	±.001" / ±.001" / ±.001"	.0002"	±.0002"	0-100	1.8N or less		
.001"	3415S	3415SB	.5" (.1")	±.001" / ±.001" / ±.001"	.0002"	±.0002"	0-50-0	1.8N or less		
.001"	3416S	3416SB	1" (.1")	±.001" / ±.001" / ±.002"	.0002"	±.0002"	±0-100	1.8N or less		
.001"	3417S	3417SB	1" (.1")	±.001" / ±.001" / ±.002"	.0002"	±.0002"	0-50-0	1.8N or less		
.001"	3424S-19	3424SB-19	2" (.1")	±.001" / ±.001" / ±.002"	.00033"	±.0002"	±0-100	3.0N or less		
.001"	3426S-19*	3426SB-19*	3" (.1")	±.001" / ±.001" / ±.002"	.00033"	±.0002"	±0-100	3.0N or less		
.001"	3428S-19*	3428SB-19*	4" (.1")	±.001" / ±.001" / ±.002"	.00033"	±.0002"	±0-100	3.2N or less		
.0005"	3570S-10	3570SB-10	.075" (.03")	±.0005" / ±.0005" / —	.00016"	±.0001"	0-30	1.8N or less		
.0005"	3571S-10	3571SB-10	.075" (.03")	±.0005" / ±.0005" / —	.00016"	±.0001"	0-15-0	1.8N or less		
.0001"	3802S-10	3802SB-10	.025" (.01")	±.0001" / ±.0001" / —	.0001"	±.00003"	0-5-0	2.0N or less		
.0001"	3803S-10	3803SB-10	.025" (.01")	±.0001" / ±.0001" / —	.0001"	±.00003"	0-10	2.0N or less		
.001"	4410S	4410SB	.25" (.1")	±.001" / ±.001" / —	.0002"	±.0002"	±0-100	1.8N or less		
.001"	4887S-19*	4887SB-19*	3" (.1")	±.001" / ±.001" / ±.002"	.00033"	±.0002"	±0-100	3.0N or less		
.0005"	4570S-10	4570SB-10	.075" (.03")	±.0005" / ±.0005" / —	.00016"	±.0001"	0-30	1.8N or less		
.0001"	4802S-10	4802SB-10	.025" (.01")	±.0001" / ±.0001" / —	.0001"	±.00003"	0-10	2.0N or less		
.0001"	4803S-10	4803SB-10	.025" (.01")	±.0001" / ±.0001" / —	.0001"	±.00003"	±0-100	2.0N or less		

*Use in a vertical position only.

DIMENSIONS

Order No.	A	B	C	D	E	F	G	H	I
3414S	51.3	73.4	78	17.7	19	12.6	21.8	71	9
3415S	51.3	73.4	78	17.7	19	12.6	21.8	71	9
3416S	52.6	86.1	78	17.7	19	12.6	34.5	71	9
3417S	52.6	86.1	78	17.7	19	12.6	34.5	71	9
3424S-19	84	149.3	78	17.7	19	50.6	59.7	71	9
3426S-19*2	120.9	198.1	78	17.7	19	73.9	85.2	71	9
3428S-19*2	144	244.5	78	17.7	19	94.9	110.6	71	9
3570S-10	61.2	62.1	78	17.7	19	12.6	10.5	71	9
3571S-10	61.2	62.1	78	17.7	19	12.6	10.5	71	9
3803S-10	61.2	59.7	78	17.7	19	12.6	8.1	71	9
3802S-10	61.2	59.7	78	17.7	19	12.6	8.1	71	9
4410S	61.2	74.3	92	21.5	19	12.9	15.4	71	9
4570S-10	61.2	69.4	92	21.5	19	12.9	10.5	71	9
4802S-10	61.2	67	92	21.5	19	12.9	8.1	71	9
4803S-10	61.2	67	92	21.5	19	12.9	8.1	71	9

Unit: mm

*2 Use in a vertical position (contact point downward) for the low measuring force model and the long stroke model.

ANSI/AGD Type Metric Dial Indicator

with 3/8" DIA. Stem and #4-48UNF-Thread Contact Point Compatible Type

SPECIFICATIONS

Metric Series 1 ANSI/AGD type

Graduation	Order No.		Range (range/rev)	Accuracy		Repeat-ability	Dial reading	Measuring force
	w/ lug	Flat-back		First 1 Rev / 2.5 Rev / 10 Rev	Retrace			
0.01mm	1230S-01	1230SB-01	2.5mm (1mm)	±10µm / ±10µm / —	3µm	±2µm	0-100	1.4N or less
0.01mm	1231S-01	1231SB-01	2.5mm (1mm)	±10µm / ±10µm / —	3µm	±2µm	0-50-0	1.4N or less
0.01mm	1044S-01	1044SB-01	5mm (1mm)	±10µm / ±10µm / ±13µm	3µm	±3µm	±0-100	1.4N or less
0.01mm	1045S-01	1045SB-01	5mm (1mm)	±10µm / ±10µm / ±13µm	3µm	±3µm	0-50-0	1.4N or less
0.002mm	1010S-11	1010SB-11	0.5mm (0.2mm)	±2µm / ±2µm / —	2µm	±1µm	0-20	1.5N or less
0.002mm	1011S-11	1011SB-11	0.5mm (0.2mm)	±2µm / ±2µm / —	2µm	±1µm	0-10-0	1.5N or less

Metric Series 2 ANSI/AGD type

Graduation	Order No.		Range (range/rev)	Accuracy		Repeat-ability	Dial reading	Measuring force
	w/ lug	Flat-back		First 1 Rev / 2.5 Rev / 10 Rev	Retrace			
0.01mm	2230S-01	2230SB-01	2.5mm (1mm)	±10µm / ±10µm / —	3µm	±3µm	±0-100	1.4N or less
0.01mm	2231S-01	2231SB-01	2.5mm (1mm)	±10µm / ±10µm / —	3µm	±3µm	0-50-0	1.4N or less
0.01mm	2231S-11	2231SB-11	2.5mm (1mm)	±10µm / ±10µm / —	3µm	±3µm	0-50-0	1.4N or less
0.01mm	2046S-01	2046SB-01	10mm (1mm)	±10µm / ±10µm / ±13µm	3µm	±3µm	±0-100	1.4N or less
0.01mm	2046S-11	2046SB-11	10mm (1mm)	±10µm / ±10µm / ±13µm	3µm	±3µm	±0-100	1.4N or less
0.01mm	2046S-61	2046SB-61	10mm (1mm)	±10µm / ±10µm / ±13µm	3µm	±3µm	±0-100	2.5N or less
0.01mm	2048S-11	2048SB-11	10mm (1mm)	±10µm / ±10µm / ±13µm	3µm	±3µm	±0-100	1.4N or less
0.01mm	2047S-01	2047SB-01	10mm (1mm)	±10µm / ±10µm / ±13µm	3µm	±3µm	0-50-0	1.4N or less
0.01mm	2047S-11	2047SB-11	10mm (1mm)	±10µm / ±10µm / ±13µm	3µm	±3µm	0-50-0	1.4N or less
0.01mm	2902S-01	2902SB-01	10mm (1mm)	±10µm / ±10µm / ±13µm	3µm	±3µm	100-0	1.4N or less
0.01mm	2050S-01	2050SB-01	20mm (1mm)	±10µm / ±10µm / ±15µm	4µm	±3µm	±0-100	2.0N or less
0.01mm	2050S-11	2050SB-11	20mm (1mm)	±10µm / ±10µm / ±15µm	4µm	±3µm	±0-100	2.0N or less
0.01mm	2056S-01	2056SB-01	25mm (1mm)	±10µm / ±10µm / ±15µm	4µm	±3µm	±0-100	2.5N or less
0.002mm	2010S-11	2010SB-11	0.5mm (0.2mm)	±3µm / ±3µm / —	2µm	±0.3µm	0-20	1.5N or less
0.002mm	2010S-71	2010SB-71	0.5mm (0.2mm)	±3µm / ±3µm / —	2µm	±0.3µm	0-20	2.5N or less
0.002mm	2011S-11	2011SB-11	0.5mm (0.2mm)	±3µm / ±3µm / —	2µm	±0.3µm	0-10-0	1.5N or less
0.001mm	2900S-73*	2900SB-73*	0.08mm (0.1mm)	±2µm / — / —	2µm	±0.3µm	0-50-0	2.0N or less
0.001mm	2109S-11	2109SB-11	1mm (0.2mm)	±3µm / ±3µm / ±4µm	2µm	±0.3µm	0-10-0	1.5N or less
0.001mm	2119S-11	2119SB-11	5mm (0.2mm)	±7µm / ±7µm / ±8µm	2µm	±0.3µm	0-10-0	1.5N or less

*One revolution type

Metric Series 3 ANSI/AGD type

Graduation	Order No.		Range (range/rev)	Accuracy		Repeat-ability	Dial reading	Measuring force
	w/ lug	Flat-back		First 1 Rev / 2.5 Rev / 10 Rev	Retrace			
0.01mm	3052S-11	3052SB-11	30mm (1mm)	±10µm / ±10µm / ±15µm	4µm	±3µm	±0-100	2.5N or less
0.01mm	3058S-11	3058SB-11	50mm (1mm)	±15µm / ±15µm / ±20µm	5µm	±3µm	±0-100	3.0N or less

FEATURES

Metric ANSI/AGD type

Order No.								
w/ lug	Flat-back							
1230S-01	1230SB-01	—	—	—	—	—	—	—
1231S-01	1231SB-01	—	—	—	—	—	—	—
1044S-01	1044SB-01	—	—	—	—	—	—	—
1045S-01	1045SB-01	—	—	—	—	—	—	—
1010S-11	1010SB-11	—	✓	—	—	—	—	—
1011S-11	1011SB-11	—	✓	—	—	—	—	—

Metric ANSI/AGD type

Order No.									
w/ lug	Flat-back								
2230S-01	2230SB-01	—	—	—	—	—	—	—	—
2231S-01	2231SB-01	—	—	—	—	—	—	—	—
2231S-11	2231SB-11	—	✓	—	—	—	—	—	—
2046S-01	2046SB-01	—	—	—	—	—	—	—	—
2046S-11	2046SB-11	—	✓	—	—	—	—	—	—
2046S-61	2046SB-61	✓	—	—	—	—	—	—	—
2048S-11	2048SB-11	—	✓	✓	✓	—	—	—	—
2047S-01	2047SB-01	—	—	—	—	—	—	—	—
2047S-11	2047SB-11	—	✓	—	—	—	—	—	—
2902S-01	2902SB-01	—	—	—	—	—	—	—	—
2050S-01	2050SB-01	—	—	—	—	—	—	—	—
2050S-11	2050SB-11	—	✓	—	—	—	—	—	—
2056S-01	2056SB-01	—	—	—	—	—	—	—	—
2010S-11	2010SB-11	—	✓	—	—	✓	—	—	—
2010S-71	2010SB-71	✓	✓	—	—	—	—	—	—
2011S-11	2011SB-11	—	✓	—	—	✓	—	—	—
2900S-73*	2900SB-73*	—	✓	—	—	✓	✓	—	—
2109S-11	2109SB-11	—	✓	—	—	✓	—	—	—
2119S-11	2119SB-11	—	✓	—	—	—	—	—	—

Metric ANSI/AGD type

Order No.								
w/ lug	Flat-back							
3052S-11	3052SB-11	✓	✓	✓	—	—	—	—
3058S-11	3058SB-11	✓	✓	✓	—	—	—	—



(Refer to page IX for details.)

Optional Accessories

- : Backs (See page F-40.)
- : Contact points (See page F-36.)

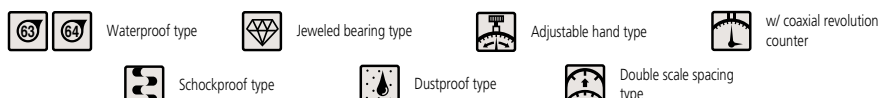

Hicator, Signal Hicator

SERIES 524 — High Accuracy One-Revolution Dial Indicator

FEATURES

The Hicator is Mitutoyo's ultra-sensitive, one-revolution dial indicator. The spindle is made of highly durable stainless steel, and features jeweled bearings for extreme sensitivity as well as a shock-proof and dust-proof structure.

- The maximum, minimum, or runout value can be displayed during measurement.

- The Hicator is capable of comparative measurements to 0.0005mm.
- Connected to an optional Signal Box, the Signal Hicator can output limit signals to perform GO/±NO-GO judgment.
- Splash-proof structure.
- Lug-on-center back is optional.



Optional Accessories

- 524-001: Signal box (100V AC)
- 524-001A: Signal box (120V AC)
- : Backs (See page F-40.)
- : Contact points (See page F-36.)

ABSOLUTE Digimatic Indicator ID-C

SERIES 543 — Signal Output Function Type



FEATURES (See page F-7)

- With the Max/Min Value holding function, the Signal ID-C indicator can output a GO/±NG judgment result against the tolerance values set. Substituting for the traditional mechanical/electrical contact, the judgment is carried out by direct numerical comparison with the peak measurement data obtained. This provides high reliability with no drift of tolerance value setting.

SPECIFICATIONS

Metric		Hicator						ISO/JIS type
Graduation	Order No.*	Range	Dial reading	Spindle travel	Accuracy	Measuring force	Remarks	
0.001mm	524-501	±0.05mm	50-0-50	3mm	±1μm	1.2N or less	w/ spindle lifting cable	
0.0005mm	524-500	±0.03mm	30-0-30	3mm	±0.5μm	1.2N or less	w/ spindle lifting cable	

*Flat back

Metric		Signal Hicator						ISO/JIS type
Graduation	Order No.*	Range	Dial reading	Spindle stroke	Accuracy	Measuring force	Remarks	
0.01mm	524-603	±0.5mm	50-0-50	3mm	±5μm	1.2N or less	w/ 2m signal cable	
0.002mm	524-602	±0.1mm	100-0-100	3mm	±1.5μm	1.2N or less	w/ 2m signal cable	
0.001mm	524-601	±0.05mm	50-0-50	3mm	±1μm	1.2N or less	w/ 2m signal cable	

*Flat back

DIMENSIONS

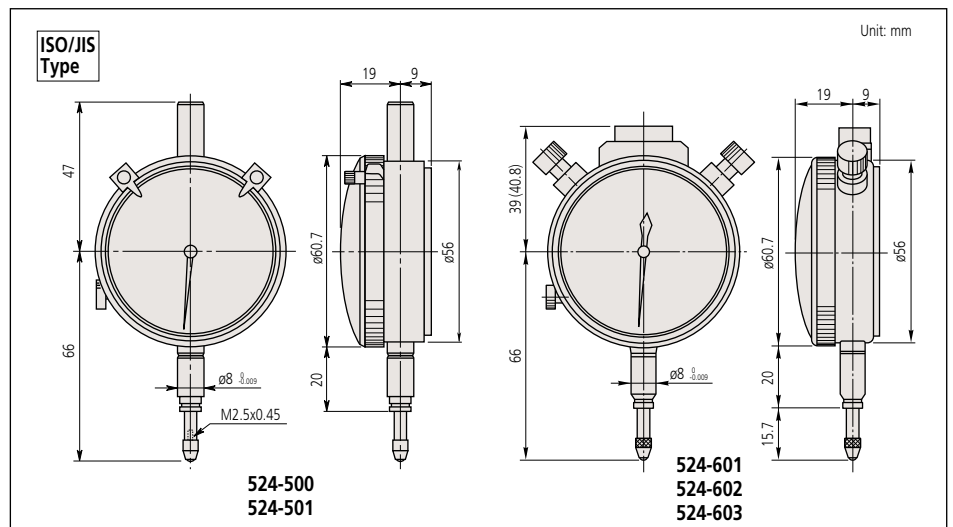

Back Plunger Type Dial Indicator

SERIES 1 and 2

Mitutoyo's back plunger type dial indicators are built with the measuring plunger (or spindle) protruding from the back of the body instead of the side. This type of indicator offers the same precision and durability as all other Mitutoyo dial indicators, and operates very effectively with optional holding bars.

- Back plunger type dial gauges are suitable for mounting onto leveling machine tool tables or inspection jigs, and for use in small spaces where the graduations of standard dial gauges are difficult to see.
- Model No. 1960, which uses Mitutoyo's proprietary shock-proofing mechanism, has excellent durability and shock resistance.
- Model No. 2990 provides 0.001mm resolution.



(Refer to page IX for details.)



1160



1960



1180-6

Holding bar (optional)



2960F



2990

Optional Accessories

- 136567:** Holding bar (ø6mm, L=81mm)
- 21AAA166:** Holding bar (ø6mm, L=42mm)
- 136568:** Holding bar (ø8mm, L=81mm)
- 21AAA168:** Holding bar (ø8mm, L=42mm)
- 124625:** Holding bar (.25" DIA, L=3.19")
- 21AAA167:** Holding bar (.25" DIA, L=1.65")
- : Backs (See page F-40.)
- : Contact points (See page F-36.)

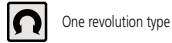

One revolution type



Shockproof type



Jeweled bearing type

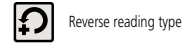

Reverse reading type

FEATURES

Order No.						
1960	✓	✓	—	—	—	—
1160	—	—	—	—	—	—
1162	—	—	✓	—	—	—
1180-6	—	—	—	—	—	—
1180-7	—	—	—	—	—	—
1180-8	—	—	—	—	—	—

Order No.						
1961	✓	✓	—	—	—	—
1156	—	—	—	—	—	—
1157	—	—	—	—	—	—
1166	—	—	—	—	—	—
1167	—	—	—	—	—	—
1168	—	—	✓	—	—	—

Order No.						
2960F	✓	✓	—	—	—	—
2990	✓	✓	✓	—	—	—

Order No.						
2961	✓	✓	—	—	—	—
2991	✓	✓	✓	—	—	—

SPECIFICATIONS

Metric		Series 1						ISO/JIS type
Graduation	Order No.	Range (range/rev)	Accuracy				Dial reading	Measuring force
			Overall	Retrace	1/10 Rev	1 Rev		
0.01mm	1960	1mm / 1.27mm*	±14µm	7µm	10µm	—	50-0-50	1.4N or less
0.01mm	1160	5mm (1mm)	±16µm	7µm	10µm	±14µm	0-100	1.4N or less
0.01mm	1162	5mm (1mm)	±16µm	7µm	10µm	±14µm	100-0	1.4N or less
0.01mm	1180-6	5mm (1mm)	±16µm	7µm	10µm	±14µm	0-100	1.5N or less
0.01mm	1180-7	5mm (1mm)	±16µm	7µm	10µm	±14µm	0-100	1.5N or less
0.01mm	1180-8	5mm (1mm)	±16µm	7µm	10µm	±14µm	0-100	1.5N or less

Inch		Series 1						ANSI/AGD type
Graduation	Order No.	Range (range/rev)	Accuracy				Dial reading	Measuring force
			First 1 Rev / 2.5 Rev / 10 Rev	Retrace				
.001"	1961	.04" / .05"*	±.001" / — / —	.0002"			20-0-20	1.4N or less
.001"	1156	.1" (.1")	±.001" / — / —	.00033"			0-100	2.1N or less
.001"	1157	.1" (.1")	±.001" / — / —	.00033"			0-50-0	2.1N or less
.001"	1166	.2" (.05")	±.001" / ±.001" / ±.001"	.00033"			0-50	1.4N or less
.001"	1167	.2" (.05")	±.001" / ±.001" / ±.001"	.00033"			0-25-0	1.4N or less
.001"	1168	.2" (.05")	±.001" / ±.001" / ±.001"	.00033"			50-0	1.4N or less

*Full stroke

Metric		Series 2						ISO/JIS type
Graduation	Order No.	Range (range/full stroke)	Accuracy				Dial reading	Measuring force
			Overall	Retrace	1/10 Rev	1 Rev		
0.01mm	2960F	1mm / 1.27"	±14µm	7µm	10µm	—	50-0-50	1.4N or less
0.001mm	2990	0.1mm / 0.14"	±6.5µm	4µm	4µm	—	50-0-50	1.5N or less

Inch		Series 2						ANSI/AGD type
Graduation	Order No.	Range (range/full stroke)	Accuracy				Dial reading	Measuring force
			First 1 Rev / 2.5 Rev / 10 Rev	Retrace				
.0005"	2961F	.04" / .05"	±.001" / — / —	.0002"			20-0-20	1.4N or less
.0001"	2991	.008" / .01"	±.0002" / — / —	.0001"			4-0-4	1.5N or less

DIMENSIONS

ANSI/AGD Type

Order No.	A	B	C	D	E	F	G	H	I
1156	41	22	35	6.35	22	15.5	8.5	30.7	81
1157	41	22	35	6.35	22	15.5	8.5	30.7	81
1166	39.6	22	35	—	22	25	13	42	—
1167	39.6	22	35	—	22	25	13	42	—
1168	39.6	22	35	—	22	25	13	42	—
1961	39.6	22	35	—	22	25	10.9	40	—
2961F	55.6	23	35	—	22	25	10.9	40	—
2991	58	40	51	—	25.5	26.5	13.5	55.5	—

ISO/JIS Type

Order No.	A	B	C	E	F	G	H
1160	39	21.5	35	22	25	13.8	43.3
1162	39	21.5	35	22	25	13.8	43.3
1180-6	39	21.5	35	22	9.5	13.8	27.8
1180-8	39	21.5	35	22	9.5	13.8	27.8
1960	39	21.5	35	22	28.7	12.8	46

Unit: mm

Note 1: Dimensions of the inch (ANSI/AGD Type) dial indicator partly differ from those of the metric (ISO/JIS Type) indicator.
 Note 2: Inch (ANSI/AGD Type) dial indicator is provided with a stem of 3/8" dia. and #4-48UNF thread mount for the contact point.

Contact Points

Optional Accessory for Digimatic and Dial Indicators and Linear Gages

SPECIFICATIONS

Ball Point

Standard contact point.

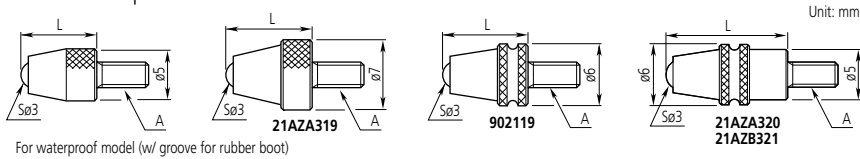

For waterproof model (w/ groove for rubber boot)

A: M2.5x0.45

L	Material		Ruby	Plastic
	Without groove	With groove (waterproof type)		
7.3	901312	—	120047	901994
8.3	21AZA319	21AZA319	—	—
12.1	—	21AZA320	—	—
14	21JAA225	—	—	—
15	120049	—	120051	—
17	21JAA224	—	—	—
19.3	—	21AAA321	—	—
20	137391	—	137392	—
22	21JAA226	—	—	—
25	120053	—	120055	—
30	21AAA252	—	21AAA253	—

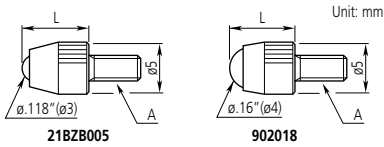

A: 4-48UNF

L	Material	
	Carbide	Plastic
1/4"	21BZB005	902018

Ball Point

Optimal for workpieces with deep indentations.

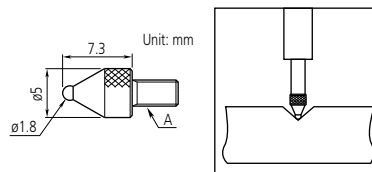

A: M2.5x0.45

SøD	ød	Order No.
1mm, carbide	5mm	21AAA349
1.5mm, carbide	5mm	21AAA350
1.8mm, steel	5mm	101122
2.5mm, carbide	5mm	21AAA351
4mm, carbide	5mm	21AAA352

Shell Type Point

Contact point with a large radius.
Optimal for use on flat surfaces.

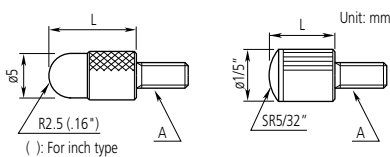

A: M2.5x0.45

L	Order No.
5	101386
10	101118
15	137393
20	101387
25	101388
30	21AAA254

A: 4-48UNF

L	Order No.
3/32"	193697
5/32"	101184
1/4"	21AAA031
3/8"	21AAA032
1/2"	101185
5/8"	21AAA033
3/4"	101186
7/8"	21AAA034
1"	101187
1 1/4"	21AAA035
1 1/2"	21AAA036
1 3/4"	21AAA037
2"	21AAA038
2 1/4"	21AAA039
2 1/2"	21AAA040
2 3/4"	21AAA041
3"	21AAA042

Spherical Point

A large radius makes this contact point optimal for use where the workpiece needs to slide from the side.

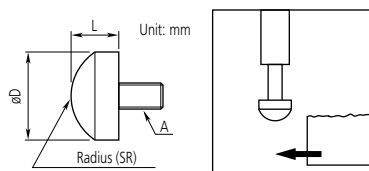

A: M2.5x0.45

D	L	SR	Order No.
5.5	3	5	111460
7.9	5	5	125258
10	5	7	101119

A: 4-48UNF

D	L	SR	Order No.
1/2"	1/8"	.28"	101205
3/8"	3/32"	.35"	101204

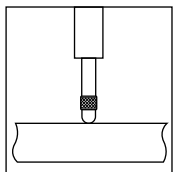

Spherical Point (Carbide)

A large radius makes this contact point optimal for use where the workpiece needs to slide from the side.

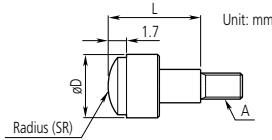

A: M2.5x0.45

D	L	SR	Order No.
5.2	5	5	120058
7.5	10	7	120059
10.5	10	10	120060

Conical Point

Used for positioning the measurement point. Since it can damage a workpiece easily, it is not suitable for use on soft materials.

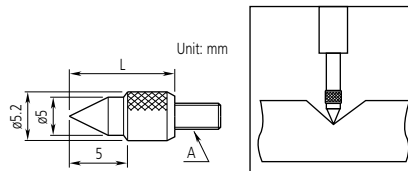

A: M2.5x0.45

Tip angle	L	Order No.
60°	10	101120

A: 4-48UNF

L	A	Order No.
1/2"	.2"	101190

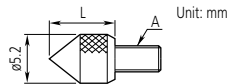

A: M2.5x0.45

Tip angle	L	Order No.
90°	5	101385

A: 4-48UNF

D	L	Order No.
.2"	1/4"	101191

Knife Edge Point (Carbide)

Suitable for measuring narrow groove diameter, etc.

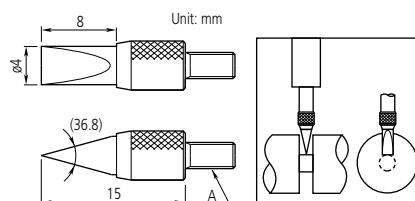

A: M2.5x0.45

Order No.
120067

Conical Point (Carbide)

Used for positioning the measurement point. Since it can damage a workpiece easily, it is not suitable for use on soft materials.

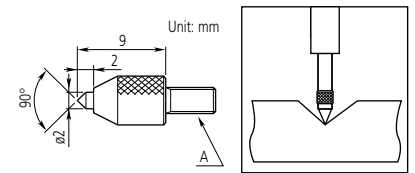

A: M2.5x0.45

Order No.
120057

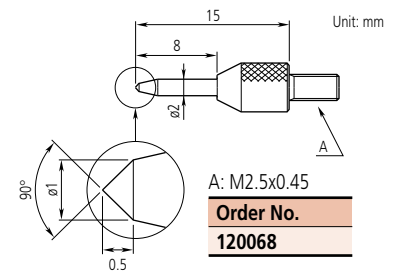

A: M2.5x0.45

Order No.
120068

Flat Point

Optimal for use on convex surfaces.

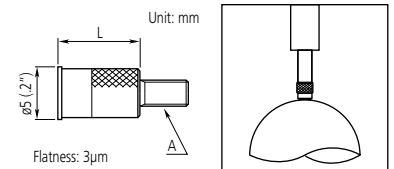

A: M2.5x0.45

L	Order No.
8	131365
10	21AAA340

A: 4-48UNF

L	Order No.
5/16"	133017
1/2"	21AAA043
3/4"	21AAA044
1"	21AAA045

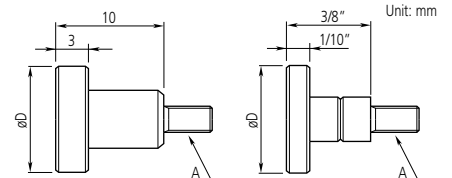

A: M2.5x0.45

D	Order No.
10	10117
15	21AAA341
20	21AAA342
25	21AAA343
30	21AAA344

A: 4-48UNF

D	Order No.
1/2"	101188
3/8"	101189

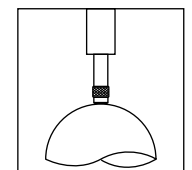

Flat Point (Carbide)

Optimal for use on convex surfaces.

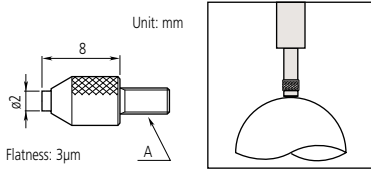

A: M2.5x0.45

Order No.
120056

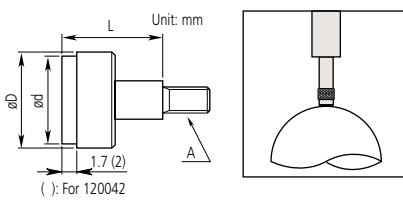

A: M2.5x0.45

D	d	L	Order No.
5.2	4.3*	5	120041
7	6.5*	10	120042
10.5	9.5*	10	120043
17	15**	10	21AAA345
22	20**	10	21AAA346
27	25**	10	21AAA347
32	30**	10	21AAA348

Flatness: *3µm, **5µm

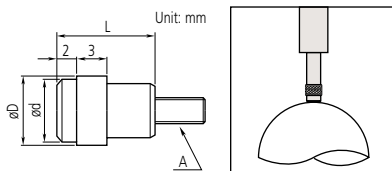

A: M2.5x0.45

D	d	L	Order No.
7	6.4	10	137255
9	8	10	137399

Lever Point

Suitable for use on perpendicular faces, such as those within mold cavities. Lever can be adjusted to the required angle.

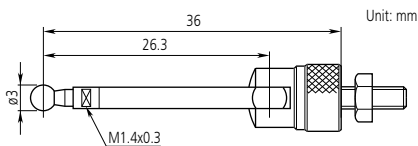

A: M2.5x0.45

Order No.
900391

A: 4-48UNF

Order No.
900393

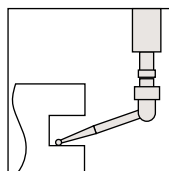

Needle Point

Suitable for probing the bottom of a groove or hole.

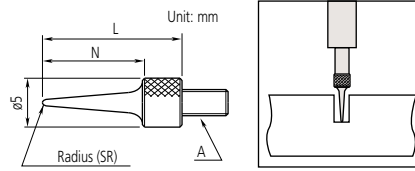

A: M2.5x0.45

N	L	SR	Order No.
11	15	0.4	101121
13	17	0.2	137413
21	25	0.4	21AAA255
31	35	0.4	21AAA256

A: 4-48UNF

L	SR	Order No.
.6"	.016"	21AAA030
1"	.016"	21AAA046
1 1/2"	.016"	21AAA047
2"	.016"	21AAA048

Needle Point (Carbide)

Suitable for probing the bottom of a groove or hole.

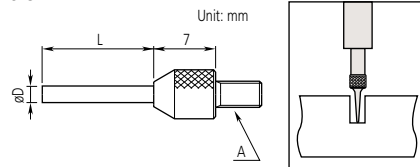

A: M2.5x0.45

D	L	Order No.
0.45	3	120066
0.45	5	21AAA329
1	3	120065
1	5	21AAA330
1	8	21AAA331
1	10	21AAA332
1.5	5	21AAA335
1.5	10	21AAA336
1.5	13	120064
1.5	20	21AAA337
1.5	40	21AAA338
2	8	137257
2	18	21AAA257
2	28	21AAA258
2	40	21AAA339

Blade Point (Carbide)

Suitable for use on convex surfaces, especially those with shallow grooves.

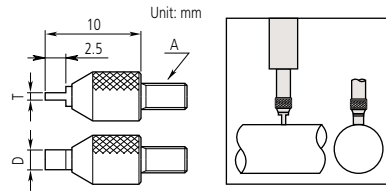

A: M2.5x0.45

T	W	Order No.
0.4	2	120061
0.6	2	120062
1	4	120063

Roller Point

Suitable for use on a moving workpiece surface, or where the workpiece needs to slide from the side.

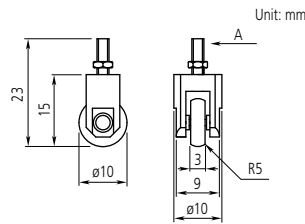

A: M2.5x0.45

Order No.
901954

A: 4-48UNF

Order No.
901991

Extension Rod

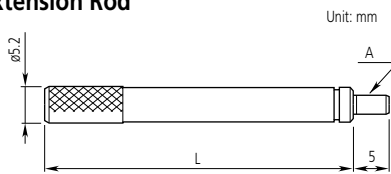

A: M2.5x0.45

L	Order No.
10	303611
15	21AAA259A
20	303612
25	21AAA259B
30	303613
35	21AAA259C
40	21AAA259D
45	21AAA259E
50	21AAA259F
55	21AAA259G
60	304146
65	21AAA259H
70	21AAA259J
75	21AAA259L
80	21AAA259M
90	304147
100	303614

A: 4-48UNF

L	Order No.
1/2"	139167
1"	301655
2"	301657
4"	301659

Interchangeable Contact Point Set

This set consists of six types of popular contact point for extending the use of an indicator to many applications.



A: M2.5x0.45

Order No.	Contact points included
7822	Flat Point (131365, ø5mm)
	Flat Point (101117, ø10mm)
	Needle Point (101121)
	Spherical Point (101119)
	Shell Type Point (101118)
	Shell Type Point (101387)

A: 4-48UNF

Order No.	Contact points included
21AZA034	Shell Type Point (101184, 5/32")
	Shell Type Point (101185, 1/2")
	Shell Type Point (101186, 3/4")
	Shell Type Point (101187, 1")
	Flat Point (101188, ø1/2")
	Flat Point (101189, ø3/8")
	Conical Point (101190, 60°)
	Conical Point (101191, 90°)
	Spherical Point (1011204, ø3/8")
	Lever Point (21AAA030, .6")

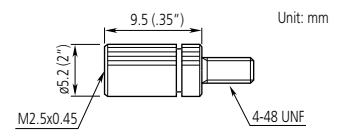

Order No.
21AAA011

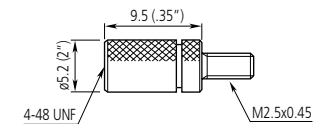











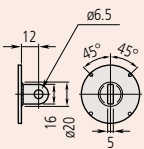

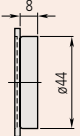

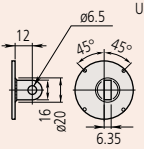

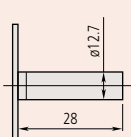
Order No.
21AAA012

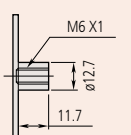
Interchangeable Backs

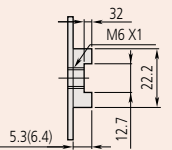
Optional Accessory for Digimatic and Dial Indicators

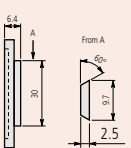
SPECIFICATIONS

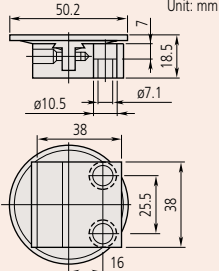
Description		Order No.		
		Series 1 ($\phi 41$ mm)	Series 2 ($\phi 57$ mm)	Series 3, 4 ($\phi 77, 91$ mm)
Flat Back 	 Unit: mm	101211: a=2.2 136872: for water-proof type 191559: for 1911, 1913-10, 1921, 1923, 1925-10, 1927-10 137906: for 1003	101039: a=2.5 21AZB231: for water-proof of S type 192910: (F type waterproof model)	100836: a=3.0
Lug-on-Center Back 	 Unit: mm	101210: metric type 101307: inch type 190561: for 1911, 1913-10, 1921, 1923, 1925-10, 1927-10 192910: 137905: for 1003	101040: metric type 101306: inch type 21AZB230: for water-proof of S type	100691: metric type 100797: inch type
Magnetic Back 	 Unit: mm	Special order	900928	900929
Back with Offset Lug 	 Unit: mm	Special order	101167	100837
Back with Post 	 Unit: mm	193172 Custom made	101169	100839
Back with Screw Mount 	 Unit: mm	193173: M6x1, Custom made 193174: #1/4-28UNF, Custom made	136023: M6x1 101170: #1/4-28UNF	136024: M6x1 100840: #1/4-28UNF
Adjustable Back 	 Unit: mm	136025: M6x1 129721: #1/4-20UNF	136026: M6x1 101168: #1/4-20UNF)	136027: M6x1 100838: #1/4-20UNF
Back with Dovetail 	 Unit: mm	—	900008	Special order
Back with Adjustable Bracket 	 Unit: mm	—	901963	—

A dial or Digimatic indicator may be held in position by clamping on either the stem or the lug on the back of the indicator. The back of the indicator may need to be interchanged with another type for special applications. A wide variety of backs are available for Mitutoyo Digimatic and dial indicators.

Application

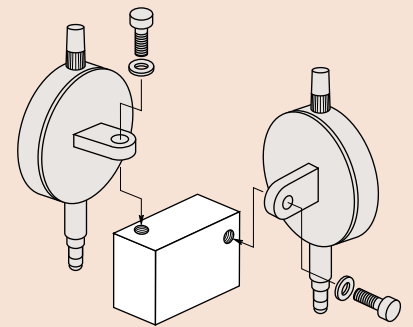

Spindle Lifting Lever and Cable

Optional Accessories for Digimatic and Dial Indicators

Spindle Lifting Lever

- The Spindle Lifting Lever is attached to the top end of the spindle for improved inspection efficiency when using a dial indicator mounted on a stand.

902100

Use for S type Series 1 and F type Series 2 (up to 10mm/.4" range) dial indicators.



21AZB149

Use for S type Series 2, 3, and 4 dial indicators (up to 10mm/.4").



21AZB150

Use for S type Series 2 and 3 dial indicators (from 10mm/.4" up to 20mm/.8").



Spindle Lifting Cable

901975: with auto-stop function



Spindle Lifting Knob

137693

Suitable for 4.8mm spindle diameter.



Application

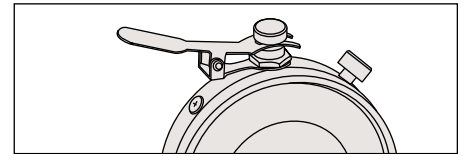
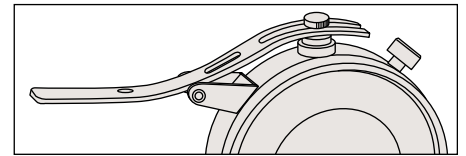

21BZA205

Use for F type Series 1 dial indicators.



900527: Lever
101171: Screw

902011

Use for F type Series 2 dial indicators (up to 10mm/.4" range).



903424

Use for F type Series 2 dial indicators (up to 20mm/.8" range) and Series 3 and 4 dial indicators (up to 10mm/.4" range).



903307: Lever
192686: Screw

Application

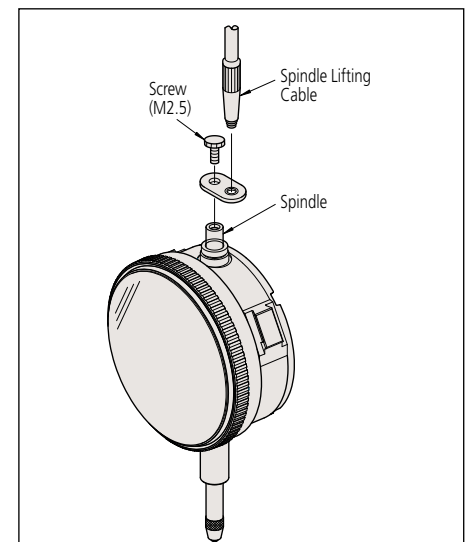

Color-coded Spindle Caps

Optional Accessory for Digimatic and Dial Indicators

8 color-coded spindle caps are available for dial indicators with a range of 10mm or less.

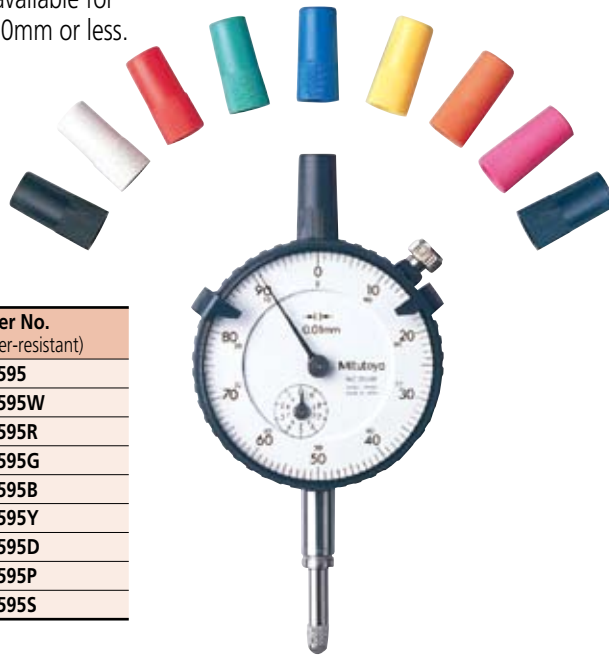

SPECIFICATIONS

Color	Order No. (normal)	Order No. (water-resistant)
Black	193051	193595
White	193051W	193595W
Red	193051R	193595R
Green	193051G	193595G
Blue	193051B	193595B
Yellow	193051Y	193595Y
Orange	193051D	193595D
Pink	193051P	193595P
Dark blue	193051S	193595S

Limit Stickers

Optional Accessory for Digimatic and Dial Indicators

FEATURES

- Stuck on the dial face or crystal of a Series 2 dial indicator (55.6mm or 57mm bezel dia.) to indicate tolerance limits.



136420: Red (10-sheet/set)



136421: Green (10-sheet/set)



136422: Yellow (10-sheet/set)

Dial Indicator Repair Tool Kit

Optional Accessory for Digimatic and Dial Indicators

Set Configuration

- 901171: Grease
- 21JAA273: Reamer for pointer (ø0.5:1/20 taper)
- 21JAA313: Lubricating oil
- 21JAA314: Stick
- 901173: Screwdriver (Phillips)
- 901174: Screwdriver (Phillips/flat blade)
- 126628: Pointer removing
- 126630: Pointer removing (ø0.8)
- 126630B: Pointer removing (ø0.5)
- 126630C: Pointer removing (ø1.6)
- 129729: Tweezers
- 901175: Pin-vise
- 901176: Brush
- 901177: Brush
- 901178: Hammer
- 129730: Spindle rest
- 129731: Pin rest
- 901179: Nippers
- 901180: Pliers
- 901181: Hand remover
- 129732: Pin remover
- 129733: Punch
- 129734: Bearing adjuster
- 129735: Pinion rest
- 129736: Reamer ø1
- 193702: Reamer ø0.6
- 901182: Case
- 100699: Adjustable nut

Mitutoyo offers a tool set designed to let you perform simple repairs to your Mitutoyo dial indicator, and a device that lets you replace indicator crystals.



7823

Dial Indicator Crystal Setter

Optional Accessory for Digimatic and Dial Indicators

FEATURES

- Used for fitting a crystal on dial indicators, dial test indicators, and dial calipers.



7000

With 8 sizes of crystal setting pad

Dial Test Indicators

SERIES 513

FEATURES

- Designed to probe surfaces that cannot be reached with a normal dial gauge. Useful both for alignment and for measurement purposes.
- Mitutoyo's proprietary new design permits smooth pointer operation.
- Use of a hard frame provides excellent rigidity and durability.
- Non-magnetic pointer and contact point permit secure operation even in magnetic environments.
- Use of a clear and concise wide dial face allows excellent visibility.
- The surface of the crystal is hard-coated, to make it scratch-resistant.
- Flat crystal makes graduations easy to read. Moreover, the O-ring sealing method used for the bezel prevents oil and water from permeating via the front face.
- Six types are available: horizontal, horizontal (20° tilted face) vertical, parallel, universal, and pocket, allowing users to select the model most suited to their needs.
- Horizontal: Standard
- Horizontal (20° Tilted Face): Dial face inclined 20°, compared with the vertical type, allows easy reading.
- Vertical: Best suited for centering holes.
- Parallel: The graduations can be read from the front, with the probe on the tip of the horizontal conical rod abutting the workpiece.
- Universal: The direction of the probe movement can be freely changed.
- Pocket: Compact type

Feature icons

Icon	Feature description
	With revolution counter type
	Long stylus type
	Jeweled bearing type
	Double scale spacing type, easy-on-the-eyes
	Compact type
	Dustproof type
	Anti-magnetic type

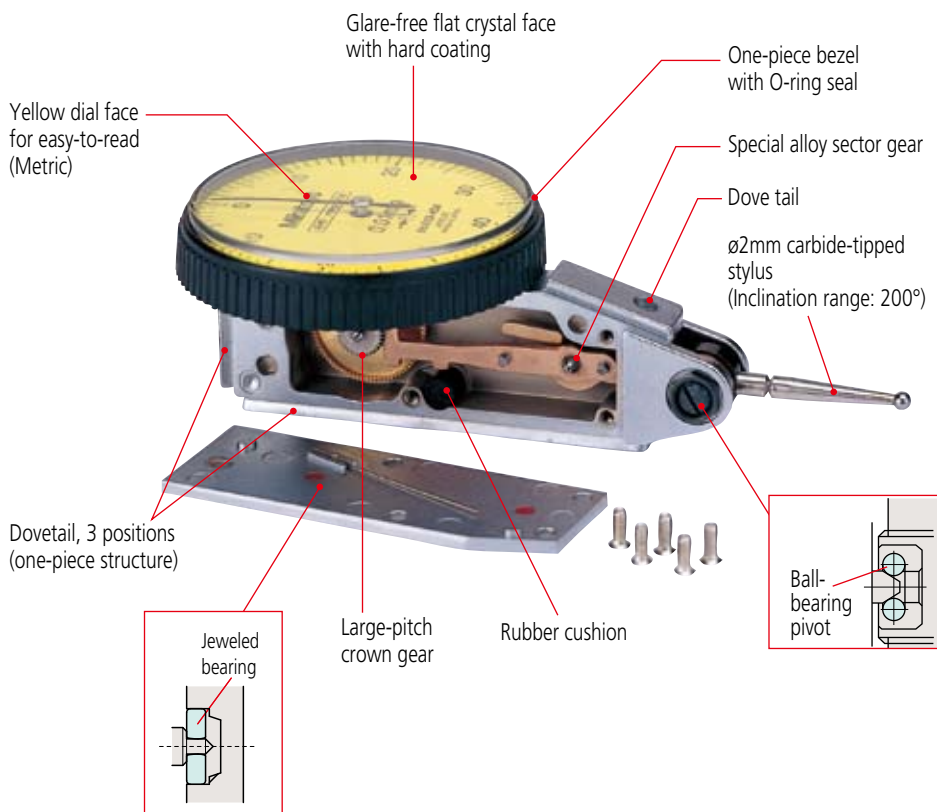

Dial Test Indicator

SERIES 513 — Horizontal Type

FEATURES

- Provides easy access to shrouded surfaces that cannot be reached with conventional dial indicators.
- No-clutch structure for automatic reversal of measuring direction.
- Resistant to water and dust thanks to the one-piece bezel and O-ring seal for the crystal.
- The glare-free flat crystal face has a scratch-resistant coating.
- High-sensitivity and quick-response due to low-friction jeweled bearings.

DIMENSIONS

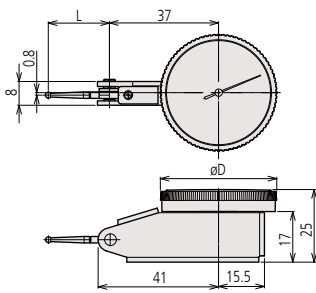

Order No.	L	D
513-424E/513-478E	22.3	Ø40
513-404E/513-474E	20.9	Ø40
513-415E/513-477E	44.5	Ø40
513-426E	22.3	Ø40
513-405E/513-475E	14.7	Ø40
513-425E	14.7	Ø40
513-401E/513-471E	12.8	Ø40
513-466E	22.3	Ø28
513-464E	20.9	Ø28
513-465E	14.7	Ø28
513-414E	36.8	Ø40
513-409	14.7	Ø40

Special Set: No. 513-908 (mm)

513-404E: Dial test indicator
7014: Mini magnetic stand

No. 513-907 (inch)

513-402: Dial test indicator
7014E: Mini magnetic stand

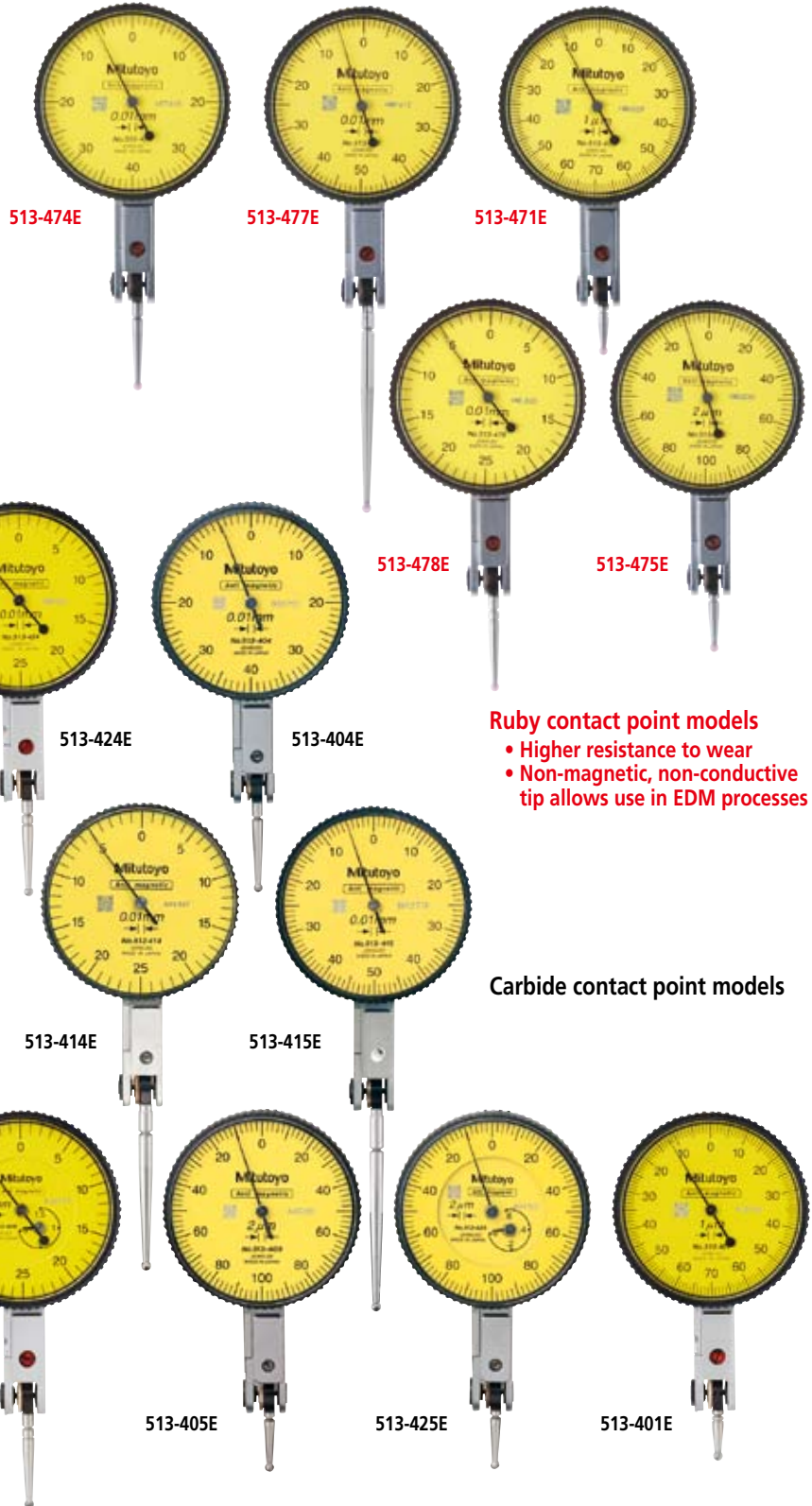

Ruby contact point models

- Higher resistance to wear
- Non-magnetic, non-conductive tip allows use in EDM processes

Carbide contact point models



Anti-magnet type



Double scale spacing type



Long stylus type



Jeweled bearing type



Compact type



With revolution counter type



513-466E



513-464E



513-465E

SPECIFICATIONS

Metric

Graduation	Order No.			Range	Accuracy	Dial reading	Measuring force							
	Basic set	Plus set	Full set											
0.01mm	513-424E	513-424A	513-424T	0.5mm	5µm	0-25-0	0.3N or less	✓	✓	—	✓	—	—	—
0.01mm	513-478E	—	—	0.5mm	5µm	0-25-0	0.3N or less	✓	✓	—	✓	—	—	—
0.01mm	513-414E	513-414A	513-414T	0.5mm	10µm	0-25-0	0.2N or less	✓	✓	✓	✓	—	—	—
0.01mm	513-466E	—	—	0.5mm	5µm	0-25-0	0.3N or less	✓	✓	—	✓	✓	—	—
0.01mm	513-404E	513-404A	513-404T	0.8mm	8µm	0-40-0	0.3N or less	✓	—	—	✓	—	—	—
0.01mm	513-474E	—	—	0.8mm	8µm	0-40-0	0.3N or less	✓	—	—	✓	—	—	—
0.01mm	513-464E	—	—	0.8mm	8µm	0-40-0	0.3N or less	✓	—	—	✓	✓	—	—
0.01mm	513-415E	513-415A	513-415T	1mm	10µm	0-50-0	0.2N or less	✓	—	✓	✓	—	—	—
0.01mm	513-477E	—	—	1mm	10µm	0-50-0	0.2N or less	✓	—	✓	✓	—	—	—
0.01mm	513-426E	513-426A	—	1.5mm	8µm	0-25-0	0.4N or less	✓	✓	—	✓	—	—	✓
0.002mm	513-405E	513-405A	513-405T	0.2mm	3µm	0-100-0	0.3N or less	✓	—	—	✓	—	—	—
0.002mm	513-475E	—	—	0.2mm	3µm	0-100-0	0.3N or less	✓	—	—	✓	—	—	—
0.002mm	513-465E	—	—	0.2mm	3µm	0-100-0	0.3N or less	✓	—	—	✓	✓	—	—
0.002mm	513-425E	513-425A	—	0.6mm	6µm	0-100-0	0.4N or less	✓	—	—	✓	—	—	✓
0.001mm	513-401E	—	—	0.14mm	3µm	0-70-0	0.3N or less	✓	—	—	✓	—	—	—
0.001mm	513-471E	—	—	0.14mm	3µm	0-70-0	0.3N or less	✓	—	—	✓	—	—	—

Provided with a ø2mm ruby contact point as a substitute for ø2mm carbide contact point.

Inch

Graduation	Order No.			Range	Accuracy	Dial reading	Measuring force							
	Basic set	Plus set	Full set											
.0005"	513-402	—	513-402T	.03"	±.0005"	0-15-0	0.3N or less	✓	—	✓	—	—	—	—
.0005"	513-472	—	—	.03"	±.0005"	0-15-0	0.3N or less	✓	—	✓	—	—	—	—
.0005"	513-412	—	513-412T	.03"	±.0005"	0-15-0	0.2N or less	✓	✓	✓	—	—	—	—
.0005"	513-479	—	—	.03"	±.0005"	0-15-0	0.2N or less	✓	✓	✓	—	—	—	—
.0005"	513-462	—	—	.03"	±.0005"	0-15-0	0.3N or less	✓	—	✓	✓	—	—	—
.0001"	513-403	—	513-403T	.008"	±.0001"	0-4-0	0.3N or less	✓	—	✓	—	—	—	—
.0001"	513-473	—	—	.008"	±.0001"	0-4-0	0.3N or less	✓	—	✓	—	—	—	—
.0001"	513-463	—	—	.008"	±.0001"	0-4-0	0.3N or less	✓	—	✓	✓	—	—	—

Provided with a ø2mm ruby contact point as a substitute for ø.079" carbide contact point.

Metric/inch

Graduation	Order No.			Range	Accuracy	Dial reading	Measuring force							
	Basic set	Plus set	Full set											
0.002mm, .0001"	513-409	—	513-409T	0.2mm, .0075"	3µm	0-10-0, 0-3.8-0	0.3N or less	✓	✓	—	—	—	—	—

Inch/Metric

Graduation	Order No.			Range	Accuracy	Dial reading	Measuring force							
	Basic set	Plus set	Full set											
.0005", 0.01mm	513-406	—	513-406T	.03", 0.7mm	±.0005"	0-15-0, 0-35-0	0.3N or less	✓	✓	—	—	—	—	—

Set Configuration: Metric and Metric/Inch

Full set

Swivel clamp (900321, for ø4mm, ø8mm, dovetail)

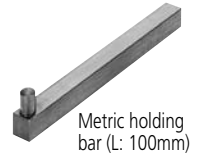

Plus set

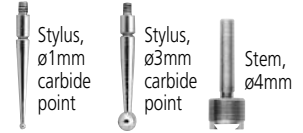

Basic set

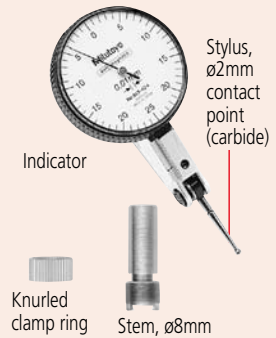

Set Configuration: Inch and Inch/Metric

Full set



Swivel clamp (900322, for .157" DIA., 3/8" DIA., dovetail)

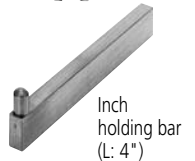

Basic set

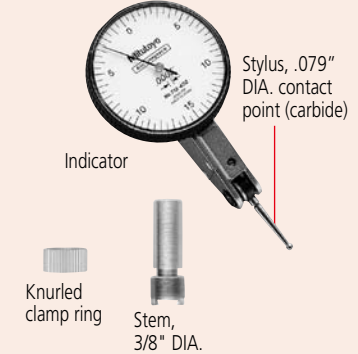

Dial Test Indicator

SERIES 513 — Horizontal (20° Tilted Face), Vertical, and Parallel Types



(Refer to page IX for details.)

FEATURES

- Specially designed for easy viewing of dial.

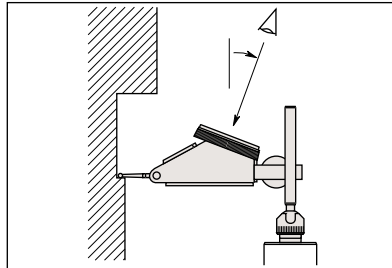

- The dial face obliquely faces upward, allowing users to read the graduations from the user's side. It is convenient when measuring on the side of a large workpiece and the workbench is high.

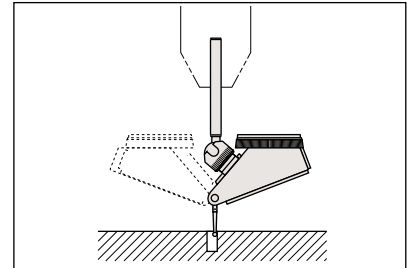

- Using the universal holder allows easy hole centering. The dial face always faces upward when the indicator is rotated, which makes reading easy.



513-444E



513-445E



513-454E
513-284GE



513-455E



513-454E



513-455E



513-444E



513-445E



513-284GE



513-452

Optional Accessories

- : Swivel clamps (See page F-52.)
- : Holding bars (See page F-52.)
- : Stems (See page F-52.)
- : Styli (See page F-52.)



Anti-magnet type

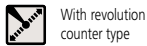

With revolution counter type



Jeweled bearing type

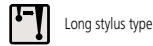

Long stylus type

SPECIFICATIONS

Metric Horizontal (20° tilted face) type

Graduation	Order No.			Range	Accuracy	Dial reading	Measuring force				—	—	—
	Basic set	Plus set	Full set										
0.01mm	513-444E	513-444A	513-444T	1.6mm	10µm	0-40-0	0.3N or less	✓	✓	✓	—	—	—
0.002mm	513-445E	513-445A	513-445T	0.4mm	5µm	0-100-0	0.3N or less	✓	✓	✓	—	—	—

Inch Horizontal (20° tilted face) type

Graduation	Order No.			Range	Accuracy	Dial reading	Measuring force					Remarks
	Basic set	Plus set	Full set									
.0005"	513-442	—	513-442T	.06"	±.0005"	0-15-0	0.3N or less	✓	✓	✓	—	—
.0005"	513-442-01	—	513-442T-01	.06"	±.0005"	0-15-0	0.3N or less	✓	✓	✓	—	Blue dial
.0005"	513-442-06	—	513-442T-06	.06"	±.0005"	0-15-0	0.3N or less	✓	✓	✓	—	Black dial
.0005"	513-446	—	513-446T	.06"	±.0005"	0-15-0	0.2N or less	✓	✓	✓	✓	—
.0005"	513-446-06	—	513-446T-06	.06"	±.0005"	0-15-0	0.2N or less	✓	✓	✓	✓	Black dial
.0001"	513-443	—	513-443T	.016"	±.0002"	0-4-0	0.3N or less	✓	✓	✓	—	—
.0001"	513-443-06	—	513-443T-06	.016"	±.0002"	0-4-0	0.3N or less	✓	✓	✓	—	Black dial

Metric Vertical type

Graduation	Order No.			Range	Accuracy	Dial reading	Measuring force			—	—	—
	Basic set	Plus set	Full set									
0.01mm	513-454E	513-454A	513-454T	0.8mm	8µm	0-40-0	0.3N or less	✓	✓	—	—	—
0.002mm	513-455E	513-455A	513-455T	0.2mm	3µm	0-100-0	0.3N or less	✓	✓	—	—	—

Inch Vertical type

Graduation	Order No.			Range	Accuracy	Dial reading	Measuring force			—	—	—
	Basic set	Plus set	Full set									
.0005"	513-452	—	513-452T	.03"	±.0005"	0-15-0	0.3N or less	✓	✓	—	—	—
.0001"	513-453	—	513-453T	.008"	±.0001"	0-4-0	0.3N or less	✓	✓	—	—	—

Metric Parallel type

Graduation	Order No.			Range	Accuracy	Dial reading	Measuring force		—	—	—	—
	Basic set	Plus set	Full set									
0.01mm	513-284GE	513-284GA	513-284GT	0.8mm	8µm	0-40-0	0.3N or less	✓	—	—	—	—

Inch Parallel type

Graduation	Order No.			Range	Accuracy	Dial reading	Measuring force		—	—	—	—
	Basic set	Plus set	Full set									
.0005"	513-282G	—	513-282GT	.03"	±.0005"	0-15-0	0.3N or less	✓	—	—	—	—

DIMENSIONS

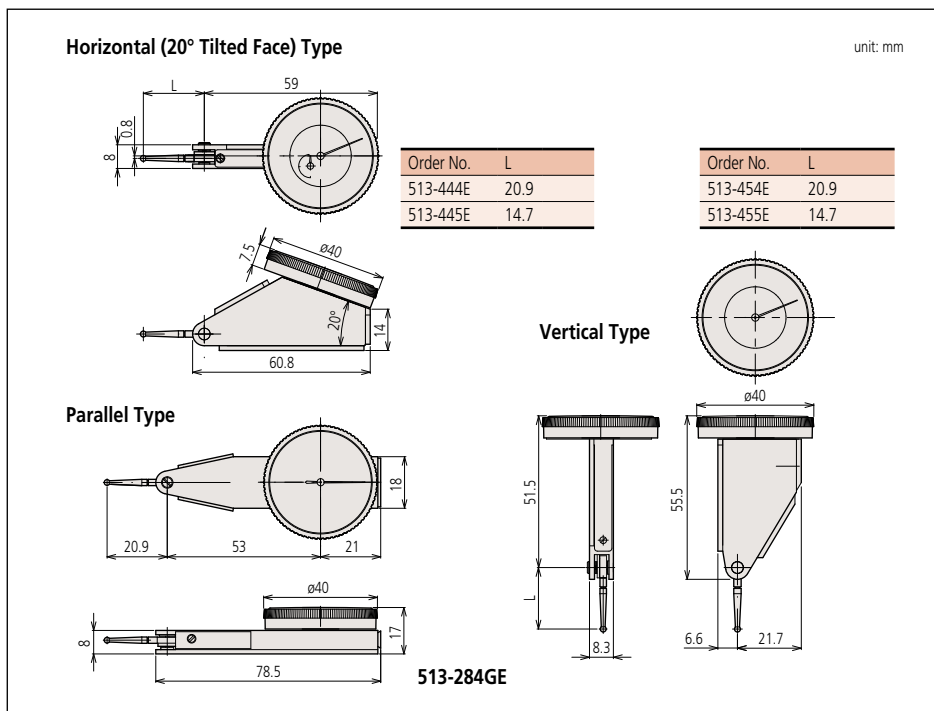

Set Configuration: Metric

Full set

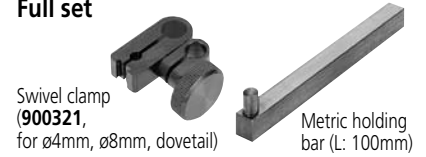

Plus set

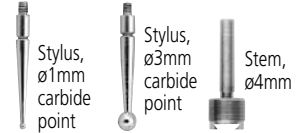

Basic set

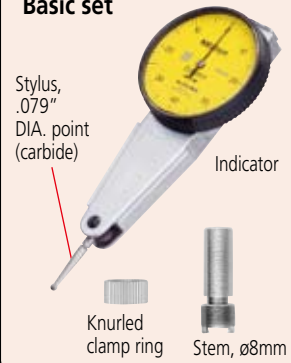

Set Configuration: Inch

Full set



Basic set

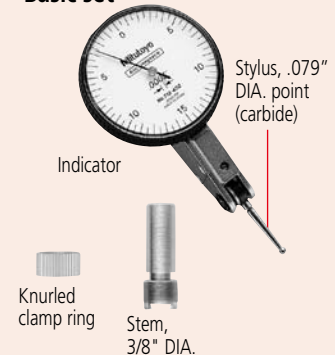

Dial Test Indicator

SERIES 513 — Universal Type

Set Configuration: Metric

Full set

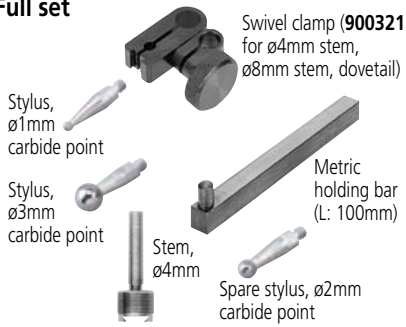

Basic set

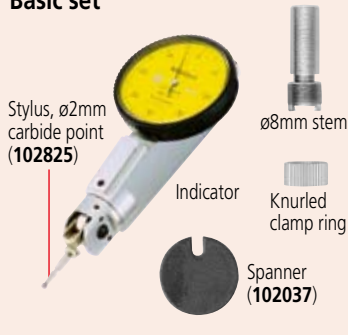

Set Configuration: Inch

Full set

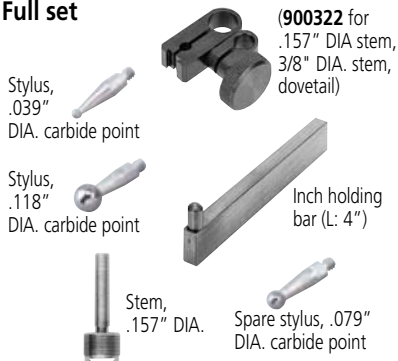

Basic set

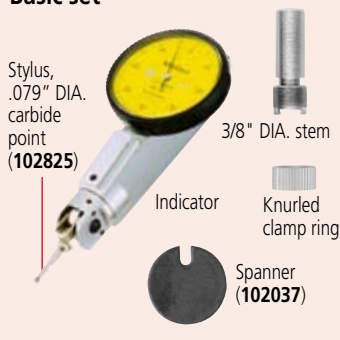

Optional Accessories

- : Swivel clamps (See page F-52.)
- : Holding bars (See page F-52.)
- : Stems (See page F-52.)
- 102824:** Stylus, ø1mm ball contact (carbide)
- 102825:** Stylus, ø2mm ball contact (carbide)
- 102826:** Stylus, ø3mm ball contact (carbide)

FEATURES

- Universal application to all directions. (Not only the direction of the measuring point, but also the direction of measurement itself can be adjusted 360 degrees without moving the indicator.)

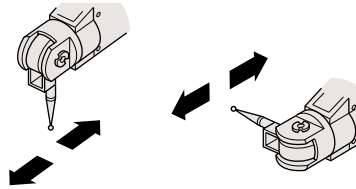

513-304GE

SPECIFICATIONS

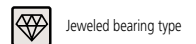

Metric

Graduation	Order No.		Range	Accuracy	Dial reading	Measuring force	Jeweled bearing type						
	Basic set	Full set											
0.01mm	513-304GE	513-304GT	0.8mm	8µm	0-40-0	0.3N or less	✓	—	—	—	—	—	—

Inch

Graduation	Order No.		Range	Accuracy	Dial reading	Measuring force	Jeweled bearing type						
	Basic set	Full set											
.0005"	513-302G	513-302GT	.03"	±.0005"	0-15-0	0.3N or less	✓	—	—	—	—	—	—

DIMENSIONS

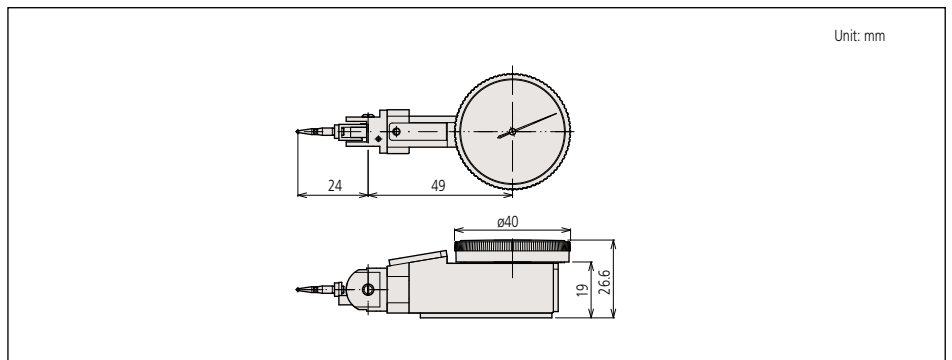

Unit: mm

Pocket Type Dial Test Indicator

SERIES 513

FEATURES

- Jeweled bearings assure higher sensitivity and accuracy.
Indicator can be mounted by clamping the stem or the body (except for 513-517WE and 513-517WT).
- Reversible measuring direction.
- Two holding bars are supplied. (Full sets only.)
- Fully adjustable bezel/dial face.
- Stylus is adjustable within 220°.
- Bezel is sealed with an O-ring to keep out water / oil.



513-518E



513-528E



513-512



513-504



513-517



513-515



513-514



513-503



513-501

Optional Accessories

- : Swivel clamps (See page F-53.)
- : Holding bars (See page F-53.)
- : Stems (See page F-53.)
- : Styli (See page F-53.)



Long stylus type



Jeweled bearing type



Dustproof type



Compact type

Set Configuration: Metric

Full set

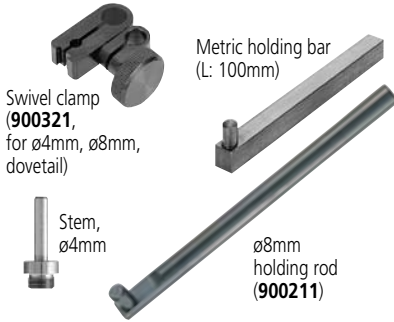

Basic set

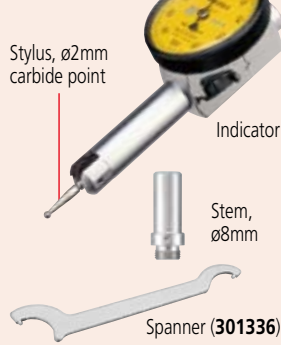

Set Configuration: Inch

Full set

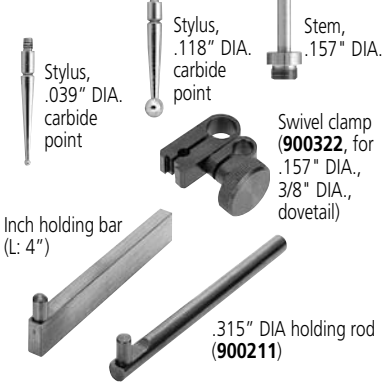

Basic set

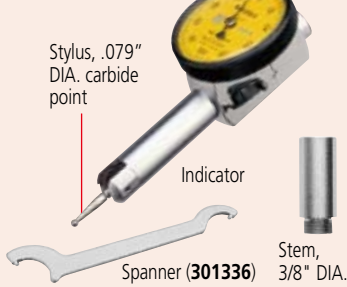

SPECIFICATIONS

Metric

Graduation	Order No.		Range	Accuracy	Dial reading	Measuring force					—	—
	Basic set	Full set										
0.01mm	513-514E	513-514T	0.5mm	10µm	0-25-0	0.3N or less	✓	✓	—	—	—	—
0.01mm	513-517E	513-517T	0.8mm	8µm	0-40-0	0.3N or less	—	✓	—	—	—	—
0.01mm	513-517WE	513-517WT	0.8mm	8µm	0-40-0	0.3N or less	—	✓	✓	—	—	—
0.01mm	513-527E	513-527T	0.8mm	8µm	0-40-0	0.3N or less	—	✓	—	✓	—	—
0.01mm	—	513-515T	1mm	10µm	0-50-0	0.3N or less	✓	✓	—	—	—	—
0.002mm	513-503E	513-503T	0.2mm	3µm	0-100-0	0.3N or less	—	✓	—	—	—	—
0.001mm	513-501E	513-501T	0.14mm	3µm	0-70-0	0.4N or less	—	✓	—	—	—	—

Inch

Graduation	Order No.		Range	Accuracy	Dial reading	Measuring force					—	—
	Basic set	Full set										
.001"	513-518	513-518T	.04"	±.001"	0-20-0	0.3N or less	—	✓	—	—	—	—
.001"	513-528	513-528T	.04"	±.001"	0-20-0	0.3N or less	—	✓	✓	—	—	—
.0005"	513-512	513-512T	.02"	±.0005"	0-10-0	0.3N or less	✓	✓	—	—	—	—
.0001"	513-504	513-504T	.01"	±.0002"	0-5-0	0.3N or less	—	✓	—	—	—	—

DIMENSIONS

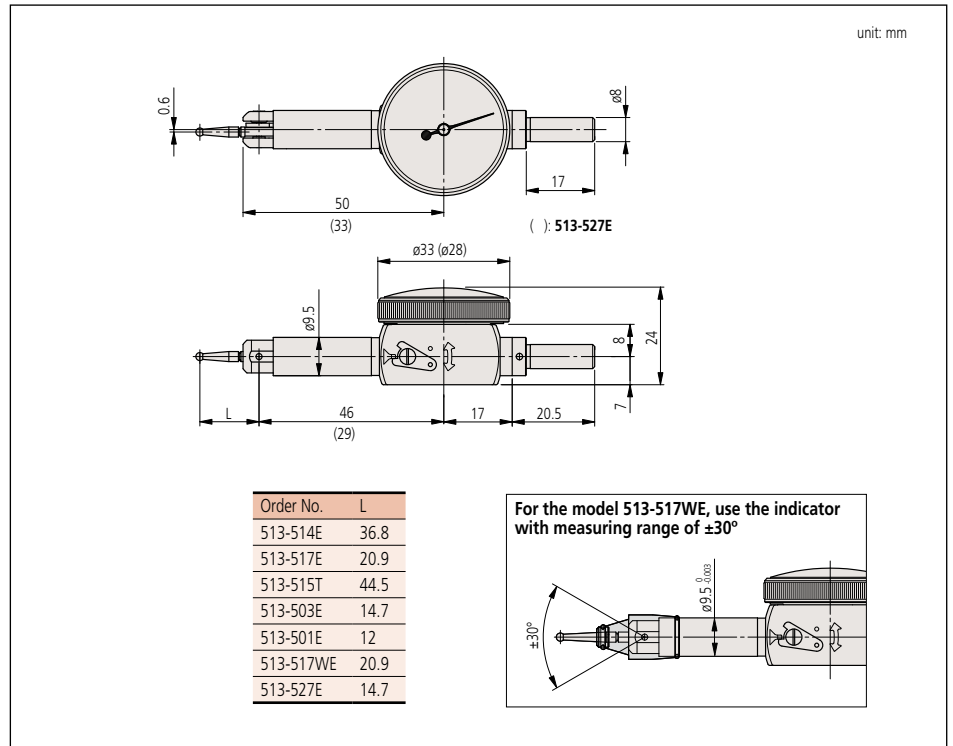

Styli, Stems and Holders

Optional Accessories for Dial Test Indicators

Styli (for Metric Models Only*)

* Except for universal type dial test indicator (513-304G).

- Stylus length affects the scale factor of an indicator. The styli provided as standard give a scale factor of unity.

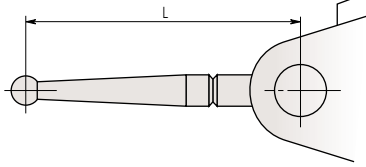

ø0.5mm ball-point



190547 (L=14.7mm)
190549 (L=20.9mm)
190654 (L=22.3mm)
190656 (L=44.5mm)

ø0.7mm ball-point



190548 (L=14.7mm)
190550 (L=20.9mm)
190653 (L=22.3mm)
190655 (L=44.5mm)

ø1mm ball-point (Carbide)



21CZA044 (L=12.8mm)
103017 (L=14.7mm)
103013 (L=20.9mm)
137558 (L=22.3mm)
137746 (L=36.8mm)
136235 (L=44.5mm)

ø2mm ball-point (Carbide)



21CZA036 (L=12.8mm)
103010 (L=14.7mm)
103006 (L=20.9mm)
137557 (L=22.3mm)
129949 (L=36.8mm)
136013 (L=44.5mm)

ø2mm ball-point (Ruby)



21CZA212 (L=12.8mm)
21CZA209 (L=14.7mm)
21CZA201 (L=20.9mm)

ø3mm ball-point (Carbide)



21CZA045 (L=12.8mm)
103018 (L=14.7mm)
103014 (L=20.9mm)
137559 (L=22.3mm)
137747 (L=36.8mm)
136236 (L=44.5mm)

Spanner



102037

Stems with Knurled Clamp Ring

ø4mm (.157" DIA.)



902802

ø8mm



902804

3/8" DIA.



902805

Swivel Clamps

- Can be used with Holding Bars.

For ø4mm stem, ø8mm stem, and dovetail



900321

For .157" DIA. stem, 3/8" DIA. stem, and dovetail



900322

Holding Bars



9 x 9mm

953638 (Length: 50mm)
900209 (Length: 100mm)



ø8mm (.315" DIA)

900211 (Length: 115mm/ 4.528")



.25" x .5"

953639 (Length: 2")
900306 (Length: 4")

Universal Holder

- Allows the indicator to be set at the desired attitude to the workpiece.



901916 (ø8mm stem)
901459 (.25" DIA. stem)
901461 (ø6mm stem)

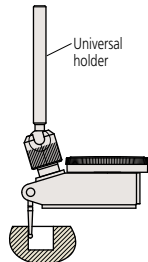

Universal holder

Spanner

Stems with Knurled Clamp Ring

ø4mm (.157" DIA.)



902802

ø8mm



902804

3/8" DIA.



902805

Centering Holder

- Allows large diameter cylinders or holes to be centered on a machine tool.



901959 (ø8mm stem)
901997 (.25" DIA. stem)

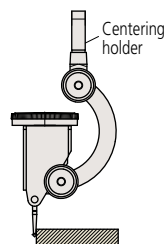

Centering holder

Styli, Stems and Holders

Optional Accessories for Pocket Type Dial Test Indicators

Styli (for Metric Models Only)

- Stylus length affects the scale factor of an indicator. The styli provided as standard give a scale factor of unity.

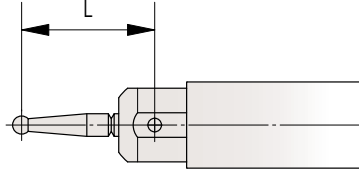

ø0.5mm ball-point



190547 (L=14.7mm)
190549 (L=20.9mm)
190656 (L=44.5mm)

ø0.7mm ball-point



190548 (L=14.7mm)
190550 (L=20.9mm)
190655 (L=44.5mm)

ø1mm ball-point (Carbide)



136756 (L=12.1mm)
103017 (L=14.7mm)
103013 (L=20.9mm)
136235 (L=44.5mm)

ø2mm ball-point (Carbide)



136104 (L=12.1mm)
103010 (L=14.7mm)
103006 (L=20.9mm)
136013 (L=44.5mm)

ø2mm ball-point (Ruby)



21CZA209 (L=14.7mm)
21CZA201 (L=20.9mm)

ø3mm ball-point (Carbide)



136758 (L=12.1mm)
103018 (L=14.7mm)
103014 (L=20.9mm)
136236 (L=44.5mm)

Stems

ø4mm (.157" DIA.)



102389

ø8mm



102822

3/8" DIA.



102081

Swivel Clamps

- Can be used with Holding Bars.

For ø4mm stem
and ø8mm stem, and
dovetail



900321

For .157" DIA. stem and
3/8" DIA. stem, and
dovetail



900322

Holding Bars



9 x 9mm

953638 (Length: 50mm)
900209 (Length: 100mm)



ø8mm (.315" DIA)

900211 (Length: 115mm)



.25" x .5"

953639 (Length: 2")
900306 (Length: 4")

Spanner



301336

Universal Holder

- Allows the indicator to be set at the desired attitude to the workpiece.



901917 (ø8mm stem)
901546 (.25" DIA. stem)
901547 (ø6mm stem)

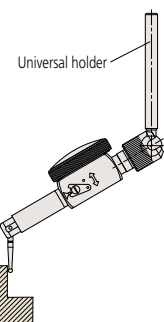

i-Checker

SERIES 170

FEATURES

The i-Checker is specially designed to calibrate dial indicators, dial test indicators, and other electronic comparison gage heads with a stroke of up to 100mm (4").

- $\pm(0.2+L/100)\mu\text{m}$ indication accuracy.
- Directly inspects an indicator with a stroke of up to 100mm (4"). The dial test indicator, bore gage and lever-type inductive head can be inspected with optional accessories.

- Adjustment of the measurement position is very easily accomplished because of semi-automatic measurement and fully automatic measurement functions.
- Creates and prints out a simple inspection certificate.
- Saves inspection results as a CSV file for analysis by software.



SPECIFICATIONS

Order No.*	Remarks
170-302	with $\varnothing 8\text{mm}$ bush
170-303	with $\varnothing 3/8"$ bush
170-302-01	with $\varnothing 8\text{mm}$ bush and calibration certificate
170-303-01	with $\varnothing 3/8"$ bush and calibration certificate

* To denote your AC power cable add the following suffixes to the order No.: **A** for UL/CSA, **D** for CEE, **E** for BS, **K** for EK, **No suffix** is required for JIS/100V

DIMENSIONS

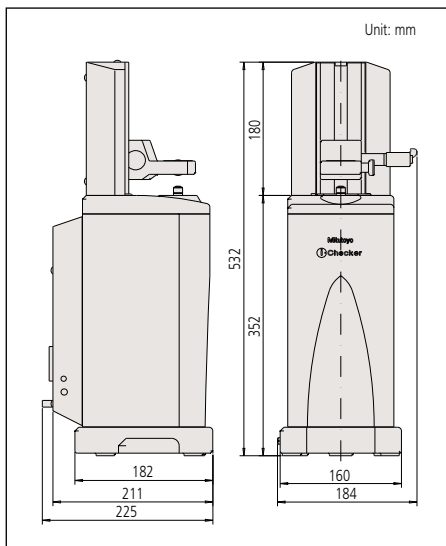

Applicable Indicators

- Dial indicator
- Hicator
- Digimatic indicator***
- Test indicator*
- Bore gage**
- Linear gage

* requires optional test indicator attachment set

** requires optional bore gage accessory

*** requires optional SPC cable for fully automatic measurement



Using test indicator attachment set (02ASK000)



Using bore gage accessory set (02ASK110)



(Refer to page IX for details.)

Technical Data

Measuring Range: 100mm/4"
 Resolution: 0.02 μm /0.8 μin
 Accuracy: $\pm(0.2+L/100)\mu\text{m}$ in vertical position
 (at 20°C) $\pm(0.3+2L/100)\mu\text{m}$ in lateral position
 L = arbitrary length (mm)
 Drive method: Electric motor
 Measuring Unit: Reflective-type glass linear encoder
 Thermal expansion coefficient: $(8\pm 1)\times 10^{-6}/\text{K}$
 Measurement method: Semi-automatic / Fully automatic*
 Dimensions: 184 x 225 x 532mm (W x D x H)
 Operating temperature range: 20°C \pm 3°C
 Power supply: 100VAC to 240VAC \pm 10%, 50/60Hz
 Mass: 20kg/44.1lbs

* Automatic measurement requires the indicator's connection cable. Additionally some form of indicator, along with a connecting machine (the optional accessory for indicator as a Digimatic power-supply unit on EF counter) will be needed.

Functions

Inspect your analog indicator semi-automatically!

The pointer of the analog indicator is positioned just before the measuring point automatically via Mitutoyo's Semi-automatic Measurement function. After that, inspection begins simply by adjusting the pointer position with the jog-dial. Because of this function, measurement time is reduced and user fatigue is practically eliminated. Additionally all functions necessary for inspection are combined in the control box so that the operator need not rely on excessive eye movement to adjust the pointer.

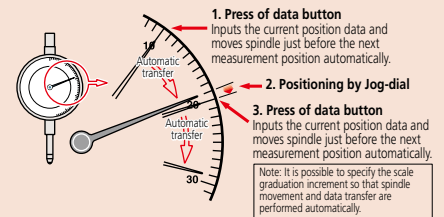

Fully automatic inspection of digital indicator

The Automatic Measurement function, in tandem with a digital indicator makes the spindle move so that measurement data is acquired automatically. Therefore, manual adjustment to the measurement position is unnecessary and the efficiency of every inspection is enhanced.



Create and printout a simplified inspection certificate

It is possible to create, edit and print out your own inspection certificate. Furthermore, that data can be saved as a CSV file.

Optional Accessories

- 02ASK000: Test indicator attachment set ($\varnothing 6\text{mm}$ stem)
- 02ASK180: Test indicator attachment set ($\varnothing 8\text{mm}$ stem)
- 02ASK370: Test indicator holder ($\varnothing 6\text{mm}$ stem)
- 02ASK380: Test indicator holder ($\varnothing 8\text{mm}$ stem)
- 02ASK110: Bore gage accessory set
- 02ASL310: Accessory for Bore gages
- 902803: $\varnothing 6\text{mm}$ dovetail grooved stem
- 902804: $\varnothing 8\text{mm}$ dovetail grooved stem
- 02ASK040: Stem bush $\varnothing 6\text{mm}$
- 02ASJ856: Stem bush $\varnothing 8\text{mm}$
- 02ASK150: Stem bush $\varnothing 8\text{mm}$, short
- 02ASL150: Stem bush $\varnothing 10$, short
- 02ASK050: Bush $\varnothing 9.5$ (Requires 02ASK070)
- 02ASK060: Stem bush $\varnothing 12\text{mm}$
- 02ASK070: Stem bush $\varnothing 15\text{mm}$
- 02ASK080: Stem bush $\varnothing 20\text{mm}$
- 02ASK710: Stem bush $\varnothing 28\text{mm}$
- 02ASK090: Stem bush $3/8"$
- 02ASK130: Stem bush case
- 02ASK730: Reflector
- 931797: Foot switch

UDT-2 Dial Gage Tester

SERIES 170

The UDT-2 Dial Gage Tester consists of a specially designed 25mm micrometer head with a large-diameter graduated scale and rigid holding fixtures. 0.001mm graduations make the UDT-2 highly suitable for calibrating 1mm, 5mm, 10mm, and 20mm range, 0.01mm reading, dial indicators and dial test indicators.

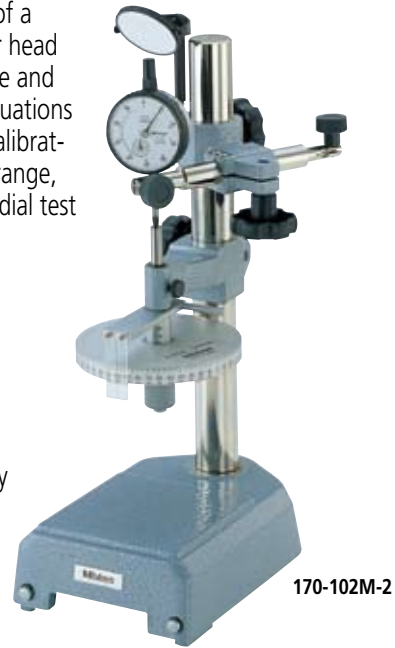

170-102M-2

FEATURES

- Clamping stem diameter—
170-102M-2: 6mm and 8mm,
170-101E: .25" and .375"
- With the optional stand (951498), inspection of Dial Bore Gages is very comfortable to perform.

SPECIFICATIONS

Metric			
Range	Order No.	Graduation	Accuracy
0 - 25mm	170-102M-2	0.001mm	±2µm

Inch			
Range	Order No.	Graduation	Accuracy
0 - 1"	170-101E	.0001"	±.0001"



(Refer to page IX for details.)

Optional Accessory

951498: Stand for bore gage inspection



Calibration Tester

SERIES 521

The Calibration Tester is specially designed to calibrate short range dial indicators, dial test indicators, and other electronic comparison gage heads.

FEATURES

- Universal bracket accepts any dial indicator, dial test indicator, lever head of Mu-Checker without any additional accessory.
- Clamping capacity: ø4mm - ø10mm
- Dual color-coded directional graduations to facilitate measurements.



521-103

SPECIFICATIONS

Metric			
Range	Order No.	Graduation	Accuracy
0 - 1mm	521-103	0.0002mm	±0.2µm
0 - 5mm	521-105	0.0002mm	±0.8µm

Inch			
Range	Order No.	Graduation	Accuracy
0 - .05"	521-104	.00001"	±.00001"
0 - .2"	521-106	.00001"	±.00003"



(Refer to page IX for details.)



Calibrating test indicator

Thickness Gages

SERIES 547, 7

Thickness Gages offer a quick and efficient means of inspection with their convenient grip handle, thumb trigger and spring-loaded spindle. The various models cover a wide range of applications.

FEATURES

- Wide range of applications with various types of measuring faces (on the spindle and anvil).

- The digital models incorporate Mitutoyo's popular ID-C and ID-S Series Digimatic Indicators to provide error-free LCD readings as well as data output for SPC analysis.
- **547-401 (547-400)** is ideally suited for measuring thicknesses of paper, film, wire, sheet metal and similar materials.

Standard Type / Digital



Deep Throat Type / Digital



Standard Type / Dial



Deep Throat Type / Dial



High Accuracy Type / Digital



DIMENSIONS

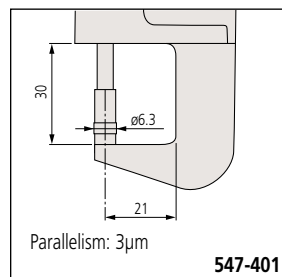

(Refer to page IX for details.)

Technical Data of Digital Models

Accuracy: Refer to the list of specifications (excluding quantizing error)

Resolution:

0.01mm type	0.01mm
0.001mm type	0.001mm/0.001mm
.0005"/0.01mm type	.0005"/0.01mm
.00005"/0.001mm type	.0005"/.0001"/.00005"/0.01mm/0.001mm

Display: LCD

Scale type: ABSOLUTE electrostatic linear encoder

Max. response speed: Unlimited

Measuring force: Refer to the list of specifications

Stem dia.: 8mm (ISO/JIS type) or 3/8" (ANSI/AGD type)

Contact point: Carbide ball with M2.5x0.45 (ISO/JIS type)
Carbide ball with #4-48UNF (ANSI/AGD type)

Battery: SR44 (1 pc.), **938882**

Battery life: Approx. 7,000 hours under normal use

Dust/Water protection level: IP42 or IP53 (dust-proof type)

Functions of Digital Models

Origin-set/Preset, Zeroset, GO/±NG judgment, Counting direction switching, Power ON/OFF, Simplified calculation, Function lock, Data hold, Data output, inch/mm conversion (inch/mm models)

Alarm: Low voltage, Counting value composition error, Overflow error, Tolerance limit setting error

Optional Accessories

- 905338:** SPC cable (1m) for digital models
 - 905409:** SPC cable (2m) for digital models
 - 02AZD790F:** SPC cable for U-WAVE (160mm)
 - 902011:** Spindle lifting lever (ISO/JIS type)*
 - 902794:** Spindle lifting lever (ANSI/AGD type)*
 - 137693:** Spindle lifting hook**
 - 540774:** Spindle lifting cable
 - 125317:** Spare rubber boot (for dust-proof type)
 - 02ACA571:** Auxiliary spindle spring for 25mm/1" models***
 - 02ACA773:** Auxiliary spindle spring for 50mm/2" models***
- : Backs (See page F-40.)
- : Contact points (See page F-36.)

*Can be used on 12mm/5" models only.
**Can be used on 25mm/1" or 50mm/2" models.
***Required when orienting the indicator upside down.

DIMENSIONS

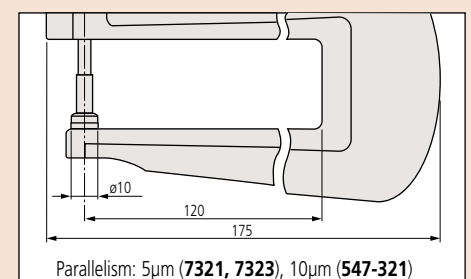
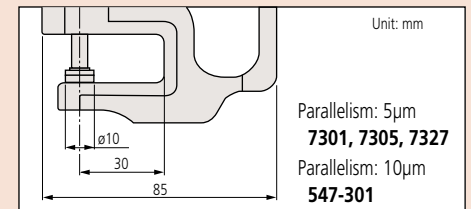

DIMENSIONS

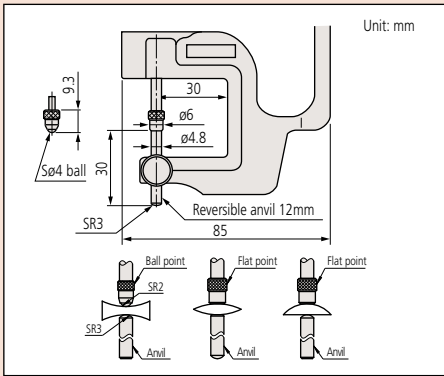

Lens thickness measurement



Tube thickness measurement



DIMENSIONS

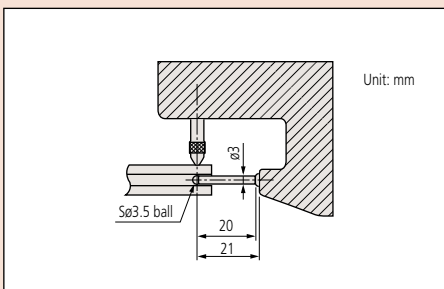

DIMENSIONS

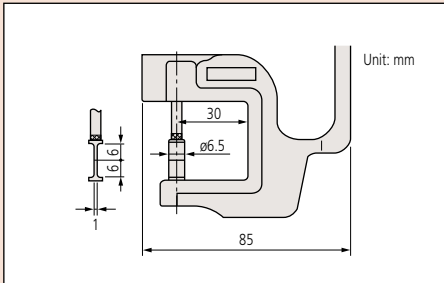

Groove depth measurement



SPECIFICATIONS

Metric	Digital Type
Range	Order No. Resolution
0 - 12mm	547-401 0.001mm
0 - 10mm	547-301 0.01mm
0 - 10mm	547-321 0.01mm
0 - 10mm	547-313 0.01mm
0 - 10mm	547-315 0.01mm
0 - 10mm	547-360 0.01mm

Inch/Metric	Digital Type	Accuracy	Measuring force	Remarks
0 - .47"	547-400S /	±3µm	3.5N or less	High accuracy, carbide spindle/anvil
0 - .4" / 0 - .47"*	547-300S / 547-500*	±20µm	1.5N or less	Standard, ceramic spindle/anvil
0 - .4" / 0 - .47"*	547-320S / 547-520*	±20µm	1.5N or less	Deep throat, ceramic spindle/anvil
0 - .4" / 0 - .47"*	547-312S / 547-512*	±20µm	1.5N or less	Lens thickness
0 - .4" / 0 - .47"*	547-316S / 547-516*	±20µm	1.5N or less	Groove depth
0 - .4" / 0 - .47"*	547-361S / 547-561*	±20µm	1.5N or less	Tube thickness

*using ID-S Digimatic indicator, Standard model with .0001"/0.001mm resolution ID-S is available (**547-526**).

Metric	Dial Type
Range	Order No. Dial reading
0 - 1mm	7327 0.001mm
0 - 10mm	7301 0.01mm
0 - 20mm	7305 0.01mm
0 - 10mm	7321 0.01mm
0 - 20mm	7323 0.01mm
0 - 10mm	7313 0.01mm
0 - 10mm	7315 0.01mm
0 - 10mm	7360 0.01mm

Inch	Dial Type	Accuracy	Measuring force	Remarks
0 - .05"	7326S .00005"	±5µm	1.4N or less	Fine dial reading, ceramic spindle/anvil
0 - .5"	7300S .001"	±15µm	1.4N or less	Standard, ceramic spindle/anvil
0 - 1"	7304S .001"	±20µm	2.0N or less	Standard, ceramic spindle/anvil
—	—	±15µm	1.4N or less	Deep throat, ceramic spindle/anvil
0 - 1"	7322S .001"	±22µm	2.0N or less	Deep throat, ceramic spindle/anvil
0 - .5"	7312S .001"	±15µm	1.4N or less	Lens thickness
0 - .5"	7316S .001"	±15µm	1.4N or less	Groove depth
0 - .5"	7361S .001"	±15µm	1.4N or less	Tube thickness

Lightweight Dial Thickness Gage

SERIES 7



Ceramic spindle/
anvil

7331S

Application

Measuring paper thickness



Measuring thickness of a human hair



SPECIFICATIONS

Metric

Range	Order No.	Dial reading	Accuracy	Measuring force
0 - 10mm	7331S	0.01mm	±20µm	1.4N or less

DIMENSIONS

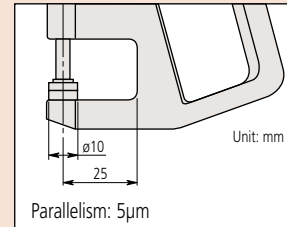

Pocket Thickness Gage

SERIES 7

A very compact thickness gage is designed for carrying convenience and is ideally suited for quick inspection of paper, leather, wire, plastic, sheet metal and similar materials. The spindle is pre-loaded to provide a constant measuring force (2N or less).

FEATURES

- Measuring faces are hardened, ground and lapped for accuracy.
- Easy zero-point adjustment.

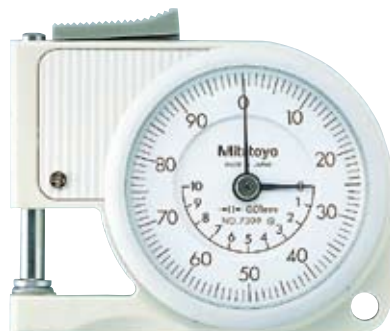

7309

SPECIFICATIONS

Metric

Range	Order No.	Dial reading	Accuracy
0 - 10mm	7309	0.01mm	±20µm

Inch

Range	Order No.	Dial reading	Accuracy
0 - .4"	7308	.001"	±.001"

DIMENSIONS

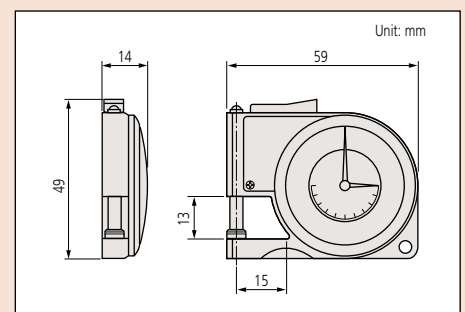



Digimatic Caliper Gage

SERIES 209 — Internal, External and Tube Thickness Measurement Type

Versatile internal and external measuring gages for hole diameter, groove depth, tube thickness, and hard-to-reach dimensions.

The Digimatic Caliper Gages provide error-free LCD readings as well as data output for SPC analysis.

Technical Data

Accuracy: Refer to the list of specifications (excluding quantizing error)
 Resolution: 0.01mm or 0.005mm
 Display: LCD
 Stem dia.: 8mm (ISO/JIS type) or 3/8" (ANSI/AGD type)
 Contact points: Carbide ball with M2.5x0.45 (ISO/JIS type)
 Steel ball with #4-48UNF (ANSI/AGD type)
 Battery: CR-123A or DL-123A (1 pc.)
 Battery life: Approx. 350 hours
 Dust/Water protection level: IP63

Functions

Zerose, Preset, Auto power OFF, Data hold, Max/Min value holding, Data output

Optional Accessories

21JAA300: SPC cable (2m)

Internal measurement type



209-506M

Unit: mm

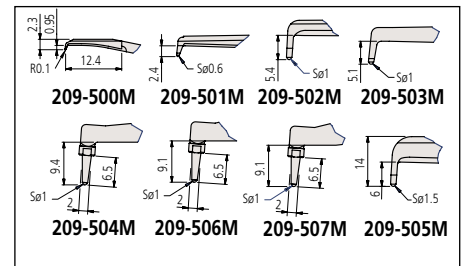

External measurement type



209-521M

Unit: mm

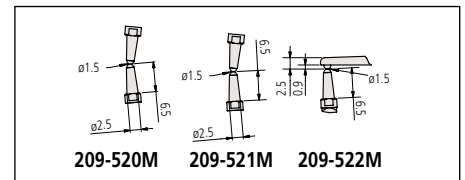

SPECIFICATIONS

Metric

Range	Order No.	Resolution	Accuracy	Measuring force	Dimension (L)	Remarks
2.5 - 12.5mm	209-500M	0.005mm	±15µm	0.7 - 1.2N	12mm	Internal measurement type
5 - 25mm	209-501M	0.01mm	±20µm	0.9 - 1.4N	22mm	Internal measurement type
10 - 30mm	209-502M	0.01mm	±20µm	0.9 - 1.4N	47mm	Internal measurement type
20 - 40mm	209-503M	0.01mm	±20µm	1.1 - 1.7N	50mm	Internal measurement type
30 - 50mm	209-504M	0.01mm	±20µm	1.1 - 1.7N	55mm	Internal measurement type
15 - 55mm	209-505M	0.02mm	±40µm	1.2 - 1.7N	120mm	Internal measurement type
50 - 70mm	209-506M	0.01mm	±20µm	1.1 - 1.7N	55mm	Internal measurement type
70 - 90mm	209-507M	0.01mm	±20µm	1.1 - 1.7N	55mm	Internal measurement type
0 - 10mm	209-520M	0.005mm	±10µm	0.6 - 1.2N	10mm	External measurement type
0 - 20mm	209-521M	0.01mm	±20µm	0.7 - 1.3N	46mm	External measurement type
0 - 20mm	209-522M	0.01mm	±20µm	0.7 - 1.3N	46mm	External measurement type

DIMENSIONS

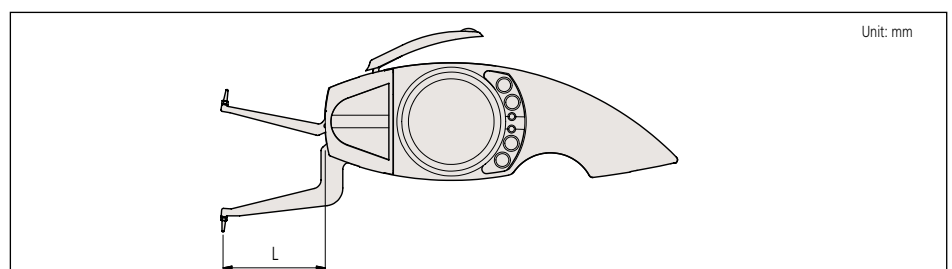

Unit: mm

Dial Caliper Gage

SERIES 209 — Internal Measurement Type

These Dial Caliper Gages are comparison gages, and should be used in conjunction with a Setting Ring or a micrometer. The

caliper is spring loaded and makes point contact at constant measuring force.



209-152



209-122

SPECIFICATIONS

Metric								
Range	Order No.	Graduation	Dial face	Accuracy	Measuring force	Dimension [L / A (max) / B (min)]		
6 - 18mm	209-122	0.01mm	0-100-100	±40µm	1.2N or less	40mm	1.0mm	2.5mm
10 - 22mm	209-123	0.01mm	0-100-100	±40µm	1.2N or less	40mm	2.0mm	2.5mm
20 - 32mm	209-124	0.01mm	0-100-100	±40µm	1.2N or less	40mm	4.2mm	2.5mm
5 - 15mm	209-152	0.01mm	0-100	±25µm	1.2N or less	30mm	2.0mm	0.7mm
10 - 20mm	209-153	0.01mm	0-100	±25µm	1.2N or less	30mm	5.0mm	0.7mm
10 - 30mm	209-171	0.01mm	0-100-100	±25µm	1.2N or less	65mm	5.2mm	0.7mm
20 - 40mm	209-172	0.01mm	0-100-100	±25µm	1.2N or less	65mm	9.5mm	0.7mm



209-650



209-608



209-609



209-884



209-896

SPECIFICATIONS

Metric								
Range	Order No.	Graduation	Accuracy	Measuring force	Contact point	Dimension [L / A (max) / B (min)]		
2.5 - 7.5mm	209-650	0.005mm	±15µm	1.7N or less	R0.1mm	12.4mm	0.7mm	0.6mm
5 - 10mm	209-651	0.005mm	±15µm	1.7N or less	ø0.6mm	27mm	2.3mm	1.9mm
5 - 15mm	209-652	0.01mm	±20µm	1.7N or less	ø0.6mm	23mm	2.3mm	1.7mm
10 - 20mm	209-653	0.01mm	±20µm	1.7N or less	ø1.0mm	60.6mm	4.5mm	1.8mm
10 - 30mm	209-608	0.01mm	±30µm	1.5N or less	ø1.0mm	80mm	5.0mm	1.7mm
20 - 30mm	209-654	0.01mm	±20µm	1.7N or less	ø1.0mm	60.6mm	4.5mm	2.0mm
20 - 40mm	209-609	0.01mm	±30µm	1.5N or less	ø1.0mm	80mm	6.5mm	2.3mm
30 - 40mm	209-655	0.01mm	±20µm	1.7N or less	ø1.0mm	60.6mm	4.5mm	2.0mm
30 - 50mm	209-600	0.01mm	±30µm	1.5N or less	ø1.0mm	80mm	6.5mm	2.5mm
40 - 50mm	209-656	0.01mm	±20µm	1.7N or less	ø1.0mm	60.6mm	4.5mm	1.8mm
40 - 60mm	209-884	0.01mm	±30µm	1.5N or less	ø1.0mm	80mm	9.0mm	2.3mm
50 - 70mm	209-885	0.01mm	±30µm	1.5N or less	ø1.0mm	80mm	8.0mm	3.7mm
60 - 80mm	209-886	0.01mm	±30µm	1.5N or less	ø1.0mm	80mm	8.0mm	3.7mm
70 - 90mm	209-887	0.01mm	±30µm	1.5N or less	ø1.0mm	80mm	8.0mm	3.7mm
80 - 100mm	209-888	0.01mm	±30µm	1.5N or less	ø1.0mm	80mm	8.0mm	3.7mm
15 - 65mm	209-896	0.05mm	±50µm	2.0N or less	ø1.5mm	175mm	5.0mm	2.1mm
40 - 90mm	209-897	0.05mm	±50µm	2.0N or less	ø2.0mm	175mm	10.0mm	3.8mm
70 - 120mm	209-898	0.05mm	±50µm	2.0N or less	ø2.0mm	175mm	8.0mm	3.8mm

DIMENSIONS

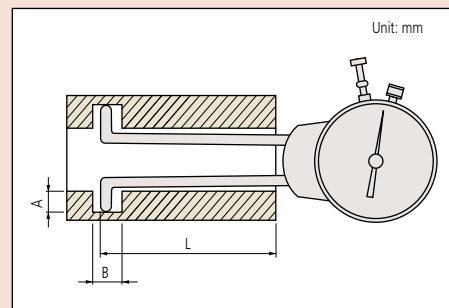

DIMENSIONS

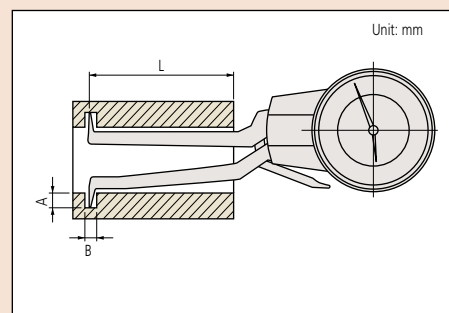

Dial Caliper Gage

SERIES 209 — External Measurement Type

Application

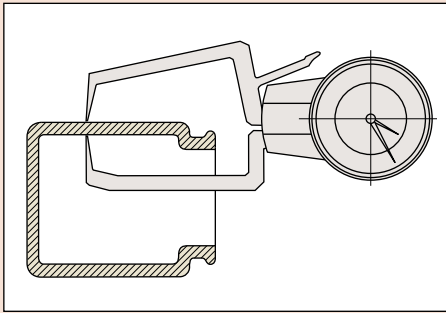

Type of Contact Points

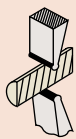

Upper / Lower contact point
209-660: R0.4 / R0.4
209-605: R0.5 / R0.5
209-610: R0.75 / R0.75

No. 1

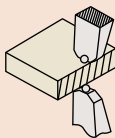

Upper / Lower contact point
209-602: $\phi 2.0$ / $\phi 2.0$ ball
209-601: $\phi 1.5$ / $\phi 1.5$ ball

No. 2

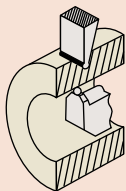

Upper / Lower contact point
209-606: R0.5 / $\phi 1.5$ ball
209-662: R0.4 / $\phi 1.5$ carbide ball

No. 3

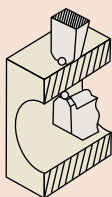

Upper / Lower contact point
209-607: $\phi 1.5$ / $\phi 1.5$ ball
209-661: $\phi 1.5$ / $\phi 1.5$ carbide ball

No. 4

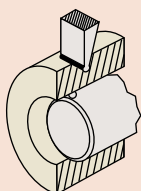

Upper / Lower contact point
209-611: R0.75 / $\phi 2$ ball

No. 5

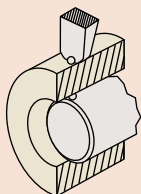

Upper / Lower contact point
209-604: $\phi 2$ / $\phi 2.5$ ball

No. 6

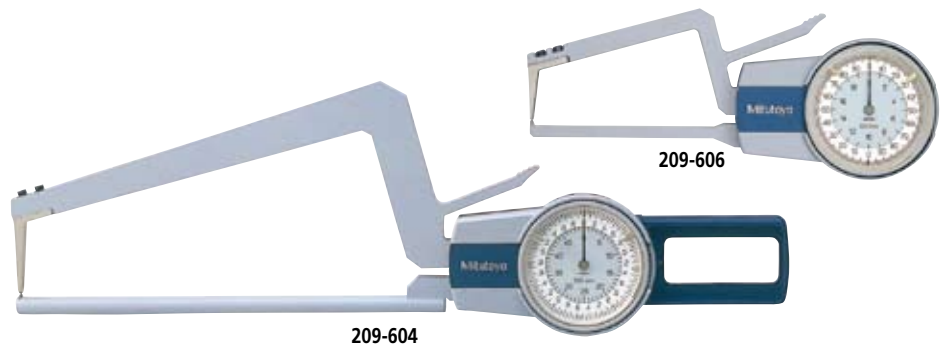

DIMENSIONS

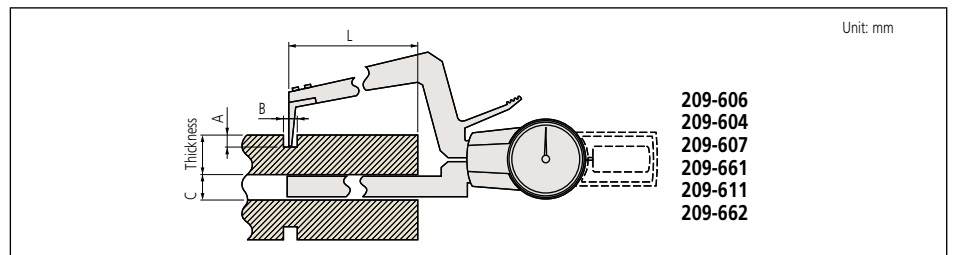

DIMENSIONS

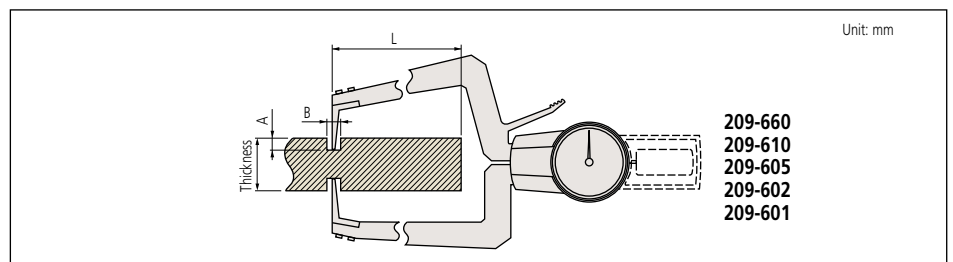

SPECIFICATIONS

Metric						
Range	Order No.	Graduation	Accuracy	Measuring force	Contact point	Dimension [L / A (max) / B (min) / C (min)]
0 - 10mm	209-660	0.01mm	$\pm 20\mu\text{m}$	1.3N or less	No. 1	60.5mm 7mm 2mm —
0 - 10mm	209-661	0.01mm	$\pm 20\mu\text{m}$	1.3N or less	No. 4	60.5mm 7mm 2mm 3mm
0 - 10mm	209-662	0.01mm	$\pm 20\mu\text{m}$	1.3N or less	No. 3	60.5mm 7mm 2mm 3mm
0 - 20mm	209-605	0.01mm	$\pm 30\mu\text{m}$	1.5N or less	No. 1	80mm 10mm 5mm —
0 - 20mm	209-601	0.01mm	$\pm 30\mu\text{m}$	1.5N or less	No. 2	80mm 10mm 5mm —
0 - 20mm	209-606	0.01mm	$\pm 30\mu\text{m}$	1.5N or less	No. 3	80mm 10mm 5mm 10mm
0 - 20mm	209-607	0.01mm	$\pm 30\mu\text{m}$	1.5N or less	No. 4	80mm 10mm 5mm 10mm
0 - 50mm	209-610	0.05mm	$\pm 50\mu\text{m}$	1.8N or less	No. 1	170mm 20mm 7mm —
0 - 50mm	209-602	0.05mm	$\pm 50\mu\text{m}$	1.8N or less	No. 2	170mm 20mm 7mm —
0 - 50mm	209-611	0.05mm	$\pm 50\mu\text{m}$	1.8N or less	No. 5	170mm 20mm 7mm 12mm
0 - 50mm	209-604	0.05mm	$\pm 50\mu\text{m}$	1.8N or less	No. 6	170mm 20mm 7mm 12mm

Bench Gage

SERIES 547, 7

FEATURES

- Compact and inexpensive gaging unit that consists of a dial indicator and a bench stand.
- Suitable for inspecting small parts on the shop floor.
- Supplied with a $\phi 20\text{mm}$ workpiece rest.



7060

547-064

SPECIFICATIONS

Metric		Digital Type				
Range	Order No.	Resolution	Workpiece height	Accuracy	Measuring force	Remarks (contact point)
12mm	547-064	0.01mm	25mm	$\pm 0.02\text{mm}$	1.5N or less	$\phi 6.3\text{mm}$ flat type

Inch/Metric		Digital Type				
Range	Order No.	Resolution	Workpiece height	Accuracy	Measuring force	Remarks (contact point)
.47"	547-066S	.0005"/0.01mm	1"	$\pm .001"$	1.5N or less	.25" DIA flat type

Metric		Dial Type				
Range	Order No.	Graduation	Workpiece height	Accuracy	Measuring force	Remarks (contact point)
10mm	7060	0.01mm	23mm	$\pm 0.015\text{mm}$	1.4N or less	$\phi 6.3\text{mm}$ flat type

DIMENSIONS

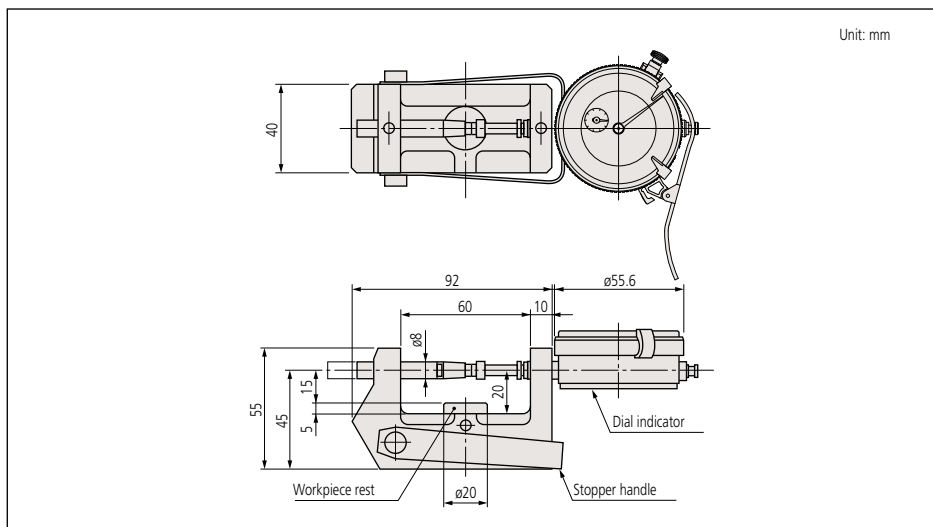

Unit: mm

SPC

ABSOLUTE[®]
Absolute System Patented by MITUTOYO

(Refer to page IX for details.)

Technical Data of Digital Models

Accuracy: Refer to the list of specifications (excluding quantizing error)
 Resolution: 0.01mm or .0005"/0.01mm
 Display: LCD
 Scale type: ABSOLUTE electrostatic linear encoder
 Max. response speed: Unlimited
 Contact point: $\phi 6.3\text{mm}$ flat type
 Measuring force: Refer to the list of specifications
 Battery: SR44 (1 pc.), **938882**
 Battery life: Approx. 5,000 hours under normal use

Functions of Digital Models

Origin-set/Preset, Zeroset, GO/ \pm NG judgment, Counting direction switching, Power ON/OFF, Simplified calculation, Function lock, Data hold, Data output, inch/mm conversion (inch/mm models)
 Alarm: Low voltage, Counting value composition error, Overflow error, Tolerance limit setting error

Optional Accessories

905338: SPC cable (1m) for digital models
905409: SPC cable (2m) for digital models
02AZD790F: SPC cable for U-WAVE (160mm)



ABSOLUTE
Absolute System Patented by MITUTOYO

(Refer to page IX for details.)

Technical Data of Digital Models

Accuracy: Refer to the list of specifications (excluding quantizing error)

0.01mm type 0.01mm
0.001mm type 0.001mm/0.001mm
.0005"/0.01mm type .0005"/0.01mm
.00005"/0.001mm type .00005"/.0001"/.00005"/0.01mm/0.001mm

Display: LCD
Scale type: ABSOLUTE electrostatic linear encoder
Max. response speed: Unlimited
Contact point: $\phi 3$ mm carbide flat type
(7051: $\phi 6$ mm flat type)

Measuring force: Refer to the list of specifications

Battery: SR44 (1 pc.), **938882**

Battery life: Approx. 7,000 hours under normal use

Functions of Digital Models

Origin-set/Preset, Zeroset, GO/ \pm NG judgment, Counting direction switching, Power ON/OFF, Simplified calculation, Function lock, Data hold, Data output, inch/mm conversion (inch/mm models)

Alarm: Low voltage, Counting value composition error, Overflow error, Tolerance limit setting error

Optional Accessories

905338: SPC cable (1m) for digital models

905409: SPC cable (2m) for digital models

02AZD790F: SPC cable for U-WAVE (160mm)

902190: $\phi 80$ mm large diameter anvil

903526: $\phi 50$ mm ceramic anvil

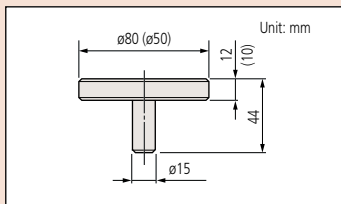

Upright Gage

SERIES 547, 7

FEATURES

- Compact and inexpensive gaging unit that consists of a dial indicator and a stand in the basic version.
- The Digimatic version offers multiple functions including GO/ \pm NG judgment, and SPC data output.
- Suitable for inspecting small parts on the shop floor.
- Anvil size: 40mm or 50mm in diameter.



SPECIFICATIONS

Metric		Digital Type				
Range	Order No.	Resolution	Workpiece height	Accuracy	Measuring force	Remarks (type of anvil)
12mm	547-054	0.01mm	30mm	± 0.02 mm	1.5N or less	$\phi 40$ mm steel type
12mm	547-053	0.001mm	30mm	± 3 μ m	1.5N or less	$\phi 50$ mm ceramic type
12mm	547-055	0.001mm	30mm	± 3 μ m	1.5N or less	$\phi 40$ mm steel type

Inch/Metric		Digital Type				
Range	Order No.	Resolution	Workpiece height	Accuracy	Measuring force	Remarks (type of anvil)
.5"	547-034S	.0005"/0.01mm	1.2"	$\pm .001$ "	1.5N or less	1.57" DIA steel type
.5"	547-033S	.00005"/0.001mm	1.2"	$\pm .0001$ "	1.5N or less	1.97" DIA ceramic type
.5"	547-035S	.00005"/0.001mm	1.2"	$\pm .0001$ "	1.5N or less	1.57" DIA steel type

Metric		Dial Type				
Range	Order No.	Graduation	Workpiece height	Accuracy	Measuring force	Remarks (type of anvil)
10mm	7050	0.01mm	20mm	± 0.02 m	1.4N or less	$\phi 40$ mm steel type
10mm	7051	0.01mm	20mm	± 0.02 m	1.4N or less	$\phi 40$ mm steel type
10mm	7052	0.01mm	35mm	± 0.02 m	1.4N or less	$\phi 40$ mm steel type
1mm	7053	0.001mm	30mm	± 3 μ m	1.5N or less	$\phi 40$ mm steel type

Inch		Dial Type				
Range	Order No.	Graduation	Workpiece height	Accuracy	Measuring force	Remarks (type of anvil)
1"	7056	.001"	1"	$\pm .002$ "	1.4N or less	1.57" DIA steel type

DIMENSIONS

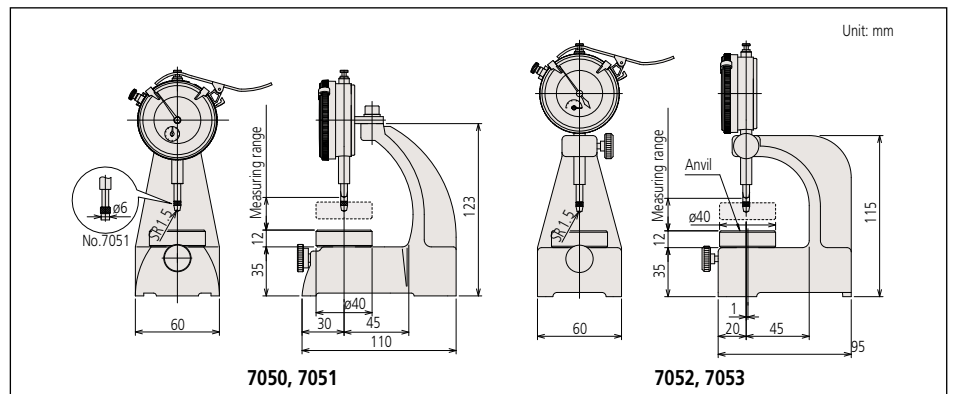

Dial Snap Gage

SERIES 201

FEATURES

- Designed for quick GO/NG judgment of diameters of cylinders and shafts in machining processes.
- Dial indicator is optional.
- Anvil retracting stroke: 2mm/.078"
- Anvil positioning range: 25mm/1"
- Wide (13.5 x 12mm/1.53 x .47"), flat carbide anvils.
- Both front edges of the anvil are chamfered for easy workpiece insertion.

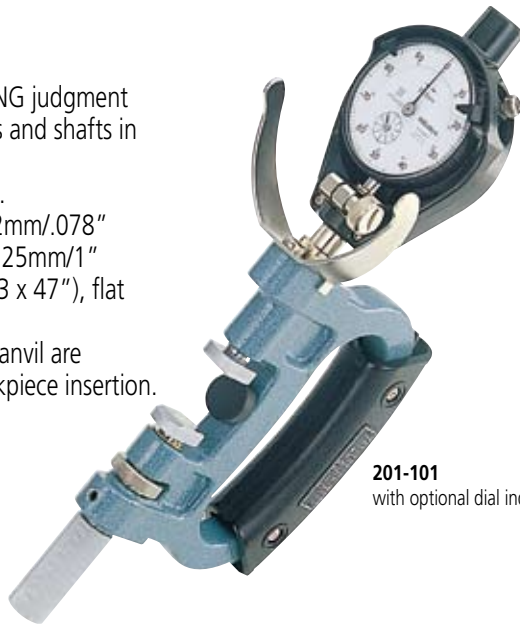

201-101
with optional dial indicator

Technical Data

Accuracy: Refer to the list of specifications
 Anvil retracting stroke: 2mm/.078"
 Anvil positioning range: 25mm/1"
 Anvil flatness: 1μm/.00004"

SPECIFICATIONS

Metric				
Range	Order No.	Parallelism	Measuring force	Recommended dial indicator (optional)
0 - 25mm	201-101	5μm or less	15N±3N	2046SB (0.01mm reading), 2109SB-10 (0.001mm reading)
25 - 50mm	201-102	5μm or less	15N±3N	2046SB (0.01mm reading), 2109SB-10 (0.001mm reading)
50 - 75mm	201-103	5μm or less	15N±3N	2046SB (0.01mm reading), 2109SB-10 (0.001mm reading)
75 - 100mm	201-104	5μm or less	15N±3N	2046SB (0.01mm reading), 2109SB-10 (0.001mm reading)
100 - 125mm	201-105	5μm or less	15N±3N	2046SB (0.01mm reading), 2109SB-10 (0.001mm reading)
125 - 150mm	201-106	5μm or less	15N±3N	2046SB (0.01mm reading), 2109SB-10 (0.001mm reading)
150 - 175mm	201-107	5μm or less	15N±3N	2046SB (0.01mm reading), 2109SB-10 (0.001mm reading)
175 - 200mm	201-108	5μm or less	15N±3N	2046SB (0.01mm reading), 2109SB-10 (0.001mm reading)
200 - 225mm	201-109	5μm or less	15N±3N	2046SB (0.01mm reading), 2109SB-10 (0.001mm reading)
225 - 250mm	201-110	5μm or less	15N±3N	2046SB (0.01mm reading), 2109SB-10 (0.001mm reading)
250 - 275mm	201-111	5μm or less	15N±3N	2046SB (0.01mm reading), 2109SB-10 (0.001mm reading)
275 - 300mm	201-112	5μm or less	15N±3N	2046SB (0.01mm reading), 2109SB-10 (0.001mm reading)

Inch				
Range	Order No.	Parallelism	Measuring force	Recommended dial indicator (optional)
0 - 1"	201-151	.00025" or less	15N±3N	2803SB-10 (.0001" reading)
1 - 2"	201-152	.00025" or less	15N±3N	2803SB-10 (.0001" reading)
2 - 3"	201-153	.00025" or less	15N±3N	2803SB-10 (.0001" reading)
3 - 4"	201-154	.00025" or less	15N±3N	2803SB-10 (.0001" reading)
4 - 5"	201-155	.00025" or less	15N±3N	2803SB-10 (.0001" reading)
5 - 6"	201-156	.00025" or less	15N±3N	2803SB-10 (.0001" reading)
6 - 7"	201-157	.00025" or less	15N±3N	2803SB-10 (.0001" reading)
7 - 8"	201-158	.00025" or less	15N±3N	2803SB-10 (.0001" reading)
8 - 9"	201-159	.00025" or less	15N±3N	2803SB-10 (.0001" reading)
9 - 10"	201-160	.00025" or less	15N±3N	2803SB-10 (.0001" reading)
10 - 11"	201-161	.00025" or less	15N±3N	2803SB-10 (.0001" reading)
11 - 12"	201-162	.00025" or less	15N±3N	2803SB-10 (.0001" reading)

DIMENSIONS

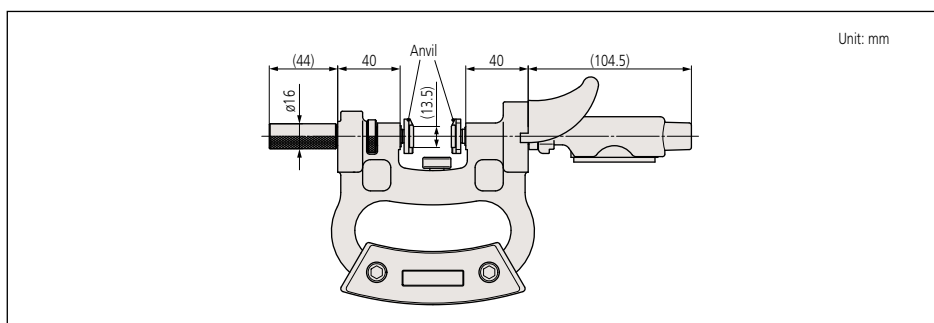

Female Screw Thread Comparator

SERIES 243

Application

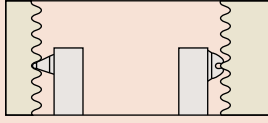

Optional Accessories

243-800: Interchangeable inserts set for Metric and Unified screws

0.4 - 0.5mm / 64 - 48TPI (**243-801**)

0.6 - 0.9mm / 44 - 28TPI (**243-802**)

1 - 1.75mm / 24 - 14TPI (**243-803**)

2 - 3mm / 13 - 9TPI (**243-804**)

3.5 - 5mm / 8 - 5TPI (**243-805**)

5.5 - 7mm / 4.5 - 3.5TPI (**243-806**)

243-810: Interchangeable inserts set for Whitworth screws

60 - 48TPI (**243-811**)

48 - 40TPI (**243-812**)

40 - 32TPI (**243-813**)

32 - 24TPI (**243-814**)

24 - 18TPI (**243-815**)

18 - 14TPI (**243-816**)

14 - 10TPI (**243-817**)

10 - 7TPI (**243-818**)

7 - 4.5TPI (**243-819**)

4.5 - 3.5TPI (**243-820**)

FEATURES

- Quick inspection of pitch diameters of female screw threads can be done by using interchangeable inserts (optional).
- Adjustable measuring jaws for a wide range of inside diameter comparison measurements.



243-102
(including dial indicator)

SPECIFICATIONS

Metric				
Range	Order No.	Graduation	Probe depth	Measuring force
25 - 100mm	243-101	0.01mm	20mm	7N±1N
25 - 200mm	243-102	0.01mm	25mm	7N±1N
25 - 300mm	243-103	0.01mm	30mm	7N±1N

DIMENSIONS

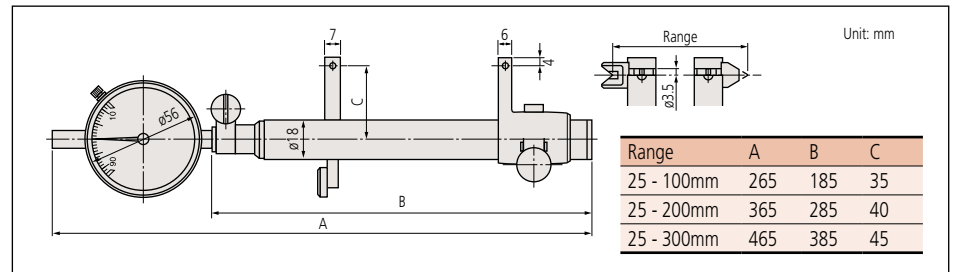

Roll Caliper

SERIES 310

FEATURES

- The Roll Caliper is the most widely used instrument for checking the diameter of rollers used in the manufacture of many products such as metal, rubber and paper.
- Performs fast and accurate comparison measurements of roller diameter with the roller still mounted on a machine tool.
- Various types of detectors (dial indicator,

Digitmatic indicator, Mu-Checker gage head, etc.) can be attached according to the required accuracy and workpiece size.



310-132
with optional dial indicator

SPECIFICATIONS

Metric		Inch	
Range	Order No.	Range	Order No.
ø500 - ø1400mm	310-131	ø20" - ø56"	310-141
ø400 - ø1050mm	310-132	ø16" - ø42"	310-142
ø275 - ø825mm	310-133	ø11" - ø32"	310-143
ø200 - ø600mm	310-134	ø8" - ø24"	310-144
ø100 - ø450mm	310-135	ø4" - ø17"	310-145

Contact Force Gage

SERIES 546

FEATURES

- Measures small forces applied to the end of its measuring lever in units of newtons (N).
- Contact Force Gages are widely used to determine the measuring force applied by

an instrument to a workpiece, as well as contact forces of electrical relays, micro-switches, valves and precision springs.

- Convenient peak-hold type gages are also available.



SPECIFICATIONS

Standard		
Minimum reading	Order No.	Range
2mN	546-112	6mN - 50mN
5mN	546-113	10mN - 100mN
10mN	546-114	30mN - 300mN
0.02N	546-115	0.06N - 0.5N
0.05N	546-116	0.1N - 1N
0.05N	546-117	0.15N - 1.5N
0.1N	546-118	0.3N - 3N
0.2N	546-119	0.6N - 5N

Peak hold		
Graduation	Order No.	Range
5mN	546-133	10mN - 100mN
10mN	546-134	30mN - 300mN
0.02N	546-135	0.06N - 0.5N
0.05N	546-136	0.1N - 1N
0.05N	546-137	0.15N - 1.5N
0.1N	546-138	0.3N - 3N
0.2N	546-139	0.6N - 5N

Application

Measuring contact force of a relay



DIMENSIONS

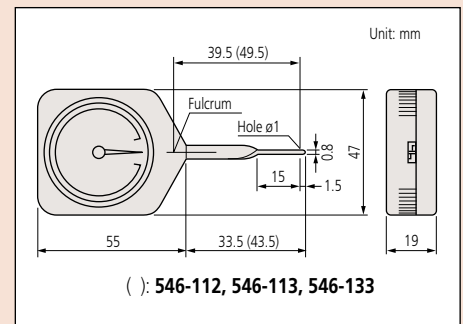

V-Block Set

SERIES 181

FEATURES

- Two V-blocks per set.
- Magnetic type is available. (The magnetic type V-block is not provided with a workpiece clamp.)

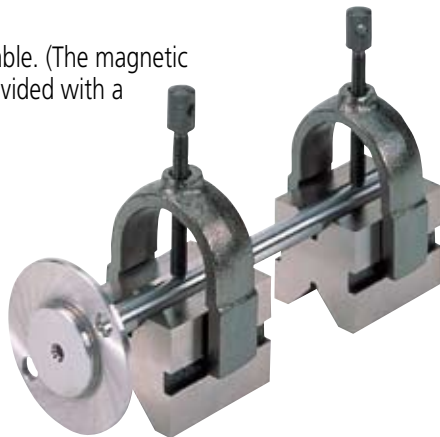

SPECIFICATIONS

Metric		
Max. workpiece dia.	Order No.	Remarks
25mm	181-902	With clamp

Inch		
Max. workpiece dia.	Order No.	Remarks
1"	181-901	With clamp

DIMENSIONS

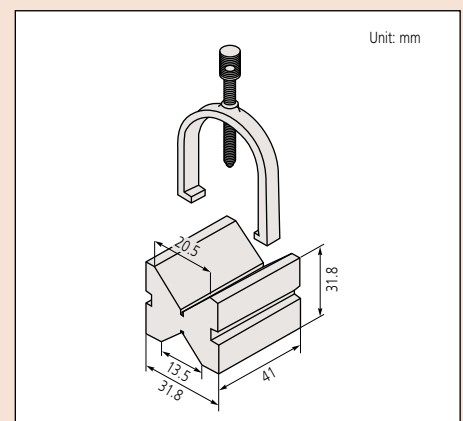

Magnetic Stands

SERIES 7

Mitutoyo's Magnetic Stands accept all dial indicators and dial test indicators. The ON-OFF switch offers instant mounting and dismounting without any adverse effect on the indicators or workpiece surface.

DIMENSIONS

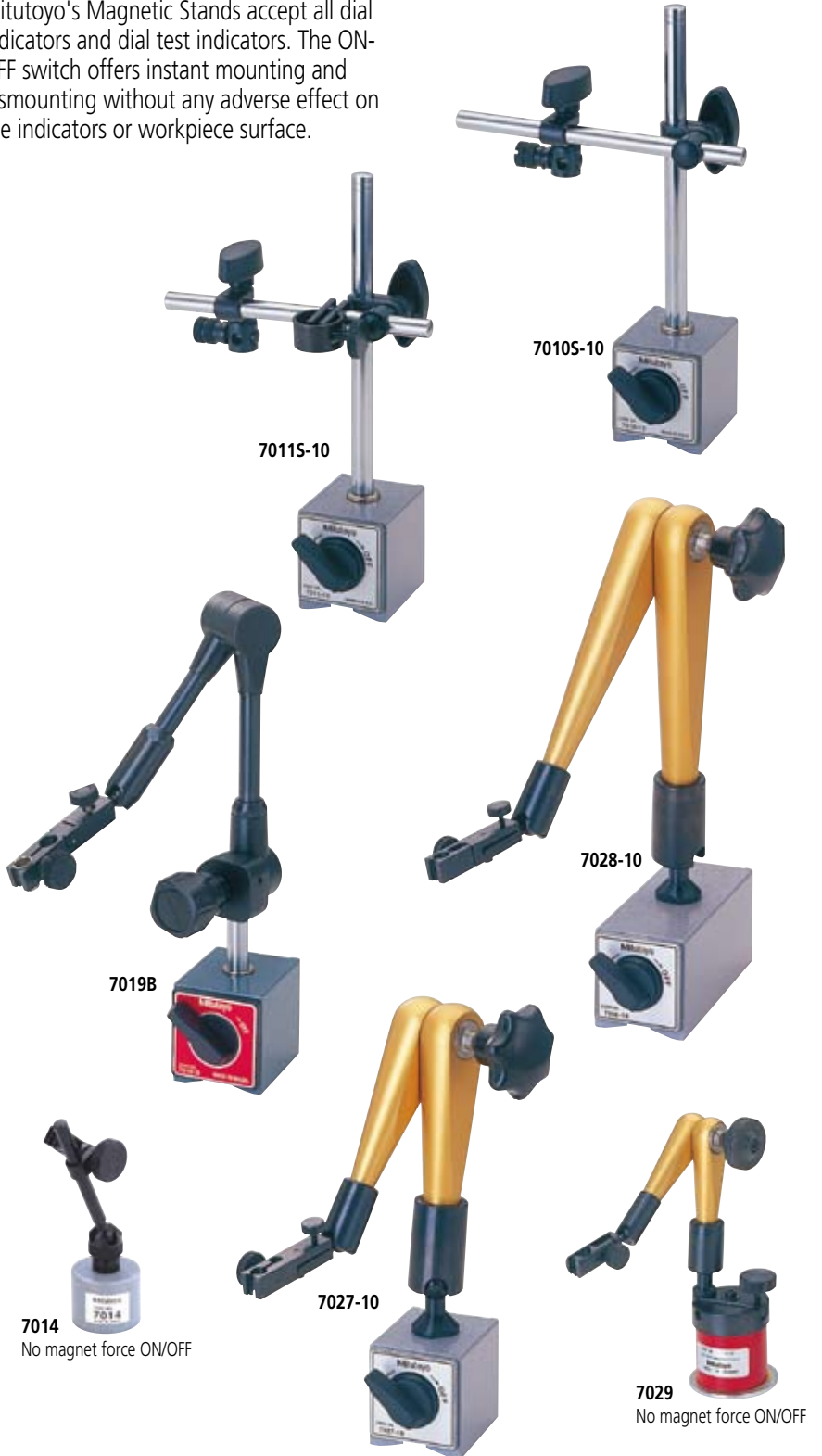
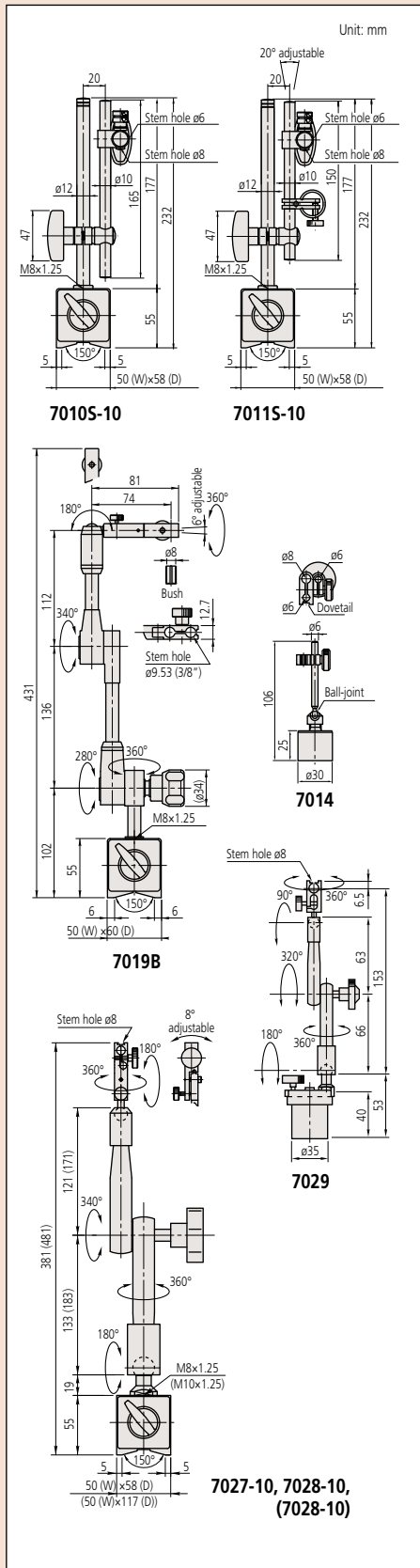

SPECIFICATIONS

Order No.	Description	Applicable holding stem dia.	Dovetail groove	Remarks
7010S-10	Magnetic stand	$\varnothing 6$ mm, $\varnothing 8$ mm	—	—
7011S-10	Magnetic stand	$\varnothing 6$ mm, $\varnothing 8$ mm	—	With fine adjustment
7014	Mini magnetic stand	$\varnothing 6$ mm, $\varnothing 8$ mm	Provided	Without magnet ON/OFF
7014E	Mini magnetic stand	$\varnothing 4$ mm, $\varnothing 9.5$ mm	Provided	Without magnet ON/OFF
7019B	Universal magnetic stand	$\varnothing 8$ mm, $\varnothing 9.53$ mm (3/8")	Provided	With hydraulic position lock
7027-10	Universal magnetic stand	$\varnothing 8$ mm	Provided	With hydraulic position lock
7028-10	Universal magnetic stand	$\varnothing 8$ mm	Provided	With hydraulic position lock
7029	Universal magnetic stand	$\varnothing 8$ mm	Provided	Without magnet ON/OFF

Dial Gage Stands

SERIES 7

Dial Gage Stands are designed for comparison measurements of size using a dial indicator or Digimatic Indicator.

FEATURES

- Vertical travel of the gage holder — Dial Gage Stand: 95mm (7007-10: 90mm), Transfer Stand: 320mm
- Fine-adjustment of 1mm is provided for zero-setting the indicator.
- With interchangeable anvil. Domed anvil (**101463**) is optional.



7001-10
with ø58mm serrated anvil



7002-10
with ø58mm flat anvil



7007-10
90mm square anvil

SPECIFICATIONS

Metric

Order No.	Stem hole	Remarks
7001-10	ø8mm, ø9.53mm	With serrated anvil
7002-10	ø8mm, ø9.53mm	With flat anvil
7007-10	ø8mm, ø9.53mm	With square anvil

DIMENSIONS

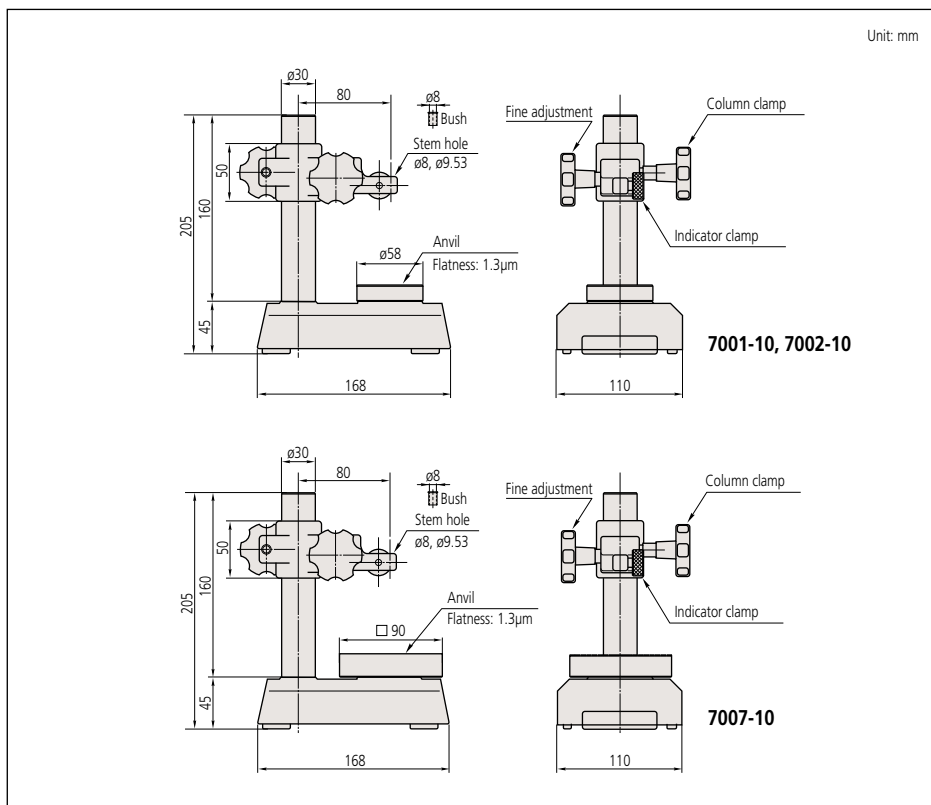

Optional Accessories

- 101461:** Hardened steel flat anvil
 - 101462:** Hardened steel serrated anvil
 - 101463:** Hardened steel domed anvil*
- *Not available for **7007-10**

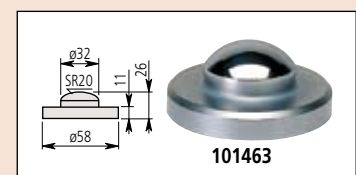
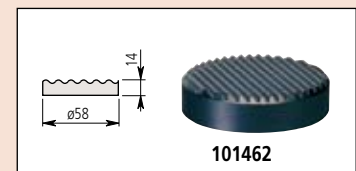
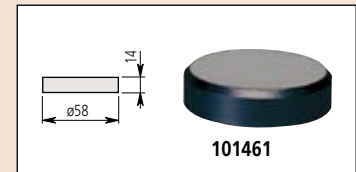

Transfer Stand

SERIES 519

Transfer Stands are designed for comparison measurements of size using a dial indicator or Digimatic Indicator.

FEATURES

- Vertical travel of the gage holder — Dial Gage Stand: 95mm, Transfer Stand: 320mm
- Fine-adjustment of 1mm is provided for zero-setting of the indicator.
- With interchangeable anvil. Domed anvil (**101463**) is optional.



519-109-10
with $\varnothing 58$ mm serrated anvil

Optional Accessories

101462: Hardened steel serrated anvil

101463: Hardened steel domed anvil

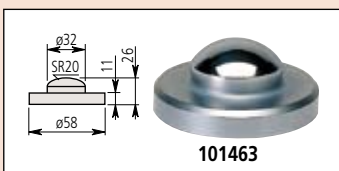
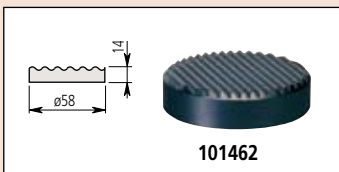

SPECIFICATIONS

Metric

Order No.	Stem hole	Remarks
519-109-10	$\varnothing 8$ mm, $\varnothing 9.53$ mm	With serrated anvil

DIMENSIONS

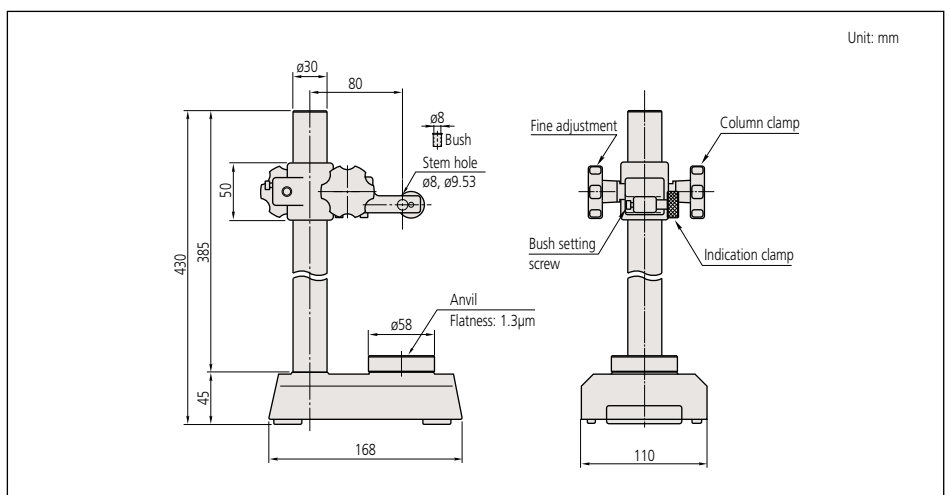

Granite Comparator Stands

SERIES 215

Mitutoyo's Granite Comparator Stands are basic building-blocks for the assembly of special-purpose, precision measuring equipment. By mounting precision measuring instruments such as Digimatic indicators, Mu-

Checker Cartridge Heads, and Linear Gages onto the stands, it is possible to handle all manner of measuring applications. The rigid granite base is free from burrs, pileups, rust, and deterioration over time.



215-153-10

SPECIFICATIONS

Order No.	Granite base size (W x D x H)	Column travel	Stem hole	Remarks
215-151-10	150 x 200 x 50mm	250mm	ø8mm, ø9.53mm	With fine adjustment of 1mm range
215-153-10	200 x 250 x 80mm	260mm	ø8mm, ø9.53mm	With fine adjustment of 1mm range
215-156-10	300 x 250 x 80mm	275mm	ø8mm, ø9.53mm, ø20mm	With fine adjustment over the entire travel

Optional Accessories

21JAA329: ø8mm bush
 21JAA330: ø9.53mm bush
 21JAA331: ø15mm bush
 only available for 215-156-10

DIMENSIONS

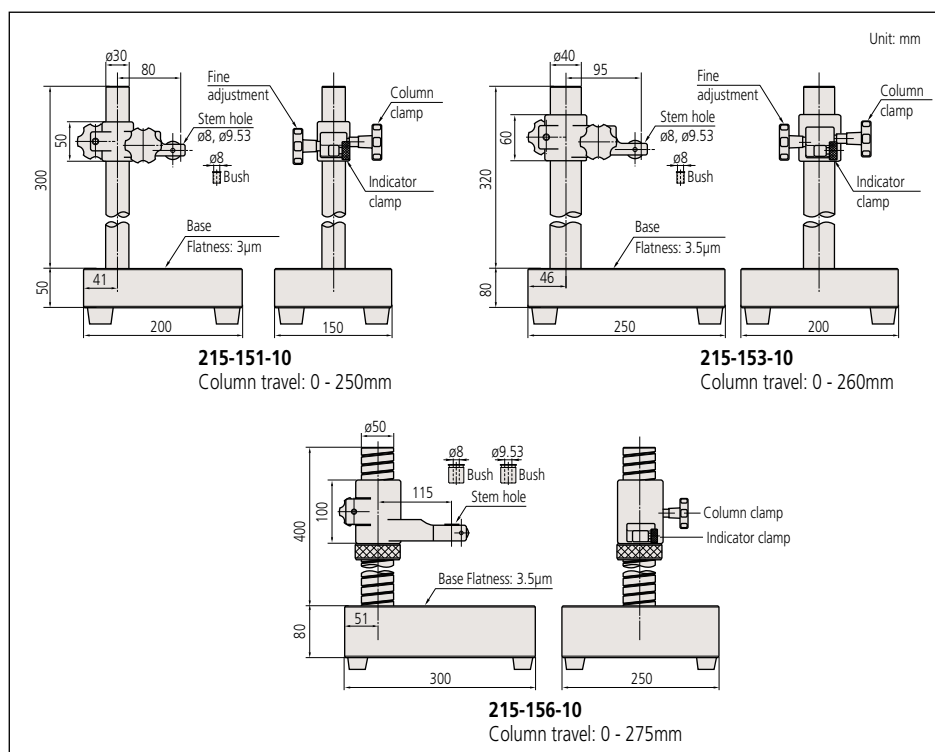

Comparator Stands

SERIES 215

Comparator Stands consists of a very stable, cast-iron base and an upright column with a mounting bracket that features fine adjustment. The grid type anvil prevents very flat workpieces from wringing to it.



215-405-10

Optional Accessories

- 21JAA329: $\varnothing 8$ mm bush*
- 21JAA330: $\varnothing 9.53$ mm (3/8") bush*
- 21JAA331: $\varnothing 15$ mm bush*

*Only available for 215-505-10.

SPECIFICATIONS

Order No.	Square anvil size (W x D)	Column travel	Stem hole	Remarks
215-405-10	110 x 110mm	235mm	$\varnothing 8$ mm, $\varnothing 9.53$ mm	With fine adjustment of 1mm range
215-505-10	150 x 150mm	275mm	$\varnothing 8$ mm, $\varnothing 9.53$ mm, $\varnothing 20$ mm	With fine adjustment over the entire travel

DIMENSIONS

