

B

Small Tool Instruments Micrometers Micrometers Heads



Micrometers



Micrometer Heads



MDC Micrometer

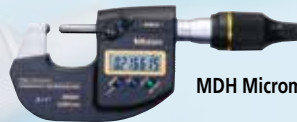

MDH Micrometer



QuantuMike



Digimatic Outside
Micrometer

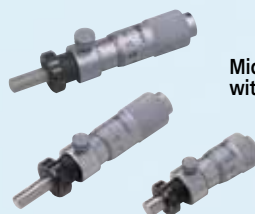

Micrometer Head
with spindle clamp

INDEX

Micrometers	
Coolant Proof Micrometer	B-2,3
Digimatic Micrometer	B-4
Digimatic Micrometer- MDC- Lite	B-4
MDH Micrometer	B-5
QuantuMike	B-6
ABSOLUTE Digimatic Micrometers	B-7
Quickmike	B-8
Outside Micrometers	B-9
Ratchet Thimble Micrometer	B-10
Outside Micrometers	B-11-19
Spline Micrometers	B-20
Point Micrometers	B-21
Crimp Height Micrometers	B-22
V-Anvil Micrometers	B-23,24
Limit Micrometers	B-25
Pana Micrometers	B-26
Spherical Face Micrometers	B-27
Tube Micrometers	B-28
Uni-Mike	B-29
Sheet Metal Micrometers	B-30
Blade Micrometers	B-31
Disk Micrometers	B-32
Paper Thickness Micrometers	B-33
Disk Micrometers	B-34,35
Gear Tooth Micrometers	B-36
Screw Thread Micrometers	B-37
Screw Thread Micrometers	B-38
3-Wire Thread Measuring System	B-39
Can Seam Micrometers	B-40
Hub Micrometers	B-41
Wire Micrometers	B-41
Digit Outside Micrometers	B-42
Indicating Micrometers	B-43
Snap Meters	B-43
Dial Snap Meters	B-44
Caliper Type Micrometers	B-45
Groove Micrometers	B-46
Small Hole Gage Set	B-47
Telescoping Gage Set	B-47
Micrometer Stands	B-48
Color Ratchet & Color Speeder	B-49
Spindle Attachment Tip	B-49
Micrometer Oil	B-49
Optical Parallels	B-50
Optical Flats	B-50
Micrometer Standards	B-51
Standards for Screw Thread Micrometers	B-52
Standards for V-Anvil Micrometers	B-52
Tool Kits	B-53,54
Micrometer Heads	
Micrometer Head Selection Guide	B-55
Digimatic Micrometer Heads	B-56
Digimatic Micrometer Heads	B-57
Micrometer Heads	B-58-71
Digital Micrometer Heads	B-72
Micrometer Heads	B-73
Micro Jack	B-73
Precision Lead Screw	B-74
Fixtures for Micrometer Heads	B-75,76

Coolant Proof Micrometer

SERIES 293 — with Dust/Water Protection Conforming to IP65 Level

FEATURES

- IP65 protection level, enabling use in environments exposed to cutting oil, etc*.
*Anti-corrosion treatment is required after use.
- Measurement data output function is available with a water-resistant connection cable.
- Auto power ON/OFF function.
- A nonslip surface with raised dots is employed for the frame cover and surface panel to achieve stable handheld measurement.
- Certificate of inspection* is included. (2" /50mm or less range models)
*It is not the type used to obtain calibration certificates.
- With a standard bar except for 0-1"/0-25mm model.
- Supplied in fitted case. Plastic case up to 6"/150mm, wooden box over 6"/150mm



293-330-30



293-352-10



Oil-resistance materials are used in all plastic components.



Measurement data output function is available with a water-resistant connection cable.



Employed nonslip surface with raised dots

Mitutoyo		CERTIFICATE OF INSPECTION / 検査成績書	
1. Item (品名)	Electronic Micrometer	Measuring range	0-25mm
Model No.	293-330	Model No.	293-330
Code No.	293-330	Serial No.	293-330
2. Model and Specification	Resolution: 0.0005mm	Standard temperature	20°C
3. Measurement Date	2013.08.17	Inspected by	Y. S. Lee
4. Measuring Faces	Carbide tipped	Measuring Faces	Carbide tipped
5. Accuracy	Refer to the list of specifications	Resolution	0.0005mm
6. Flatness	0.00012mm	Parallelism	0.0004mm
7. Parallelism	0.0004mm	Surface Roughness	0.1µm
8. Measuring Faces	Carbide tipped	Measuring Faces	Carbide tipped
9. Accuracy	Refer to the list of specifications	Resolution	0.0005mm
10. Flatness	0.00012mm	Parallelism	0.0004mm
11. Surface Roughness	0.1µm	Measuring Faces	Carbide tipped
12. Measuring Faces	Carbide tipped	Measuring Faces	Carbide tipped
13. Accuracy	Refer to the list of specifications	Resolution	0.0005mm
14. Flatness	0.00012mm	Parallelism	0.0004mm
15. Surface Roughness	0.1µm	Measuring Faces	Carbide tipped
16. Measuring Faces	Carbide tipped	Measuring Faces	Carbide tipped
17. Accuracy	Refer to the list of specifications	Resolution	0.0005mm
18. Flatness	0.00012mm	Parallelism	0.0004mm
19. Surface Roughness	0.1µm	Measuring Faces	Carbide tipped
20. Measuring Faces	Carbide tipped	Measuring Faces	Carbide tipped
21. Accuracy	Refer to the list of specifications	Resolution	0.0005mm
22. Flatness	0.00012mm	Parallelism	0.0004mm
23. Surface Roughness	0.1µm	Measuring Faces	Carbide tipped
24. Measuring Faces	Carbide tipped	Measuring Faces	Carbide tipped
25. Accuracy	Refer to the list of specifications	Resolution	0.0005mm
26. Flatness	0.00012mm	Parallelism	0.0004mm
27. Surface Roughness	0.1µm	Measuring Faces	Carbide tipped
28. Measuring Faces	Carbide tipped	Measuring Faces	Carbide tipped
29. Accuracy	Refer to the list of specifications	Resolution	0.0005mm
30. Flatness	0.00012mm	Parallelism	0.0004mm
31. Surface Roughness	0.1µm	Measuring Faces	Carbide tipped
32. Measuring Faces	Carbide tipped	Measuring Faces	Carbide tipped
33. Accuracy	Refer to the list of specifications	Resolution	0.0005mm
34. Flatness	0.00012mm	Parallelism	0.0004mm
35. Surface Roughness	0.1µm	Measuring Faces	Carbide tipped
36. Measuring Faces	Carbide tipped	Measuring Faces	Carbide tipped
37. Accuracy	Refer to the list of specifications	Resolution	0.0005mm
38. Flatness	0.00012mm	Parallelism	0.0004mm
39. Surface Roughness	0.1µm	Measuring Faces	Carbide tipped
40. Measuring Faces	Carbide tipped	Measuring Faces	Carbide tipped
41. Accuracy	Refer to the list of specifications	Resolution	0.0005mm
42. Flatness	0.00012mm	Parallelism	0.0004mm
43. Surface Roughness	0.1µm	Measuring Faces	Carbide tipped
44. Measuring Faces	Carbide tipped	Measuring Faces	Carbide tipped
45. Accuracy	Refer to the list of specifications	Resolution	0.0005mm
46. Flatness	0.00012mm	Parallelism	0.0004mm
47. Surface Roughness	0.1µm	Measuring Faces	Carbide tipped
48. Measuring Faces	Carbide tipped	Measuring Faces	Carbide tipped
49. Accuracy	Refer to the list of specifications	Resolution	0.0005mm
50. Flatness	0.00012mm	Parallelism	0.0004mm
51. Surface Roughness	0.1µm	Measuring Faces	Carbide tipped
52. Measuring Faces	Carbide tipped	Measuring Faces	Carbide tipped
53. Accuracy	Refer to the list of specifications	Resolution	0.0005mm
54. Flatness	0.00012mm	Parallelism	0.0004mm
55. Surface Roughness	0.1µm	Measuring Faces	Carbide tipped
56. Measuring Faces	Carbide tipped	Measuring Faces	Carbide tipped
57. Accuracy	Refer to the list of specifications	Resolution	0.0005mm
58. Flatness	0.00012mm	Parallelism	0.0004mm
59. Surface Roughness	0.1µm	Measuring Faces	Carbide tipped
60. Measuring Faces	Carbide tipped	Measuring Faces	Carbide tipped
61. Accuracy	Refer to the list of specifications	Resolution	0.0005mm
62. Flatness	0.00012mm	Parallelism	0.0004mm
63. Surface Roughness	0.1µm	Measuring Faces	Carbide tipped
64. Measuring Faces	Carbide tipped	Measuring Faces	Carbide tipped
65. Accuracy	Refer to the list of specifications	Resolution	0.0005mm
66. Flatness	0.00012mm	Parallelism	0.0004mm
67. Surface Roughness	0.1µm	Measuring Faces	Carbide tipped
68. Measuring Faces	Carbide tipped	Measuring Faces	Carbide tipped
69. Accuracy	Refer to the list of specifications	Resolution	0.0005mm
70. Flatness	0.00012mm	Parallelism	0.0004mm
71. Surface Roughness	0.1µm	Measuring Faces	Carbide tipped
72. Measuring Faces	Carbide tipped	Measuring Faces	Carbide tipped
73. Accuracy	Refer to the list of specifications	Resolution	0.0005mm
74. Flatness	0.00012mm	Parallelism	0.0004mm
75. Surface Roughness	0.1µm	Measuring Faces	Carbide tipped
76. Measuring Faces	Carbide tipped	Measuring Faces	Carbide tipped
77. Accuracy	Refer to the list of specifications	Resolution	0.0005mm
78. Flatness	0.00012mm	Parallelism	0.0004mm
79. Surface Roughness	0.1µm	Measuring Faces	Carbide tipped
80. Measuring Faces	Carbide tipped	Measuring Faces	Carbide tipped
81. Accuracy	Refer to the list of specifications	Resolution	0.0005mm
82. Flatness	0.00012mm	Parallelism	0.0004mm
83. Surface Roughness	0.1µm	Measuring Faces	Carbide tipped
84. Measuring Faces	Carbide tipped	Measuring Faces	Carbide tipped
85. Accuracy	Refer to the list of specifications	Resolution	0.0005mm
86. Flatness	0.00012mm	Parallelism	0.0004mm
87. Surface Roughness	0.1µm	Measuring Faces	Carbide tipped
88. Measuring Faces	Carbide tipped	Measuring Faces	Carbide tipped
89. Accuracy	Refer to the list of specifications	Resolution	0.0005mm
90. Flatness	0.00012mm	Parallelism	0.0004mm
91. Surface Roughness	0.1µm	Measuring Faces	Carbide tipped
92. Measuring Faces	Carbide tipped	Measuring Faces	Carbide tipped
93. Accuracy	Refer to the list of specifications	Resolution	0.0005mm
94. Flatness	0.00012mm	Parallelism	0.0004mm
95. Surface Roughness	0.1µm	Measuring Faces	Carbide tipped
96. Measuring Faces	Carbide tipped	Measuring Faces	Carbide tipped
97. Accuracy	Refer to the list of specifications	Resolution	0.0005mm
98. Flatness	0.00012mm	Parallelism	0.0004mm
99. Surface Roughness	0.1µm	Measuring Faces	Carbide tipped
100. Measuring Faces	Carbide tipped	Measuring Faces	Carbide tipped

Certificate of inspection

Technical Data

- Accuracy: Refer to the list of specifications.
- Resolution: .00005"/0.001mm or 0.001mm (up to 4" models)
.0001" / 0.001mm (over 4" models)
- Flatness: .000012"/0.3µm
- Parallelism: .00004"/1µm for models up to 2"/50mm
.00008"/2µm for models up to 4"/100mm
.00012"/3µm for models up to 7"/175mm
.00016"/4µm for models up to 11"/275mm
.0002"/5µm for models over 12"/300mm
- Measuring faces: Carbide tipped
- Display: LCD
- Battery: SR44 (1 pc.), **938882**
- Battery life: Approx. 2.4 years under normal use
(8 months: over 4"/100mm models)
- Dust/Water protection level: IP65

Function

- Origin-set, Zero / ABS, Hold, Auto power on/off,
- Data output (output models),
- inch/mm conversion (on inch/metric models only)
- Alarm: Low voltage, Counting value composition error

Optional Accessories

- 05CZA662:** SPC cable with data switch (40"/1m)
- 05CZA663:** SPC cable with data switch (80"/2m)
- USB Input Tool Direct**
- USB-ITN-B (2m): 06ADV380B**



SPC cable with data switch

Connecting cable for **U-Wave-T (160mm)**
02AZD790B
Refer to page A-13.

SPECIFICATIONS

Metric With ratchet stop

Range	Resolution	Order No.	Accuracy
0 - 25mm	0.001mm	293-230-30 / 293-240-30*	±1µm
25 - 50mm	0.001mm	293-231-30 / 293-241-30*	±1µm
50 - 75mm	0.001mm	293-232-30 / 293-242-30*	±1µm
75 - 100mm	0.001mm	293-233-30 / 293-243-30*	±2µm
100 - 125mm	0.001mm	293-250-10	±2µm
125 - 150mm	0.001mm	293-251-10	±2µm
150 - 175mm	0.001mm	293-252-10	±3µm
175 - 200mm	0.001mm	293-253-10	±3µm
200 - 225mm	0.001mm	293-254-10	±3µm
225 - 250mm	0.001mm	293-255-10	±4µm
250 - 275mm	0.001mm	293-256-10	±4µm
275 - 300mm	0.001mm	293-257-10	±4µm

*without SPC data output

Metric With ratchet thimble

Range	Resolution	Order No.	Accuracy
0 - 25mm	0.001mm	293-234-30 / 293-244-30*	±1µm
25 - 50mm	0.001mm	293-235-30 / 293-245-30*	±1µm
50 - 75mm	0.001mm	293-236-30 / 293-246-30*	±1µm
75 - 100mm	0.001mm	293-237-30 / 293-247-30*	±2µm

*without SPC data output

Metric Micrometer Set

Range	Order No.	Included in set
0-50mm (2pcs. Set)	293-966-30	293-230-30, 293-231-30, 25mm CERA block, plastic case
0-75mm (3pcs. Set)	293-962-30	293-230-30, 293-231-30, 293-232-30, 2 standard bars, plastic case
0-100mm (4pcs. Set)	293-963-30	293-230-30, 293-231-30, 293-232-30, 293-233-30, 3 standard bars, wooden box

Inch/Metric With ratchet stop

Range	Resolution	Order No.	Accuracy
0 - 1" / 0 - 25.4mm	.00005"/0.001mm	293-330-30 / 293-340-30*	±.00005"
1" - 2" / 25.4 - 50.8mm	.00005"/0.001mm	293-331-30 / 293-341-30*	±.00005"
2" - 3" / 50.8 - 76.2mm	.00005"/0.001mm	293-332-30 / 293-342-30*	±.00005"
3" - 4" / 76.2 - 101.6mm	.00005"/0.001mm	293-333-30 / 293-343-30*	±.0001"
4" - 5" / 101.6 - 127.0mm	.0001"/0.001mm	293-350-10	±.0001"
5" - 6" / 127.0 - 152.4mm	.0001"/0.001mm	293-351-10	±.0001"
6" - 7" / 152.4 - 177.8mm	.0001"/0.001mm	293-352-10	±.00015"
7" - 8" / 177.8 - 203.2mm	.0001"/0.001mm	293-353-10	±.00015"
8" - 9" / 203.2 - 228.6mm	.0001"/0.001mm	293-354-10	±.00015"
9" - 10" / 228.6 - 254.0mm	.0001"/0.001mm	293-355-10	±.0002"
10" - 11" / 254.0 - 279.4mm	.0001"/0.001mm	293-356-10	±.0002"
11" - 12" / 279.4 - 304.8mm	.0001"/0.001mm	293-357-10	±.0002"

*without SPC data output

Inch/Metric With ratchet thimble

Range	Resolution	Order No.	Accuracy
0 - 1" / 0 - 25.4mm	.00005" / 0.001mm	293-334-30 / 293-344-30*	±.00005"
0 - 1" / 0 - 25.4mm	.0001" / 0.001mm	293-349-30*	±.0001"
1" - 2" / 25.4 - 50.8mm	.00005" / 0.001mm	293-345-30*	±.00005"
2" - 3" / 50.8 - 76.2mm	.00005" / 0.001mm	293-346-30*	±.00005"
3" - 4" / 76.2 - 101.6mm	.00005" / 0.001mm	293-347-30*	±.0001"

*without SPC data output

Inch/Metric With friction thimble

Range	Resolution	Order No.	Accuracy
0 - 1" / 0 - 25.4mm	.00005" / 0.001mm	293-335-30 / 293-348-30*	±.00005"
1" - 2" / 25.4 - 50.8mm	.00005" / 0.001mm	293-336-30	±.00005"

*without SPC data output

Inch/Metric Micrometer Set .00005" / 0.001mm graduation model

Range	Order No.	Included in set
0 - 3" / 0 - 76.2mm (3 pcs. set)	293-960-30	293-330-30, 293-331-30, 293-332-30, 2 standard bars, plastic case
0 - 4" / 0 - 101.6mm (4 pcs. set)	293-961-30	293-330-30, 293-331-30, 293-332-30, 293-333-30, 3 standard bars, wooden box

DIMENSIONS AND MASS

Ratchet stop type (up to 100mm/4")

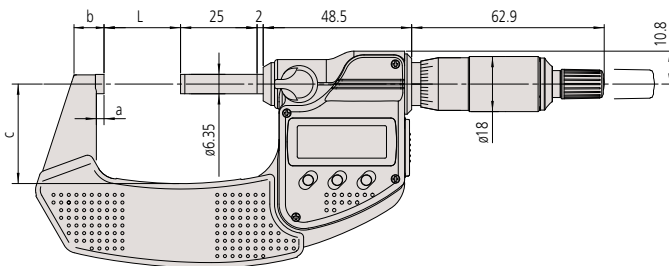

Ratchet thimble type and friction thimble type

Unit: mm

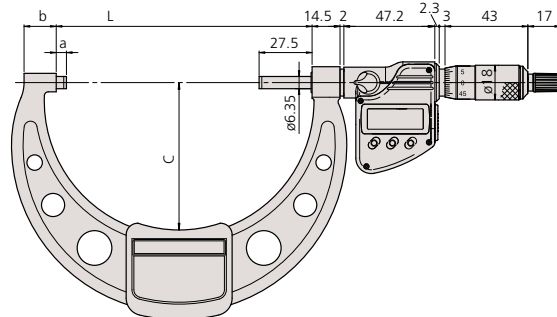
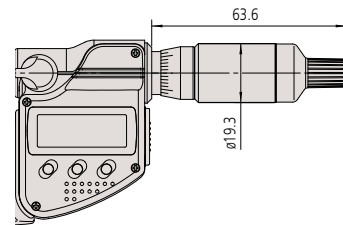

Ratchet stop type (over 100mm/4" to 300mm/12")

Range (Metric / Inch)	L	a	b	c	Mass (g)
0 - 25mm / 0-1"	0	2.5	9	(25)	270
25 - 50mm / 1-2"	25	2.5	9.8	(32.5)	330
50 - 75mm / 2-3"	50	2.5	12.6	(47)	470
75 - 100mm / 3-4"	75	2.5	14	(60)	625
100 - 125mm / 4-5"	132.8	5.3	16.7	(76.5)	600
125 - 150mm / 5-6"	158.2	5.7	18.8	(91)	740
150 - 175mm / 6-7"	183.6	6.1	19.1	(103.1)	800
175 - 200mm / 7-8"	208.8	6.3	18.2	(115.3)	970
200 - 225mm / 8-9"	234.2	6.7	16.8	(126.8)	1100
225 - 250mm / 9-10"	258	5.5	18	(139.8)	1270
250 - 275mm / 10-11"	284	18	28	(152.3)	1340
275 - 300mm / 11-12"	309	18	28	(166)	1540

Digimatic Micrometer

SERIES 293



293-582

SPECIFICATIONS

Metric With ratchet stop

Range	Resolution	Order No.	Accuracy
300 - 325mm	0.001mm	293-582	±6µm
325 - 350mm	0.001mm	293-583	±6µm
350 - 375mm	0.001mm	293-584	±6µm
375 - 400mm	0.001mm	293-585	±7µm
400 - 425mm	0.001mm	293-586	±7µm
425 - 450mm	0.001mm	293-587	±7µm
450 - 475mm	0.001mm	293-588	±8µm
475 - 500mm	0.001mm	293-589	±8µm

DIMENSIONS

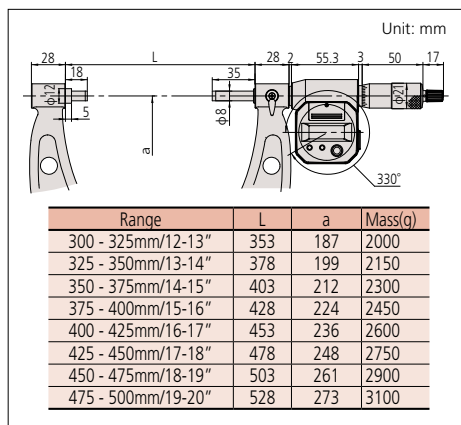

Technical Data

Accuracy: Refer to the list of specifications.
 Resolution: .0001" / 0.001mm or 0.001mm
 Flatness: .000024" / 0.6µm
 Parallelism: .0002" / 5µm for models up to 15" / 375mm
 .00024" / 6µm for models up to 19" / 475mm
 .00028" / 7µm for models over 20" / 500mm
 Measuring faces: Carbide tipped
 Display: LCD
 Battery: SR44 (2 pcs.), **938882**
 Battery life: Approx. 1.8 years under normal use

Function

Preset, Zero-setting, Power ON/OFF, Data hold, Data output, inch/mm conversion (on inch/metric models only)
 Alarm: Low voltage, Counting value composition error

Optional Accessories

959149: SPC cable (40"/1m) Straight type
959150: SPC cable (80"/2m) Straight type
04AZB512: SPC cable L-type (40"/1m)
04AZB513: SPC cable L-type (80"/2m)



Digimatic Micrometer

SERIES 293 MDC-Lite

FEATURES

- Provided only with a zero set and in/mm (inch/metric models only) keys.
- A ratchet stop or friction thimble for a constant measuring force.
- Measurement readout with large characters on the LCD screen.
- No spindle clamp. No data output
- Supplied in fitted plastic case



293-831-30

Inch/Metric With ratchet stop

Range	Resolution	Order No.	Accuracy
0 - 1" / 0 - 25.4mm	.00005" / 0.001mm	293-831-30	±.0001"

Inch/Metric With friction thimble

Range	Resolution	Order No.	Accuracy
0 - 1" / 0 - 25.4mm	.00005" / 0.001mm	293-832-30	±.0001"

SPECIFICATIONS

Metric With ratchet stop

Range	Resolution	Order No.	Accuracy
0 - 25mm	0.001mm	293-821-30	±2µm

DIMENSIONS AND MASS

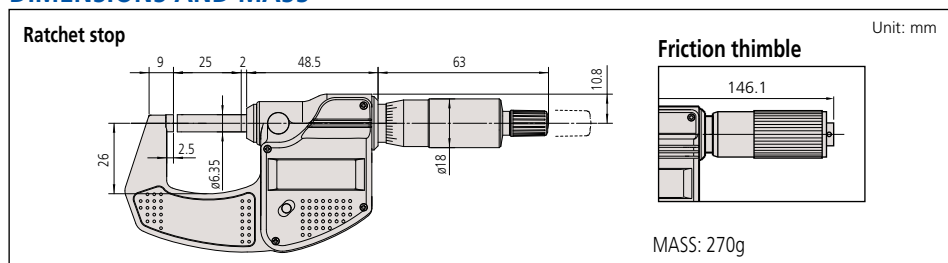

Technical Data

Accuracy: Refer to the list of specifications.
 Resolution: .00005" / 0.001mm or 0.001mm
 Flatness: .000012" / 0.3µm
 Parallelism: .00008" / 2µm
 Measuring faces: Carbide tipped
 Display: LCD
 Battery: SR44 (1 pc.), **938882**
 Battery life: Approx. 2.4 years under normal use

Function

Origin-set, Automatic power on/off, inch/mm conversion (on inch/metric models only)
 Alarm: Low voltage, Counting value composition error



MDH Micrometer

SERIES 293 — High-Accuracy Sub-Micron Digimatic Micrometer

Technical Data

Flatness: 0.3µm/.000012"
 Parallelism: 0.6µm/.000024
 Measuring force: 7 to 9N
 Power supply: Lithium battery **05SAA217** (CR2032) x 1
 Battery life: Approx. two years when used under normal conditions

Functions

Preset (ABS measurement system)
 Zero-setting (INC measurement system)
 Hold, Resolution switching, Function lock, On/off, Auto power off, Measurement data output, Error alarm

Optional Accessories

05CZA662: SPC cable with data switch (1m/40")
05CZA663: SPC cable with data switch (2m/80")

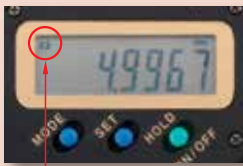

Function lock

Heat shield



FEATURES

- Enabling .000005"/0.1µm resolution measurement, this micrometer is ideal for customers who need to make highly accurate measurements with a hand-held tool.
- A highly rigid frame and high-performance constant-force mechanism* enable more stable measurement, while the clicks emitted while the workpiece is being measured assure the operator that measurement is proceeding normally.
- Body heat transferred to the instrument is reduced by a (removable) heat shield, minimizing the error caused by thermal expansion of the frame when performing handheld measurements.
- The ABS (absolute) rotary sensor also eliminates the need to perform origin setting each time the power is turned on, letting you start measuring straight away. With no possibility of overspeed errors, the High-Accuracy Digimatic Micrometer also delivers a higher level of reliability.

* Patent pending in Japan, the United States of America, the European Union, and China.



SPECIFICATIONS

Metric					
Order No.	Range	Resolution	Accuracy	Measuring surface	Mass
293-100	0 - 25mm	0.0001mm/0.0005mm (switchable)	±0.5µm	ø3.2mm	400g (440g w/Heat shield)

Inch/Metric					
Order No.	Range	Resolution	Accuracy	Measuring surface	Mass
293-130	0 - 1" 0 - 25.4mm	.000005"/0.00002" 0.0001mm/0.0005mm (switchable)	±.00002"	ø3.2mm	400g (440g w/Heat shield)

DIMENSIONS

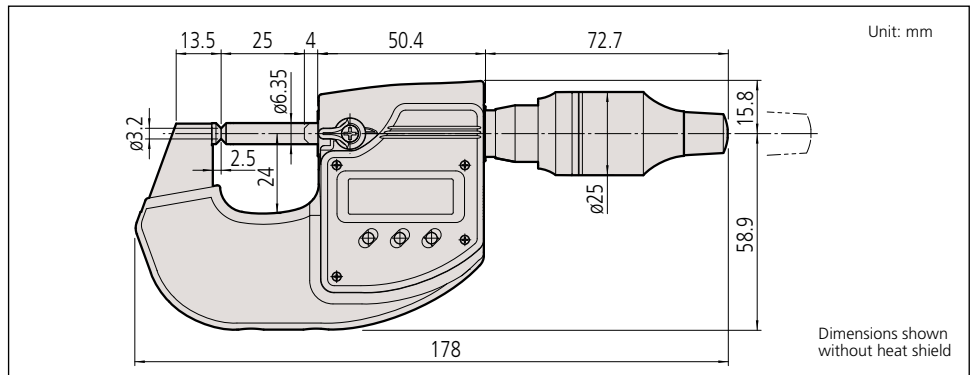

QuantuMike

SERIES 293 — Coolant Proof Micrometer

FEATURES

- Faster measurement with 2mm per revolution instead of the standard 0.5mm.
- A patented ratchet thimble mechanism helps ensure repeatability.
- A function lock helps prevent error.
- IP-65 protection level.
- Certificate of inspection provided.
- With a standard bar except for 0-25mm/0-1" model.
- Supplied in fitted plastic case.



293-180



293-142



SPECIFICATIONS

Metric

Range	Resolution	Order No.	Accuracy
0-25mm	0.001mm	293-140	1µm
0-25mm	0.001mm	293-145*	1µm
25-50mm	0.001mm	293-141	1µm
25-50mm	0.001mm	293-146*	1µm
50-75mm	0.001mm	293-142	2µm
50-75mm	0.001mm	293-147*	2µm
75-100mm	0.001mm	293-143	2µm
75-100mm	0.001mm	293-148*	2µm

* without SPC data output

Inch/Metric

Range	Resolution	Order No.	Accuracy
0-1"/0 - 25.4mm	.00005"/0.001mm	293-180	.00005"
0-1"/0 - 25.4mm	.00005"/0.001mm	293-185*	.00005"
1-2"/25.4 - 50.8mm	.00005"/0.001mm	293-181	.00005"
1-2"/25.4 - 50.8mm	.00005"/0.001mm	293-186*	.00005"
2-3"/50.8 - 76.2mm	.00005"/0.001mm	293-182	.0001"
2-3"/50.8 - 76.2mm	.00005"/0.001mm	293-187*	.0001"
3-4"/76.2 - 101.6mm	.00005"/0.001mm	293-183	.0001"
3-4"/76.2 - 101.6mm	.00005"/0.001mm	293-188*	.0001"

* without SPC data output

DIMENSIONS AND MASS

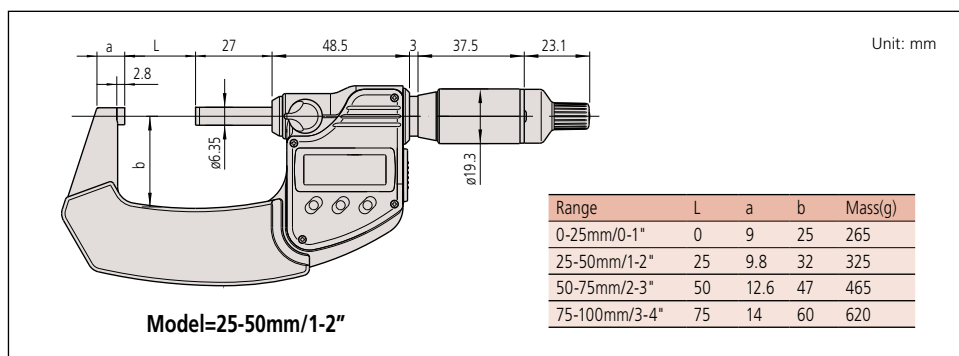

Certificate of inspection

Technical Data

Accuracy: Refer to the list of specifications.
 Resolution: 0.001mm or .00005"/0.001mm
 Flatness: 0.3µm/.000012"
 Parallelism: 1µm/.00004" for models up to 50mm/2"
 2µm/.00008" for models up to 100mm/4"
 Measuring force: 7-12N
 Measuring faces: Carbide tipped
 Display: LCD
 Battery: SR44 (1 pc.), **938882**
 Battery life: Approx. 1.2 years under normal use
 (8 months: over 100mm models)
 Dust/Water protection level: IP65

Function

Origin-set, Zero / ABS, Hold, Function locks, Auto power on/off,
 Data output (output models),
 inch/mm conversion (on inch/metric models only)
 Alarm: Low voltage, Counting value composition error

Optional Accessories

- 05CZA662:** SPC cable with data switch (1m/40")
- 05CZA663:** SPC cable with data switch (2m/80")
- USB Input Tool Direct**
- USB-ITN-B (2m): 06ADV380B**
- Connecting cable for **U-Wave-T (160mm)**
- 02AZD790B**



516-529-26 Inspection Gage Block Set
 Rectangular Steel Gage Block
 10 pc. blocks and 1 pc. optical parallel

516-319-26 Inspection Gage Block Set
 Rectangular Cera Gage Block
 10 pc. blocks and 1 pc. optical parallel

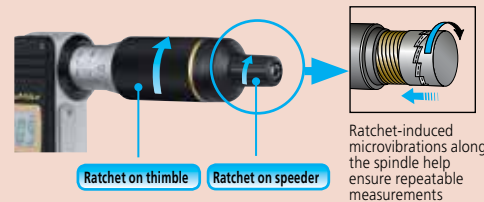

Significant reduction in positioning time

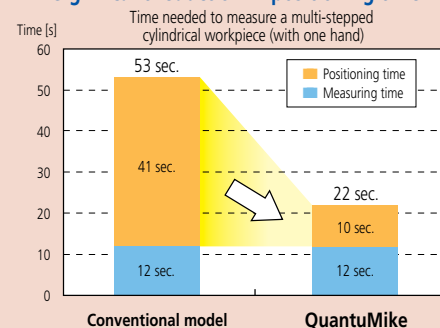



ABSOLUTE Digimatic Micrometers

SERIES 227 — with Adjustable Measuring Force

Technical Data

Accuracy: Refer to the list of specifications.
 Resolution: .00005" / 0.001mm or 0.001mm
 Flatness: .000012" / 0.3µm
 Parallelism: .00008" / 2µm
 Accuracy of selected measuring force:
 ± (0.1+selected measuring force/10)N
 for 0.5-2.5N models
 ± (0.4+selected measuring force/10)N
 for 2-10N models

Measuring faces: Carbide tipped
 Display: LCD
 Battery: SR44 (1 pc.), **938882**
 Battery life: Approx. 3 years under normal use
 (1 year for .6 - 1.2" / 15-30mm, .4 - .8" /
 10-20mm, .8-1.2" / 20-30mm range model)

Function

Origin, Hold / Data, ON/OFF, Zero / ABS,
 inch/mm conversion (on inch/metric models only)
 Alarm: Low voltage, Counting value composition error

Optional Accessories

937387: SPC cable (40" / 1m)
965013: SPC cable (80" / 2m)



FEATURES

- Constant and low measuring force mechanism in the thimble.
- Adjustable measuring force* accommodates various kind of work materials.
 *0.5-2.5N or 2-10N
- The measurement-value hold function automatically retains the data at a specified measuring force, ensuring accuracy.
- Non-rotating spindle and the new ratchet friction thimble.
- Speedy spindle feed by .4"/rev and 10mm/rev for inch/metric model.
- With absolute linear scale.
- With SPC data output.
- With a standard bar to set the origin point (except for 0-15mm, 0-10mm, 0-.6", and 0-.4" models).
- Supplied in fitted plastic case.



227-201

SPECIFICATIONS

Metric					
Order No.	Range	Resolution	Accuracy	Measuring Force	Mass(g)
227-201	0-15mm	0.001mm	±2µm	0.5-2.5 (0.5, 1.0, 1.5, 2, 2.5) N	300
227-203	15-30mm	0.001mm	±2µm	0.5-2.5 (0.5, 1.0, 1.5, 2, 2.5) N	380
227-205	0-10mm	0.001mm	±2µm	2-10 (2, 4, 6, 8, 10) N	340
227-206	10-20mm	0.001mm	±2µm	2-10 (2, 4, 6, 8, 10) N	425
227-207	20-30mm	0.001mm	±2µm	2-10 (2, 4, 6, 8, 10) N	415

Inch/Metric					
Order No.	Range	Resolution	Accuracy	Measuring Force	Mass(g)
227-211	0-.6"	.00005"/0.001mm	±.0001"	0.5-2.5 (0.5, 1.0, 1.5, 2, 2.5) N	300
227-213	.6-1.2"	.00005"/0.001mm	±.0001"	0.5-2.5 (0.5, 1.0, 1.5, 2, 2.5) N	380
227-215	0-.4"	.00005"/0.001mm	±.0001"	2-10 (2, 4, 6, 8, 10) N	340
227-216	.4-.8"	.00005"/0.001mm	±.0001"	2-10 (2, 4, 6, 8, 10) N	425
227-217	.8-1.2"	.00005"/0.001mm	±.0001"	2-10 (2, 4, 6, 8, 10) N	415

DIMENSIONS AND MASS

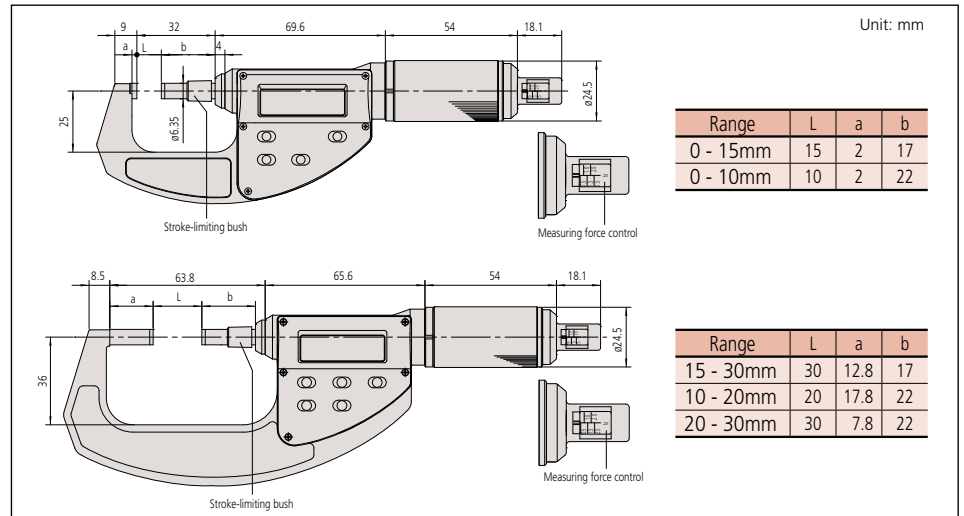

Quickmike

SERIES 293 — IP-54 ABSOLUTE Digimatic Micrometers

The Quickmike provides a speedy spindle feed of 10mm / .4" per thimble rotation as compared to the conventional micrometer with 0.5mm / .025" per rotation. Its wide 30mm / 1.2" measuring range allows various workpieces with different shapes to be measured quickly.

FEATURES

- Non-rotating spindle and the new ratchet friction thimble.
- Speedy spindle feed by 10mm/rev and .4"/rev for inch/metric models.
- With absolute linear scale.
- IP54 dust/water protection (when not connected with data output cable).
- With SPC data output.
- With a standard bar to set the origin point (for models with a range over 30mm / 1.2").
- Supplied in fitted plastic case.



293-676



293-677



293-678



293-679

SPECIFICATIONS

Metric			
Range	Resolution	Order No.	Accuracy
0 - 30mm	0.001mm	293-666	±2µm
25 - 55mm	0.001mm	293-667	±2µm
50 - 80mm	0.001mm	293-668	±3µm
75 - 105mm	0.001mm	293-669	±3µm

Inch/Metric			
Range	Resolution	Order No.	Accuracy
0 - 1.2" / 0 - 30.48mm	.00005" / 0.001mm	293-676	±.0001"
1" - 2.2" / 25.4 - 55.88mm	.00005" / 0.001mm	293-677	±.0001"
2" - 3.2" / 50.8 - 81.28mm	.00005" / 0.001mm	293-678	±.00015"
3" - 4.2" / 76.2 - 106.68mm	.00005" / 0.001mm	293-679	±.00015"

DIMENSIONS AND MASS

Range	L	a	b	c	Mass
0 - 30mm / 0 - 1.2"	34.8	2.8	6.2	25	275
25 - 55mm / 1 - 2.2"	59.8	2.8	8.5	36	355
50 - 80mm / 2 - 3.2"	84.8	2.8	10.3	47	525
75 - 105mm / 3 - 4.2"	109.8	2.8	10.7	60	625

Unit: mm



Technical Data

Accuracy: Refer to the list of specifications.
 Resolution: 0.001mm or .00005"/0.001mm
 Flatness: 0.3µm / .000012"
 Parallelism: 2µm / .00008" for models up to 80mm / 3.2"
 3µm / .00012" for models up to 105mm / 4.2"
 Measuring force: 5-10N
 Measuring faces: Carbide tipped
 Display: LCD
 Battery: SR44 (1 pc.), **938882**
 Battery life: Approx. 3 years under normal use
 (1 year for models over 30mm / 1.2")
 Dust/Water protection level: IP54

Function

Origin, Hold / Data, ON/OFF, Zero / ABS,
 inch/mm conversion (on inch/metric models only)
 Alarm: Low voltage, Counting value composition error

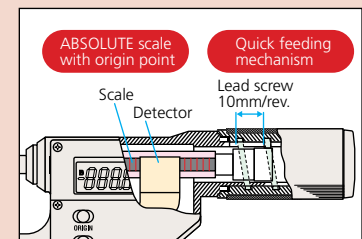

Optional Accessories

937387: SPC cable (1m / 40")
965013: SPC cable (2m / 80")
USB Input Tool Direct
USB-ITN-E (2m): 06ADV380E
 Connecting cable for **U-Wave-T (160mm)**
02AZD790E
 Refer to page A-13.

Outside Micrometers

SERIES 101

Technical Data

Graduation: .0001"
 Flatness: .000024"
 Parallelism: .00008" for models up to 3"
 .00012" for models over 3"
 Measuring faces: Carbide tipped

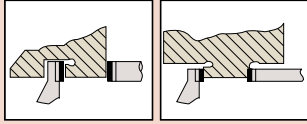

FEATURES

- Satin-chrome-finished frame, tapered (on the anvil side) for hard-to-reach places.
- With a standard bar except for 0 - 1" models.
- Supplied in fitted plastic case.



101-113

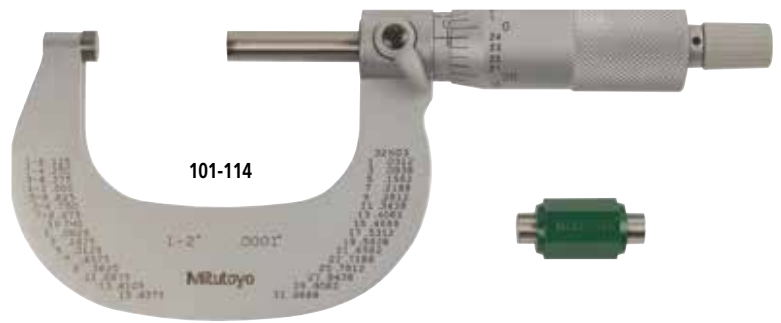

101-114

SPECIFICATIONS

Inch With friction thimble

Range	Graduation	Order No.	Accuracy	Mass (g)
0 - 1"	.0001"	101-117*	±.0001"	180
1 - 2"	.0001"	101-118*	±.0001"	245

*.0001" reading is obtained with vernier.

Inch With ratchet stop

Range	Graduation	Order No.	Accuracy	Mass (g)
0 - 1"	.0001"	101-113*	±.0001"	180
1 - 2"	.0001"	101-114*	±.0001"	245
2 - 3"	.0001"	101-119*	±.0001"	410
3 - 4"	.0001"	101-120*	±.00015"	550

*.0001" reading is obtained with vernier.

DIMENSIONS

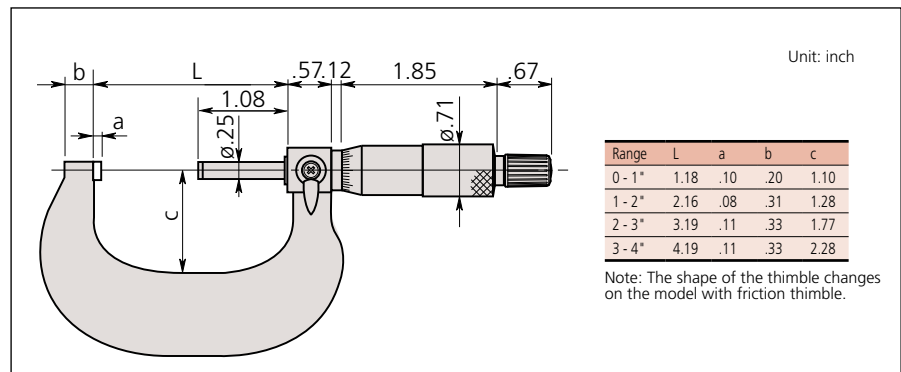

Ratchet Thimble Micrometer

SERIES 101, 102 — New smoother action Ratchet Thimble

FEATURES

- Ratchet function works both from the thimble and the speeder, allowing easy one-handed operation.
- Clearly audible ratchet operation for reassurance that measurement is being performed at constant, preset force.
- Provided with a Certificate of Inspection.
- With a standard bar except for 0 - 25mm and 0 - 1" models.
- Supplied in fitted plastic case.

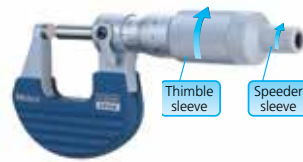

102-701



102-702

SPECIFICATIONS

Metric			
Range	Graduation	Order No.	Accuracy
0 - 25mm	0.01mm	102-701	±2μm
0 - 25mm	0.001mm	102-707*	±2μm
25 - 50mm	0.01mm	102-702	±2μm
25 - 50mm	0.001mm	102-708*	±2μm

*0.001mm reading is obtained with vernier.

Inch			
Range	Graduation	Order No.	Accuracy
0 - 1"	.001"	101-711	±.0001"
	.0001"	101-717*	±.0001"
	.0001"	102-717*	±.0001"
1 - 2"	.0001"	102-718*	±.0001"

*.0001" reading is obtained with vernier.

DIMENSIONS AND MASS

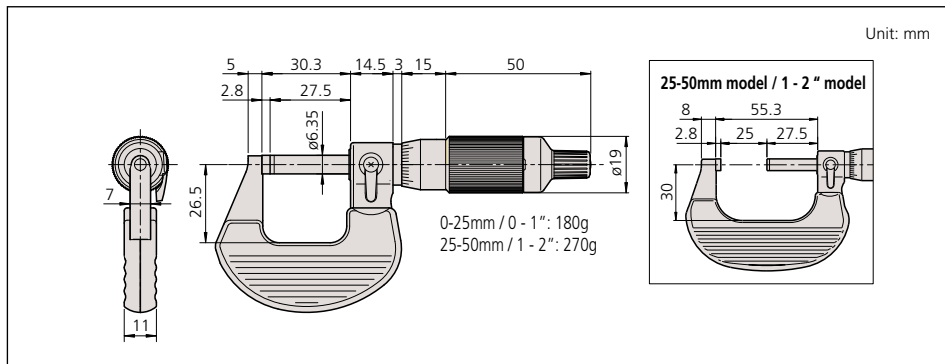

Technical Data

Graduation: 0.01mm, 0.001mm, .001" or .0001"
 Flatness: 0.6μm / .000024"
 Parallelism: 2μm / .00008"
 Measuring faces: Carbide tipped
 Measuring force: 5-10N

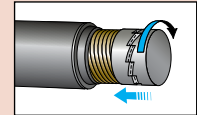

Rotating the thimble/speeder sleeve when the workpiece is between the anvil and spindle causes the ratchet mechanism to tap the spindle and apply a constant measuring force to the workpiece.

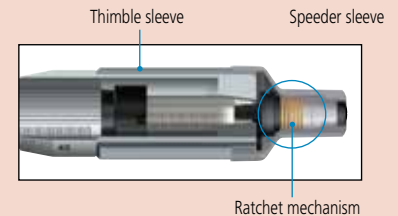



Outside Micrometers

SERIES 102

FEATURES

- Heat-insulated frame, tapered (on the anvil side) for hard-to-reach places.
- With a standard bar except for 0 - 25mm model.
- A ratchet stop for a constant measuring force.
- Supplied in a fitted plastic case.

Technical Data

Graduation: 0.01mm
 Flatness: 0.3μm
 Parallelism: 1μm for 25mm model
 3μm for models up to 100mm
 Measuring faces: Carbide tipped

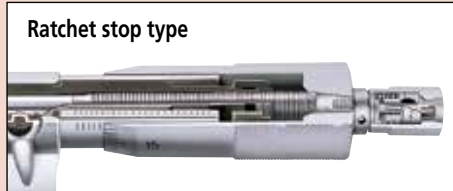

102-301

SPECIFICATIONS

Metric — With ratchet stop

Range	Graduation	Order No.	Accuracy
0 - 25mm	0.01mm	102-301	±2μm
25 - 50mm	0.01mm	102-302	±2μm
50 - 75mm	0.01mm	102-303	±2μm
75 - 100mm	0.01mm	102-304	±3μm

Metric — Micrometer set 0.01mm Graduation model

Range	Order No.	Included in set
0 - 100mm (4 pcs/set)	102-911-40	<ul style="list-style-type: none"> • 102-301 • 102-302 • 102-303 • 102-304 • 3 micrometer standards

DIMENSIONS AND MASS

Unit: mm

Range	L	a	b	c	d	Mass (g)
0 - 25mm	30.3	2.8	5	26	6.35	180
25 - 50mm	55.3	2.8	8	32	6.35	270
50 - 75mm	80.3	2.8	9	45	6.35	375
75 - 100mm	105.3	2.8	10	58	6.35	490

Outside Micrometers

SERIES 103



FEATURES

- Hammertone, baked-enamel-finished frame.
- Ratchet Stop for exact repetitive readings.
- With a standard bar except for 0-25mm model.

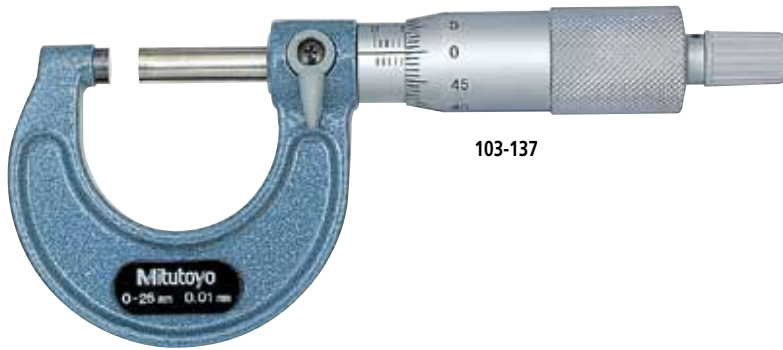

103-137

Technical Data

Graduation: 0.01mm, 0.001mm
 Flatness: 0.6 μm for models up to 300mm/12"
 1 μm for models over 300mm/12"
 Parallelism: (2+R/100)μm, R=max, range (mm)
 Measuring faces: Carbide tipped

SPECIFICATIONS

Metric With ratchet stop

Range	Order No.	Accuracy	Mass (g)
0 - 25mm	103-137	±2μm	175
	103-129*	±2μm	175
25 - 50mm	103-138	±2μm	215
	103-130*	±2μm	215
50 - 75mm	103-139-10	±2μm	315
75 - 100mm	103-140-10	±3μm	375
100 - 125mm	103-141-10	±3μm	515
125 - 150mm	103-142-10	±3μm	665
150 - 175mm	103-143-10	±4μm	720
175 - 200mm	103-144-10	±4μm	920
200 - 225mm	103-145-10	±4μm	1080
225 - 250mm	103-146-10	±5μm	1255
250 - 275mm	103-147-10	±5μm	1405
275 - 300mm	103-148-10	±5μm	1565
300 - 325mm	103-149	±6μm	1985
325 - 350mm	103-150	±6μm	2155
350 - 375mm	103-151	±6μm	2305
375 - 400mm	103-152	±7μm	2455
400 - 425mm	103-153	±7μm	2715
425 - 450mm	103-154	±7μm	2965
450 - 475mm	103-155	±8μm	3215
475 - 500mm	103-156	±8μm	3450

(Models with a range up to 1000mm are available.)

*0.001mm reading is obtained with vernier.

DIMENSIONS AND MASS

Up to 300mm / 12"

Over 300mm / 12"

Range	L	a	b	c
0 - 25mm / 0 - 1"	30.3	2.8	9	28
25 - 50mm / 1 - 2"	55.3	2.8	10	38
50 - 75mm / 2 - 3"	80.3	2.8	12	49
75 - 100mm / 3 - 4"	105.3	2.8	14	60
100 - 125mm / 4 - 5"	132.8	5.3	17	79
125 - 150mm / 5 - 6"	158.2	5.7	19	94
150 - 175mm / 6 - 7"	183.6	6.1	20	106
175 - 200mm / 7 - 8"	208.8	6.3	19	118
200 - 225mm / 8 - 9"	234.2	6.7	18	130
225 - 250mm / 9 - 10"	258	5.5	18	143
250 - 275mm / 10 - 11"	284	6.5	18	156
275 - 300mm / 11 - 12"	309	6.5	18	169

Range	L	a	b	c
300 - 325mm / 12-13"	353	18	28	187
325 - 350mm / 13-14"	378	18	28	199
350 - 375mm / 14-15"	403	18	28	212
375 - 400mm / 15-16"	428	18	28	224
400 - 425mm / 16-17"	453	18	28	236
425 - 450mm / 17-18"	478	18	28	248
450 - 475mm / 18-19"	503	18	28	261
475 - 500mm / 19-20"	528	18	28	273

Metric Micrometer set

Range	Order No.	Included in set	Mass (g)
0 - 75mm (3 pc. set)	103-927-10	103-137, 103-138, 103-139-10, 2 micrometer standards	750
0 - 150mm (6 pc. set)	103-913-50	103-137, 103-138, 103-139-10, 103-140-10, 103-141-10, 103-142-10, 5 micrometer standards	2260
150 - 300mm (6 pc. set)	103-915-10	103-143-10, 103-144-10, 103-145-10, 103-146-10, 103-147-10, 103-148-10, 6 micrometer standards	7695
0 - 300mm (12 pc. set)	103-914-50	All micrometers of 103-913-50 and 103-915-10 in one set, 11 micrometer standards	9300



Outside Micrometers

SERIES 103— Inch Models

FEATURES

- Hammertone, baked-enamel-finished frame.
- Ratchet Stop or Friction Thimble for exact repetitive readings.
- With a standard bar except for 0-1" model.



103-177



103-260

Technical Data (Inch Model)

Accuracy: Refer to the list of specifications.

Graduation: .001" or .0001"

Flatness: .000024" for models up to 12"

.00004" for models over 12"

Parallelism: [.00008 + .00004 (L/4)]" L= max range (inch)

Measuring faces: Carbide tipped

SPECIFICATIONS

Inch _____ With ratchet stop

Range	Graduation	Order No.	Accuracy	Mass (g)
0 - 1"	.001"	103-177	±.0001"	175
1 - 2"	.001"	103-178	±.0001"	215
2 - 3"	.001"	103-179	±.0001"	315
3 - 4"	.001"	103-180	±.00015"	375
4 - 5"	.001"	103-181	±.00015"	515
5 - 6"	.001"	103-182	±.00015"	665
6 - 7"	.001"	103-183	±.0002"	720
7 - 8"	.001"	103-184	±.0002"	920
8 - 9"	.001"	103-185	±.0002"	1080
9 - 10"	.001"	103-186	±.00025"	1255
10 - 11"	.001"	103-187	±.00025"	1405
11 - 12"	.001"	103-188	±.00025"	1565
12 - 13"	.001"	103-189	±.0003"	1985
13 - 14"	.001"	103-190	±.0003"	2155
14 - 15"	.001"	103-191	±.0003"	2305
15 - 16"	.001"	103-192	±.00035"	2455
16 - 17"	.001"	103-193	±.00035"	2715
17 - 18"	.001"	103-194	±.00035"	2965
18 - 19"	.001"	103-195	±.0004"	3215
19 - 20"	.001"	103-196	±.0004"	3450
20 - 21"	.001"	103-197	±.0004"	4060
21 - 22"	.001"	103-198	±.00045"	4080
22 - 23"	.001"	103-199	±.00045"	4500
23 - 24"	.001"	103-200	±.00045"	4525
24 - 25"	.001"	103-201	±.0005	4915
25 - 26"	.001"	103-202	±.0005"	4930
26 - 27"	.001"	103-203	±.0005"	5200
27 - 28"	.001"	103-204	±.00055"	5215
28 - 29"	.001"	103-205	±.00055"	5835
29 - 30"	.001"	103-206	±.00055"	5860
30 - 31"	.001"	103-207	±.0006"	6385
31 - 32"	.001"	103-208	±.0006"	6410
32 - 33"	.001"	103-209	±.0006"	6925
33 - 34"	.001"	103-210	±.00065"	6940
34 - 35"	.001"	103-211	±.00065"	7565
35 - 36"	.001"	103-212	±.00065"	7590
36 - 37"	.001"	103-213	±.0007"	8215
37 - 38"	.001"	103-214	±.0007"	8240
38 - 39"	.001"	103-215	±.0007"	8860
39 - 40"	.001"	103-216	±.00075"	8880

Inch _____ With friction thimble

Range	Graduation	Order No.	Accuracy	Mass (g)
0 - 1"	.001"	103-127	±.0001"	175
	.0001"	103-135*	±.0001"	175
1 - 2"	.001"	103-128	±.0001"	215
	.0001"	103-136*	±.0001"	215

* .0001" Reading is obtained with vernier

Inch _____ With ratchet stop

Range	Graduation	Order No.	Accuracy	Mass (g)
0 - 1"	.0001"	103-131*	±.0001"	175
1 - 2"	.0001"	103-132*	±.0001"	215
2 - 3"	.0001"	103-217*	±.0001"	315
3 - 4"	.0001"	103-218*	±.00015"	375
4 - 5"	.0001"	103-219*	±.00015"	515
5 - 6"	.0001"	103-220*	±.00015"	665
6 - 7"	.0001"	103-221*	±.0002"	720
7 - 8"	.0001"	103-222*	±.0002"	920
8 - 9"	.0001"	103-223*	±.0002"	1080
9 - 10"	.0001"	103-224*	±.00025"	1255
10 - 11"	.0001"	103-225*	±.00025"	1405
11 - 12"	.0001"	103-226*	±.00025"	1565

* .0001" Reading is obtained with vernier

Inch _____ With Tapered Frame and Ratchet Stop

Range	Graduation	Order No.	Accuracy	Mass (g)
0-1"	.001"	103-259	±.0001"	175
0-1"	.0001"	103-260*	±.0001"	175
1-2"	.0001"	103-262*	±.0001"	215

* .0001" Reading is obtained with vernier

Outside Micrometers

SERIES 103 — Inch model set

Inch		Micrometer Set .001" Graduation Model	
Range	Order No.	Included in set	Mass (g)
0 - 3" (3pcs./set)	103-929	103-177, 103-178, 103-179, 2 Micrometer Standards	750
0 - 4" (4pcs./set)	103-930	103-177, 103-178, 103-179, 103-180, 3 Micrometer Standards	1600
0 - 6" (6pcs./set)	103-904-10	103-177, 103-178, 103-179, 103-180, 103-181, 103-182, 5 Micrometer Standards	2200
0 - 12" (12pcs./set)	103-905-10	103-177, 103-178, 103-179, 103-180, 103-181, 103-182, 103-183, 103-184, 103-185, 103-186, 103-187, 103-188, 11 Micrometer Standards	9000
6 - 12" (6pcs./set)	103-906	103-183, 103-184, 103-185, 103-186, 103-187, 103-188, 6 Micrometer Standards	7695



103-905-10

Inch		Micrometer Set .0001" Graduation Model	
Range	Order No.	Included in set	Mass (g)
0 - 3" (3pcs./set)	103-922	103-135, 103-136, 103-217, 2pcs. Micrometer Standards	705
0 - 4" (4pcs./set)	103-931	103-135, 103-136, 103-217, 103-218, 3pcs. Micrometer Standards	1600
0 - 6" (6pcs./set)	103-907-40	103-135, 103-136, 103-217, 103-218, 103-219, 103-220, 5 Micrometer Standards	2200
0 - 12" (12pcs./set)	103-908-40	103-135, 103-136, 103-217, 103-218, 103-219, 103-220, 103-221, 103-222, 103-223, 103-224, 103-225, 103-226, 11pcs. Micrometer Standards	9000
6 - 12" (6pcs./set)	103-909	103-221, 103-222, 103-223, 103-224, 103-225, 103-226, 6pcs. Micrometer Standards	6945



103-904-10



Outside Micrometers

SERIES 340, 104 — with Interchangeable Anvils, Inch model

FEATURES

- IP65 water/dust protection (Series 340*).
*Models with a range up to 12" / 300mm.
- Wide measuring range with interchangeable anvils.
- With a Ratchet Stop for constant force.
- Supplied with zero-setting standards bar for each range.
- With SPC output (Series 340).
- Supplied in fitted wooden case.

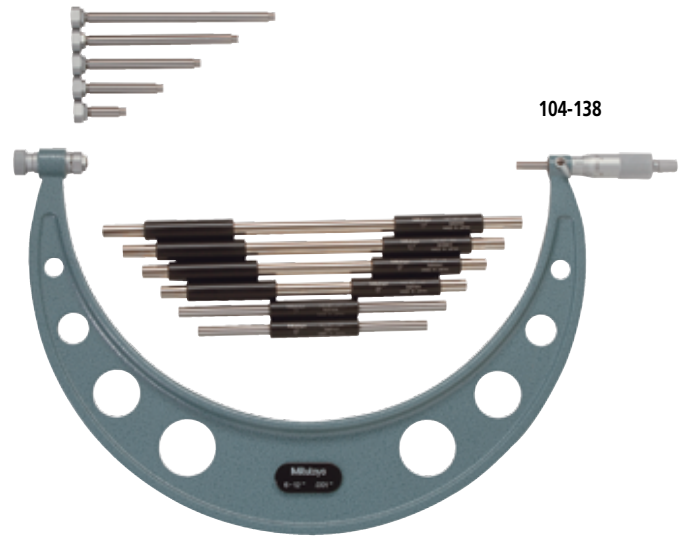

Technical Data

Accuracy: $\pm[.00016'' + .00004 (L/3)]$ L = Max Range (Inch)
 Resolution*: .0001" / 0.001mm
 (340-351-10: .00005" / 0.001mm)
 Graduation***: .001" (104-165: is .0001")
 Flatness: .000024" for models up to 12"
 .00004" for models over 12"
 Parallelism: .00008" for models up to 3"
 .00012" for models up to 6"
 $\pm[.00008'' + .00004 (L/4)]$ L = Max range (inch)
 Measuring faces: Carbide tipped (spindle only)
 Display*: LCD
 Battery*: SR44 (1 pc.), **938882**
 Battery life*: Approx. 1.2 years under normal use
 Dust/Water protection level*: IP65 (up to 12" / 300mm)
 *Digital models **Analog models

Function of Digital Model

Zero / ABS, Data hold, Preset, Data output, inch/mm conversion (on inch/metric models only)
 Alarm: Low voltage, Counting value composition error
 Function Lock***
 2 Presets***
 *** 4 - 12" / 100 - 300mm Models

Optional Accessories for Digital Model

05CZA662: SPC cable with data switch (40" / 1m)
05CZA663: SPC cable with data switch (80" / 2m)



SPECIFICATIONS

Inch/Metric		Digital model			
Range	Resolution	Order No.	Mass (kg)	Remarks	
0-6" / 0-152.4mm	.00005" / 0.001mm	340-351-10	0.96	with 6 anvils & 5 standards	
6-12" / 152.4 - 304.8mm	.0001" / 0.001mm	340-352-10	1.88	with 6 anvils & 6 standards	
12-18" / 304.8 - 457.2mm	.0001" / 0.001mm	340-720	4.75	with 6 anvils & 6 standards	
18-24" / 457.2 - 609.6mm	.0001" / 0.001mm	340-721	6.62	with 6 anvils & 6 standards	
24-30" / 609.6 - 762.0mm	.0001" / 0.001mm	340-722	10.06	with 6 anvils & 6 standards	
30-36" / 762.0 - 914.4mm	.0001" / 0.001mm	340-723	11.98	with 6 anvils & 6 standards	

Inch					
Range	Graduation	Order No.	Mass(kg)	Remarks	
0-2"	.0001"	104-165*	0.32	with 1" anvil & 1 standard	
0-6"	.001"	104-137	1.35	with 6 anvils & 5 standards	
6-12"	.001"	104-138	2.65	with 6 anvils & 6 standards	
12-16"	.001"	104-152	3.31	with 4 anvils & 4 standards	
12-18"	.001"	104-201	4.69	with 6 anvils & 6 standards	
16-20"	.001"	104-153	4.81	with 4 anvils & 4 standards	
18-24"	.001"	104-202	6.51	with 6 anvils & 6 standards	
20-24"	.001"	104-154	6.35	with 4 anvils & 4 standards	
24-28"	.001"	104-155	7.72	with 4 anvils & 4 standards	
24-30"	.001"	104-203	9.95	with 6 anvils & 6 standards	
28-32"	.001"	104-156	9.08	with 4 anvils & 4 standards	
30-36"	.001"	104-204	11.87	with 6 anvils & 6 standards	
32-36"	.001"	104-157	10.41	with 4 anvils & 4 standards	
36-40"	.001"	104-158	11.78	with 4 anvils & 4 standards	
36-42"	.001"	104-205	13.68	with 6 anvils & 6 standards	

*.0001" reading is obtained with vernier.

Outside Micrometers

SERIES 340, 104 — with Interchangeable Anvils, Metric Model



FEATURES

- IP65 water/dust protection (Series 340*).
*Models with a range up to 300mm.
- Wide measuring range with interchangeable anvils.
- With a Ratchet Stop for constant force.
- Supplied with zero-setting standards bar for each range.
- With SPC output (Series 340).
- Supplied in fitted wooden case.

Digital model



SPECIFICATIONS

Metric Digital model

Range	Resolution	Order No.	Mass (kg)	Remarks
0 - 150mm	0.001mm	340-251-10	0.96	with 6 anvils & 5 standards
150 - 300mm	0.001mm	340-252-10	1.88	with 6 anvils & 6 standards
300 - 400mm	0.001mm	340-520	3.31	with 4 anvils & 4 standards
400 - 500mm	0.001mm	340-521	4.81	with 4 anvils & 4 standards
500 - 600mm	0.001mm	340-522	6.35	with 4 anvils & 4 standards
600 - 700mm	0.001mm	340-523	7.72	with 4 anvils & 4 standards
700 - 800mm	0.001mm	340-524	9.08	with 4 anvils & 4 standards
800 - 900mm	0.001mm	340-525	10.41	with 4 anvils & 4 standards
900 - 1000mm	0.001mm	340-526	11.78	with 4 anvils & 4 standards

Metric

Range	Graduation	Order No.	Mass (kg)	Remarks
0 - 50mm	0.01mm	104-171*	0.32	with 2 anvils & 1 standards
0 - 100mm	0.01mm	104-139A	0.79	with 4 anvils & 3 standards
0 - 150mm	0.01mm	104-135A	1.35	with 6 anvils & 5 standards
50 - 150mm	0.01mm	104-161A	1.35	with 4 anvils & 4 standards
100 - 200mm	0.01mm	104-140A	1.38	with 4 anvils & 4 standards
150 - 300mm	0.01mm	104-136A	2.65	with 6 anvils & 6 standards
200 - 300mm	0.01mm	104-141A	2.22	with 4 anvils & 4 standards
300 - 400mm	0.01mm	104-142A	3.31	with 4 anvils & 4 standards
400 - 500mm	0.01mm	104-143A	4.81	with 4 anvils & 4 standards
500 - 600mm	0.01mm	104-144A	6.35	with 4 anvils & 4 standards
600 - 700mm	0.01mm	104-145A	7.72	with 4 anvils & 4 standards
700 - 800mm	0.01mm	104-146A	9.08	with 4 anvils & 4 standards
800 - 900mm	0.01mm	104-147A	10.41	with 4 anvils & 4 standards
900 - 1000mm	0.01mm	104-148A	11.78	with 4 anvils & 4 standards

*The frame is in a heat insulated cover

DIMENSIONS

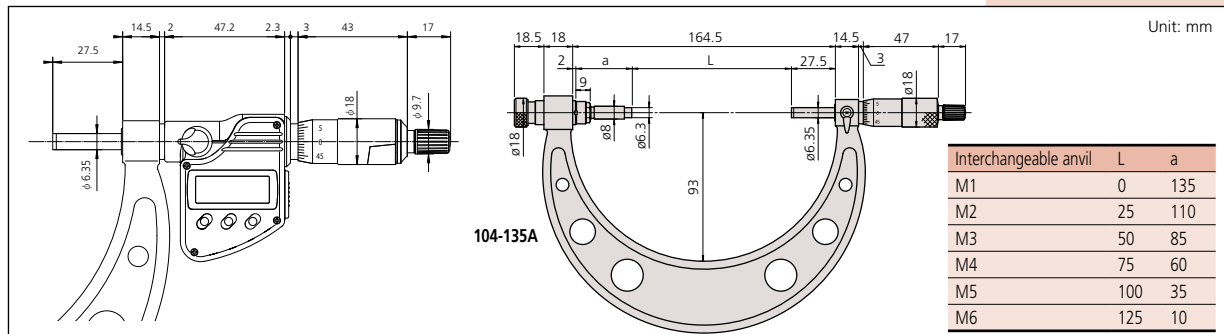

Technical Data

Accuracy: $\pm(4+R/75)\mu\text{m}$, R=max. range (mm)
 Resolution*: 0.001mm
 Graduation***: 0.01mm
 Flatness: 0.6 μm for models up to 300mm
 1 μm for models over 300mm
 Parallelism: 2 μm for models up to 75mm
 3 μm for models up to 150mm
 (2+R/100) μm for models over 150mm, R=max. range (mm)

Measuring faces: Carbide tipped (spindle only)

Display*: LCD

Battery*: SR44 (1 pc.), **938882**

Battery life*: Approx. 1.2 years under normal use

Dust/Water protection level*: IP65 (up to 300mm)

*Digital models **Analog models

Function of Digital Model

Zero / ABS, Data hold, Preset, Data output, inch/mm conversion (on inch/metric models only)
 Alarm: Low voltage, Counting value composition error
 Function Lock***
 2 Presets***
 ***4 - 12" / 100 - 300mm Models

Optional Accessories for Digital Model

05CZA662: SPC cable with data switch (40" / 1m)

05CZA663: SPC cable with data switch (80" / 2m)

Outside Micrometers

SERIES 105 — with Extension Anvil Collars

Technical Data

Accuracy: $\pm(6+R/75)\mu\text{m}$, R=max. range (mm)
 Graduation: .001" / 0.01mm
 Flatness: .000052" / 1.3 μm
 Parallelism: [.00016" + .00004 (L/4)"] L=max. range (inch)
 (2+R/100) μm , R=max. range (mm)
 Measuring faces: Carbide tipped

Extension anvil collar



FEATURES

- Wide measuring range with extension anvil collars.
- 50mm spindle stroke.
- With Ratchet Stop for constant force.
- Supplied with zero-setting standards bar for each range.
- Square and round pipes are combined for light weight and rigid frame (for models over 1000mm range).
- Workpiece stopper (for models over 1000mm range).
- Supplied in a fitted wooden case.

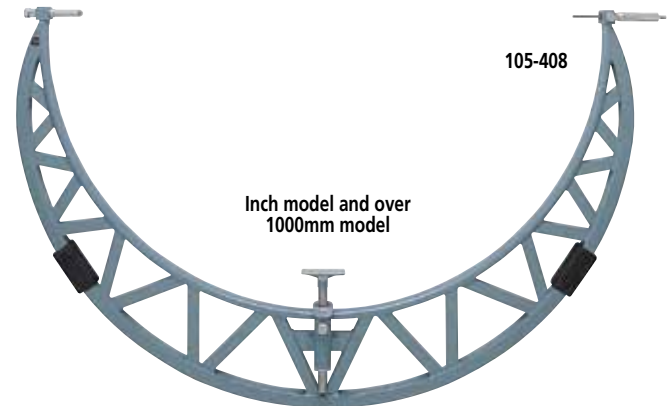
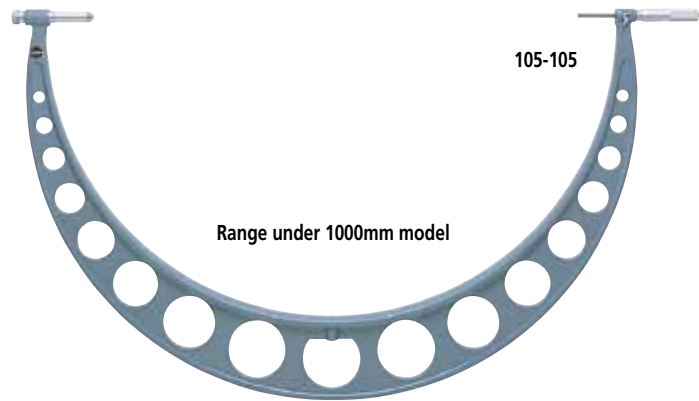

SPECIFICATIONS

Metric

Range	Order No.	Extension collars	Mass (kg)
500 - 600mm	105-103	50mm	5.53
600 - 700mm	105-104	50mm	6.35
700 - 800mm	105-105	50mm	7.17
800 - 900mm	105-106	50mm	7.99
900 - 1000mm	105-107	50mm	8.81
1000 - 1100mm	105-408	50mm	6.37
1100 - 1200mm	105-409	50mm	7.08
1000 - 1200mm	105-418	50mm, 100mm	13.77
1200 - 1300mm	105-410	50mm	7.79
1300 - 1400mm	105-411	50mm	8.50
1200 - 1400mm	105-419	50mm, 100mm	15.77
1400 - 1500mm	105-412	50mm	9.21
1500 - 1600mm	105-413	50mm	10.17
1400 - 1600mm	105-420	50mm, 100mm	17.91
1600 - 1700mm	105-414	50mm	11.13
1700 - 1800mm	105-415	50mm	12.09
1600 - 1800mm	105-421	50mm, 100mm	20.80
1800 - 1900mm	105-416	50mm	13.05
1900 - 2000mm	105-417	50mm	14.01
1800 - 2000mm	105-422	50mm, 100mm	22.76

Inch

Range	Order No.	Extension collars	Mass (kg)
40 - 44"	105-428	2"	10.0
44 - 48"	105-429	2"	10.9
48 - 52"	105-430	2"	11.4
52 - 56"	105-431	2"	11.9
56 - 60"	105-432	2"	12.6
60 - 64"	105-433	2"	13.2
64 - 68"	105-434	2"	14.1
68 - 72"	105-435	2"	14.9
72 - 76"	105-436	2"	15.8
76 - 80"	105-437	2"	16.7

Outside Micrometers

SERIES 406 — Non-Rotating Spindle Type

FEATURES

- With a standard bar except for 0 - 1" / 0 - 25mm model.
- With SPC output.
- Supplied in a fitted plastic case.



406-350

SPECIFICATIONS

Metric		Digital model with ratchet stop	
Range	Resolution	Order No.	Accuracy
0 - 25mm	0.001mm	406-250	±3μm
25 - 50mm	0.001mm	406-251	±3μm
50 - 75mm	0.001mm	406-252	±3μm
75 - 100mm	0.001mm	406-253	±4μm

Inch/Metric		Digital model with ratchet stop	
Range	Resolution	Order No.	Accuracy
0 - 1" / 0 - 25.4mm	.00005" / 0.001mm	406-350	±.00015"
1 - 2" / 25.4 - 50.8mm	.00005" / 0.001mm	406-351	±.00015"
2 - 3" / 50.8 - 72.6mm	.00005" / 0.001mm	406-352	±.00015"
3 - 4" / 76.2 - 101.6mm	.00005" / 0.001mm	406-353	±.0002"

DIMENSIONS AND MASS

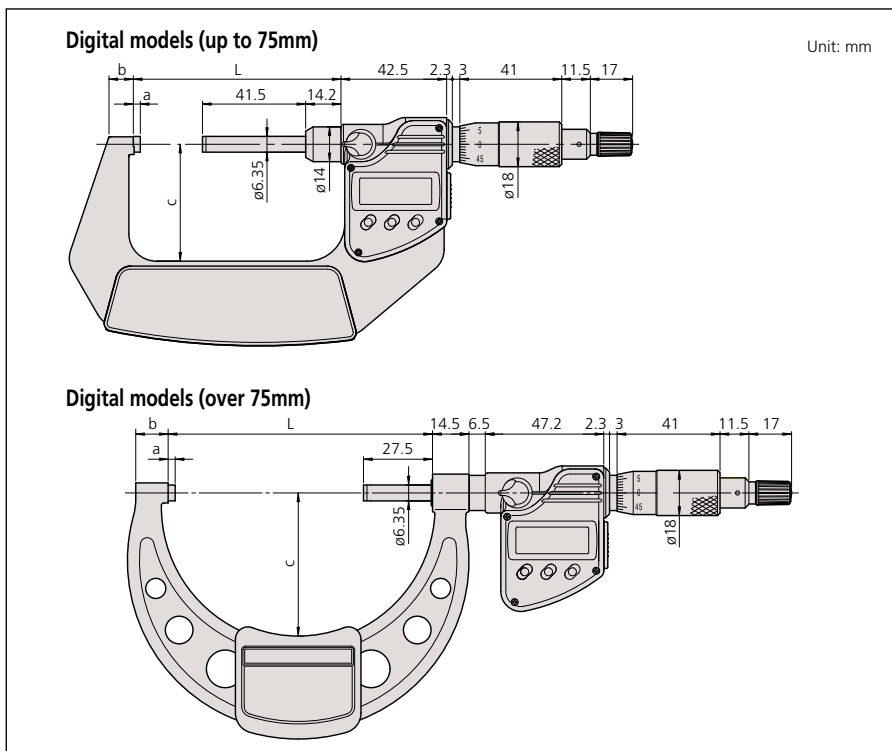

Technical Data

Accuracy: Refer to the list of specifications.
 Resolution: .00005"/0.001mm or 0.001mm
 Flatness: 0.3μm / .000012"
 Parallelism: .00012" / 3μm for models up to 3" / 75mm*
 .000016" / 4μm for models over 3" / 75mm*
 .000063" / 1.6μm for models up to 2" / 50mm**
 2μm for models over 50mm**

Measuring faces: Carbide tipped
 Display*: LCD
 Battery*: SR44 (1 pc.), **938882**
 Battery life*: Approx. 1.2 years under normal use

Function of Digital Model

Origin-set, Zero / ABS, Data hold, Data output, inch/mm conversion (on inch/metric models only)
 Alarm: Low voltage, Counting value composition error

Optional Accessories for Digital Model

05CZA662: SPC cable with data switch (40" / 1m)
05CZA663: SPC cable with data switch (80" / 2m)

Outside Micrometers

SERIES 107

FEATURES

- Uses dial indicator for direct GO/NG-GO judgment for mass-produced parts.
- Anvil retracting trigger for quick measurement.
- With a standard bar except for 0 - 25mm models.
- Supplied in fitted plastic case.

Technical Data

Graduation: 0.01mm (thimble)
 Flatness: 0.6 μ m
 Parallelism: (2+R/100) μ m, R=max. range (mm)
 Measuring faces: Carbide tipped

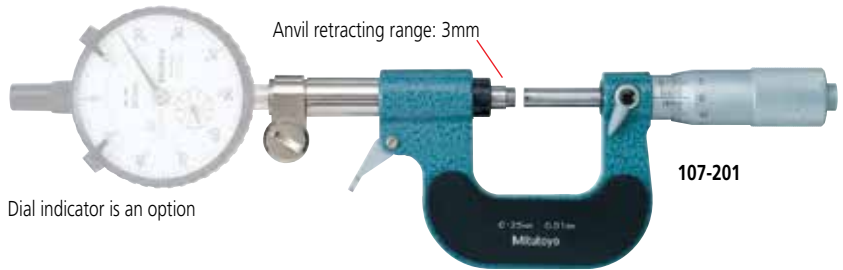

Dial indicator is an option

SPECIFICATIONS

Metric			
Range	Graduation	Order No.	Accuracy
0 - 25mm	0.01mm	107-201	$\pm 2\mu$ m
25 - 50mm	0.01mm	107-202	$\pm 2\mu$ m
50 - 75mm	0.01mm	107-203	$\pm 2\mu$ m
75 - 100mm	0.01mm	107-204	$\pm 3\mu$ m
100 - 125mm	0.01mm	107-205	$\pm 3\mu$ m
125 - 150mm	0.01mm	107-206	$\pm 3\mu$ m
150 - 175mm	0.01mm	107-207	$\pm 4\mu$ m
175 - 200mm	0.01mm	107-208	$\pm 4\mu$ m

DIMENSIONS AND MASS

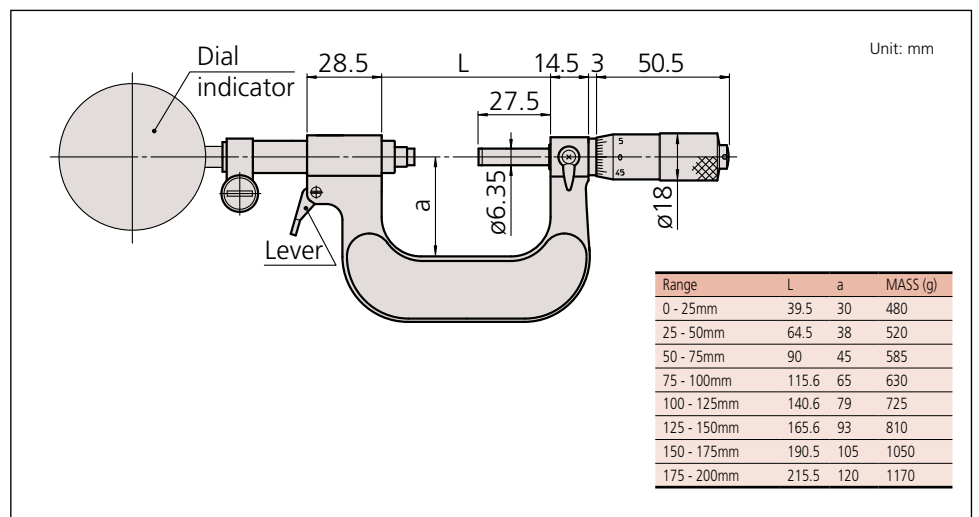

Spline Micrometers

SERIES 331, 111



FEATURES

- IP65 water/dust protection (Series 331).
- The anvil and spindle have a small diameter for measuring splined shafts, slots, and keyways.
- With Ratchet Stop for constant force.
- With SPC output (Series 331).
- With a standard bar except 0-1" and 0-25mm model.
- Supplied in fitted plastic case.



331-351



111-115

Technical Data

Accuracy: Refer to the list of specifications.
 Resolution*: .00005"/0.001mm or 0.001mm
 Graduation**: .0001" or 0.01mm, .001"
 Flatness: .000012" / 0.3µm
 Parallelism: (2+R/100)µm, R=max. range (mm)
 [.00008" + .00004" (L/4")]
 L = max. range (inch)
 Measuring faces: Carbide tipped
 Display*: LCD
 Battery*: SR44 (1 pc.), **938882**
 Battery life*: Approx. 1.2 years under normal use
 Dust/Water protection level*: IP65
 *Digital models **Analog models

Function of Digital Model

Origin-set, Zero-setting, Data hold, Data output, inch/mm conversion (on inch/metric models only)
 Alarm: Low voltage, Counting value composition error

Optional Accessories for Digital Model

05CZA662: SPC cable with data switch (40" / 1m)
05CZA663: SPC cable with data switch (80" / 2m)

SPECIFICATIONS

Metric	Digital model				
Range	Resolution	Order No.	Accuracy	Remarks	Mass (g)
0 - 25mm	0.001mm	331-251	±2µm	Type A	330
		331-261	±2µm	Type B	330
25 - 50mm	0.001mm	331-252	±2µm	Type A	470
		331-262	±2µm	Type B	470
50 - 75mm	0.001mm	331-253	±2µm	Type A	625
		331-263	±2µm	Type B	625
75 - 100mm	0.001mm	331-254	±3µm	Type A	565
		331-264	±3µm	Type B	565

Inch/Metric	Digital model				
Range	Resolution	Order No.	Accuracy	Remarks	Mass (g)
0 - 1" / 0 - 25.4mm	.00005" / 0.001mm	331-351	±.0001"	Type A	330
		331-361	±.0001"	Type B	330
1 - 2" / 25.4-50.8mm	.00005" / 0.001mm	331-352	±.0001"	Type A	470
		331-362	±.0001"	Type B	470
2 - 3" / 50.8-76.2mm	.00005" / 0.001mm	331-353	±.0001"	Type A	625
		331-363	±.0001"	Type B	625
3 - 4" / 76.2-101.6mm	.00005" / 0.001mm	331-354	±.00015"	Type A	565
		331-364	±.00015"	Type B	565

Metric					
Range	Graduation	Order No.	Accuracy	Remarks	Mass (g)
0 - 25mm	0.01mm	111-115	±3µm	Type A	205
		111-215	±3µm	Type B	205
25 - 50mm	0.01mm	111-116	±3µm	Type A	305
		111-117	±3µm	Type A	370
50 - 75mm	0.01mm	111-117	±3µm	Type A	370
		111-118	±4µm	Type A	500
75 - 100mm	0.01mm	111-118	±4µm	Type A	500
		111-119	±4µm	Type A	655
100 - 125mm	0.01mm	111-119	±4µm	Type A	655
		111-120	±4µm	Type A	710
125 - 150mm	0.01mm	111-120	±4µm	Type A	710
		111-121	±5µm	Type A	900
150 - 175mm	0.01mm	111-121	±5µm	Type A	900
		111-122	±5µm	Type A	1040
175 - 200mm	0.01mm	111-122	±5µm	Type A	1040

Inch					
Range	Graduation	Order No.	Accuracy	Remarks	Mass (g)
0 - 1"	.0001"	111-166*	±.00015"	Type A	205

*.0001" reading is obtained with vernier.

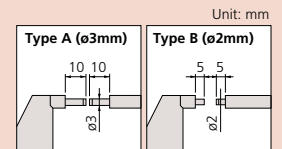

DIMENSIONS

Models up to 75mm

Digital model

Models over 75mm

Digital model

Range	L	a	b	c
0 - 25mm	58.2 (55.3)	17.5 (17.8)	7.3 (10)	32 (38)
25 - 50mm	83.2 (80.3)	17.5 (17.8)	10.1 (12)	47 (49)
50 - 75mm	108.2 (105.3)	20.3 (17.8)	11.5 (14)	60 (60)
75 - 100mm	132.8 (132.8)	20.3 (20.3)	16.7 (17)	76.5 (79)

Point Micrometers

SERIES 342, 142, 112

FEATURES

- IP65 water/dust protection (Series 342).
- Pointed spindle and anvil for measuring the web thickness of drills, small grooves, keyways, and other hard-to-reach dimensions.
- 15 degree and 30 degree measuring points are available.
- The measuring points have approximately 0.3mm / .012" radius.
- With Ratchet Stop for constant force.
- With SPC output (Series 342).
- With digit counter (Series 142).
- With a standard bar except 0 - 1" and 0 - 25mm model.
- Supplied in fitted plastic case.

Technical Data

Accuracy: Refer to the list of specifications.
 Resolution*: .00005"/0.001mm or 0.001mm
 Graduation**: .001" or 0.01mm
 Display*: LCD
 Battery*: SR44 (1 pc.), **938882**
 Battery life*: Approx. 1.2 years under normal use
 Dust/Water protection level*: IP65
 *Digital models **Analog models

Function of Digital Model

Origin-set, Zero / ABS, Data hold, inch/mm conversion (on inch/metric models only)
 Alarm: Low voltage, Counting value composition error

Optional Accessories for Digital Model

- 05CZA662:** SPC cable with data switch (40" / 1m)
- 05CZA663:** SPC cable with data switch (80" / 2m)



342-351



112-201



Tip angle: 15° (R0.3mm)



Tip angle: 30° (R0.3mm)



SPECIFICATIONS

Metric Digital model (with carbide tip)					
Range	Resolution	Order No.	Accuracy	Point	Mass (g)
0 - 25mm	0.001mm	342-251	±2µm	15°	330
		342-261	±2µm	30°	330
25 - 50mm	0.001mm	342-252	±2µm	15°	470
		342-262	±2µm	30°	470
50 - 75mm	0.001mm	342-253	±2µm	15°	625
		342-263	±2µm	30°	625
75 - 100mm	0.001mm	342-254	±3µm	15°	565
		342-264	±3µm	30°	565

Metric Mechanical Counter Model					
Range	Graduation	Order No.	Accuracy	Point	Mass (g)
0 - 25mm	0.01mm	142-153*	±3µm	15°	260
		142-201*	±3µm	30°	260

Metric Mechanical Counter Model					
Range	Graduation	Order No.	Accuracy	Point	Mass (g)
0 - 25mm	0.01mm	112-165	±3µm	15°	205
		112-153*	±3µm	15°	205
		112-213	±3µm	30°	205
		112-201*	±3µm	30°	205
25 - 50mm	0.01mm	112-166	±3µm	15°	305
		112-154*	±3µm	15°	305
		112-214	±3µm	30°	305
		112-202*	±3µm	30°	305
50 - 75mm	0.01mm	112-167	±3µm	15°	370
		112-155*	±3µm	15°	370
		112-215	±3µm	30°	370
		112-203*	±3µm	30°	370
75 - 100mm	0.01mm	112-168	±4µm	15°	500
		112-156*	±4µm	15°	500
		112-216	±4µm	30°	500
		112-204*	±4µm	30°	500

*The points don't have carbide tips.

Inch/Metric Digital model (with carbide tip)					
Range	Resolution	Order No.	Accuracy	Point	Mass (g)
0 - 1" / 0 - 25.4mm	.00005" / 0.001mm	342-351	±.0001"	15°	330
		342-361	±.0001"	30°	330
1" - 2" / 25.4 - 50.8mm	.00005" / 0.001mm	342-352	±.0001"	15°	470
		342-362	±.0001"	30°	470
2" - 3" / 50.8 - 76.2mm	.00005" / 0.001mm	342-353	±.0001"	15°	625
		342-363	±.0001"	30°	625
3" - 4" / 76.2 - 101.6mm	.00005" / 0.001mm	342-354	±.00015"	15°	565
		342-364	±.00015"	30°	565

Inch Mechanical Counter Model					
Range	Graduation	Order No.	Accuracy	Point	Mass (g)
0 - 1"	.001"	142-177*	±.00015"	15°	260
		142-225*	±.00015"	30°	260

Inch Mechanical Counter Model					
Range	Graduation	Order No.	Accuracy	Point	Mass (g)
0 - 1"	.001"	112-189	±.00015"	15°	205
		112-177*	±.00015"	15°	205
		112-237	±.00015"	30°	205
		112-225*	±.00015"	30°	205
1 - 2"	.001"	112-190	±.00015"	15°	305
		112-178*	±.00015"	15°	305
		112-238	±.00015"	30°	305
		112-226*	±.00015"	30°	305
2 - 3"	.001"	112-191	±.00015"	15°	370

*The points don't have carbide tips.

DIMENSIONS

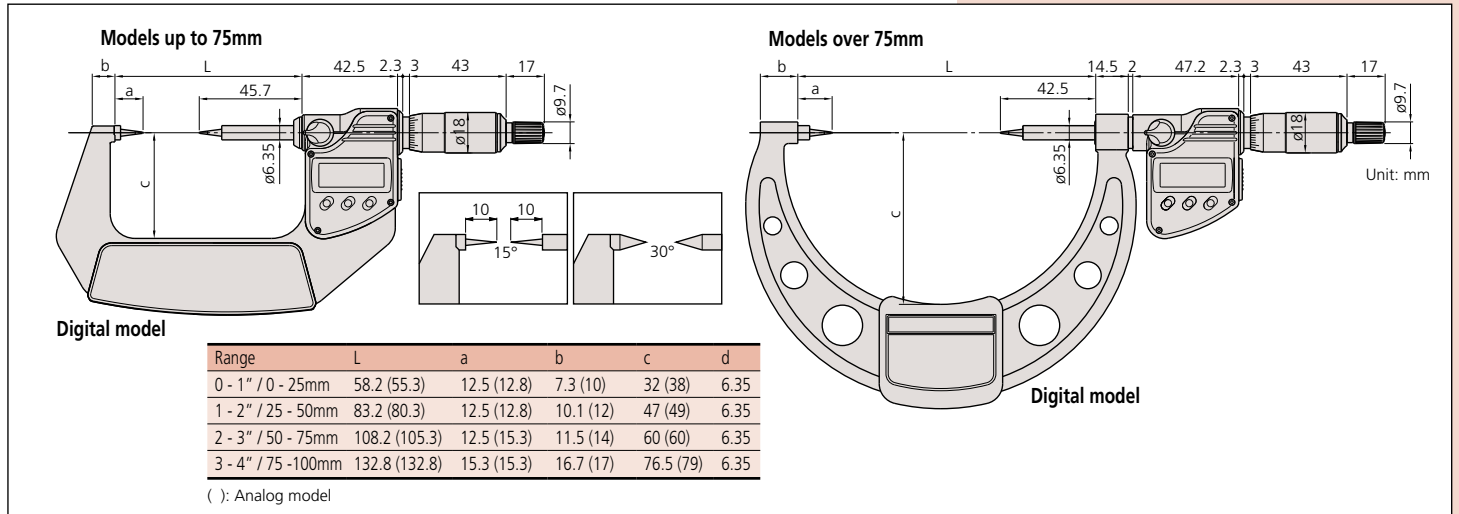

Crimp Height Micrometers

SERIES 342, 142, 112 — Point Spindle and Blade Anvil

FEATURES

- IP54/65 water/dust protection (Series 342).
- Measures the height of crimp contacts.
- With Ratchet Stop for constant force.
- With SPC output (Series 342).
- With digit counter (Series 142).
- Supplied in fitted plastic case.

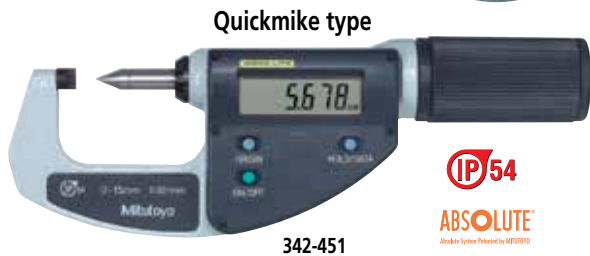

SPC



IP65

Technical Data

Accuracy: Refer to the list of specifications.
 Resolution*: .00005" / 0.001mm or 0.001mm
 Graduation**: 0.01mm
 Display*: LCD
 Battery*: SR44 (1 pc.), **938882**
 Battery life*: Approx. 1.2 years under normal use
 (3 years: Quickmike type)
 Dust/Water protection level*: IP65 / IP54
 *Digital models **Analog models

Function of Digital Model

Origin-set, Zero / ABS (342-271 342-371), Data hold, Data output, inch/mm conversion (on inch/metric models only)
 Alarm: Low voltage, Counting value composition error

Optional Accessories for Digital Model

- 05CZA662**: SPC cable with data switch (40" / 1m)
- 05CZA663**: SPC cable with data switch (80" / 2m)
- 937387**: SPC cable for Quickmike type (40" / 1m)
- 965013**: SPC cable for Quickmike type (80" / 2m)

SPECIFICATIONS

Metric		Digital model			
Range	Resolution	Order No.	Accuracy	Mass (g)	
0 - 20mm	0.001mm	342-271	±3µm	270	

Metric		Quickmike type			
Range	Resolution	Order No.	Accuracy	Mass (g)	
0 - 15mm	0.001mm	342-451	±3µm	275	

Metric		Mechanical counter model			
Range	Graduation	Order No.	Accuracy	Mass (g)	
0 - 25mm	0.01mm	142-402	±3µm	200	
0 - 25mm	0.001mm	142-403*	±3µm	200	

Inch/Metric		Digital model			
Range	Resolution	Order No.	Accuracy	Mass (g)	
0 - 0.8" / 0 - 20mm	.00005" / 0.001mm	342-371	±.00015"	270	

Metric					
Range	Graduation	Order No.	Accuracy	Mass (g)	
0 - 25mm	0.01mm	112-401	±3µm	165	

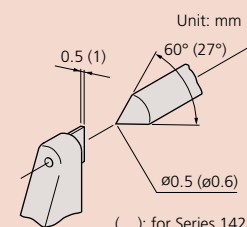

* 0.001mm reading is obtained with vernier.



V-Anvil Micrometers

SERIES 314, 114 — 3 Flutes and 5 Flutes

Technical Data

Accuracy: Refer to the list of specifications.
 Resolution*: .00005" / 0.001mm or 0.001mm
 Graduation**: .001" or .0001", 0.01mm
 Flatness (spindle/anvil):
 Analog model: .000024" / 0.6µm, .00005" / 1.3µm
 Digital Model: .000012" / 0.3µm, .00004" / 1µm
 Spindle face: Carbide tipped
 Display*: LCD
 Battery*: SR44 (1 pc.), **938882**
 Battery life*: Approx. 1.2 years under normal use
 *Digital models **Analog models

Function of Digital Model

Zero / ABS, Data hold, Data output, Preset, inch/mm conversion (on inch/metric models only)
 Alarm: Low voltage, Counting value composition error
 Function lock
 2 Presets

Optional Accessories for Digital Model

05CZA662: SPC cable with data switch (40" / 1m)
05CZA663: SPC cable with data switch (80" / 2m)

FEATURES

- Measures the outside diameter of cutting tools (such as taps, reamers, end mills) with an odd number of flutes.
- With Ratchet Stop for constant force.
- Supplied with setting standard.
- V-anvils with a centerline groove are available. They are useful for measuring pitch diameters of taps which have a small diameter by using single-wire method.
- With SPC output (Series 314).
- Supplied in fitted plastic case.



314-351-10



114-121



114-202



114-204

Pitch Diameter Measurement of Tap by Single-wire Method Inch/Metric

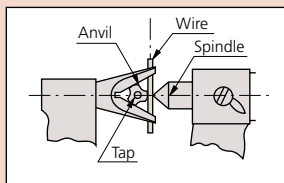

SPECIFICATIONS

Metric Digital model for 3 flutes cutting head

Range	Resolution	Order No.	Accuracy	Remarks	Setting Standard	Mass (g)
1 - 15mm	0.001mm	314-251-10	±4µm	w/Groove	ø5mm	275
		314-261-10	±4µm	—	ø5mm	275
10 - 25mm	0.001mm	314-252-10	±4µm	w/Groove	ø10mm	410
		314-262-10	±4µm	—	ø10mm	410
25 - 40mm	0.001mm	314-253-10	±5µm	—	ø25mm	465

Inch/Metric Digital model for 3 flutes cutting head

Range	Resolution	Order No.	Accuracy	Remarks	Setting Standard	Mass (g)
.05 - .6" / 1.27 - 15.24mm	.00005" / 0.001mm	314-351-10	±.0002"	w/Groove	ø.2"	275
		314-361-10	±.0002"	—	ø.2"	275
.4" - 1" / 10.16 - 25.4mm	.00005" / 0.001mm	314-352-10	±.0002"	w/Groove	ø.4"	410
		314-362-10	±.0002"	—	ø.4"	410
1" - 1.6" / 25.4 - 40.64mm	.00005" / 0.001mm	314-353-10	±.00025"	—	ø 1"	465

SPECIFICATIONS

Metric For 3 flutes cutting head

Range	Graduation	Order No.	Accuracy	Setting Standard	Remarks	Mass (g)
1 - 15mm	0.01mm	114-101	±4μm	ø5mm	w/Groove	120
		114-161	±4μm	ø5mm	—	120
10 - 25mm	0.01mm	114-102	±4μm	ø10mm	w/Groove	280
		114-162	±4μm	ø10mm	—	280
2.3 - 25mm	0.01mm	114-204*	±4μm	ø5mm	—	290
25 - 40mm	0.01mm	114-103	±5μm	ø25mm	—	400
40 - 55mm	0.01mm	114-104	±6μm	ø40mm	—	465
55 - 70mm	0.01mm	114-105	±6μm	ø55mm	—	675
70 - 85mm	0.01mm	114-106	±7μm	ø70mm	—	910

*Carbide-tipped anvil

Metric For 5 flutes cutting head

Range	Graduation	Order No.	Accuracy	Setting Standard	Remarks	Mass (g)
5 - 25mm	0.01mm	114-121	±4μm	ø5mm	w/Groove	255
		114-165	±4μm	ø5mm	—	255
2.3 - 25mm	0.01mm	114-137*	±4μm	ø5mm	—	220
25 - 45mm	0.01mm	114-122	±5μm	ø25mm	—	400
45 - 65mm	0.01mm	114-123	±6μm	ø55mm	—	540
65 - 85mm	0.01mm	114-124	±7μm	ø70mm	—	760

*Carbide-tipped anvil

Inch For 3 flutes cutting head

Range	Graduation	Order No.	Accuracy	Setting Standard	Mass (g)
.05 - .6"	.001"	114-163	±.0002"	ø.2"	120
.09 - 1"	.0001"	114-202*	±.0002"	ø.2"	280
1 - 1.6"	.001"	114-113	±.00025"	ø1"	400
1.6 - 2.2"	.001"	114-114	±.0003"	ø1.6"	465

*Carbide-tipped anvil and .0001" reading is obtained with vernier

Inch For 5 flutes cutting head

Range	Graduation	Order No.	Accuracy	Setting Standard	Mass (g)
.09 - 1"	.0001"	114-135	±.0002"	ø.2"	255

DIMENSIONS

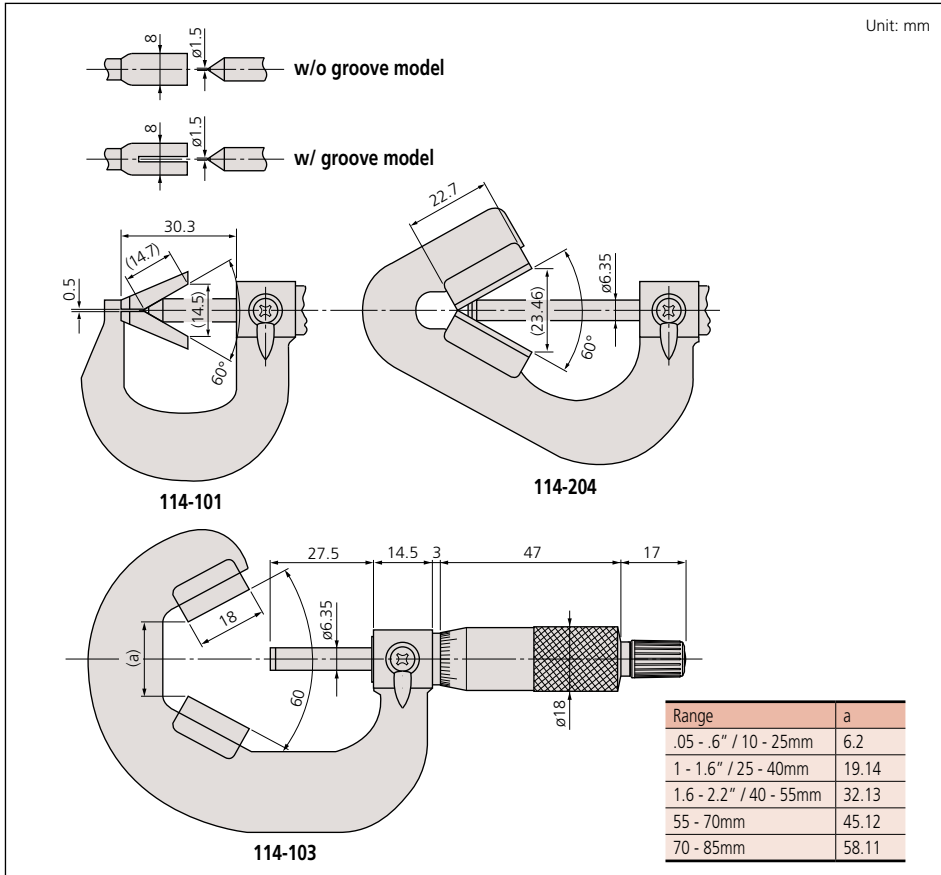

Limit Micrometers

SERIES 113

FEATURES

- Can be used as a GO/±NG gage by setting the upper and lower limits.
- Provided with a standard bar for 25mm - 50mm model.
- Supplied in fitted plastic case.



Technical Data

Graduation: 0.01mm
 Flatness: 0.6μm
 Parallelism: (3+R/100)μm, R=max. range (mm)
 Measuring faces: Carbide tipped



SPECIFICATIONS

Metric

Range	Graduation	Order No.	Accuracy
0 - 25mm	0.01mm	113-102	±3μm
25 - 50mm	0.01mm	113-103	±3μm

DIMENSIONS AND MASS

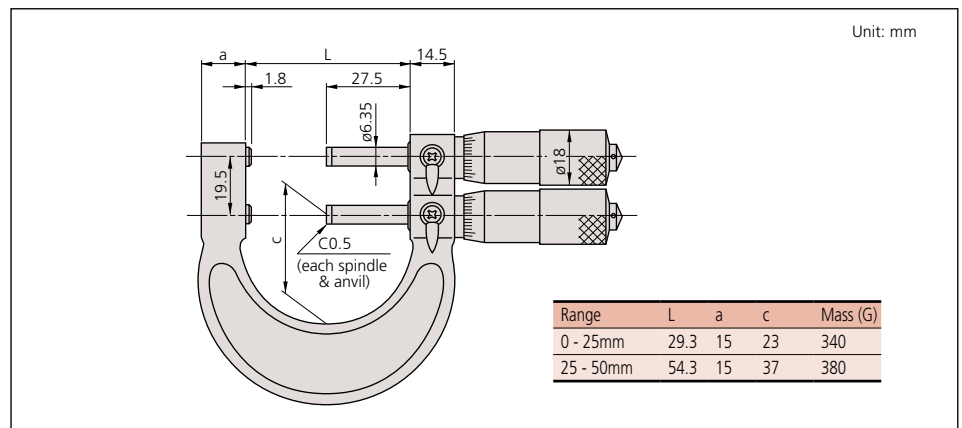

Pana Micrometers

SERIES 116 — Interchangeable Anvil Type

FEATURES

- Non-rotating spindle with optional seven interchangeable anvils (flat, spline, spherical, point, knife-edge, disk, and blade) for a wide range of applications.
- Interchangeable anvils (pair) are optional.
- With a standard bar except 0-1" and 0 - 25 mm model.
- V-anvils and conical spindle tips (matching pair) for screw thread measurement are also available.
- With Ratchet Stop for constant force.



116-101

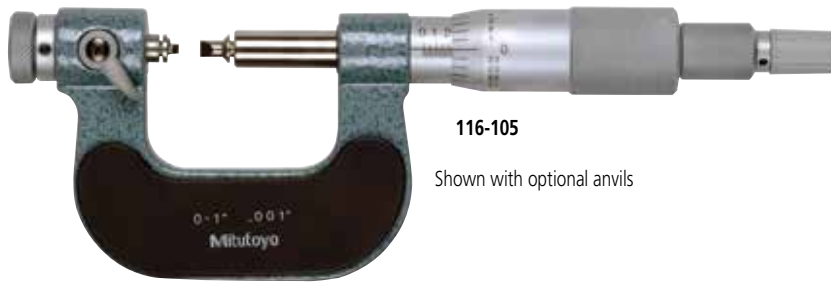

116-105

Shown with optional anvils

SPECIFICATIONS

Metric

Range	Graduation	Order No.	Accuracy
0 - 25mm	0.01mm	116-101	±4μm
25 - 50mm	0.01mm	116-102	±4μm

Inch

Range	Graduation	Order No.	Accuracy
0 - 1"	.001"	116-105	±.0002"
1" - 2"	.001"	116-106	±.0002"

Technical Data

Graduation: .001" or 0.01mm
Spindle feed error: .00012" / 3μm

Optional Accessories

Interchangeable V-anvil and conical spindle tip set:
For Metric/Unified screw

Order No.	Assortment of anvils and tips
116-830	0.4 - 0.5mm/64 - 48TPI (116-831) 0.6 - 0.9mm/44 - 28TPI (116-832) 1 - 1.75mm/24 - 14TPI (116-833) 2 - 3mm/13 - 9TPI (116-834) 3.5 - 5mm/8 - 5TPI (116-835) 5.5 - 7mm/4.5 - 3.5TPI (116-836)

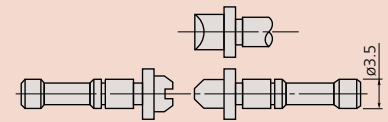

116-830

Interchangeable anvils set

Order No.	Assortment of anvils
116-800	Flat anvils (116-801) Spline anvils (116-802) Spherical anvils (116-803) Point anvils (116-804) Knife-edge anvils (116-805) Disk anvils (116-806) Blade anvils (116-807)

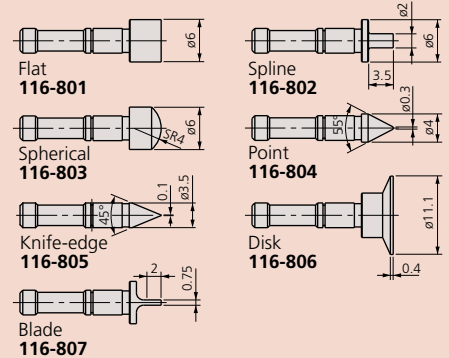

Spherical Face Micrometers

SERIES 395, 295, 115

Technical Data

Accuracy: Refer to the list of specifications.
 Flatness: .000024" / 0.6µm
 Display*: LCD
 Battery*: SR44 (1 pc.), **938882**
 Battery life*: Approx. 1.2 years under normal use
 Dust/Water protection level*: IP65
 *Digital models **Analog models

Function of Digital Model

Origin-set, Zero / ABS, Data hold, Data output, inch/mm conversion (on inch/metric models only)
 Alarm: Low voltage, Counting value composition error

Optional Accessories for Digital Model

05CZA662: SPC cable with data switch (40" / 1m)
05CZA663: SPC cable with data switch (80" / 2m)

Spherical anvil-spindle type

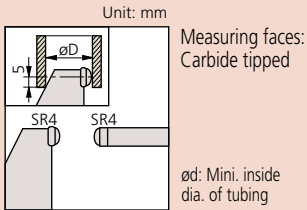

FEATURES

- IP65 water/dust protection (Series 395).
- Designed to measure the wall thickness of various tubing.
- With Ratchet Stop for constant force.
- With SPC output (Series 395).
- With digit counter (Series 295).
- With a standard bar except 0 -1" and 0 - 25mm model.
- Supplied in fitted plastic case.



115-153



395-371

SPECIFICATIONS

Metric — Digital model with spherical anvil					
Range	Resolution	Order No.	Accuracy	Remarks	Mass (g)
0 - 25mm	0.001mm	395-251 ^{S-F}	±2µm	D: 15mm	270
		395-271 ^{S-S}	±2µm	D: 15mm	270
25 - 50mm	0.001mm	395-252 ^{S-F}	±2µm	D: 15mm	330
		395-272 ^{S-S}	±2µm	D: 15mm	330
50 - 75mm	0.001mm	395-253 ^{S-F}	±2µm	D: 19mm	470
		395-273 ^{S-S}	±2µm	D: 19mm	470
75 - 100mm	0.001mm	395-254 ^{S-F}	±3µm	D: 20mm	625
		395-274 ^{S-S}	±3µm	D: 20mm	625

S-F: Spherical anvil and flat spindle
 S-S: Spherical anvil and spherical spindle

Metric — Mechanical counter model with spherical anvil					
Range	Graduation	Order No.	Accuracy	Remarks	Mass (g)
0 - 25mm	0.01mm	295-115 ^{S-F}	±3µm	D: 10mm	220
		295-215 ^{S-S}	±3µm	D: 10mm	220

S-F: Spherical anvil and flat spindle
 S-S: Spherical anvil and spherical spindle

Metric — With spherical anvil					
Range	Graduation	Order No.	Accuracy	Remarks	Mass (g)
0 - 25mm	0.01mm	115-115 ^{S-F}	±3µm	D: 10mm	180
		115-215 ^{S-S}	±3µm	D: 10mm	180
25 - 50mm	0.01mm	115-116 ^{S-F}	±3µm	D: 11mm	240
		115-216 ^{S-S}	±3µm	D: 11mm	240
50 - 75mm	0.01mm	115-117 ^{S-F}	±3µm	D: 17mm	315
		115-217 ^{S-S}	±3µm	D: 17mm	315
75 - 100mm	0.01mm	115-118 ^{S-F}	±4µm	D: 18mm	375
		115-218 ^{S-S}	±4µm	D: 18mm	375

S-F: Spherical anvil and flat spindle
 S-S: Spherical anvil and spherical spindle

Inch/Metric — Digital model with spherical anvil					
Range	Resolution	Order No.	Accuracy	Remarks	Mass (g)
0 - 1" / 0 - 25.4mm	.00005" / 0.001mm	395-351 ^{S-F}	±.0001"	D: .59"	270
		395-371 ^{S-S}	±.0001"	D: .59"	270
1" - 2" / 25.4 - 50.8mm	.00005" / 0.001mm	395-352 ^{S-F}	±.0001"	D: .59"	330
		395-372 ^{S-S}	±.0001"	D: .59"	330
2" - 3" / 50.8 - 76.2mm	.00005" / 0.001mm	395-353 ^{S-F}	±.0001"	D: .75"	470
		395-373 ^{S-S}	±.0001"	D: .75"	470
3" - 4" / 76.2 - 101.6mm	.00005" / 0.001mm	395-354 ^{S-F}	±.00015"	D: .79"	625
		395-374 ^{S-S}	±.00015"	D: .79"	625

S-F: Spherical anvil and flat spindle
 S-S: Spherical anvil and spherical spindle

Inch — Mechanical counter model with spherical anvil					
Range	Graduation	Order No.	Accuracy	Remarks	Mass (g)
0 - 1"	.0001"	295-153 ^{S-F*}	±.00015"	D: .40"	220
		295-253 ^{S-S*}	±.00015"	D: .40"	220

S-F: Spherical anvil and flat spindle
 S-S: Spherical anvil and spherical spindle
 *.0001" reading is obtained with vernier.

Inch — With spherical anvil					
Range	Graduation	Order No.	Accuracy	Remarks	Mass (g)
0 - 1"	.0001"	115-153 ^{S-F*}	±.00015"	D: .40"	180
		115-253 ^{S-S*}	±.00015"	D: .40"	180
1 - 2"	.001"	115-242 ^{S-S}	±.00015"	D: .44"	240
2 - 3"	.001"	115-243 ^{S-S}	±.00015"	D: .67"	315

S-F: Spherical anvil and flat spindle
 S-S: Spherical anvil and spherical spindle
 *.0001" reading is obtained with vernier.

Tube Micrometers

SERIES 395, 295, 115— Spherical and Cylindrical Anvils



FEATURES

- IP65 water/dust protection (Series 395).
- Designed to measure the wall thickness of various tubing.
- The Tube Micrometers have two combinations of measuring faces (carbide-tipped): spherical-flat type.
- With Ratchet Stop for constant force.
- With SPC output (Series 395).
- With digit counter (Series 295).
- With a standard bar except 0 -1" and 0 - 25mm model.
- Supplied in fitted plastic case.

Technical Data

Accuracy: Refer to the list of specifications.
 Flatness: .000024" / 0.6µm
 Display*: LCD
 Battery*: SR44 (1 pc.), **938882**
 Battery life*: Approx. 1.2 years under normal use
 Dust/Water protection level*: IP65
 *Digital models

Function of Digital Model

Origin-set, Zero / ABS, Data hold, Data output, inch/mm conversion (on inch/metric models only)
 Alarm: Low voltage, Counting value composition error

Optional Accessories for Digital Model

05CZA662: SPC cable with data switch (40" / 1m)
05CZA663: SPC cable with data switch (80" / 2m)

Pin Anvil Type



395-261



Type A

Type B



Type C

Type D

SPECIFICATIONS

Metric — Digital model with cylindrical anvil					
Range	Resolution	Order No.	Accuracy	Remarks	Mass (g)
0 - 25mm	0.001mm	395-261	±3µm	Type A	270
		395-262	±3µm	Type B	270
		395-263	±3µm	Type C	310
		395-264	±3µm	Type D	310

Inch/Metric — Digital model with cylindrical anvil					
Range	Resolution	Order No.	Accuracy	Remarks	Mass (g)
0 - 1" / 0 - 25.4mm	.00005" / 0.001mm	395-362	±.00015"	Type B	270
		395-363	±.00015"	Type C	310
		395-364	±.00015"	Type D	310

Metric — Mechanical counter model					
Range	Graduation	Order No.	Accuracy	Remarks	Mass (g)
0 - 25mm	0.01mm	295-302	±3µm	Type A	210

Inch — Mechanical counter model					
Range	Graduation	Order No.	Accuracy	Remarks	Mass (g)
0 - 1"	.0001"	295-313	±.00015"	Type C	210
		295-314	±.00015"	Type D	210

Metric — With cylindrical anvil					
Range	Graduation	Order No.	Accuracy	Remarks	Mass (g)
0 - 25mm	0.01mm	115-302	±3µm	Type A	180
		115-308	±3µm	Type B	180
		115-315	±3µm	Type C	180
		115-316	±3µm	Type D	180
25 - 50mm	0.01mm	115-303	±3µm	Type A	240
		115-309	±3µm	Type B	240

Inch — With cylindrical anvil					
Range	Graduation	Order No.	Accuracy	Remarks	Mass (g)
0 - 1"	.001"	115-305	±.00015"	Type A	180
	.0001"	115-313*	±.00015"	Type C	180
	.0001"	115-314*	±.00015"	Type D	180

*.0001" reading is obtained with vernier.

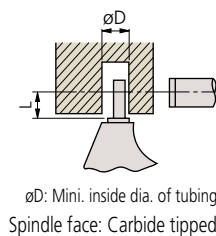
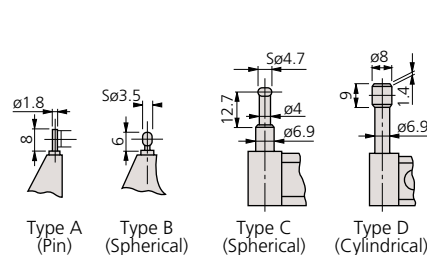

Anvil	D	L
Type A	2	4
Type B	3.6	4
Type C	4.8	12
Type D	8.2	22



Technical Data

Accuracy: Refer to the list of specifications.
 Resolution*: .0005"/0.001mm or 0.001mm
 Graduation**: .0001" or 0.01mm
 Spindle face: Carbide tipped
 Display*: LCD
 Battery*: SR44 (1 pc.), **938882**
 Battery life*: Approx. 1.2 years under normal use
 Dust/Water protection level*: IP65
 *Digital models **Analog models

Function of Digital Model

Origin-set, Zero / ABS, Data hold, Data output,
 inch/mm conversion (on inch/metric models only)
 Alarm: Low voltage, Counting value composition error

Optional Accessories

- 05CZA662:** SPC cable with data switch (40" / 1m)*
- 05CZA663:** SPC cable with data switch (80" / 2m)*
- 201218:** V-anvil
- 950758:** Disc. anvil for 1" / 25m models
- 950759:** Disc. anvil for 2" / 50m models

*Only for digital models

Applications



Using flat anvil (201216)



With the disc. anvil (950758) Shown above, the Uni-Mike is used as a height micrometer

"Uni-Mike"

SERIES 317, 117 — Interchangeable Anvil Type

FEATURES

- IP65 water/dust protection (Series 317).
- Measures tubing thickness, shoulder-edge distance, rivet head height, etc. with interchangeable anvils (flat anvil, rod anvil, V-anvil).
- Supplied with Flat Anvil (**201216**) and Rod Anvil: .118"/ø3mm dia. rod anvil (**201217**) for 0-1"/0-25mm models, .197"/ø5mm (**201379**) for 1-2" / 25-50mm model.
- With special Disk Anvils. The Uni-Mike is used as a height micrometer. The disks have a lapped, mirror surface.
- With a standard bar except 0 -1" and 0-25mm model.
- Supplied in fitted plastic case.



317-351



117-107

SPECIFICATIONS

Metric Digital model with ratchet stop

Range	Resolution	Order No.	Accuracy	Mass (g)
0 - 25mm	0.001mm	317-251	±4µm	335
25 - 50mm	0.001mm	317-252	±4µm	360

Excluding quantizing error

Inch/Metric Digital model with friction thimble

Range	Resolution	Order No.	Accuracy	Mass (g)
0 - 1" / 0 - 25.4mm	.00005" / 0.001mm	317-351	±.0002"	340
1 - 2" / 25.4 - 50.8mm	.00005" / 0.001mm	317-352	±.0002"	365

Excluding quantizing error

Metric With ratchet stop

Range	Graduation	Order No.	Accuracy	Mass (g)
0 - 25mm	0.01mm	117-101	±4µm	255
25 - 50mm	0.01mm	117-102	±4µm	320

Inch With friction thimble

Range	Graduation	Order No.	Accuracy	Mass (g)
0 - 1"	.0001"	117-107*	±.0002"	255
1 - 2"	.0001"	117-108*	±.0002"	320

*.0001" reading is obtained with vernier

DIMENSIONS

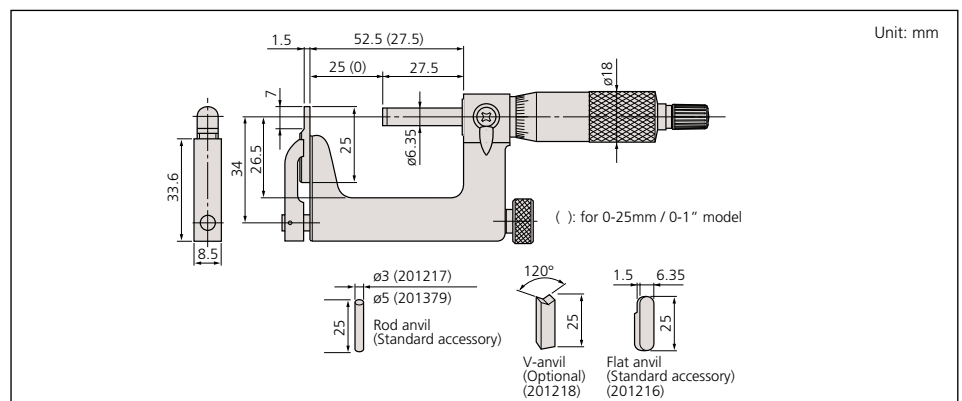

Sheet Metal Micrometers

SERIES 389, 119, 118



FEATURES

- Measures thickness of sheet metal, paper, plastic, and rubber parts.
- With Ratchet Stop for constant force.
- With a standard bar except for 0 - 1" / 0 - 25mm model.
- IP65 water/dust protection (Series 389*).
- *Except for **389-514** / **389-714**.
- Supplied in fitted plastic case.

Technical Data

Accuracy: Refer to the list of specifications.
 Resolution*: .00005" / 0.001mm or 0.001mm
 Graduation**: 0.01mm, .001" or .0001"
 Flatness: .000024" / 0.6µm for models with 6" / 150mm throat
 .00004" / 1µm for models with 12" / 300mm throat
 Parallelism: .00012" / 3µm
 Measuring faces: Carbide tipped
 Display*: LCD
 Battery*: SR44 [1 pc. (2 pcs.: **389-514** and **389-714**)], **938882**
 Battery life*: Approx. 1.2 years under normal use (1.8 years: **389-514** and **389-714**)
 Dust/Water protection level*: IP65
 *Digital models **Analog models

Function of Digital Model

Origin-set, Zero-setting, Data hold, Data output, inch/mm conversion (on inch/metric models only)
 Alarm: Low voltage, Counting value composition error

Optional Accessories for Digital Model

- 05CZA662**: SPC cable with data switch (40" / 1m)
- 05CZA663**: SPC cable with data switch (80" / 2m)
- 937387**: SPC cable for **389-514/389-714** (40" / 1m)
- 965013**: SPC cable for **389-514/389-714** (80" / 2m)



DIMENSIONS

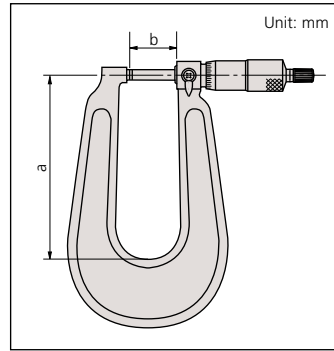

SPECIFICATIONS

Metric		Digital model			
Range	Resolution	Order No.	Accuracy	a/b	
0 - 25mm	0.001mm	389-251	±4µm	160/27.5mm	
0 - 25mm	0.001mm	389-261^{S-F}	±4µm	160/27.5mm	
0 - 25mm	0.001mm	389-271^{S-S}	±4µm	160/27.5mm	
0 - 25mm	0.001mm	389-514	±5µm	330/35mm	
25 - 50mm	0.001mm	389-252	±4µm	165/27.5mm	
25 - 50mm	0.001mm	389-262^{S-F}	±4µm	165/27.5mm	
25 - 50mm	0.001mm	389-272^{S-S}	±4µm	165/27.5mm	

S-F: Spherical anvil and flat spindle
 S-S: Spherical anvil and spherical spindle

Inch/Metric		Digital model			
Range	Resolution	Order No.	Accuracy	a/b	
0 - 1" / 0 - 25.4mm	.00005" / 0.001mm	389-351	±.0002"	6.3"/1.08"	
		389-361^{S-F}	±.0002"	6.3"/1.08"	
		389-371^{S-S}	±.0002"	6.3"/1.08"	
		389-714	±.00025"	13"/1.38"	
1 - 2" / 25.4 - 50.8mm	.00005" / 0.001mm	389-352	±.0002"	6.5"/1.08"	
		389-362^{S-F}	±.0002"	6.5"/1.08"	
		389-372^{S-S}	±.0002"	6.5"/1.08"	

S-F: Spherical anvil and flat spindle
 S-S: Spherical anvil and spherical spindle

Metric		Dial reading model			
Range	Graduation	Order No.	Accuracy	a/b	
0 - 25mm	0.01mm	118-101	±4µm	110/27.5mm	
0 - 25mm	0.01mm	118-102	±4µm	160/27.5mm	
0 - 25mm	0.01mm	118-114^{S-F}	±4µm	160/27.5mm	
0 - 25mm	0.01mm	118-118^{S-S}	±4µm	160/27.5mm	
0 - 25mm	0.01mm	118-103	±5µm	330/35mm	
25 - 50mm	0.01mm	118-110	±4µm	165/27.5mm	

S-F: Spherical anvil and flat spindle
 S-S: Spherical anvil and spherical spindle

Inch		Dial reading model			
Range	Graduation	Order No.	Accuracy	a/b	
0 - 1"	.0001"	118-129	±.0002"	6.3"/1.08"	
		118-116^{S-F}	±.0002"	6.3"/1.08"	
		118-120^{S-S}	±.0002"	6.3"/1.08"	
1" - 2"	.001"	118-107	±.00025"	13"/1.38"	
		118-112	±.0002"	6.5"/1.08"	

S-F: Spherical anvil and flat spindle
 S-S: Spherical anvil and spherical spindle
 *.0001" reading is obtained with vernier.

Metric		Dial reading model			
Range	Graduation	Order No.	Accuracy	Throat	
0 - 25mm	0.01mm	119-202^{S-F}	±4µm	50mm	

S-F: Spherical anvil and flat spindle



DIMENSIONS AND MASS

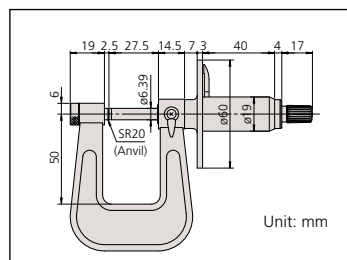

Anvil-Spindle Combinations



Standard, Flat-Flat



Spherical-Flat (S-F)



Spherical-Spherical (S-S)

The Series 119 is provided with a dial for making easy and quick reading.



Technical Data

Accuracy: Refer to the list of specifications.
 Resolution*: .00005"/0.001mm or 0.001mm
 Graduation**: .0001" or 0.01mm
 Parallelism: .00012" / 3µm for models up to 3" / 75mm
 (3+R/100)µm for models over 75mm,
 R=max. range (mm) .00016" for 4" models
 Display*: LCD
 Battery*: SR44 (1 pc.), 938882
 Battery life*: Approx. 1.2 years under normal use
 *Digital models **Analog models

Function of Digital Model

Origin-set, Zero / ABS, Data hold, Data output,
 inch/mm conversion (on inch/metric models only)
 Alarm: Low voltage, Counting value composition error

Optional Accessories for Digital Model

05CZA662: SPC cable with data switch (1m / 40")
05CZA663: SPC cable with data switch (2m / 80")
937387: SPC cable for Quickmike type (1m / 40")
965013: SPC cable for Quickmike type (2m / 80")

TYPE AND DIMENSIONS

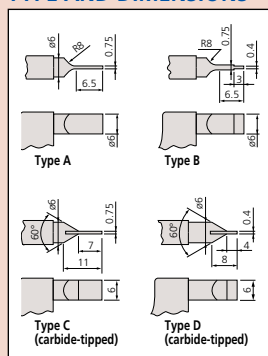

Blade Micrometers

SERIES 422,122 — Non-Rotating Spindle Type

FEATURES

- The anvil and the spindle have a blade for measuring the groove diameter of shafts, keyways, and other hard-to-reach areas.
- With Ratchet Stop for constant force.
- Speedy spindle feed of .4"/10mm /rev. (Quickmike type).
- With a standard bar except 0 - 1" and 0 -25mm model.
- Supplied in fitted plastic case.

Quickmike type



422-421



422-330



122-125



ABSOLUTE
Master System Powered by MITUTOYO

SPECIFICATIONS

Metric		Digital model			
Range	Resolution	Order No.	Accuracy	Remarks	Mass (g)
0 - 25mm	0.001mm	422-230	±3µm	Type A	365
		422-260	±3µm	Type B	365
		422-270	±3µm	Type C	365
		422-271	±3µm	Type D	365
25 - 50mm	0.001mm	422-231	±3µm	Type A	565
		422-261	±3µm	Type B	565
50 - 75mm	0.001mm	422-232	±3µm	Type A	465
75 - 100mm	0.001mm	422-233	±4µm	Type A	580

Metric		Quickmike type			
Range	Resolution	Order No.	Accuracy	Mass (g)	
0 - 30mm	0.001mm	422-411	±3µm	350	
25 - 55mm	0.001mm	422-412	±3µm	490	

Metric						
Range	Graduation	Order No.	Accuracy	Remarks	Mass (g)	
0 - 25mm	0.01mm	122-101	±3µm	Type A	260	
		122-111	±3µm	Type B	260	
		122-161	±3µm	Type C	275	
		122-141	±3µm	Type D	275	
25 - 50mm	0.01mm	122-102	±3µm	Type A	300	
		122-112	±3µm	Type B	300	
		122-162	±3µm	Type C	315	
50 - 75mm	0.01mm	122-142	±3µm	Type D	315	
75 - 100mm	0.01mm	122-103	±3µm	Type A	360	
100 - 125mm	0.01mm	122-104	±4µm	Type A	525	
125 - 150mm	0.01mm	122-105	±4µm	Type A	670	
150 - 175mm	0.01mm	122-106	±4µm	Type A	775	
175 - 200mm	0.01mm	122-107	±5µm	Type A	950	
		122-108	±5µm	Type A	1140	

Inch/Metric		Digital model			
Range	Resolution	Order No.	Accuracy	Remarks	Mass (g)
0 - 1" / 0 - 25.4mm	.00005" / 0.001mm	422-330	±.00015"	Type A	365
		422-360	±.00015"	Type B	365
		422-370	±.00015"	Type C	365
		422-371	±.00015"	Type D	365
1 - 2" / 25.4 - 50.8mm	.00005" / 0.001mm	422-331	±.00015"	Type A	565
		422-361	±.00015"	Type B	565
2 - 3" / 50.8 - 76.2mm	.00005" / 0.001mm	422-332	±.00015"	Type A	465
3 - 4" / 76.2 - 101.6mm	.00005" / 0.001mm	422-333	±.0002"	Type A	580

Inch/Metric		Quickmike type			
Range	Resolution	Order No.	Accuracy	Remarks	Mass (g)
0 - 1.2" / 0 - 30.48mm	.00005" / 0.001mm	422-421	±.00015"	Type A	350
				Type A	490
1 - 2.2" / 25.4 - 55.88mm	.00005" / 0.001mm	422-422	±.00015"	Type A	490

Inch						
Range	Graduation	Order No.	Accuracy	Remarks	Mass (g)	
0 - 1"	.0001"	122-125	±.00015"	Type A	260	
		122-135	±.00015"	Type B	260	
		122-151	±.00015"	Type D	275	
1 - 2"	.0001"	122-126	±.00015"	Type A	300	
2 - 3"	.0001"	122-127	±.00015"	Type A	360	
3 - 4"	.0001"	122-128	±.0002"	Type A	525	

Disk Micrometers

SERIES 323, 223, 123 - Rotating Spindle

FEATURES

- Diameter of measuring disk: .787"/ 20mm
- .028"/ 0.7mm (1mm: models over 100mm) edge thickness to enter narrow recesses.
- With Ratchet Stop for constant force.
- With a standard bar except for 0 - 1"/ 0 - 25mm model.
- With SPC output (Series 323).
- The Series 223 is provided with a mechanical digit counter for quick reading of measurements.
- Supplied in fitted plastic case. (Over 100mm models supplied wooden cases)



123-125



323-350



123-103



223-125

SPECIFICATIONS

Metric Digital model

Range	Resolution	Order No.	Accuracy	Mass (g)
0 - 25mm	0.001mm	323-250	±4μm	290
25 - 50mm	0.001mm	323-251	±4μm	355
50 - 75mm	0.001mm	323-252	±6μm	555
75 - 100mm	0.001mm	323-253	±6μm	610

Metric Mechanical counter model

Range	Graduation	Order No.	Accuracy	Mass (g)
0 - 25mm	0.01mm	223-101	±4μm	260
25 - 50mm	0.01mm	223-102	±4μm	290

Metric

Range	Graduation	Order No.	Accuracy	Mass (g)
0 - 25mm	0.01mm	123-101	±4μm	200
		123-113*	±4μm	230
25 - 50mm	0.01mm	123-102	±4μm	250
		123-114*	±4μm	270
50 - 75mm	0.01mm	123-103	±6μm	300
		123-115*	±6μm	320
75 - 100mm	0.01mm	123-104	±6μm	375
		123-116*	±6μm	390
100 - 125mm	0.01mm	123-105	±7μm	520
125 - 150mm	0.01mm	123-106	±7μm	570
150 - 175mm	0.01mm	123-107	±8μm	730
175 - 200mm	0.01mm	123-108	±8μm	890
200 - 225mm	0.01mm	123-109	±8μm	1000
225 - 250mm	0.01mm	123-110	±9μm	1200
250 - 275mm	0.01mm	123-111	±9μm	1410
275 - 300mm	0.01mm	123-112	±9μm	1680

*The measuring disks have carbide tips.
Note: The disk diameter of models over 100mm is 30mm.

Inch/Metric Digital model

Range	Resolution	Order No.	Accuracy	Mass (g)
0 - 1"/0 - 25.4mm	.00005"/ 0.001mm	323-350	±.0002"	290
1 - 2"/25.4 - 50.8mm	.00005"/0.001mm	323-351	±.0002"	355
2 - 3"/50 - 76.2mm	.00005"/0.001mm	323-352	±.0003"	555
3 - 4"/76.2 - 101.6mm	.00005"/0.001mm	323-353	±.0003"	610

Inch Mechanical counter model

Range	Graduation	Order No.	Accuracy	Mass (g)
0 - 1"	.001"	223-125	±.0002"	260

Inch

Range	Graduation	Order No.	Accuracy	Mass (g)
0 - 1"	.001"	123-125	±.0002"	200
1 - 2"	.001"	123-126	±.0002"	250
2 - 3"	.001"	123-127	±.0003"	300
3 - 4"	.001"	123-128	±.0003"	375

Root tangent length of gear (En)

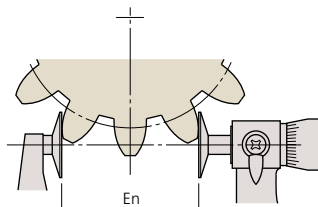

Note: Root tangent length measurement is not available for some types of gears.



Technical Data

Accuracy: Refer to the list of specifications.
Resolution*: .00005"/0.001mm or 0.001mm
Graduation**:.001" or 0.01mm
Flatness: .00004"/ 1μm for models up to 4"/100mm
.000063"/ 1.6μm for models over 4"/ 100mm
Parallelism: .00016"/ 4μm for models up to 2"/ 50mm
.00024" for models up to 4"
(4+R/50)μm for models up to 100mm
(5+R/75)μm for models over 100mm, R=max. range (mm)
Measurable module: 0.5-6 (0.7-11: models over 100mm)
Display*: LCD
Battery*: SR44 (1 pc.), **938882**
Battery life*: Approx. 1.2 years under normal use
*Digital models **Analog models

Function of Digital Model

Origin-set, Zero / ABS, Data hold, Data output, inch/mm conversion (on inch/metric models only)
Alarm: Low voltage, Counting value composition error

Optional Accessories for Digital Model

- 05CZA662:** SPC cable with data switch (40" / 1m)
- 05CZA663:** SPC cable with data switch (80" / 2m)

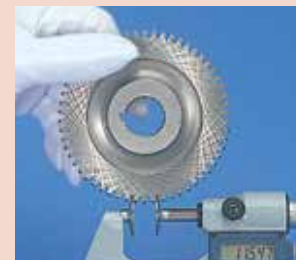

DIMENSIONS

Unit: mm

Digital models up to 75mm

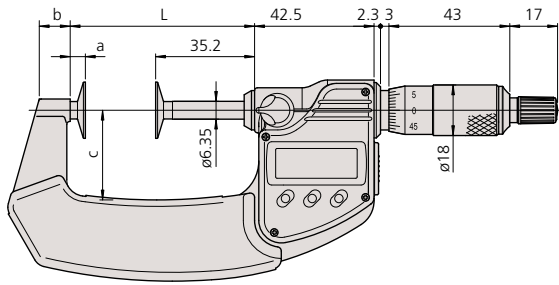

Analog models up to 50mm

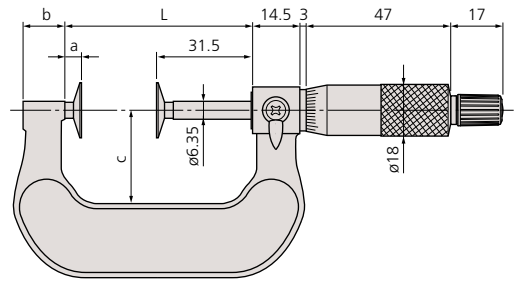

Digital models up to 75mm

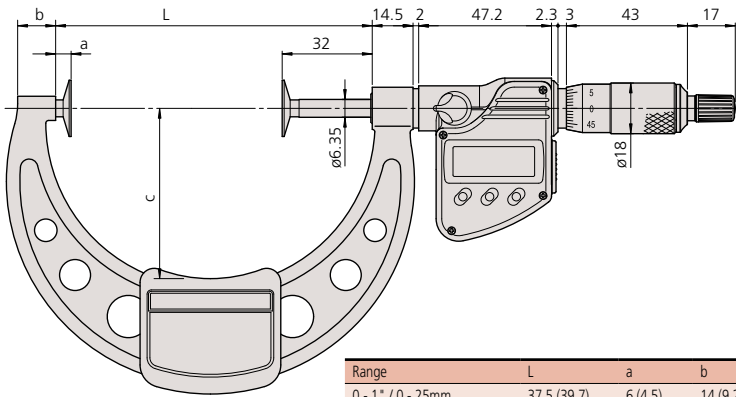

Analog over 50mm

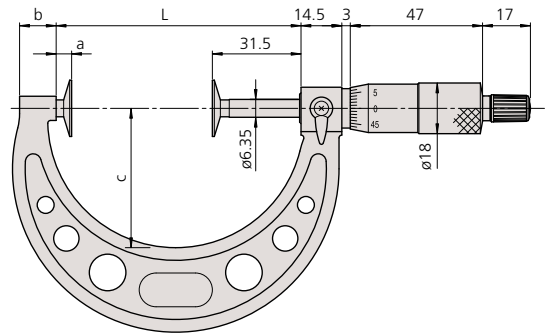

Range	L	a	b	c	ϕd	ϕe	t
0 - 1" / 0 - 25mm	37.5 (39.7)	6 (4.5)	14 (9.2)	25 (25.4)	20	8 (9.8)	0.7
1 - 2" / 25 - 50mm	62.5 (65.6)	6 (5.4)	14 (11)	32 (31.9)	20	8 (9.8)	0.7
2 - 3" / 50 - 75mm	87 (90.7)	5.5 (5.5)	11 (12.2)	49 (50)	20	8 (9.8)	0.7
3 - 4" / 75 - 100mm	112 (112.5)	5.5 (5.5)	11 (13.5)	63 (60.5)	20	8 (9.8)	0.7
4 - 5" / 100 - 125mm	137.5	6	12	79	30	12	1
5 - 6" / 125 - 150mm	162.5	6	15	94	30	12	1
6 - 7" / 150 - 175mm	187.5	6	16	106	30	12	1
7 - 8" / 175 - 200mm	212.5	6	15	118	30	12	1
8 - 9" / 200 - 225mm	237.5	6	14	130	30	12	1
9 - 10" / 225 - 250mm	262.5	6	14	143	30	12	1
10 - 11" / 250 - 275mm	287.5	6	15	156	30	12	1
11 - 12" / 275 - 300mm	312.5	6	15	169	30	12	1

Data in () applies to those with carbide tipped disks.

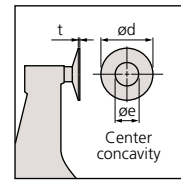

Technical Data

Graduation: .001" or 0.01mm
 Flatness: .00004" / 1 μ m
 Parallelism: .00012" / 3 μ m
 Measuring Force: 8.02 \pm 0.8N
 53.9KPa \pm 4.9 KPa



Unit: mm

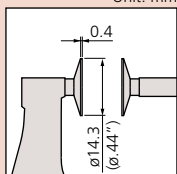

(): Inch model

Paper Thickness Micrometers

SERIES 169 — Non-Rotating Spindle Type Designed for Paper Thickness Measurement

FEATURES

- Non-rotating spindle.
- With Ratchet Stop for constant force.
- Supplied in fitted plastic case.



169-101

SPECIFICATIONS

Metric				
Range	Graduation	Order No.	Accuracy	Mass (g)
0 - 25mm	0.01mm	169-101	$\pm 4\mu$ m	230g

DIMENSIONS

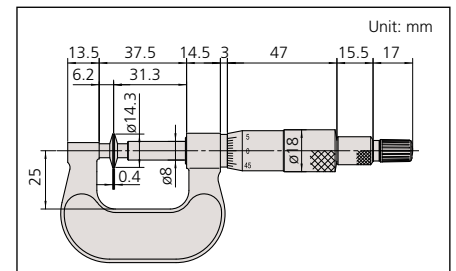

Inch				
Range	Graduation	Order No.	Accuracy	Mass (g)
0 - 1"	.001"	169-103	$\pm .0002"$	230g

Disk Micrometers

SERIES 369, 227, 169 — Non-Rotating Spindle Type



FEATURES

- The Disk Micrometer is designed to easily measure root tangent length of spur gears and helical gears.
- Non-rotating spindle eliminates torque on workpiece.
- With standard bar except 0 - 15mm, 0 - .6" 0 - 25mm, 0 - 1", 0 - 30mm & 0 - 1.2" model
- Speedy spindle feed of 10mm/rev. (Quickmike type).
- Diameter of measuring disk: .787" / 20mm
- With Ratchet Stop for constant force.
- With SPC output (Series 369).
- Supplied in fitted plastic case



369-350



Quickmike type

369-421

Quickmike type with adjustable measuring force



227-221



169-201



SPECIFICATIONS

Metric		Digital model	
Range	Resolution	Order No.	Accuracy
0 - 25mm	0.001mm	369-250	±4µm
25 - 50mm	0.001mm	369-251	±4µm
50 - 75mm	0.001mm	369-252	±6µm
75 - 100mm	0.001mm	369-253	±6µm

Inch/Metric		Digital model	
Range	Resolution	Order No.	Accuracy
0 - 1" / 0 - 25.4mm	.00005" / 0.001mm	369-350	±.0002"
1 - 2" / 25.4 - 50.8mm	.00005" / 0.001mm	369-351	±.0002"
2 - 3" / 50.8 - 76.2mm	.00005" / 0.001mm	369-352	±.0003"
3 - 4" / 76.2 - 101.6mm	.00005" / 0.001mm	369-353	±.0003"

Metric		Quickmike type	
Range	Resolution	Order No.	Accuracy
0 - 30mm	0.001mm	369-411	±4µm
25 - 55mm	0.001mm	369-412	±4µm

Inch/Metric		Quickmike type	
Range	Resolution	Order No.	Accuracy
0 - 1.2" / 0 - 30.48mm	.00005" / 0.001mm	369-421	±.0002"
1 - 2.2" / 25.4 - 55.88mm	.00005" / 0.001mm	369-422	±.0002"

Metric		Quickmike type with adjustable measuring force		
Range	Resolution	Order No.	Accuracy	Measuring force
0 - 10mm	0.001mm	227-223	±4µm	2N - 10N
0 - 15mm	0.001mm	227-221	±4µm	0.5N - 2.5N

Metric			
Range	Graduation	Order No.	Accuracy
0 - 25mm	0.01mm	169-201	±4µm
25 - 50mm	0.01mm	169-202	±4µm
50 - 75mm	0.01mm	169-205	±6µm
75 - 100mm	0.01mm	169-207	±6µm

Inch			
Range	Graduation	Order No.	Accuracy
0 - 1"	.001"	169-203	±.0002"
1 - 2"	.001"	169-204	±.0002"
2 - 3"	.001"	169-206	±.0003"
3 - 4"	.001"	169-208	±.0003"

Technical Data

Accuracy: Refer to the list of specifications.
 Resolution*: .00005" / 0.001mm or 0.001mm
 Graduation***: .001" or 0.01mm
 Flatness: .00004" / 1µm
 Parallelism: 4µm / .00016" for models up to 2" / 50mm
 6µm / .00024" for models over 2" / 50mm
 Measurable module: 0.5-6
 Display*: LCD
 Battery*: SR44 (1 pc.), **938882**
 Battery life*: Approx. 1.2 years under normal use
 (1 year: Quickmike type, 3 years: Quickmike type with fine-loading)
 Series 227: Refer to page B-6 for more information.
 *Digital models **Analog models

Function of Digital Model

Origin-set, Zero / ABS, Data hold, Data output, inch/mm conversion (on inch/metric models only)
 Alarm: Low voltage, Counting value composition error

Optional Accessories for Digital Model

- 05CZA662**: SPC cable with data switch (40" / 1m)
- 05CZA663**: SPC cable with data switch (80" / 2m)
- 937387**: SPC cable for Quickmike type (40" / 1m)
- 965013**: SPC cable for Quickmike type (80" / 2m)

DIMENSIONS AND MASS

Unit: mm

Digital models up to 75mm

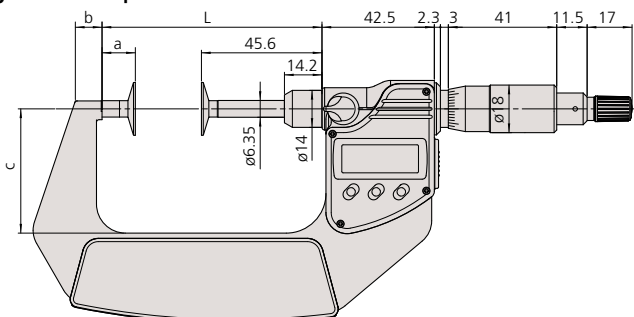

Adjustable measuring force type

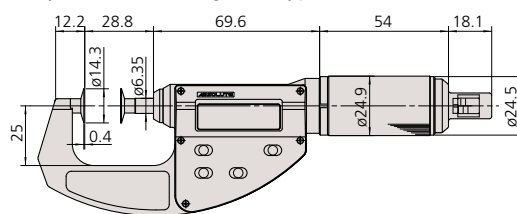

Digital models over 75mm

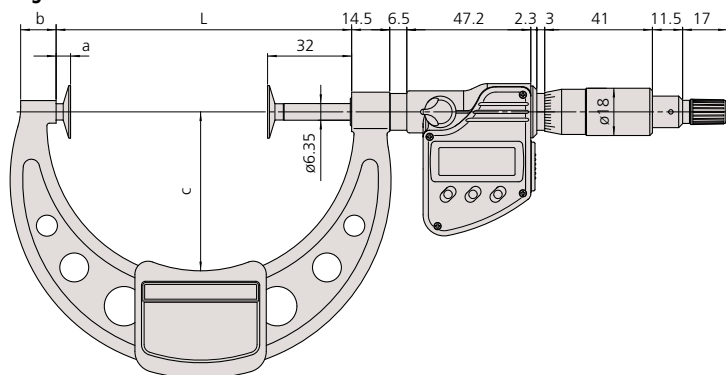

Analog models up to 50mm

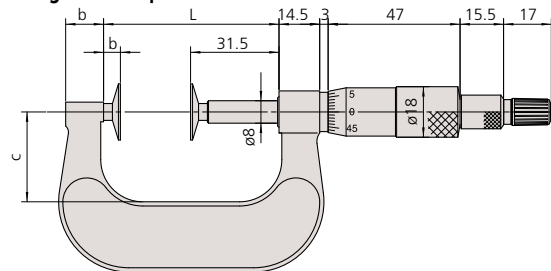

Quickmike type

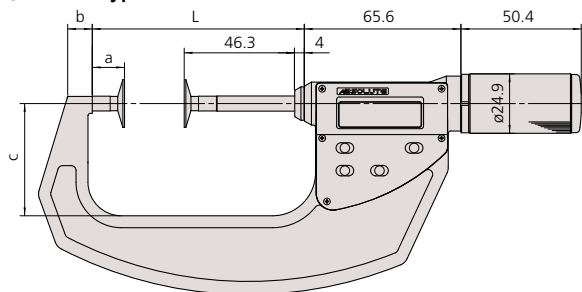

Analog models over 50mm

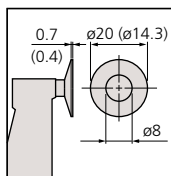
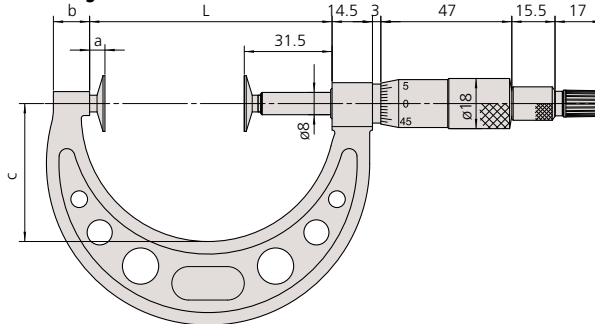

(): Adjustable measuring force type

Digital model

Range	L	a	b	c	Mass (g)
0 - 25mm / 0 - 1"	58.5	12.9	7	32	340
25 - 50mm / 1 - 2"	83.5	12.9	9.8	47	480
50 - 75mm / 2 - 3"	108.5	12.9	11.2	60	635
75 - 100mm / 3 - 4"	112.5	5.5	13.5	60.5	475
0 - 30mm* / 0 - 1.2"	63.8	13.5	8.5	36	360
25 - 55mm* / 1 - 2.2"	88.8	13.5	10.3	47	490

*Quickmike type

Analog model

Range	L	a	b	c	Mass (g)
0 - 25mm / 0 - 1"	37.5	6	13.5	25	230
25 - 50mm / 1 - 2"	62.5	6	13.5	32	280
50 - 75mm / 2 - 3"	87	5.5	13	49.5	315
75 - 100mm / 3 - 4"	112	5.5	13	63.5	400

Gear Tooth Micrometers

SERIES 324, 124 — Interchangeable Ball Anvil-Spindle Tip Type



FEATURES

- IP65 water/dust protection (Series 324).
- Measures over-pin diameter of gears with precision steel (carbide) ball-tipped measuring faces.
- With a standard bar except 0 - 25mm and 0 - 1" model
- Interchangeable ball anvil-spindle tips for various gear modules (0.5 - 5.25) are optional.
- With Ratchet Stop for constant force.
- With SPC output (Series 324).
- Supplied in fitted plastic case (Models over 150mm have wooden case).



324-351-10
Shown with optional ball anvils



124-173
Shown with optional ball anvils

SPECIFICATIONS

Metric		Digital model		
Range	Resolution	Order No.	Accuracy	Mass (g)
0 - 25mm	0.001mm	324-251-10	±4µm	400
25 - 50mm	0.001mm	324-252-10	±4µm	490
50 - 75mm	0.001mm	324-253-10	±4µm	530
75 - 100mm	0.001mm	324-254-10	±5µm	600

Inch/Metric		Digital model		
Range	Resolution	Order No.	Accuracy	Mass (g)
0 - 1" / 0 - 25mm	.00005"/0.001mm	324-351-10	±.0002"	400
1 - 2" / 25 - 50mm	.00005"/0.001mm	324-352-10	±.0002"	490
2 - 3" / 50 - 75mm	.00005"/0.001mm	324-353-10	±.0002"	530
3 - 4" / 75 - 100mm	.00005"/0.001mm	324-354-10	±.00025"	600

Metric				
Range	Graduation	Order No.	Accuracy	Mass (g)
0 - 25mm	0.01mm	124-173	±4µm	295
25 - 50mm	0.01mm	124-174	±4µm	400
50 - 75mm	0.01mm	124-175	±4µm	460
75 - 100mm	0.01mm	124-176	±5µm	540
100 - 125mm	0.01mm	124-177	±5µm	640
125 - 150mm	0.01mm	124-178	±5µm	760
150 - 175mm	0.01mm	124-179	±6µm	900
175 - 200mm	0.01mm	124-180	±6µm	1060
200 - 225mm	0.01mm	124-181	±6µm	1230
225 - 250mm	0.01mm	124-182	±7µm	1430
250 - 275mm	0.01mm	124-183	±7µm	1620
275 - 300mm	0.01mm	124-195	±7µm	2070

DIMENSIONS AND MASS

(): 275-300mm model

Range	L	a	Mass (g)
0 - 25mm	64.5	32	295
25 - 50mm	90	45	400
50 - 75mm	115.6	65	460
75 - 100mm	140.6	79	540
100 - 125mm	165.6	93	640
125 - 150mm	190.5	105	760
150 - 175mm	215.5	120	900
175 - 200mm	240.5	130	1060
200 - 225mm	265.5	147	1230
225 - 250mm	290.5	165	1430
250 - 275mm	315.5	171	1620
275 - 300mm	353	187	2070

Technical Data

Accuracy: Refer to the list of specifications.
 Resolution*: 0.001mm or .00005"/0.001mm
 Graduation**: 0.01mm
 Display*: LCD
 Battery*: SR44 (1 pc.) **938882**
 Battery life*: Approx. 1.2 years under normal use
 Dust/Water protection level*: IP65
 *Digital models **Analog models

Function of Digital Model

Zero / ABS, Data hold, Data output, Preset, inch/mm conversion (on inch/metric models only)
 Alarm: Low voltage, Counting value composition error
 Function Lock
 2 Presets

Optional Accessories

05CZA662: SPC cable with data switch (1m / 40")*
05CZA663: SPC cable with data switch (2m / 80")*
 *Only for digital models



Interchangeable ball anvil-spindle tip set:

Diameter of ball anvil	Order No.	Gear module	Diametral pitch
0.8mm	124-801*	0.5 - 0.55	50
1mm	124-802*	0.6 - 0.65	45
1.191mm (3/64")	124-803*	0.7 - 0.8	35 - 30
1.5mm	124-821*	0.9 - 1	28 - 26
1.588mm (1/16")	124-804*	0.9 - 1	28 - 26
2mm	124-805*	1.25	22
2.381mm (3/32")	124-806	1.5	17
2.5mm	124-822	1.5	17
3mm	124-807	1.75	15
3.175mm (1/8")	124-808	—	14
3.5mm	124-823	2	13
3.969mm (5/32")	124-809	2	13
4mm	124-810	2.25	11
4.5mm	124-824	2.5	10
4.763mm (3/16")	124-811	2.5	10
5mm	124-812	2.75	9
5.556mm (7/32")	124-813	3.0 - 3.25	8
6mm	124-814	3.5	7
6.35mm (1/4")	124-815	3.75	7
7mm	124-816	4.0	6.5
7.144mm (9/32")	124-817	4.25	6
7.938mm (5/16")	124-818	4.5	5.5
8mm	124-819	4.75	5.5
8.731mm (11/32")	124-820	5.0 - 5.25	5

*Carbide-tipped type

Screw Thread Micrometers

SERIES 125

FEATURES

- Provided with a 60 degree V-anvil and conical spindle for easily measuring pitch diameters of metric or unified screw threads.
- With Ratchet Stop for constant force.
- With a standard bar for zero point adjustment except 0 - 25mm model.
- Supplied in fitted plastic case.



Technical Data

Accuracy: $\pm(2+R/75)\mu\text{m}$, R=max. range (mm)
 Graduation: 0.01mm
 Spindle feed error: $3\mu\text{m}$



SPECIFICATIONS

Metric

Range	Graduation	Order No.	Screw to be measured (Metric/Unified)
0 - 25mm	0.01mm	125-101	0.4 - 0.5mm/64 - 48TPI
		125-102	0.6 - 0.9mm/44 - 28TPI
		125-103	1 - 1.75mm/24 - 14TPI
		125-104	2 - 3mm/13 - 9TPI
		125-105	3.5 - 5mm/8 - 5TPI
25 - 50mm	0.01mm	125-106	0.4 - 0.5mm/64 - 48TPI
		125-107	0.6 - 0.9mm/44 - 28TPI
		125-108	1 - 1.75mm/24 - 14TPI
		125-109	2 - 3mm/13 - 9TPI
		125-110	3.5 - 5mm/8 - 5TPI
50 - 75mm	0.01mm	125-111	0.6 - 0.9mm/44 - 28TPI
		125-112	1 - 1.75mm/24 - 14TPI
		125-113	2 - 3mm/13 - 9TPI
		125-114	3.5 - 5mm/8 - 5TPI
		125-115	5.5 - 7mm/4.5 - 3.5TPI
75 - 100mm	0.01mm	125-116	0.6 - 0.9mm/44 - 28TPI
		125-117	1 - 1.75mm/24 - 14TPI
		125-118	2 - 3mm/13 - 9TPI
		125-119	3.5 - 5mm/8 - 5TPI
		125-120	5.5 - 7mm/4.5 - 3.5TPI

DIMENSIONS AND MASS

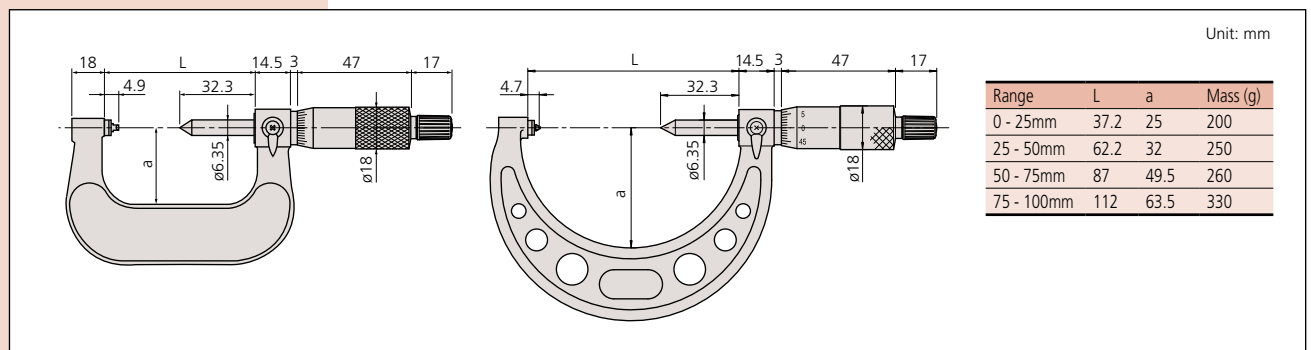

Screw Thread Micrometers

SERIES 326, 126 — Interchangeable Anvil-Spindle Tip Type



FEATURES

- IP65 water/dust protection (Series 326).
- 60 degree or 55 degree V-anvil and conical spindle (interchangeable) are optional, which are made of high-grade steel, hardened and precision ground.
- With Ratchet Stop for constant force.
- With SPC output (Series 326).
- With a standard bar except 0 - 25mm and 0 - 1" model.
- Supplied in fitted plastic case.



126-125
Shown with optional anvils

326-351-10

SPECIFICATIONS

Metric		Digital model		
Range	Resolution	Order No.	Accuracy	Mass (g)
0 - 25mm	0.001mm	326-251-10	±4µm	350
25 - 50mm	0.001mm	326-252-10	±4µm	380
50 - 75mm	0.001mm	326-253-10	±4µm	470
75 - 100mm	0.001mm	326-254-10	±5µm	510

Inch/Metric		Digital model		
Range	Resolution	Order No.	Accuracy	Mass (g)
0 - 1" / 0 - 25.4mm	.00005" / 0.001mm	326-351-10	±.0002"	350
1 - 2" / 25.4 - 50.8mm	.00005" / 0.001mm	326-352-10	±.0002"	380
2 - 3" / 50.8 - 76.2mm	.00005" / 0.001mm	326-353-10	±.0002"	470
3 - 4" / 76.2 - 101.6mm	.00005" / 0.001mm	326-354-10	±.00025"	510

Metric				
Range	Graduation	Order No.	Accuracy	Mass (g)
0 - 25mm	0.01mm	126-125	±4µm	240
25 - 50mm	0.01mm	126-126	±4µm	290
50 - 75mm	0.01mm	126-127	±4µm	390
75 - 100mm	0.01mm	126-128	±5µm	450
100 - 125mm	0.01mm	126-129	±5µm	530
125 - 150mm	0.01mm	126-130	±5µm	620
150 - 175mm	0.01mm	126-131	±6µm	730
175 - 200mm	0.01mm	126-132	±6µm	860
200 - 225mm	0.01mm	126-133	±6µm	1,030
225 - 250mm	0.01mm	126-134	±7µm	1,200
250 - 275mm	0.01mm	126-135	±7µm	1,370
275 - 300mm	0.01mm	126-136	±7µm	1,540

Inch				
Range	Graduation	Order No.	Accuracy	Mass (g)
0 - 1"	.001"	126-137	±.0002"	240
1 - 2"	.001"	126-138	±.0002"	290
2 - 3"	.001"	126-139	±.0002"	390
3 - 4"	.001"	126-140	±.00025"	450
4 - 5"	.001"	126-141	±.00025"	530
5 - 6"	.001"	126-142	±.00025"	620
6 - 7"	.001"	126-143	±.0003"	730

Inch With anvil set (126 - 800)				
Range	Graduation	Order No.	Accuracy	Mass (g)
0 - 1"	.001"	126-901	±.0002"	240
1 - 2"	.001"	126-902	±.0002"	290
2 - 3"	.001"	126-903	±.0002"	390
3 - 4"	.001"	126-904	±.00025"	450
4 - 5"	.001"	126-905	±.00025"	530
5 - 6"	.001"	126-906	±.00025"	620

DIMENSIONS

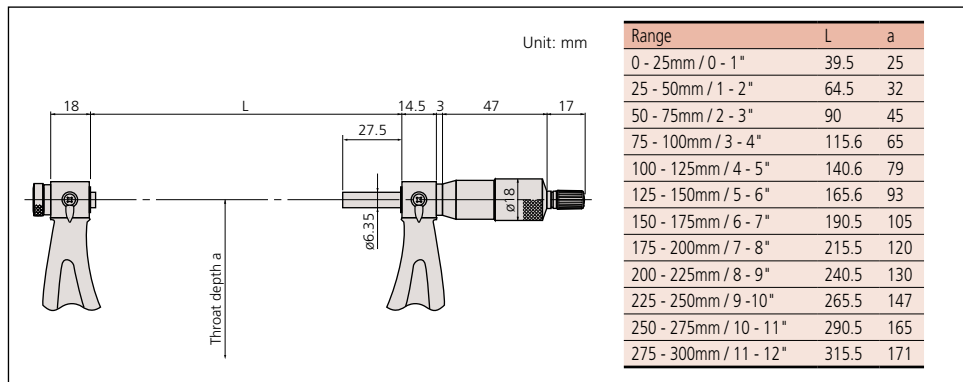

Technical Data

Resolution*: 0.001mm or .00005"/0.001mm
 Graduation**: 0.01mm or .001"
 Spindle feed error: 3µm / .00012"
 Display*: LCD
 Battery*: SR44 (1 pc.), **938882**
 Battery life*: Approx. 1.2 years under normal use
 Dust/Water protection level*: IP65
 *Digital models **Analog models

Function of Digital Model

Zero / ABS, Data hold, Data output, 2 Presets, Function Lock.
 inch/mm conversion (on inch/metric models only)
 Alarm: Low voltage, Counting value composition error

Optional Accessories

05CZA662: SPC cable with data switch (1m / 40")*
05CZA663: SPC cable with data switch (2m / 80")*
 *Only for digital models
 (See page B-51.): Standard for screw thread micrometer

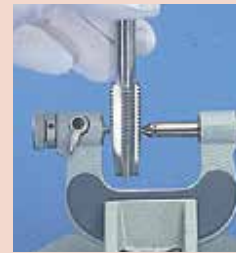

Anvil-spindle tip set:

Applications	Set Order No.	Tip Information		
		Threads Per Inch	Pitch (mm)	Individual Order No.
Metric Screw, Unified screw (60° threads)	126-800	64-48 (M1)	0.4-0.5	126-801
		44-28 (M2)	0.6-0.9	126-802
		24-14 (M3)	1-1.75	126-803
		13-9 (M4)	2-3	126-804
		8-5 (M5)	3.5-5	126-805
		4.5-3.5 (M6)	5.5-7	126-806
Whitworth Screw (55° threads)	126-810	60-48	-	126-811
		48-40	-	126-812
		40-32	-	126-813
		32-24	-	126-814
		24-18	-	126-815
		18-14	-	126-816
		14-10	-	126-817
		10-7	-	126-818
		7-4.5	-	126-819
		4.5-3.5	-	126-820

Features: 60 degree or 55 degree V-anvil and conical spindle (interchangeable) are optional, which are made of high-grade special steel, hardened and precision ground

Storage Box Included

3-Wire Thread Measuring System

Individual Holder and Wire Set

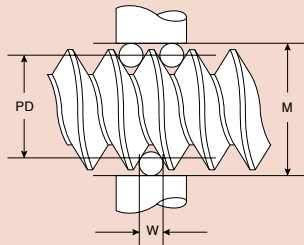

P.D. = Pitch Diameter
 M = Measurement over wires
 W = Wire diameter
 C = Constant
 C = .86603 x Pitch (inches) -3W
 P.D. = M-C
 W = .57735 x P

Applications

- Measure set of thread plug gages and working thread plug gages
- Monitor the wear on working thread plug gages
- Monitor and control pitch diameter variation during thread fabrication
- Reduce measurement time to a fraction of the time normally taken using the traditional three wire method
- Use in conjunction with "Go" and "No Go" thread ring gages to control thread size to the most demanding specifications
- Determine out of roundness and taper that may exist in threaded parts
- Applications for preplating and post plating thread measurement

Tolerance of Wires:

- Diameter +/- .000010"
- Roundness +/- .000010"
- Surface finish 2 micro inches AA, lapped.
- Hardness HRC 59-64
- Certification of accuracy included.
- Traceable to NIST.
- Meets or exceeds all ANSI and ISO specs.

FEATURES

- Fast and accurate method of thread measuring available for use with Micrometer

Wire holders and 3 thread measuring wires assembled for each thread pitch

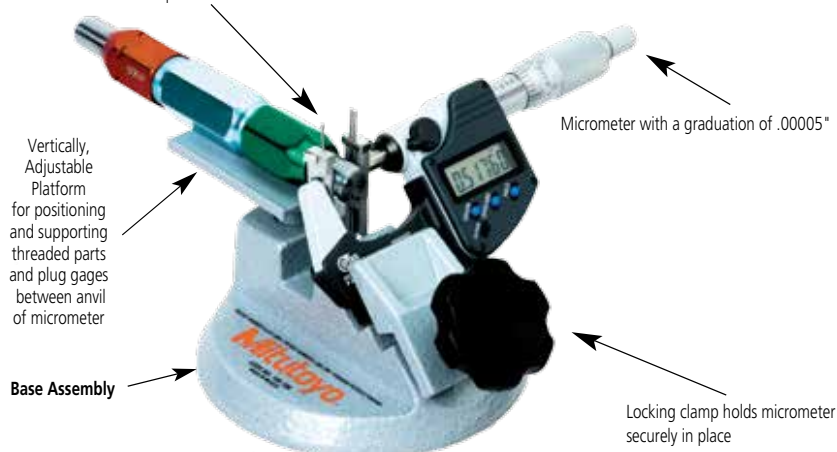

INCH STANDARD HOLDERS AND WIRES SETS

Order No.	Threads Per Inch	Thread Measuring Wire Diameter
64AAA201	120	.00481
64AAA202	100	.00577
64AAA203	95	.00601
64AAA204	90	.00642
64AAA205	80	.00722
64AAA206	72	.00802
64AAA207	64	.00902
64AAA208	56	.01031
64AAA209	50	.01155
64AAA210	48	.01203
64AAA211	44	.01312
64AAA212	40	.01443
64AAA213	36	.01604
64AAA214	32	.01804
64AAA215	30	.01925
64AAA216	28	.02062
64AAA217	27	.02138
64AAA218	26	.02221
64AAA219	24	.02406
64AAA220	22	.02624
64AAA221	20	.02887
64AAA222	18	.03208
64AAA223	16	.03608
64AAA224	14	.04124
64AAA225	13	.04441
64AAA226	12	.04811
64AAA227	11.5	.05020
64AAA228	11	.05249
64AAA229	10	.05774
64AAA230	9	.06415
64AAA231	8	.07217
64AAA232	7.5	.07698
64AAA233	7	.08248
64AAA234	6	.09623
64AAA235	5.5	.10497
64AAA236	5	.11547

Compatible with Micrometers with 0.25" Anvils & Spindles

Stand Assembly
 Order No. 156-106

METRIC HOLDERS AND WIRES SETS

Order No.	Pitch	mm Diameter	Inch Diameter
64AAA251	.2mm	.1155	.00455
64AAA252	.225mm	.1299	.00511
64AAA253	.25mm	.1443	.00568
64AAA254	.30mm	.1732	.00682
64AAA255	.35mm	.2021	.00796
64AAA256	.40mm	.2309	.00909
64AAA257	.45mm	.2598	.01023
64AAA258	.50mm	.2887	.01137
64AAA259	.55mm	.3175	.01250
64AAA260	.60mm	.3464	.01364
64AAA261	.70mm	.4041	.01591
64AAA262	.75mm	.4330	.01705
64AAA263	.80mm	.4619	.01818
64AAA264	.85mm	.4907	.01932
64AAA265	.90mm	.5196	.02046
64AAA266	1.00mm	.5774	.02273
64AAA267	1.25mm	.7217	.02841
64AAA268	1.50mm	.8660	.03410
64AAA269	1.75mm	1.0104	.03978
64AAA270	2.00mm	1.1547	.04546
64AAA271	2.50mm	1.4434	.05683
64AAA272	3.00mm	1.7321	.06819
64AAA273	3.50mm	2.0207	.07956
64AAA274	4.00mm	2.3094	.09092

Can Seam Micrometers

SERIES 147

FEATURES

- Measures the width, height, and depth of can seams.
- Three types of micrometers are available for: steel cans, aluminum cans, and sprayer cans.
- Supplied in fitted carton.



147-103

SPECIFICATIONS

Metric			
Range	Graduation	Order No.	Remarks
0 - 13mm	0.01mm	147-103	for steel cans
		147-105	for aluminum cans
		147-202	for sprayer cans

Inch			
Range	Graduation	Order No.	Remarks
0 - .5"	.001"	147-104	for steel cans
		147-106	for aluminum cans
		147-201	for sprayer cans

Technical Data

Accuracy: $\pm 0.00012'' / \pm 3\mu\text{m}$
 Graduation: .001" / 0.01mm

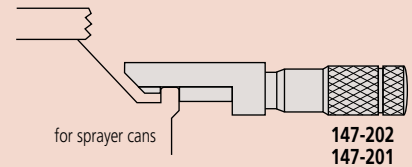
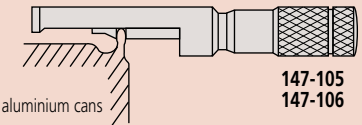
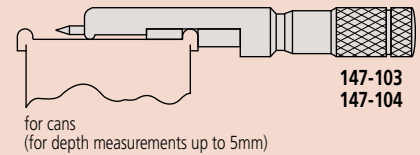

DIMENSIONS AND MASS

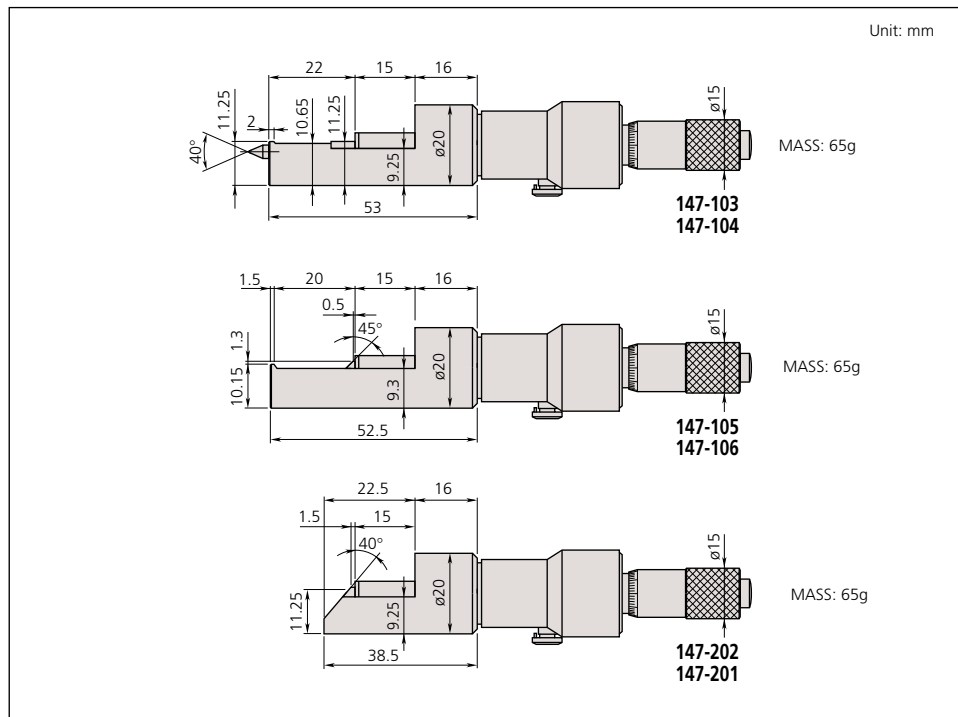

Hub Micrometers

SERIES 147

Technical Data

Accuracy: Refer to the list of specifications.
 Graduation: 0.01mm / .001"
 Flatness: 0.6µm / .000024"
 Parallelism: (2+R/100)µm, R=max. range (mm)
 [.00008" + .00004" (L/4)]", L = Max. range (inch).
 Measuring faces: Carbide tipped

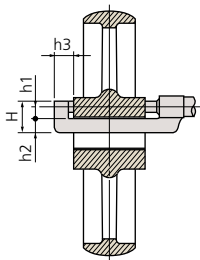

Unit: mm

Range	h1	h2	h3	H	Mass (g)
0 - 1" / 0 - 25mm	6	8.5	13.5	17.5	135
1 - 2" / 25 - 50mm	6.5	11	14	20.5	150
3 - 4" / 50 - 75mm	6.5	11	13	20.5	170
4 - 5" / 75 - 100mm	6.5	11	13	20.5	185

FEATURES

- Measures hub thickness and shoulders inside a bore.
- With Ratchet Stop for constant force.
- With a standard bar except for 0 - 1" / 0 - 25mm model.
- Supplied in fitted plastic case.



147-301



147-351

SPECIFICATIONS

Metric			
Range	Graduation	Order No.	Accuracy
0 - 25mm	0.01mm	147-301	±2µm
25 - 50mm	0.01mm	147-302	±2µm
50 - 75mm	0.01mm	147-303	±2µm
75 - 100mm	0.01mm	147-304	±3µm

Inch			
Range	Graduation	Order No.	Accuracy
0 - 1"	.001"	147-351	±.0001"
1 - 2"	.001"	147-352	±.0001"
2 - 3"	.001"	147-353	±.0001"
3 - 4"	.001"	147-354	±.00015"

Wire Micrometers

SERIES 147

FEATURES

- Designed for measuring wire thickness.
- Also used to measure the diameter of a small ball.
- Supplied in fitted plastic case.



147-402



147-401

SPECIFICATIONS

Metric				
Range	Graduation	Order No.	Accuracy	Mass (g)
0 - 10mm	0.01mm	147-401	±3µm	65

Inch				
Range	Graduation	Order No.	Accuracy	Mass (g)
0 - .4"	.0001"	147-402*	±.00015"	65

* .0001" reading is obtained with vernier

Technical Data

Graduation: .0001" or 0.01mm
 Flatness: .000024" / 0.6µm
 Parallelism: .00005" / 1.3µm
 Measuring faces: Carbide tipped



DIMENSIONS AND MASS

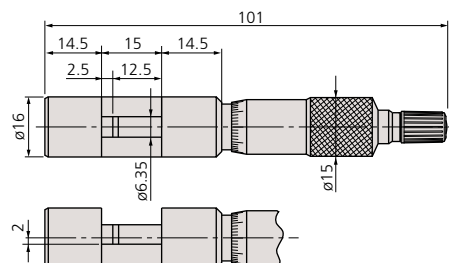

Unit: mm
 MASS = 65g

Digital Outside Micrometers

SERIES 193

FEATURES

- Mechanical digit counter with 0.01mm or .001" reading for quick and error-free reading.
- With a standard bar except for 0-25mm / 0 -1" model.
- Supplied in fitted plastic case.



193-211

Technical Data

Counter reading: 0.01mm or .001"
 Graduation: 0.01mm, 0.001mm, .001" or .0001"
 Flatness: 0.6μm / .000024"
 Parallelism: (2+R/100)μm, R=max. range (mm)
 [.00008" + .00004" (L/4)]", L= max. range (inch)
 Measuring faces: Carbide tipped



193-916

SPECIFICATIONS

Metric _____ With ratchet stop

Range	Graduation	Order No.	Accuracy
0 - 25mm	0.01mm	193-101	±2μm
	0.001mm	193-111*	±2μm
25 - 50mm	0.01mm	193-102	±2μm
	0.001mm	193-112*	±2μm
50 - 75mm	0.01mm	193-103	±2μm
	0.001mm	193-113*	±2μm
75 - 100mm	0.01mm	193-104	±3μm
	0.001mm	193-114*	±3μm

*0.001mm reading is obtained with vernier.

Inch _____ With friction thimble

Range	Graduation	Order No.	Accuracy
0 - 25mm	.0001"	193-211*	±.0001"
	.0001"	193-212*	±.0001"

*.0001" reading is obtained with vernier.

Inch _____ With ratchet stop

Range	Graduation	Order No.	Accuracy
2 - 3"	.0001"	193-213*	±.0001"
3 - 4"	.0001"	193-214*	±.00015"

*.0001" reading is obtained with vernier.

Metric _____ Micrometer sets

Range	Order No.	Included in set
0 - 75mm (3 pcs./set)	193-901	• 193-101, 193-102, 193-103 • 2 micrometer standards
0 - 75mm (3 pcs./set)	193-915	• 193-111, 193-112, 193-113, • 2 micrometer standards
0 - 100mm (4 pcs./set)	193-902	• 193-101, 193-102, 193-103, 193-104 • 3 micrometer standards
0 - 100mm (4 pcs./set)	193-916	• 193-111, 193-112, 193-113, 193-114 • 3 micrometer standards

Inch _____ Micrometer sets

Range	Order No.	Included in set
0 - 3" (3 pcs./set)	193-923	• 193-211, 193-212, 193-213 • 2 micrometer standards

DIMENSIONS AND MASS

Models up to 100mm / 4"

Unit: mm

Range	L	a	b	c	Mass (g)
0 - 25mm / 0 - 1"	30	2.5	5	26	224
25 - 50mm / 1 - 2"	55	2.5	8	32	275
50 - 75mm / 2 - 3"	80	2.5	9	45	379
75 - 100mm / 3 - 4"	105	2.5	9	57	489

Note: The shape of the thimble changes on the model with Friction Thimble.

Technical Data

Spindle feed error: $3\mu\text{m} / .00012''$
 Dial indication accuracy: $1\mu\text{m} / .00004''$
 Dispersion of indication: $0.4\mu\text{m} / .00002''$
 Graduation: 0.001mm or $.0001''$
 Dial reading: 0.001mm or $.00005''$
 Flatness: $0.3\mu\text{m} / .000012''$
 Parallelism: $0.6\mu\text{m} / .000024''$ for models up to $50\text{mm} / 2''$
 $1\mu\text{m} / .00004''$ for models over $50\text{mm} / 2''$
 Measuring force: $5 - 10\text{N}$ ($500 - 1000\text{gf}$)
 Measuring faces: Carbide tipped



Optional Accessories

04AZA124: $\phi 16\text{mm} / \phi .63''$ workpiece stopper
 (not available for $25\text{mm} / 1''$ model)
04AZA125: $\phi 14\text{mm} / \phi .55''$ workpiece stopper
04AZA126: $\phi 14\text{mm} / \phi .55''$ workpiece stopper

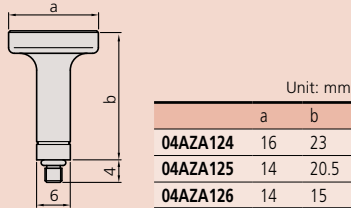

DIMENSIONS AND MASS

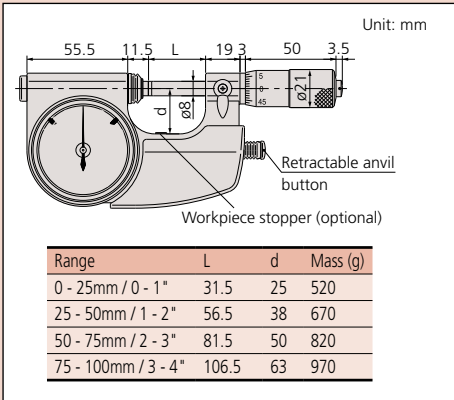

Technical Data

Flatness: $0.3\mu\text{m} / .000012''$
 Parallelism: $0.6\mu\text{m} / .000024''$ for models up to $50\text{mm} / 2''$
 $1\mu\text{m} / .00004''$ for models over $50\text{mm} / 2''$
 Measuring force: $5 - 10\text{N}$ ($500 - 1000\text{gf}$)
 Measuring faces: Carbide tipped

DIMENSIONS AND MASS

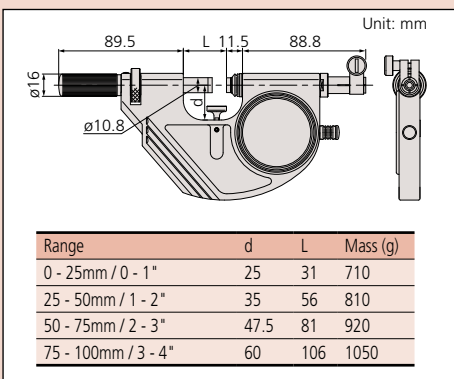

Indicating Micrometers

SERIES 510

FEATURES

- Retractable anvil with indicator for three-wire measurements of pitch diameter of precision screws and parallelism measurements.
- With a standard bar except for 0 - 25mm / 0 - 1" model.
- IP protection level: 54
- Supplied in fitted plastic case.



510-131

SPECIFICATIONS

Metric			
Range	Graduation	Order No.	Indicating range
0 - 25mm	0.001mm	510-121* 510-141	$\pm 0.060\text{mm}$
25 - 50mm	0.001mm	510-122	$\pm 0.060\text{mm}$
50 - 75mm	0.001mm	510-123	$\pm 0.060\text{mm}$
75 - 100mm	0.001mm	510-124	$\pm 0.060\text{mm}$

*Retractable anvil button on the right side.

Inch			
Range	Graduation	Order No.	Indicating range
0 - 1"	.00005"	510-131* 510-151	$\pm .0023''$
1 - 2"	.00005"	510-132	$\pm .0023''$
2 - 3"	.00005"	510-133	$\pm .0023''$
3 - 4"	.00005"	510-134	$\pm .0023''$

*Retractable anvil button on the right side.

Snap Meters

SERIES 523

FEATURES

- Various types of indicators, LVDT's and Linear Gages can be selected according to the measurement applications.
- Supplied in fitted plastic case.



523-141

Indicator is optional

SPECIFICATIONS

Metric			Gage stem dia 8mm
Range	Order No.	Anvil movement	
0 - 25mm	523-141	2mm	
25 - 50mm	523-142	2mm	
50 - 75mm	523-143	2mm	
75 - 100mm	523-144	2mm	

Inch			Gage stem dia 3/8"
Range	Order No.	Anvil movement	
0 - 1"	523-151	.078"	
1 - 2"	523-152	.078"	
2 - 3"	523-153	.078"	
3 - 4"	523-154	.078"	

Dial Snap Meters

SERIES 523

FEATURES

- Direct GO/NO-GO judgment for mass-produced parts.
- Spindle diameter: .425" / 10.8mm
- IP protection level: 54
- Supplied in fitted plastic case.



523-131



Technical Data

Dial indication accuracy: .00005" / 1µm
 Indication repeatability: .00002" / 0.4µm
 Dial reading: .00005" or 0.001mm
 Flatness: .000012" / 0.3µm
 Parallelism: .000024" / 0.6µm for models up to 2" / 50mm
 .00004" / 1µm for models over 2" / 50mm
 Measuring force: 5 - 10N (500 - 1000gf)
 Measuring faces: Carbide tipped

SPECIFICATIONS

Metric

Range	Graduation	Order No.	Indicating range
0 - 25mm	0.001mm	523-121	±0.060mm
25 - 50mm	0.001mm	523-122	±0.060mm
50 - 75mm	0.001mm	523-123	±0.060mm
75 - 100mm	0.001mm	523-124	±0.060mm

Inch

Range	Graduation	Order No.	Indicating range
0 - 1"	.00005"	523-131	±.0023"
1 - 2"	.00005"	523-132	±.0023"
2 - 3"	.00005"	523-133	±.0023"
3 - 4"	.00005"	523-134	±.0023"

DIMENSIONS AND MASS

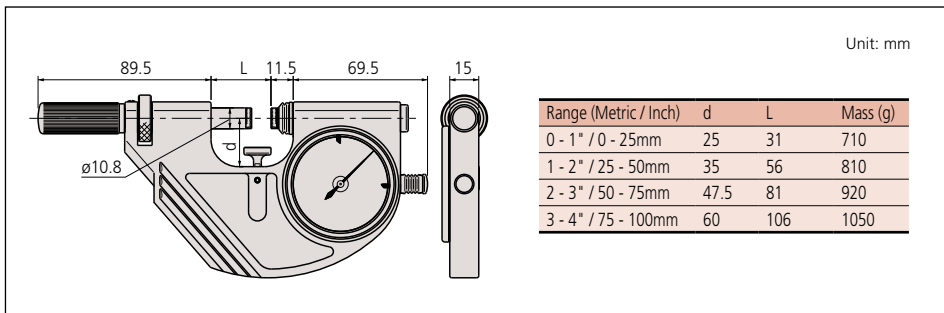

Caliper Type Micrometers

SERIES 343, 143

Technical Data

Accuracy: Refer to the list of specifications.
 Resolution*: 0.001mm or .00005"/0.001mm
 Graduation**: 0.01mm / .001"
 Flatness: 0.3 μ m / .000012"
 Parallelism: (3+R/75) μ m, R=max. range (mm) [.00012" + .00004" (L/8)]"
 L = Max. range (inch)
 Measuring faces: Carbide tipped
 Display*: LCD
 Battery*: SR44 (1 pc.), **938882**
 Battery life*: Approx. 1.2 years under normal use
 *Digital models **Analog models

Function of Digital Model

Origin-set, Zero-setting, Data hold, Data output, inch/mm conversion (on inch/metric models only)
 Alarm: Low voltage, Counting value composition error

Optional Accessories for Digital Model

05CZA662: SPC cable with data switch (1m / 40")
05CZA663: SPC cable with data switch (2m / 80")

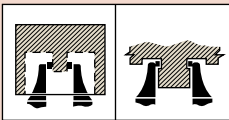

FEATURES

- With Ratchet Stop for constant force.
- With SPC output (Series 343).
- With a standard bar except 0 - 25mm and 0 - 1" model.
- Supplied in fitted plastic case.



143-121



343-250

SPECIFICATIONS

Metric Digital model

Range	Resolution	Order No.	Accuracy	Mass (g)
0 - 25mm	0.001mm	343-250	$\pm 5\mu$ m	630
25 - 50mm	0.001mm	343-251	$\pm 6\mu$ m	650
50 - 75mm	0.001mm	343-252	$\pm 7\mu$ m	1040
75 - 100mm	0.001mm	343-253	$\pm 8\mu$ m	1090

Inch / Metric Digital model

Range	Resolution	Order No.	Accuracy	Mass (g)
0 - 1" / 0 - 25.4mm	.00005" / 0.001mm	343-350	$\pm .00025"$	630
1 - 2" / 25.4 - 50.8mm	.00005" / 0.001mm	343-351	$\pm .0003"$	650
2 - 3" / 50.8 - 76.2mm	.00005" / 0.001mm	343-352	$\pm .00035"$	1040
3 - 4" / 76.2 - 101.6mm	.00005" / 0.001mm	343-353	$\pm .0004"$	1090

Metric

Range	Graduation	Order No.	Accuracy	Mass (g)
0 - 25mm	0.01mm	143-101	$\pm 5\mu$ m	210
25 - 50mm	0.01mm	143-102	$\pm 6\mu$ m	230
50 - 75mm	0.01mm	143-103	$\pm 7\mu$ m	280
75 - 100mm	0.01mm	143-104	$\pm 8\mu$ m	330

Models with a range up to 300mm are available.

Inch

Range	Graduation	Order No.	Accuracy	Mass (g)
0 - 1"	.001"	143-121	$\pm .00025"$	210
1 - 2"	.001"	143-122	$\pm .0003"$	230
2 - 3"	.001"	143-123	$\pm .00035"$	280

DIMENSIONS

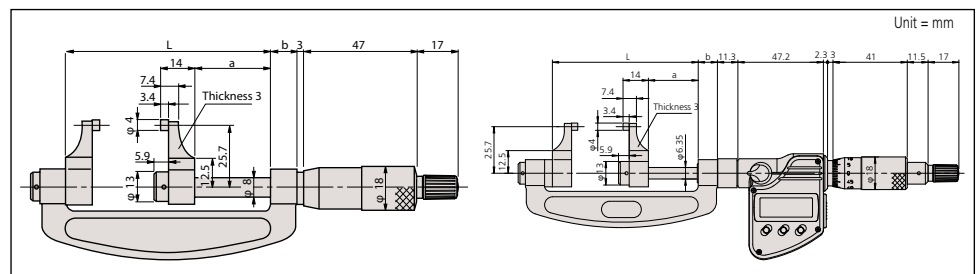

Groove Micrometers

SERIES 146

FEATURES

- Flanged spindle for measuring width, depth, and location of grooves inside/outside bores, and tubes.
- Provided with two types of graduations for inside and outside measurements.
- Non-rotating spindle type has two-directional ratchet stop. (Measuring force: 0.7 - 1.2N)



SPECIFICATIONS

Metric Rotating spindle type

Range Outside	Range Inside	Graduation	Order No.	Flange	Mass (g)
0 - 25mm	1.6 - 26.5mm	0.01mm	146-121	ø6.35mm	135
			146-122	ø12.7mm	185
25 - 50mm	26.5 - 51.5mm	0.01mm	146-123	ø12.7mm	175
50 - 75mm	51.5 - 76.5mm	0.01mm	146-124	ø12.7mm	165
75 - 100mm	76.5 - 101.5mm	0.01mm	146-125	ø12.7mm	160

Inch Rotating spindle type

Range Outside	Range Inside	Graduation	Order No.	Flange	Mass (g)
0 - 1"	.055" - 1.05"	.001"	146-131	ø.25"	135
			146-132	ø.5"	185
1" - 2"	1.05" - 2.05"	.001"	146-133	ø.5"	175
2" - 3"	2.05" - 3.05"	.001"	146-134	ø.5"	165
3" - 4"	3.05" - 4.05"	.001"	146-135	ø.5"	160

Metric Non-rotating spindle type

Range Outside	Range Inside	Graduation	Order No.	Flange	Mass (g)
0 - 25mm	1.6 - 26.5mm	0.01mm	146-221	ø6.35mm	135
			146-222	ø12.7mm	185
25 - 50mm	26.5 - 51.5mm	0.01mm	146-223	ø12.7mm	175
50 - 75mm	51.5 - 76.5mm	0.01mm	146-224	ø12.7mm	165
75 - 100mm	76.5 - 101.5mm	0.01mm	146-225	ø12.7mm	160

Inch Non-rotating spindle type

Range Outside	Range Inside	Graduation	Order No.	Flange	Mass (g)
0 - 1"	.055" - 1.05"	.001"	146-231	ø.25"	135
			146-232	ø.5"	185
1" - 2"	1.05" - 2.05"	.001"	146-233	ø.5"	175
2" - 3"	2.05" - 3.05"	.001"	146-234	ø.5"	165
3" - 4"	3.05" - 4.05"	.001"	146-235	ø.5"	160

DIMENSIONS

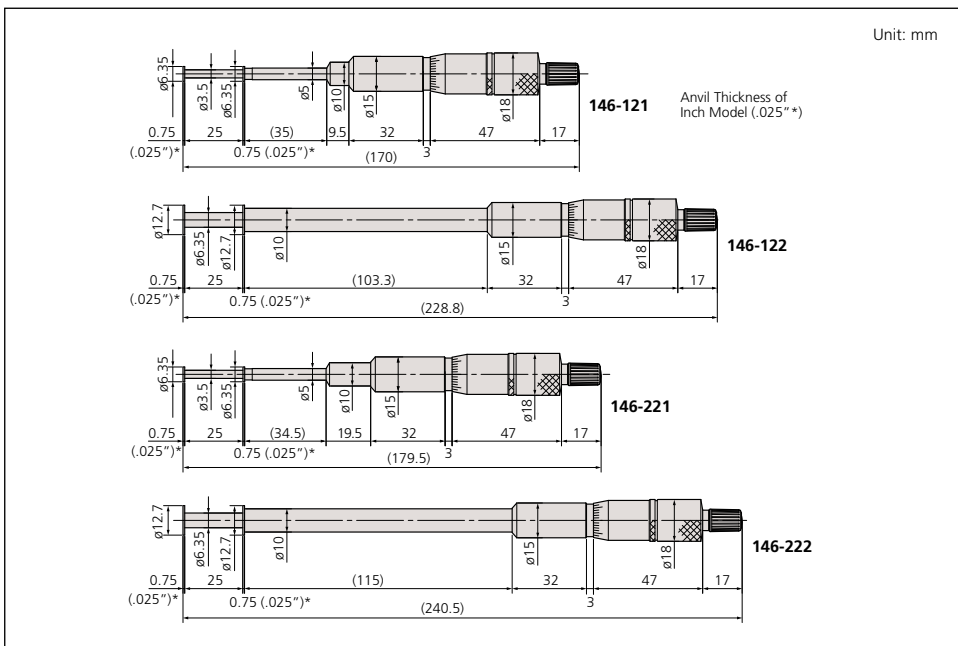

Technical Data

Accuracy: $\pm .0004"$ / $\pm 10\mu\text{m}$

Parallelism: $.0004"$ / $10\mu\text{m}$

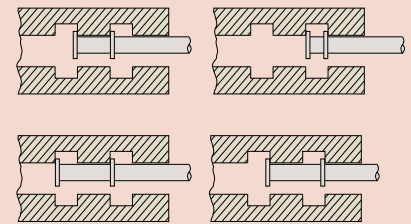

Small Hole Gage Set

SERIES 154

FEATURES

- Used with an outside micrometer for measuring inside diameter of bores.
- 4 sizes of gages are supplied in a fitted pouch.
- Extra long for gaging deep and shallow holes, slots, and similar workpieces.
- Gaging surface is fully hardened to insure long tool life.



154-901

DIMENSIONS

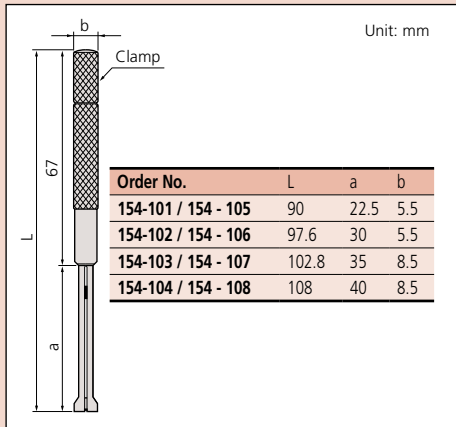

SPECIFICATIONS

Metric		
Total range	Set Order No.	Assortment of gages
ø3 - 13mm (4-gage set)	154-902	ø3 - 5mm gage (154-101)
		ø5 - 7.5mm gage (154-102)
		ø7.5 - 10mm gage (154-103)
		ø10 - 13mm gage (154-104)

Inch		
Total range	Set Order No.	Assortment of gages
.125 - .5" DIA. (4-gage set)	154-901	.125" - .2" DIA. gage (154-105)
		.2" - .3" DIA. gage (154-106)
		.3" - .4" DIA. gage (154-107)
		.4" - .5" DIA. gage (154-108)

Telescoping Gage Set

SERIES 155

FEATURES

- Spring-loaded plunger expands within the bore (or groove), allowing determination of the internal diameter (or groove width).
- With a knurled clamp.
- Supplied in a fitted pouch.



155-903

DIMENSIONS

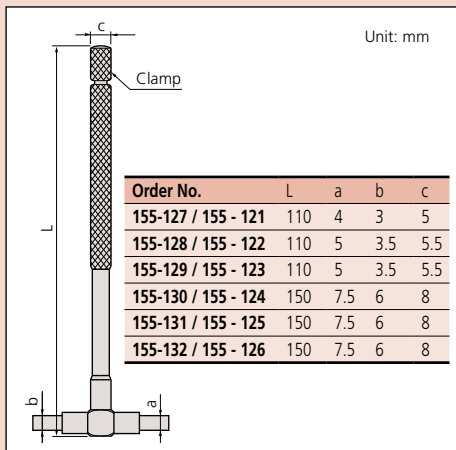

SPECIFICATIONS

Metric		
Total range	Set Order No.	Included in set
8 - 150mm (6-gage set)	155-905	8 - 12.7mm gage (155-127)
		12.7 - 19mm gage (155-128)
		19 - 32mm gage (155-129)
		32 - 54mm gage (155-130)
		54 - 90mm gage (155-131)
		90 - 150mm gage (155-132)

Inch		
Total range	Set Order No.	Included in set
.313 - 6" (6-gage set)	155-903	.313" - .5" gage (155-121)
		.5" - .75" gage (155-122)
		.75" - 1.25" gage (155-123)
		1.25" - 2.125" gage (155-124)
		2.125" - 3.5" gage (155-125)
		3.5" - 6" gage (155-126)
.50 - 6" (5-gage set)	155-904	155-122, 155-123, 155-124, 155-125, 155-126
.315 - 2.125" (4-gage set)	155-907	155-121, 155-122, 155-123, 155-124

Micrometer Stands

SERIES 156

These stands are designed to allow bench-top use with hand micrometers or other gages.

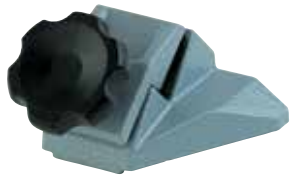

156-105-10



156-106



156-101-10



156-102

SPECIFICATIONS

Micrometer ranges	Order No.	Remarks
0-1" / 0-25mm, 1-2" / 25-50mm	156-105-10	Fixed angle type
Up to 4" / 100mm	156-101-10	Adjustable angle type
5-12" / 125-300mm	156-102	Vertical type
12-40" / 300-1000mm	156-103	Vertical type
0-1" / 0-25mm 1-2" / 25-50mm	156-106	Fixed angle with platform

DIMENSIONS

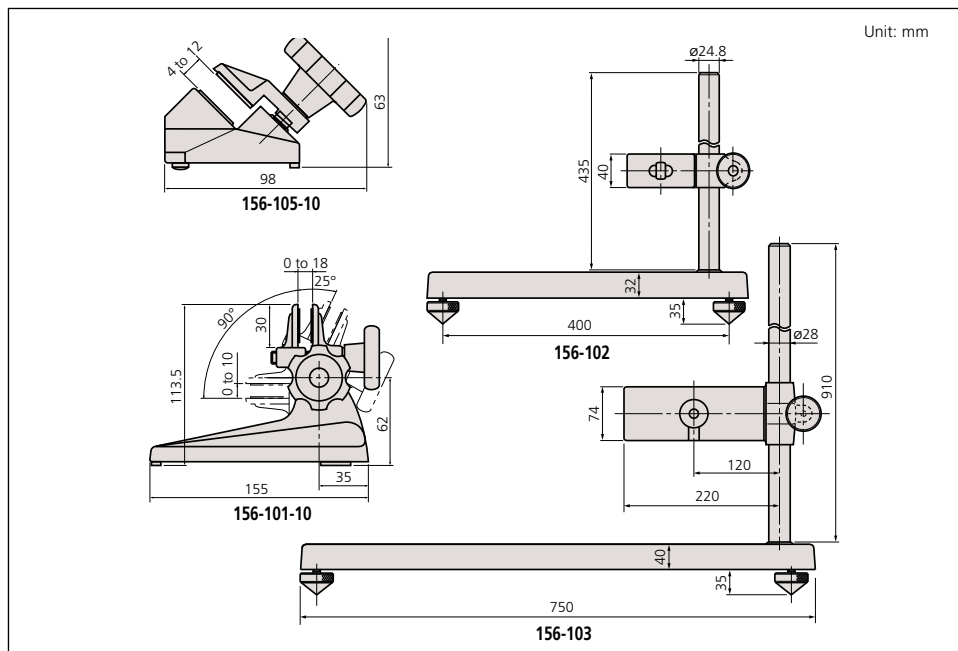

Color Ratchet & Color Speeder

Color ratchet



SPECIFICATIONS

Order No.	Color
985056	Black
985061	Red
985081	Blue
985071	Yellow
985076	Green
985066	Brown
04GZA241*	Gray
04GZA239**	Gray
04GZA243***	Gray

*for Series 293 digital model
 ** up to 300mm / 12"
 *** over 300mm / 12"

Color speeder for Ratchet Thimble Micrometer



SPECIFICATIONS

Order No.	Color
04GAA899	Black
04GAA900	Red
04GAA901	Yellow
04GAA902	Green
04GAA903	Blue
04AAB208	Gray

Technical Data

Tip length: metric type: 10mm ±5μm
 inch type: .5" ±.0002"

Spindle Dia: ¹ .250" / 6.35mm
¹Spindle diameter for 101469
 (.250" ball) is .315" / 8mm



Spindle Attachment Tip

Ball	Spline	Comparator	Blade	Knife-edge	Disk
101468 (.200" ball dia.) 101469 (.250" ball dia.)	208062* 208098	208063* 208099	208064* 208100	208065* 208101	208066* 208102

DIMENSIONS

Order No.	Dimension
208098 208062*	
208099 208063*	
208100 208064*	

Order No.	Dimension
208101 208065*	
208102 208066*	

* metric type

To measure odd workpieces, several convenient anvil attachments are prepared by MITUTOYO. Among them the most often used one is the ball attachment.

The ball attachments are hardened steel balls with .200" and .250" diameters which are placed on the .250" and .315" diameter anvils, respectively, by rubber caps. With these attachments, regular micrometers can measure cylindrical wall thickness, but, .200" or .250" must be subtracted from the readings.

Other attachments shown here are either .500" or 10mm in length. The added amount must be subtracted from the reading.

Micrometer Oil

207000 (30ml)



Mitutoyo

Optical Parallels

SERIES 157

FEATURES

- Designed to inspect parallelism and flatness of measuring faces of micrometers.
- Each set consists of 4 thicknesses.
- Supplied in fitted wooden case.



SPECIFICATIONS

Metric		
Range of micrometer to be checked	Order No.	Assortment of parallels (Thickness of parallel)
0-25mm	157-903	12.00mm (157-101)
		12.12mm (157-102)
		12.25mm (157-103)
		12.37mm (157-104)
25-50mm	157-904	25.00mm (157-105)
		25.12mm (157-106)
		25.25mm (157-107)
		25.37mm (157-108)

Inch		
Range of micrometer to be checked	Order No.	Assortment of parallels (Thickness of parallel)
0-1"	157-901	.5000" (157-109)
		.5062" (157-110)
		.5125" (157-111)
		.5187" (157-112)
		1-2"
1.0062" (157-114)		
1.0125" (157-115)		
1.0187" (157-116)		

Optical Flats

SERIES 158

FEATURES

- Used for inspecting the flatness of micrometer's or gage block's measuring faces with high accuracy.
- Supplied in fitted wooden case.



SPECIFICATIONS

Metric		
Flatness	Order No.	Diameter/Thickness
0.2μm	158-117	45mm/12mm
	158-119	60mm/15mm
0.1μm	158-118	45mm/12mm
	158-120	60mm/15mm

Inch		
Flatness	Order No.	Diameter/Thickness
.000004"	158-122	1.8"/.5"
	158-124	2.4"/.6"

Technical Data

Flatness: .000004" / 0.1μm
 Parallelism: .000008" / 0.2μm
 Diameter: 1.18" / 30mm

Parallelism Check between Measuring Faces by Means of Interference Fringe Produced by an Optical Parallel

The parallelism between the measuring faces can be determined as follows; place the optical parallel to the anvil and observe the number of interference fringes produced on the spindle side under the measuring force of the micrometers.
 The parallelism is about 1μm (0.32μm x 3 = 0.96μm). Fringe on the anvil side must not be more than one.

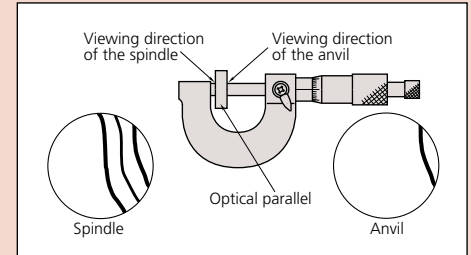

Flatness Check of Measuring Faces Using Interference Fringe Pattern Produced by an Optical Flat

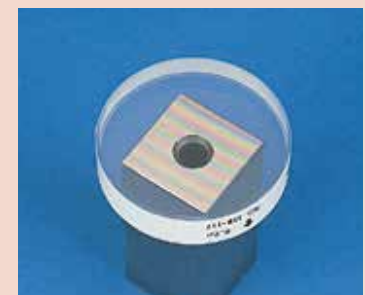
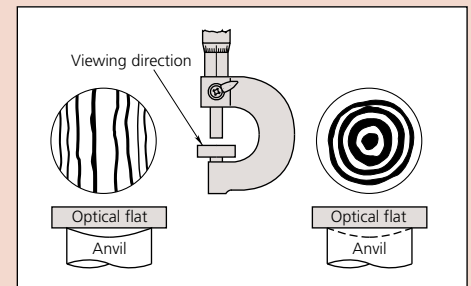

Technical Data

Flatness: 0.3µm / .000012"
 Parallelism: 2µm / .00008"



Micrometer Standards

SERIES 167

FEATURES

- Used for the zero point setting of outside micrometers.
- Flat and lapped measuring faces.
- Heat insulating handle to prevent expansion due to body temperature.
- Supplied in fitted carton up to 500mm / 20" and wooden case for over 525mm / 21", length.



DIMENSION

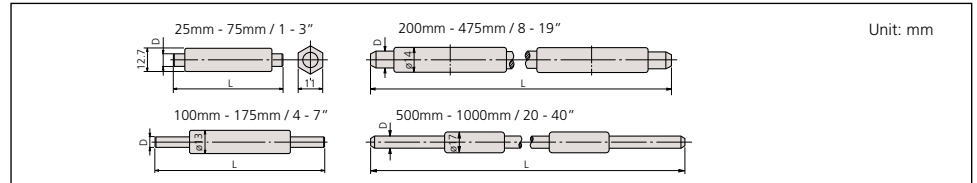

SPECIFICATIONS

Inch			
Length (L)	Order No.	Diameter (D)	Accuracy
41"	167-405	.47"	.0004"
42"	167-406	.47"	.0004"
43"	167-407	.47"	.0004"
44"	167-408	.47"	.0004"
45"	167-409	.47"	.0004"
46"	167-410	.47"	.0004"
47"	167-411	.47"	.0004"
48"	167-412	.47"	.0004"
49"	167-413	.47"	.0004"
50"	167-414	.47"	.0004"
51"	167-415	.47"	.0004"
52"	167-416	.47"	.0004"
53"	167-417	.47"	.0004"
54"	167-418	.47"	.0004"
55"	167-419	.47"	.0004"
56"	167-420	.47"	.0004"
57"	167-421	.47"	.0004"
58"	167-422	.47"	.0004"
59"	167-423	.47"	.0004"
60"	167-424	.47"	.0004"
61"	167-425	.47"	.0004"
62"	167-426	.47"	.0004"
63"	167-427	.47"	.0004"
64"	167-428	.47"	.0004"
65"	167-429	.47"	.0004"
66"	167-430	.47"	.0004"
67"	167-431	.47"	.0004"
68"	167-432	.47"	.0004"
69"	167-433	.47"	.0004"
70"	167-434	.47"	.0004"
71"	167-435	.47"	.0004"
72"	167-436	.47"	.0004"
73"	167-437	.47"	.0004"
74"	167-438	.47"	.0004"
75"	167-439	.47"	.0004"
76"	167-440	.47"	.0004"
77"	167-441	.47"	.0004"
78"	167-442	.47"	.0004"
79"	167-443	.47"	.0004"

Metric			
Length (L)	Order No.	Diameter (D)	Accuracy
25mm	167-101	6.35mm	±1.5µm
50mm	167-102	6.35mm	±2.0µm
75mm	167-103	6.35mm	±2.5µm
100mm	167-104	7.9mm	±3µm
125mm	167-105	7.9mm	±3.5µm
150mm	167-106	7.9mm	±4µm
175mm	167-107	7.9mm	±4.5µm
200mm	167-108	9.4mm	±5.0µm
225mm	167-109	9.4mm	±5.5µm
250mm	167-110	9.4mm	±6.0µm
275mm	167-111	9.4mm	±6.5µm
300mm	167-112	9.4mm	±7µm
325mm	167-113	9.4mm	±7.5µm
350mm	167-114	9.4mm	±8µm
375mm	167-115	9.4mm	±8.5µm
400mm	167-116	9.4mm	±9µm
425mm	167-117	9.4mm	±9.5µm
450mm	167-118	9.4mm	±1.0µm
475mm	167-119	9.4mm	±10.5µm
500mm	167-120	11.9mm	±11µm
525mm	167-121	11.9mm	±11.5µm
550mm	167-122	11.9mm	±12µm
575mm	167-123	11.9mm	±12.5µm
600mm	167-124	11.9mm	±13µm
625mm	167-125	11.9mm	±13.5µm
650mm	167-126	11.9mm	±14µm
675mm	167-127	11.9mm	±14.5µm
700mm	167-128	11.9mm	±15µm
725mm	167-129	11.9mm	±15.5µm
750mm	167-130	11.9mm	±16µm
775mm	167-131	11.9mm	±16.5µm
800mm	167-132	11.9mm	±17µm
825mm	167-133	11.9mm	±17.5µm
850mm	167-134	11.9mm	±18µm
875mm	167-135	11.9mm	±18.5µm
900mm	167-136	11.9mm	±19µm
925mm	167-137	11.9mm	±19.5µm
950mm	167-138	11.9mm	±20µm
975mm	167-139	11.9mm	±20.5µm
1000mm	167-140	11.9mm	±21µm

Inch			
Length (L)	Order No.	Diameter (D)	Accuracy
1"	167-141	.25"	±.000005"
2"	167-142	.25"	±.0001"
3"	167-143	.25"	±.0001"
4"	167-144	.31"	±.0001"
5"	167-145	.31"	±.00015"
6"	167-146	.31"	±.00015"
7"	167-147	.31"	±.00015"
8"	167-148	.37"	±.00015"
9"	167-149	.37"	±.0002"
10"	167-150	.37"	±.0002"
11"	167-151	.37"	±.0002"
12"	167-152	.37"	±.00025"
13"	167-153	.37"	±.00025"
14"	167-154	.37"	±.00025"
15"	167-155	.37"	±.00025"
16"	167-156	.37"	±.00025"
17"	167-157	.37"	±.00025"
18"	167-158	.37"	±.00025"
19"	167-159	.37"	±.0003"
20"	167-160	.47"	±.0003"
21"	167-161	.47"	±.0003"
22"	167-162	.47"	±.0003"
23"	167-163	.47"	±.0003"
24"	167-164	.47"	±.0003"
25"	167-165	.47"	±.00035"
26"	167-166	.47"	±.00035"
27"	167-167	.47"	±.00035"
28"	167-168	.47"	±.00035"
29"	167-169	.47"	±.00035"
30"	167-170	.47"	±.00035"
31"	167-171	.47"	±.00035"
32"	167-172	.47"	±.00035"
33"	167-173	.47"	±.00035"
34"	167-174	.47"	±.00035"
35"	167-175	.47"	±.00035"
36"	167-176	.47"	±.00035"
37"	167-177	.47"	±.0004"
38"	167-178	.47"	±.0004"
39"	167-179	.47"	±.0004"
40"	167-180	.47"	±.0004"

Micrometer Standards Set

Inch		
Order No.	Size	Remarks
167-912*	1"-5"	5 pcs. Set (167-141, 142, 143, 144, 145)
167-913*	1"-11"	11 pcs. Set (167-141, 142, 143, 144, 145, 146, 147, 148, 149, 150, 151)

Metric		
Order No.	Size	Remarks
167-902*	25-125mm	5 pcs. Set (167-101, 102, 103, 104, 105)
167-903*	25-275mm	11 pcs. Set (167-101, 102, 103, 104, 105, 106, 107, 108, 109, 110, 111)

*Supplied with fitted carrying case

Standards for Screw Thread Micrometers

SERIES 167 — 60 degree and 55 degree

FEATURES

- Specially designed for the zero point setting of screw thread micrometers.
- Supplied in fitted carton.



SPECIFICATIONS

Metric			
Length	Order No.	Thread angle	Accuracy
25mm	167-261	60°	±4µm
	167-272	55°	±4µm
50mm	167-262	60°	±5µm
	167-273	55°	±5µm
75mm	167-263	60°	±6µm
	167-274	55°	±6µm
100mm	167-264	60°	±7µm
	167-275	55°	±7µm
125mm	167-265	60°	±8µm
	167-276		±8µm
150mm	167-266	60°	±9µm
	167-277		±9µm
175mm	167-267	60°	±10µm
	167-278		±10µm
200mm	167-268	60°	±11µm
	167-279		±11µm
225mm	167-269	60°	±12µm
	167-280		±12µm
250mm	167-270	60°	±13µm
	167-281		±13µm
275mm	167-271	60°	±14µm
	167-282		±14µm

Inch			
Length	Order No.	Thread angle	Accuracy
1"	167-294	60°	±.00015"
	167-283	55°	±.00015"
2"	167-295	60°	±.0002"
	167-284	55°	±.0002"
3"	167-296	60°	±.00025"
	167-285	55°	±.00025"
4"	167-297	60°	±.0003"
	167-286	55°	±.0003"
5"	167-298	60°	±.00035"
	167-287	55°	±.00035"
6"	167-299	60°	±.0004"
	167-288	55°	±.0004"

Technical Data

Thread angle: 55° or 60°
Angle Accuracy: ±2°

Standards for V-Anvil Micrometers

SERIES 167

FEATURES

- Specially designed for the zero point setting of V-anvil micrometers.
- Supplied in fitted carton.



SPECIFICATIONS

Metric			
Diameter	Order No.	Type	Accuracy
5mm	167-327	Plug	±2µm
10mm	167-328	Plug	±2µm
25mm	167-329	Plug	±2µm
40mm	167-330	Ring	±3µm
55mm	167-331	Ring	±3µm
70mm	167-332	Ring	±3µm
85mm	167-333	Ring	±3µm

Inch			
Diameter	Order No.	Type	Accuracy
.2"	167-337	Plug	±.0001"
.4"	167-338	Plug	±.0001"
1"	167-339	Plug	±.0001"
1.6"	167-340	Ring	±.00015"
2.2"	167-341	Ring	±.00015"
2.8"	167-342	Ring	±.00015"
3.4"	167-343	Ring	±.00015"

Tool Kits

The Digimatic Tool Kits include Mitutoyo's highly popular 0-1" / 0-25mm Digimatic Micrometer (choose ratchet or friction type) and 0-6" / 0-150mm Digimatic Caliper with Absolute Encoder. The case is made of handsome, solid mahogany and has space for gage batteries. The micrometer spanner is a supplied accessory.

Order No. 64PKA068 (Inch Tool Kit)	
Item No.	Description
103-135	Outside Micrometer (Friction Thimble Type) (Range: 0-1", Graduation: .0001")
505-675	Dial Caliper (Range: 0-6", Dial Graduation: .001")
182-204	6" Full-Flexible Rule (3R)
64PPP932	Mahogany Case



64PKA068

Order No. 64PKA069 (Inch Tool Kit)	
Item No.	Description
103-135	Outside Micrometer (Friction Thimble Type) (Range: 0-1", Graduation: .0001")
182-202	6" Full-Flexible Rule (16R)
513-518T	Test Indicator Set (Range: .04", Graduation: .001")
505-675	675 Dial Caliper (Range: 0-6", Dial Graduation: .001")
050501	Mahogany Case



64PKA069

The very basic measuring instruments recommended for vocational students and machinist apprentices are supplied in this kit.

Order No. 64PKA070 (Inch Tool Kit)	
Item No.	Description
101-117	Outside Micrometer (Friction Thimble Type) (Range: 0-1", Graduation: .0001")
129-132	Depth Micrometer (with 6 pcs Rods) (Range: 0-6", Graduation: .001")
182-202	Full-Flexible Rule (16R)
505-675	Dial Caliper (Range: 0-6", Graduation: .001")
050503	Mahogany Case



64PKA070

For operations where depth measurements are a primary concern, this kit is ideal for measuring depths to 6", in addition to providing the tools for regular precision measurements.

Order No. 64PKA071A (Inch Tool Kit)	
Item No.	Description
103-922	Outside Micrometer Set (3 pcs) (Range: 0-3", Graduation: .0001")
141-208	Inside Micrometer (with 6 pcs Rods)
180-905B	Combination Set (4R)
182-202	Full-Flexible Rule (16R)
513-518T	Test Indicator Set (Range: .04", Graduation: .001")
505-675	Dial Caliper (Range: 0-6", Dial Graduation: .001")
24165	Dial Indicator (Range: 1.0", Graduation: .001")
70105	Magnetic Stand
050504	Mahogany Case



64PKA071A

Most every routine inspection assignment can be completed with the eight high-quality MITUTOYO Precision Measuring Instruments provided in this deluxe kit.

Tool Kits



64PKA080A

Order No. 64PKA080A (Inch Tool Kit)	
Item No.	Description
182-102	6" Steel Rule (16R)
103-177	Micrometer (Ratchet Thimble) (Range 0-1", Graduation .001")
505-717	Dial Caliper (Range: 0-6", Dial Graduation: .001")
64PPP932	Mahogany Case



64PKA073B

Order No. 64PKA073B (Tool Kit Lite)	
Item No.	Description
182-102	6" Steel Rule (16R)
700-113-10	0 - 6" / 0 - 150mm MyCal Lite (Resolution: .001" / 0.1mm)
293-831-30	0 - 1" / 0 - 25.4mm MDC Lite (Ratchet Stop) (Resolution: .00005" / 0.001mm)
64PPP932	Mahogany Case



64PKA076B

Order No. 64PKA076B (Digimatic Tool Kit)	
Item No.	Description
293-340-30	Digimatic Micrometer (Ratchet Stop Type) (Range: 0 - 1" / 0 - 25.4mm, LCD Resolution: .00005" / 0.001mm)
500-196-30	Digimatic Caliper with Absolute Encoder (Range: 0 - 6" / 0 - 150mm, LCD Resolution: .0005" / 0.001mm)
64PPP932	Mahogany Case



64PKA077B

Order No. 64PKA077B (Digimatic Tool Kit)	
Item No.	Description
293-348-30	Digimatic Micrometer (Friction Thimble Type) (Range: 0 - 1" / 0 - 25.4mm, LCD Resolution: .00005" / 0.001mm)
500-196-30	Digimatic Caliper with Absolute Encoder (Range: 0 - 6" / 0 - 150mm, LCD Resolution: .0005" / 0.001mm)
64PPP932	Mahogany Case