

Surftest SJ-210

SERIES 178 — Portable Surface Roughness Tester



Surftest SJ-210



FEATURES

- The 2.4-inch color graphic LCD provides excellent readability and an intuitive display that is easy to use. The LCD also includes a backlight for improved visibility in dark environments.
- The Surftest SJ-210 can be easily operated using the buttons on the front of the unit and under the sliding cover.
- Up to 10 measurement conditions and one measured profile can be stored in the internal memory.
- An optional memory card can be used as an extended memory to store large quantities of measured profiles and conditions.

- Access to each feature can be password-protected, which prevents unintended operations and allows you to protect your settings.
- The display interface supports 16 languages, which can be freely switched.
- An alarm warns you when the cumulative measurement distance exceeds a preset limit.
- The Surftest SJ-210 complies with the following standards: JIS (JIS-B0601-2001, JIS-B0601-1994, JIS B0601-1982), VDA, ISO-1997, and ANSI.
- In addition to calculation results, the Surftest SJ-210 can display sectional calculation results and assessed profiles, load curves, and amplitude distribution curves.

SPECIFICATIONS/CONFIGURATION

Model No.	SJ-210					
Order No. (inch/mm)	178-561-01A	178-561-02A	178-563-01A	178-563-02A	178-565-01A	178-565-02A
Drive unit	Standard type (178-230-2)		Retractable type (178-235)		Transverse tracing type (178-233-2)	
Detector	0.75mN type (178-296)	4mN type (178-390)	0.75mN type (178-296)	4mN type (178-390)	0.75mN type (178-387)	4mN type (178-386)
Display unit	Compact type (178-253A)					
Detector: Tip angle	60°	90°	60°	90°	60°	90°
Stylus tip radius	2μm	5μm	2μm	5μm	2μm	5μm
Detector measuring force	0.75mN	4mN	0.75mN	4mN	0.75mN	4mN
Standard accessories	12BAA303 Connecting cable 178-602 Roughness specimen (Ra 3.00μm) 12BAK699 Carrying case 12BAK700 Calibration stage 12BAK820 Protective sheets for display AC Adapter Operation manual Quick reference manual Warranty			12BAA303 Connecting cable 178-606 Roughness specimen (Ra 1.00μm) 12AAE643 Point-contact adapter 12AAE644 V-type adapter 12BAK699 Carrying case 12BAK700 Calibration stage 12BAK820 Protective sheets for display AC Adapter, Operation manual Quick reference manual, Warranty		

DIMENSIONS Display unit, Drive unit

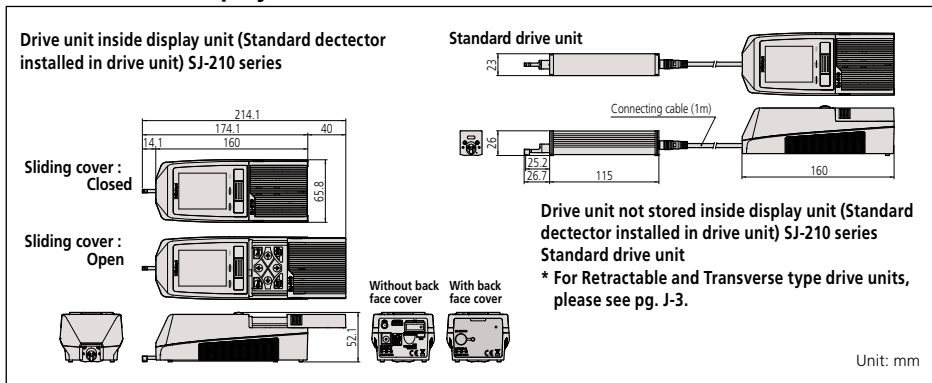

Technical Data: SJ-210

X axis (drive unit)	
Measuring range:	.70" (17.5mm) .22" (5.6mm) Transverse type
Measuring speed:	.01, .02, .03"/s (0.25, 0.5, 0.75mm/s) .039"/s (1mm/s) (Returning)
Detector	
Range:	360μm (-200μm to +160μm)
Measuring method:	skidded
Measuring force:	4mN (0.75mN)
Stylus tip:	Diamond, 90° / 5μmR (60° / 2μmR)
Skid radius of curvature:	40mm
Skid force:	less than 400mN
Type:	Differential inductance
Power supply:	Two-way power supply: battery (rechargeable Ni-MH battery) and AC adapter
Charging time:	about 4 hours (may vary due to ambient temperature)
Endurance:	about 1000 measurements (differs slightly due to use conditions/environment)
External I/O:	USB I/F, Digimatic Output, Printer Output, RS-232C I/F, Foot SW I/F
Data storage:	Memory card (2GB) (option 12AAL069)
Dimensions (WxDxH)	
Display unit:	2.05x2.59x6.3" (52.1 x 65.8 x 160mm)
Drive unit:	6.85x2.59x2" (115 x 23 x 26mm)
Mass:	About 1.1lb (0.5kg) (Display unit + Drive unit + Standard detector)

Evaluation Capability: SJ-210

Applicable standards: JIS'82, JIS'94, JIS'01, ISO'97, ANSI, VDA

Assessed profiles: Primary profile, Roughness profile, DF profile, Roughness profile-Motif

Evaluation parameters: Ra, Rc, Ry, Rz, Rq, Rt, Rmax, Rp, Rv, R3z, Rsk, Rku, Rc, Rpc, Rsm, Rz1max, S, HSC, RzJIS, Rppi, RΔa, RΔq, Rlr, Rmr, Rmr(c), Rdc, Rk, Rpk, Rvk, Mr1, Mr2, A1, A2, Vo, Rpm, tp, Htp, R, Rx, AR, Possible Customize

Analysis graphs: Bearing area curve / Amplitude distribution curve

Digital filters: Gaussian, 2CR75, PC75

Cut off length: λc: .003, .01, .03, .1" (0.08, 0.25, 0.8, 2.5mm)
λs: .1, .3" (2.5, 8μm)

Sampling length: .003, .01, .03, .1" or arbitrary (0.08, 0.25, 0.8, 2.5mm) or arbitrary

Number of sampling lengths (x n): x1, x2, x3, x4, x5, x6, x7, x8, x9, x10 arbitrary length (0.3 to 16.0mm: 0.01mm interval)
x1, x2, x3, x4, x5, x6, x7, x8, x9, x10 arbitrary length (0.3 to 5.6mm: 0.01mm interval)*

* Only for Transverse tracing drive unit type

Function: SJ-210

Customization: Desired parameters can be selected for calculation and display.

Go/no-go judgment: By max value / 16% / Standard dev.

Storage of measurement condition: Save the conditions at power OFF

Storage: Internal memory: Measurement condition (10 sets), Measured profile (1 set)

Memory card (Option): 500 measurement conditions, 10,000 measured profiles, 500 display images

Text file (Measurement conditions / Measured profile / Assessed profile / Bearing area curve / Amplitude distribution curve)

Calibration: Auto-calibration with the entry of numerical value / Average calibration with multiple measurement (Max.5 times) is available

Technical Data: SJ-310

X axis (drive unit)	
Measuring range:	.70" (17.5mm) .22" (5.6mm) Transverse type
Measuring speed:	.01, .02, .03"/s (0.25, 0.5, 0.75mm/s) .039"/s (1mm/s) Returning
Detector	
Range:	360µm (-200µm to +160µm)
Measuring method:	skidded
Measuring force:	4mN (0.75mN)
Stylus tip:	Diamond, 90° / 5µmR (60° / 2µmR)
Skid radius of curvature:	40mm
Skid force:	less than 400mN
Type:	Differential inductance
Power supply:	
	Two-way power supply: battery (rechargeable Ni-MH battery) and AC adapter
Battery	
Charging time:	4 hours maximum
Recharge cycles:	Approximately 1500 times (slightly varies with the usage and environmental conditions)
External I/O:	
	USB I/F, Digimatic Output, RS-232C I/F, External SW I/F
Data storage:	Memory card (8GB) (option 12AAA841)
Dimensions (WxDxH)	
Control unit:	10.8x4.29x7.8" (275 x 109 x 198mm)
Drive unit:	6.85x2.59x2" (115 x 23 x 26mm)
Mass	
Display unit:	Approx. 3.7lb (1.7kg)
Drive unit:	.4lb (0.2kg)

Evaluation Capability: SJ-310

Applicable standards:	
JIS'82, JIS'94, JIS'01, ISO'97, ANSI, VDA	
Assessed profiles:	
P (primary profile), R (roughness profile), DIN4776, roughness motif, waviness motif	
Evaluation parameters:	
Ra, Ry, Rz, Rt, Rp, Rq, Rv, Rsk, Rku, Rc, RSm, S, R _{Pc} , R3z, Rm(c), Rpk, Rvk, R _{dc} , Rk, Mr1, Mr2, Lo, R _{Pp1} , R, AR, Rx, A1, A2, Vo, HSC, Rmr, SK, Ku, R _{Da} , R _{Δq} , Rlr, λa, λq, Rpm, RzJIS (JIS'01), tp (ANSI), Htp (ANSI), Wte, Wx, W, AW, Rz1max (ISO), Rmax (VDA, ANSI, JIS'82), Possible Customize	
Analysis graphs:	
Bearing Area Curve (BAC), Amplitude Distribution Curve (ADC)	
Digital filter:	
2CR, PC75, Gaussian	
Cutoff length:	
λc: .003, .01, .03, .1, .3" (0.08, 0.25, 0.8, 2.5, 8mm) λs: .1, .3" (2.5, 8µm)	
Sampling length:	
.003, .01, .03, .1, .3" or arbitrary (0.08, 0.25, 0.8, 2.5, 8mm) or arbitrary	
Number of sampling lengths (x n):	
x1, x2, x3, x4, x5, x6, x7, x8, x9, x10 arbitrary length (0.3 to 16.0mm: 0.01mm interval)	
x1, x2, x3, x4, x5, x6, x7, x8, x9, x10 arbitrary length (0.3 to 5.6mm: 0.01mm interval)*	
* Only for Transverse tracing drive unit type	
Printer:	
Thermal type	
Printing width:	
48mm (paper width: 58mm)	
Recording magnification:	
Vertical magnification: 10X to 100,000X, Auto	
Horizontal magnification: 1X to 1,000X, Auto	

Function: SJ-310

Customization: Desired parameters can be selected for calculation and display.	
Statistical processing: Maximum value, minimum value, mean value, standard deviation, pass rate, histogram of each parameter	
Go/no-go judgment: maximum value rule, 16% rule, average value rule, standard deviation (1σ, 2σ, 3σ)	
Storage: Internal memory: Measurement condition (10 sets)	
Memory card (Option): 500 measurement conditions, 10,000 measured profiles, 500 display images, Text file (Measurement conditions / Measured profile / Assessed profile / Bearing area curve / Amplitude distribution curve), 500 statistical data, etc.	
Calibration: Auto-calibration with the entry of numerical value / Average calibration with multiple measurement (Max.12 times) is available.	
Power-saving function: Auto-sleep-function, Auto light-off of Backlight by ECO mode.	

Surftest SJ-310

SERIES 178 — Portable Surface Roughness Tester



Surftest SJ-310

FEATURES

- The data processing unit offers large 5.7-inch color graphic LCD touch-panel for superior readability and operability. The LCD also includes a backlight for improved visibility in dark environments.
- The excellent user interface provides intuitive and easy-to-understand operability.

- Complies with the following standards: JIS (JIS-B0601-2001, JIS-B0601-1994, JIS B0601-1982), VDA, ISO- 1997, and ANSI.
- The Measure-Start and other frequently used buttons are strengthened to resist wear and the detrimental effects of workshop contaminants.
- Equipped with a large-capacity battery allowing approximately 1500 measurements when fully charged.
- Includes convenient carrying case for protection in the field.
- A high-speed printer is built into the main unit. Either landscape or portfolio mode can be selected according to the application. Paper saving mode is supported.
- The display interface supports 16 languages, which can be easily switched.
- 10 sets of measurement conditions can be saved in the measurement unit—an optional memory card can save measurement conditions and the measured profile.

SPECIFICATIONS/CONFIGURATION

Model No.	SJ-310					
Order No. (inch/mm)	178-571-01A	178-571-02A	178-573-01A	178-573-02A	178-575-01A	178-575-02A
Drive unit	Standard type (178-230-2)		Retractable type (178-235)		Transverse tracing type (178-233-2)	
Detector	0.75mN type (178-296)	4mN type (178-390)	0.75mN type (178-296)	4mN type (178-390)	0.75mN type (178-387)	4mN type (178-386)
Display unit	Standard type with printer					
Detector: Tip angle	60°	90°	60°	90°	60°	90°
Stylus tip radius	2µm	5µm	2µm	5µm	2µm	5µm
Detector measuring force	0.75mN	4mN	0.75mN	4mN	0.75mN	4mN
Standard accessories	12AAM475 Connecting cable 12AA217 Nosepiece for plane surface 12AAA218 Nosepiece for cylinder 12AAA216 Supporting leg 12BAK700 Calibration stage 12BAG834 Stylus pen 12BAL402 Protection sheet 270732 Printer paper (5 pieces) 12BAL400 Carrying case Roughness reference specimen (Ra3µm), AC adapter, Philips screwdriver, Strap for stylus pen, Operation manual, Quick reference manual, Warranty		12AAM475 Connecting cable 12AAE643 Point-contact adapter 12AAE644 V-type adapter 12BAK700 Calibration stage 12BAG834 Stylus pen 12BAL402 Protection sheet 270732 Printer paper (5 pieces) 12BAL400 Carrying case Roughness reference specimen (Ra1µm), AC adapter, Philips screwdriver, Strap for stylus pen, Operation manual, Quick reference manual, Warranty			

DIMENSIONS Display unit, Drive unit

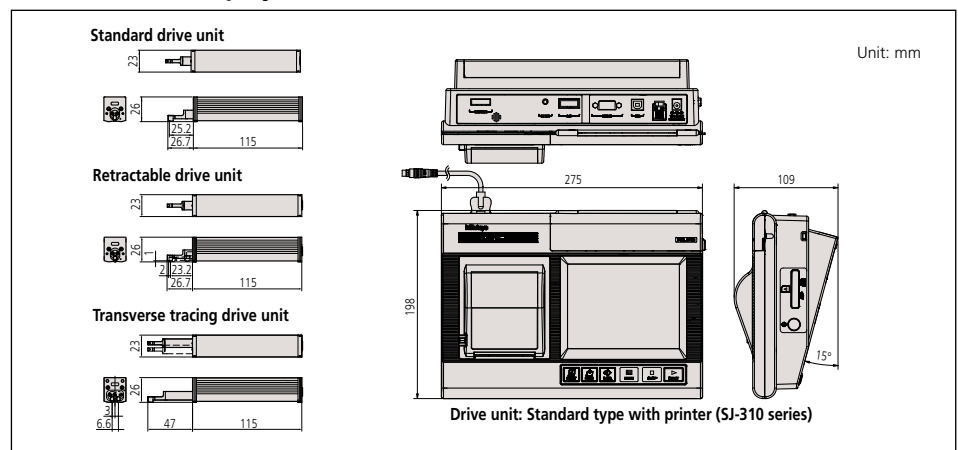

Surftest / SJ-310

SERIES 178 — Optional Accessories

Detectors

Unit: mm

Standard detectors

Order No.	Measuring force	Stylus profiles*	Remarks column
178-296	0.75mN	2 μ mR/60°	Dedicated to the standard/retractable drive unit
178-390	4 mN	5 μ mR/90°	
178-387	0.75mN	2 μ mR/60°	Dedicated to the transverse tracing drive unit
178-386	4 mN	5 μ mR/90°	
178-395	0.75mN	2 μ mR/90°	Dedicated to the standard/retractable drive unit
178-391	4 mN	10 μ mR/90°	

* Tip radius / Tip angles

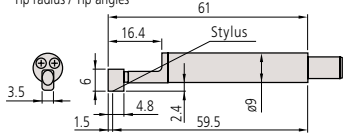

Gear-tooth surface detectors

Order No.	Measuring force	Stylus profiles*
178-388	0.75mN	2 μ mR/60°
178-398	4 mN	5 μ mR/60°

* Tip radius / Tip angles

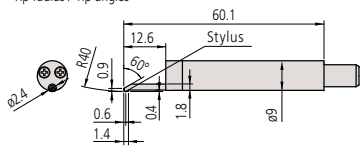

Small hole detectors

Order No.	Measuring force	Stylus profiles*	Remarks column
178-383	0.75mN	2 μ mR/60°	Minimum measurable hole diameter: ϕ 4.5mm
178-392	4 mN	5 μ mR/90°	

* Tip radius / Tip angles

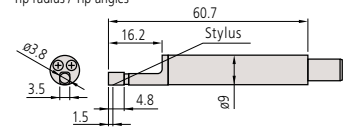

Deep groove detectors

Order No.	Measuring force	Stylus profiles*	Remarks column
178-385	0.75mN	2 μ mR/60°	Not available for the transverse tracing drive unit
178-394	4 mN	5 μ mR/90°	

* Tip radius / Tip angles

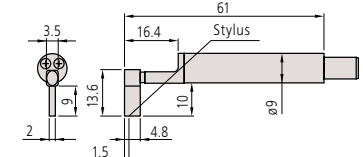

Extra small hole detectors

Order No.	Measuring force	Stylus profiles*	Remarks column
178-384	0.75mN	2 μ mR/60°	Minimum measurable hole diameter: ϕ 2.8mm
178-393	4 mN	5 μ mR/90°	

* Tip radius / Tip angles

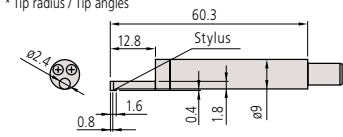

SJ-Printer for SJ-210

Assessed profiles and calculation results and curves can be printed out by connecting the SJ-210-dedicated printer, which is palm sized (WxDxH: 93x125x70mm) and can run on an internal battery.

- Power supply can be selected. (AC adapter or battery pack)
- Printable items: Measurement conditions, calculation results, assessed profile, bearing area curve (BAC), amplitude distribution curve (ADC), and environment settings.



178-421A

*Not compatible with older SJ-201 models.



Example of the connection with SJ-210

Durable Printer paper (25m, 5 rolls/set): **12AAA876**

Printer paper (5 packs): **270732**

RS-232C cable: **12AAL067**

DP-1VR

It is possible to process Digimatic data output from the Surftest SJ series with the DP-1VR. This compact, hand-held device can provide printouts of measurement data and various statistical analyses results such as histograms, D-charts, and Xbar-R control charts. With optional output cables, DP-1VR is also capable of RS-232C output of measurement data to a PC (cable **09EAA084**) and go/no-go condition output (cable **965516**).



264-504-5A

Connecting cable: **936937** 40'' (1m)

Connecting cable: **965014** 80'' (2m)

AC adapter: **09EAA088**

Printer paper: **09EAA082**



Free Communication Software

SJ-Tools

This program can be downloaded for FREE from the Mitutoyo website. <http://www.mitutoyo.com>

Output software based on Microsoft-Excel* for controlling the devices and reproducing and storing the measurement data.

* Microsoft-Excel is not included in the scope of supply. Complete with exclusive accessories.

- Measurement device control
- Definition of measurement variables
- Graphic representation of the profile
- Storage of measurement records
- Documentation of measurement results
- Connecting cable

Optional cables (Required for software communication)

- 12AAL068:** USB PC connecting cable(USB cable)for SJ-210
- 12AAD510:** USB PC connecting cable(USB cable)for SJ-310/410
- 12AAL067:** RS-232C cable for SJ-210
- 12AAA882:** RS-232C cable for SJ-310/410
- 12AAH490:** USB PC connecting cable for SJ-500/SV-2100



SJ-Tools input mask for Surftrac SJ series

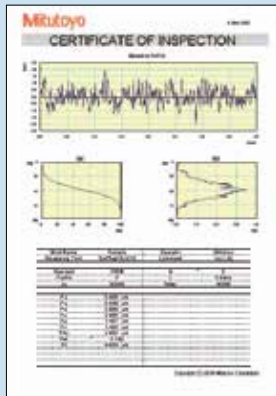

SJ-Tools output record from MS-Excel

Optional Accessories

- 12AAL272:** SJ-210 Replacement Battery Pack
- 12AAN046:** SJ-310 Replacement Battery Pack
- 12BAK820:** SJ-210 Display Protection Sheet (1pc.)
- 12AAL066:** SJ-210 Display Protection Sheet (5pcs.)
- 12BAL402:** SJ-310 Display Protection Sheet (1pc.)
- 12AAN040:** SJ-310 Display Protection Sheet (10pcs.)
- 178-601:** Precision Reference Specimen (Ra 3.00 μm)
- 178-602:** Precision Reference Specimen (Ra 119 μm / 3.00 μm)
- 178-603:** Precision Reference Specimen – 2 values (GAR)
- 178-604:** Precision Reference Specimen – 2 Values (MIT)
- 178-606:** Precision Reference Specimen for Transverse Drive (Ra 0.039 μm / 1.0 μm)
- 178-029:** Manual Column Stand, must use adapter 12AAA221 to mount SJ drive unit.

Nosepiece, Adapter

Nosepiece for flat surfaces

12AAA217

- SJ-210/210R optional accessory.
- SJ-310/310R standard accessory.
- Not available for the transverse tracing drive unit.

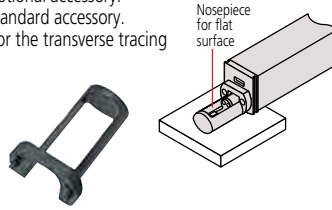

V-type adapter

12AAE644

- SJ-210/SJ-310 Transverse tracing type standard accessory.
- Dedicated to the transverse tracing drive unit.

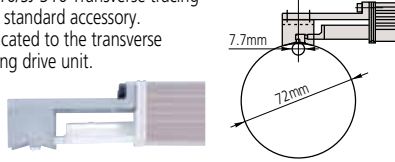

Extension rod (50mm)

12AAA210

- Not available for the transverse tracing drive unit.

(Note: Only one rod can be used.)

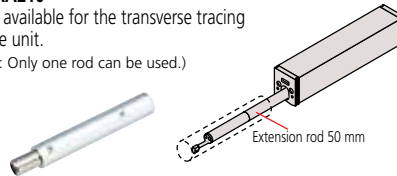

Magnetic stand adapter

12AAA221 (ø8mm)

12AAA220 (ø9.5mm)

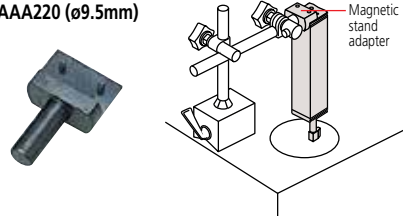

Extension cable (1m)

12BAA303

- Only one cable can be used.

Nosepiece for cylindrical surfaces

12AAA218

- SJ-210/210R optional accessory.
- SJ-310/310R standard accessory.
- Not available for the transverse tracing drive unit.
- ø30mm or smaller workpiece

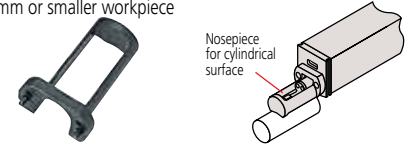

Point-contact adapter

12AAE643

- SJ-210/SJ-310 Transverse tracing type standard accessory.
- Dedicated to the transverse tracing drive unit.

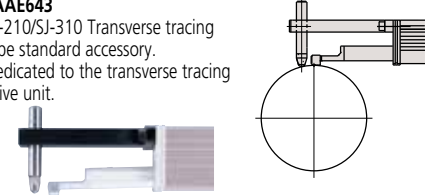

Support feet set

12AAA216

- SJ-210/210R optional accessory.
- SJ-310/310R standard accessory.
- Not available for the detector side of the transverse tracing drive unit.

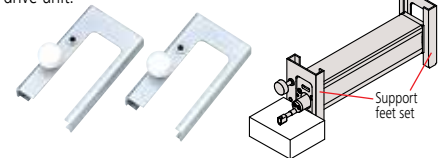

Vertical positioning adapter

12AAA219

- Not available for the transverse tracing drive unit.

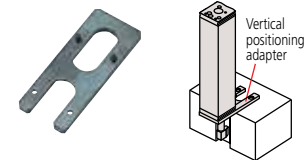

Height gage adapter

12AAA222 (9mm x 9mm)

12AAA233 (1/4" x 1/2")

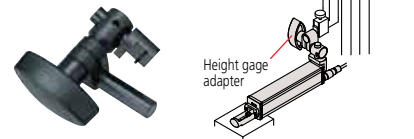

Setting attachments

* Not available for the transverse tracing drive unit

Improves measurement efficiency by allowing the setup of workpieces of the same type and the positioning of hard-to-access features of a workpiece.

No. 178-033

V-type for measuring in the cylinder axis direction



The V-width is adjustable to the cylinder diameter facilitating axial measurement of a wide range of cylinder diameters.

- Adjustable range: ø 5 - 150mm

No. 178-034

Setting attachment: Magnetic slider type



Best suited for measurement of the flat surface of a workpiece that has partial indentations and steps and that is hard to set the drive unit. Combination use with the magnet type specimen holder (Option No. 12AAA910) further improves the ease of operation.

No. 178-035

Setting attachment: Inside diameter type



Greatly facilitates measurement of internal wall surfaces of, for example, cylinder-block bores.

- Applicable diameter: ø75 - ø95mm
- Accessible depth: 30 - 135mm

Surftest SJ-410

SERIES 178 — Portable Surface Roughness Tester

FEATURES

- Both skidded and skidless measurement are possible with this series. Equipped with 46 roughness parameters that conform to the latest ISO, DIN, ANSI, and JIS standards.
- A wide-range, high-resolution detector and a drive unit provide superior high-accuracy measurement in its class.

Detector

Measuring range: 800µm
Resolution: 0.000125µm (at 8µm range)

Drive unit

Straightness/traverse length
SJ-411: 0.3µm/25mm
SJ-412: 0.5µm/50mm



- A skidless detector and a curved surface compensation function provide efficient evaluation of cylinder surface roughness.

Skidless measurement

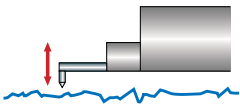

Surftest SJ-411

SPECIFICATIONS

Model No.	SJ-411	SJ-411	SJ-412	SJ-412
Order No. (inch/mm)	178-581-01A	178-581-02A	178-583-01A	178-583-02A
Detector measuring force	0.75mN	4mN	0.75mN	4mN
Evaluation range	25mm	25mm	50mm	50mm
Stylus tip	Tip angle	60°	90°	60°
	Tip radius	2µm	5µm	2µm

- Ultra-fine steps, straightness and waviness can be measured by using the skidless measurement function.
- The handheld data processing unit and the 5.7-inch color graphic LCD touch-panel provides superior readability and operability. The LCD also includes a backlight for improved visibility in dark environments.
- The excellent user interface provides intuitive and easy-to-understand operability.
- Measured data can be output to a PC with optional RS-232C or USB cable.
- Digital filter function for non-distorted roughness profiles.
- Go/no-go judgment function.
- Auto-calibration function.
- The display interface supports 16 languages, which can be freely switched.
- Simplified contour analysis function supports the four types of measurement: step, level change, area and coordinate difference.
- Access to each feature can be password-protected, which prevents unintended operations and allows you to protect your settings.
- The optional attachments for mounting on a column stand significantly increase the operability.

Technical Data: X axis (drive unit)

Measuring range:	1" (25mm) (SJ-411), 2" (50mm) (SJ-412)
Measuring speed:	.002, .004, .008, .02, .04"/s (0.05, 0.1, 0.5, 1.0mm/s)
Return speed:	.02, .04, .08"/s (0.5, 1.0, 2.0mm/s)
Traversing direction:	Backward
Traverse linearity:	12 µin / 1" (0.3µm/25mm) (SJ-411), 20 µin / 2" (0.5µm/50mm) (SJ-412)
Positioning:	±1.5° (tilting), 10mm (up/down)
Detector Range / resolution:	800µm / 0.0125µm, 80µm / 0.00125µm, 8µm / 0.000125µm (up to 2400µm with an optional stylus)
Measurement method:	Skidless / skidded
Measuring force:	0.75mN (4mN)
Stylus tip:	Diamond, 60° / 2µmR (90° / 5µmR)
Skid radius of curvature:	40mm
Type:	Differential inductance
Power supply:	Via AC adapter / rechargeable battery
Battery life:	Max. app. 1000 measurements (w/o printing)
Recharge time:	4 hours Data output Via USB interface / RS-232C interface / SPC output
Storage: Internal memory:	Measurement condition (10 sets)
Memory card (Option):	500 measurement conditions, 10,000 measured profiles, 500 display images, Text file (Measurement conditions / Measured profile / Assessed profile / Bearing area curve / Amplitude distribution curve), 500 statistical data, etc.
Dimensions (WxDxH)	
Display unit:	10.8x4.3x7.8" (275x109 x198mm)
Height-tilt adjustment unit:	5.16x2.48x3.9" (131x63x99mm)
Drive unit:	5.04x1.41x1.83" (128x36x47mm) (SJ-411), 6.1x1.41x1.83" (155x36x47mm) (SJ-412)
Mass Control unit:	Approx. 3.75lb (1.7kg)
Height-tilt adjustment unit:	Approx. .9lb (0.4kg)
Drive unit:	1.3lb(0.6kg) (SJ-411), 1.5lb(0.7kg)(SJ-412)

Evaluation Capability

Applicable standards:	JIS'82, JIS'94, JIS'01, ISO'97, ANSI, VDA, Free
Assessed profiles:	P (primary profile), R (roughness profile), DF (DF profile), W (filtered waviness profile), roughness motif, waviness motif
Evaluation parameters:	Ra, Rq, Rz, Ry, Rp, Rv, Rt, R3z, Rsk, Rku, Rc, Rpc, RSm, Rmax(VDA, ANSI), Rz1max(ISO'97), S, HSC, RzJIS(JIS'01), Rppi, RΔa, RΔq, Rlr, Rmr, Rmr(c), Rδc, Rk, Rpk, Rvk, Mr1, Mr2, A1, A2, Vo, λq, Lo, Rpm, tp(ANSI), Htp(ANSI), R, Rx, AR, W, AW, Wx, Wte
Analysis graphs:	Bearing Area Curve (BAC), Amplitude Distribution Curve (ADC)
Digital filter:	2CR, PC75, Gaussian
Cutoff length:	λc: .003, .01, .03, .1, .3" (0.08, 0.25, 0.8, 2.5, 8mm) λs: 100, 320, 1000µin (2.5, 8, 25µm) (Availability of switching depends of the selected standard.)
Sampling length:	0.08, 0.25, 0.8, 2.5, 8, 25*mm; or arbitrary length in range 0.1 to 25mm (0.1 to 50mm: SJ-412) in 0.01mm increments
Number of sampling lengths:	1, 2, 3, ~20 (limited by traverse range)
Printer:	Thermal type
Printing width:	48mm (paper width: 58mm)
Recording magnification	
Vertical magnification:	10X to 100,000X, Auto
Horizontal magnification:	1X to 1,000X, Auto
Function	
Customize:	Selection of display/evaluation parameter
Data compensation:	R-surface, Tilt compensation
Ruler function:	Step, level change, area and coordinate difference
D.A.T. function:	Helps to level workpiece prior to skidless measurement displacement detection mode enables the stylus displacement to be input while the drive unit is stopped.
Statistical processing:	Max. value, Min. value, Mean value, Standard deviation (s), Pass ratio, Histogram
GO/NG judgement:	Maximum value rule, 16% rule, average value rule, standard deviation (1σ, 2σ, 3σ)
Calibration:	Auto-calibration with the entry of numerical value /average calibration with multiple measurement (Max.12 times) is available.
Power saving function:	Auto-sleep-function, Auto light-off of Backlight by ECO mode.

* Only for SJ-412

Surftest SJ-410

SERIES 178 — Portable Surface Roughness Tester

DIMENSIONS

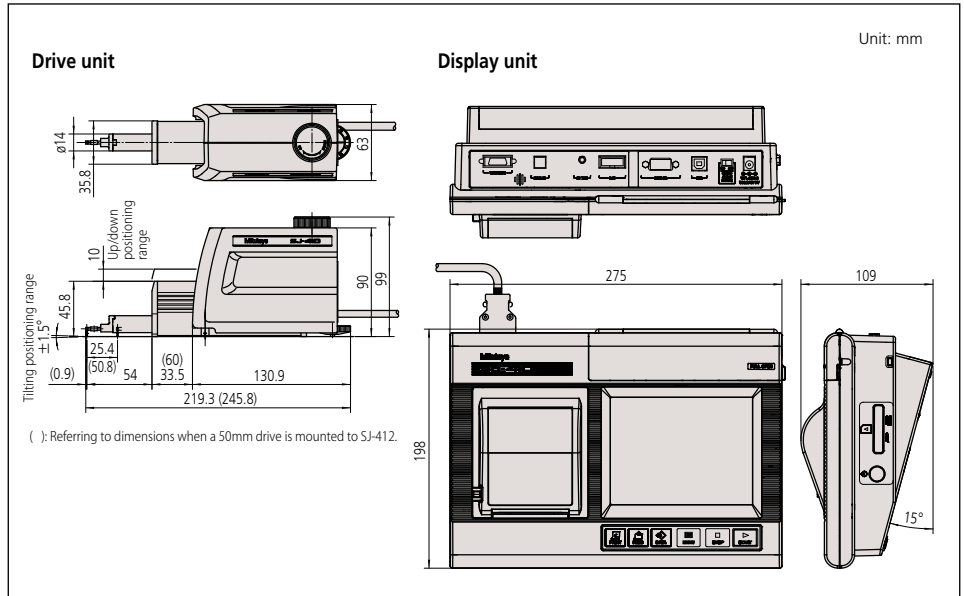

Free Communication Software SJ-Tools

This program can be downloaded for FREE from the Mitutoyo website. <http://www.mitutoyo.com>

Output software based on Microsoft-Excel* for controlling the devices and reproducing and storing the measurement data.

*Microsoft-Excel is not included in the scope of supply.

Complete with exclusive accessories.

- Measurement device control
- Definition of measurement variables
- Graphic representation of the profile
- Storage of measurement results
- Documentation of measurement results

Optional cables (Required for software communication)

- 12AAD510:** USB PC connecting cable (USB cable)
- 12AAA882:** RS-232C connecting cable

Optional Accessories

- 178-611:** Step gage (2 μ m, 10 μ m)
- 178-612:** Step gage (2 μ m, 10 μ m, 79 μ m, 394 μ m)
- 178-610:** Step gage (step: 1 μ m, 2 μ m, 5 μ m, 10 μ m)
- 12AAM556:** Height/tilt adjustment unit for SJ-410
- 178-039:** Manual column stand (granite base) (vertical travel: 250mm)
- 178-010:** Auto-set unit for **178-039**
- 178-020:** X axis adjustment unit for **178-039**
- 178-030:** Tilting adjustment unit (Inclination adjustment unit) for **178-039**
- 12AAB358:** Cylindrical surface adapter (workpiece dia.: 15 - 60mm)
- 178-016:** Leveling table (tilting: $\pm 1.5^\circ$, max. loading: 15kg)
- 178-048:** Leveling table with D.A.T function (mm) (tilting: $\pm 1.5^\circ$, max. loading: 15kg)
- 178-058:** Leveling table with D.A.T function (inch) (tilting: $\pm 1.5^\circ$, max. loading: 15kg)
- 178-043-1:** XY leveling table (25 x 25mm) (tilting: $\pm 1.5^\circ$, max. loading: 15kg, swiveling: $\pm 3^\circ$)
- 178-053-1:** XY leveling table (1" x 1") (tilting: $\pm 1.5^\circ$, max. loading: 15kg, swiveling: $\pm 3^\circ$)
- 178-042-1:** Digital XY leveling table (25 x 25mm) (tilting: $\pm 1.5^\circ$, max. loading: 15kg, swiveling: $\pm 3^\circ$)
- 178-052-1:** Digital XY leveling table (1" x 1") (tilting: $\pm 1.5^\circ$, max. loading: 15kg, swiveling: $\pm 3^\circ$)
- 178-049:** Digital XY leveling table (25 x 25mm) (max. loading: 15kg)
- 178-059:** Digimatic XY leveling table (1" x 1") (max. loading: 15kg)
- 178-019:** Precision vise for XY leveling table (jaw opening: 36mm)
- 998291:** Precision V-block for XY leveling table (workpiece dia.: 1 - 160mm)
- 12AAA841:** Memory card (8GB)
- 965014:** SPC cable (2m)
- 264-012-10:** Input tool (USB type)
- 264-504-5A:** DP-1VR
- : Detectors, Styli, and nosepieces (See pg. J-22/23.)

Consumables

- 12AAN040:** LCD protective sheet (10 sheets/set)
- 12AAA876:** Durable printer paper (25m, 5 rolls/set)
- 270732:** Printer paper (5 pack)
- 12AAN046:** Replacement battery
- 12AAJ088:** Footswitch

MEASUREMENT APPLICATIONS

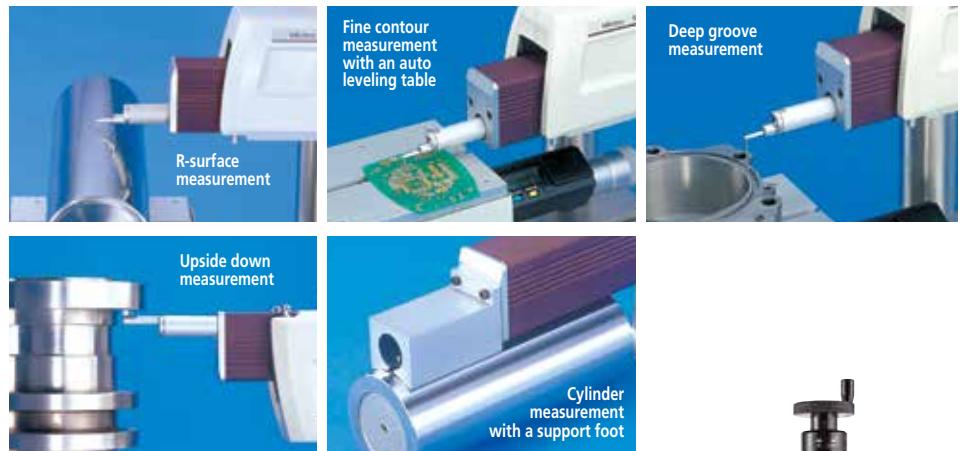

Carrying case is a standard accessory.



Manual column stand
178-039

With optional accessories.

- 178-010:** Auto-set unit
- 178-020:** X-axis adjustment unit
- 178-030:** Tilting adjustment unit

Surftest SJ-500/P, SV-2100

SERIES 178 — with Dedicated Control / PC System / Display Unit

High-precision and high-performance surface roughness tester with a dedicated control unit, achieving user-friendly display and simple operation.

FEATURES

- User-friendly display and simple operation equipped with a highly visible color 7.5-inch TFT LCD.
- Easy positioning. A joy stick built in the dedicated control unit allows easy and quick positioning. Fine positioning of a small stylus, required for measuring the inner side of a small hole, easily can be made using the manual knob.
- Easy setting of measuring conditions for surface roughness. Equipped with simple input function allows inputs according to drawing instruction symbols of ISO/JIS roughness standards. Troublesome measuring condition settings can be easily input by directly selecting a drawing instruction symbol for surface roughness from the menu.



SJ-500

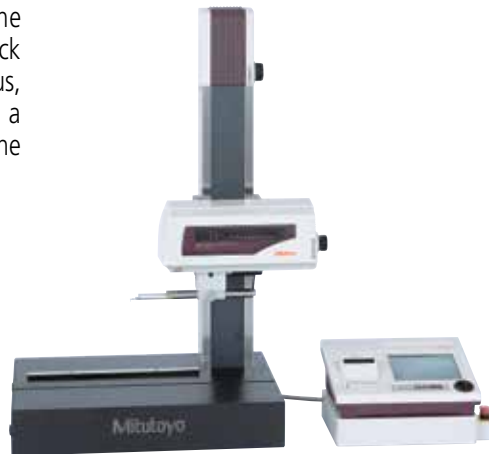

SV-2100S4



SJ-500P

SURFPAK-EZ: Easy-to-use task-focused software

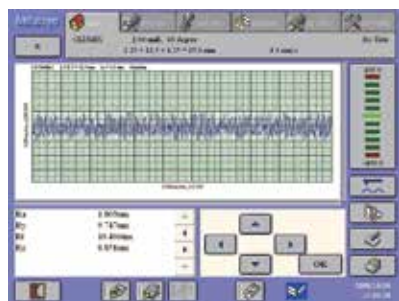

Measurement and results display screen

User-friendly graphical display and button layout allows intuitive operation. Simplified fine-contour analysis provided as standard, including step, area, angle, and circle calculation.

Technical Data: SJ-500

X-axis (drive unit)	
Measuring range:	1.97" (50mm)
Resolution:	1.97µin (0.05µm)
Measurement method:	Linear encoder
Drive speed:	0 - .78"/s (0 - 20mm/s)
Measuring speed:	.00078 - .2"/s (0.02 - 5mm/s)
Traversing direction:	Backward
Traverse linearity:	.0078µin/1.97" (0.2µm / 50mm)
Positioning:	±1.5° (tilting, with DAT function) 1.18" (30mm) (up/down)
Detector	
Resolution / Range:	.4µin/32000µin, .04µin/3200µin, .004µin/320µin 0.01µm (800µm), 0.001µm (80µm), 0.0001µm (8µm)
Detecting method:	Skidless / skid measurement
Measuring force:	4mN (0.75mN) (low force type)
Stylus tip:	Diamond, 90° / 5µmR (60° / 2µmR: low force type)
Skid radius of curvature:	1.57" (40mm)
Detecting method:	Differential inductance
Control unit	
Display:	7.5" color TFT with backlight
Printer:	Built-in thermal printer
Magnification:	Horizontal: X10 to X500,000, Auto Vertical: X0.5 to X10,000, Auto
Drive unit control:	Joystick operation with manual knob

Technical Data: SV-2100

X-axis (drive unit)	
Measuring range:	3.94" (100mm)
Resolution:	1.97µin (0.05µm)
Measurement method:	Linear encoder
Drive speed:	0 - 1.57"/s (0 - 40mm/s)
Measuring speed:	.00078 - .197"/s (0.02 - 5mm/s)
Traversing direction:	Pull
Traverse linearity:	6µin/4" (0.15µm / 100mm)
Z2-axis (column)	
Type:	Manual operation or power drive
Vertical travel:	13.8" or 21.6" (350mm or 550mm*)
Resolution*:	1µm
Measurement method*:	Rotary encoder
Drive speed*:	0 - .78"/s (0 - 20mm/s)
*Only for power-drive type	
Detector	
Resolution / Range :	.4µin/32000µin, .04µin/3200µin, .004µin/320µin 0.01µm / 800µm , 0.001µm / 80µm, 0.0001µm / 8µm
Detecting method:	Skidless / skid measurement
Measuring force:	4mN or 0.75mN (low force type)
Stylus tip:	Diamond, 90° / 5µmR (60° / 2µmR: low force type)
Skid radius of curvature:	1.57" (40mm)
Detecting method:	Differential inductance
Control unit	
Display:	7.5" color TFT with backlight
Printer:	Built-in thermal printer
Magnification:	Horizontal: X10 to X500,000, Auto Vertical: X0.5 to X10,000, Auto
Drive unit control:	Joystick operation with manual knob

Evaluation Capability

Cutoff length	
Is:	0.25µm, 0.8µm, 2.5µm, 8µm, 25µm, 250µm, no filter
Ic*:	0.025mm, 0.08mm, 0.25mm, 0.8mm, 2.5mm, 8mm, 25mm
If:	0.08mm, 0.25mm, 0.8mm, 2.5mm, 8mm, 25mm, no filter
Sampling length (L)*	
	0.025mm, 0.08mm, 0.25mm, 0.8mm, 2.5mm, 8mm, 25mm, 80mm (SV-2100 only)
Data compensation functions	
	Parabola compensation, hyperbola compensation, ellipse compensation, R-plane (curved surface) compensation, conic compensation, tilt compensation

*Arbitrary length can be specified in the range from 0.02mm to 50mm.

- 12AAA876:** High durable printer paper (5 Rolls/set)
- 270732:** Standard type printer paper (5pcs.)

Surftest SJ-500/P, SV-2100

SERIES 178 — with Dedicated Control / PC System / Display Unit

SPECIFICATIONS

Model no.	SJ-500P	SJ-500	SV-2100M4	SV-2100S4	SV-2100H4	SV-2100W4
Type of Data processing	PC System	Dedicated Data Processor	Dedicated Data Processor			
Order No. (inch)	178-531-02A	178-533-02A	178-637-01A	178-681-01A	178-683-01A	178-685-01A
Measuring force of detector	4mN	4mN	0.75mN			
X-axis measuring range	2" (50mm)		4" (100mm)			
Vertical travel	Optional stand		13.8" (350mm) manual column	13.8" (350mm) power column	21.6" (550mm) power column	
Granite base size (WxD)	Optional stand		23.6 x 17.7" (600 x 450mm)			39.4 x 17.7" (1000 x 450mm)
PC I/F Unit	13.7 x 10.4 x 3.4" (350 x 263 x 86mm)	NA	NA	NA	NA	NA
Dimensions (main unit, WxDxH)	16.7 x 3.7 x 6.3" (425 x 94 x 160mm)		28.2 x 17.7 x 34" (716 x 450 x 863mm)	28.2 x 17.7 x 38" (716 x 450 x 966mm)	28.2 x 17.7 x 46" (716 x 450 x 1166mm)	44 x 17.7 x 46.3" (1116 x 450 x 1176mm)
Main unit Mass	5.9 lbs. (2.7 kg)		308.6 lbs. (140 kg)	308.6 lbs. (140 kg)	330 lbs. (150 kg)	485 lbs (220 kg)
Assessed profiles	Dedicated data processor type: P (primary profile), R (roughness profile), WC, envelope residual profile, roughness motif, waviness motif PC system type: P (primary profile), R (roughness profile), WC, WCA, WE, WEA, DIN4776 profile, E (envelope residual profile), roughness motif, waviness motif					
Evaluation parameters	Dedicated data processor type: Ra, Rc, Ry, Rz, Rq, Rt, Rmax, Rp, Rv, R3z, Sm, S, Pc, mr (c), δc, mr, tp, Htp, Lo, lr, Ppi, HSC, Δa, Δq, Ku, Sk, Rpk, Rvk, Rk, Mr1, Mr2, A1, A2, Vo, λa, λq, R, AR, Rx, W, AW, Wx, Wte, (43 parameters), Customization PC system type: Pa, Pq, Psk, Pku, Pp, Pv, Pz, Pt, Pc, PSm, PΔq, Pmr (c), Pmr, Pδc, Ra, Rq, Rsk, Rku, Rp, Rv, Rz, Rt, Rc, RSm, RΔq, Rmr (c), Rmr, Rδc, Wa, Wq, Wsk, Wku, Wp, Wv, Wz, Wt, Wc, WSm, WΔq, Wmr (c), Wmr, Wδc, Rk, Rpk, Rvk, Mr1, Mr2, A1, A2, Rx, AR, R, Wx, AW, W, Wte, Ry, RyDIN, RzDIN, R3y, R3z, S, HSC, Lo, lr, Δa, λa, λq, Vo, Htp, NR, NCRX, CPM, SR, SAR, NW, SW, SAW					
Analysis graphs	Dedicated data processor type: ADC, BAC, power spectrum graph PC system type: ADC, BAC Graph, power spectrum graph, auto-correlation graph, Walsh power spectrum graph, Walsh auto-correlation graph, slope distribution graph, local peak distribution graph, parameter distribution graph					
Curved surface compensation	Dedicated data processor type: Parabolic compensation, Hyperbolic compensation, Elliptical compensation, Circular compensation Conic compensation, Inclination (Entire, Arbitrary) PC system type: Parabolic compensation, Hyperbolic compensation, Elliptical compensation, Circular compensation, Conic compensation, Inclination (Entire, Arbitrary), Polynomial compensation					
Contour analysis	Dedicated data processor type: Area, Circle, Angle, Coordinate difference, Step, Inclination PC system type (SURFPAK-EZ): Area, Circle, Angle, Coordinate difference, Step, Inclination					
Filters	Dedicated data processor type: 2CR-75%, 2CRPC-75%, Gaussian, Robust-spline PC system type: 2CR-75%, 2CR-50%, 2CRPC-75%, 2CRPC-50%, Gaussian, Robust-spline					

Manual column stand options: 178-085 and 178-089 (for SJ-500)

Suitable for desktop use in inspection rooms and such.



No.178-085* Does not include measuring unit
Vertical adjustment range: 11.8" (300mm)
Dimension (W x D x H): 23.6" x 17.7" x 28" (600 x 450 x 710mm)
Weight: 242 lbs (110kg)
No.178-089* Does not include measuring unit
Vertical adjustment range: 9.8" (250mm)
Dimension (W x D x H): 15.7 x 9.8 x 2.4" (400 x 250 x 60mm)
Weight: 44 lbs (20kg)

Dimensions of SJ-500 w/ manual column stand 178-085

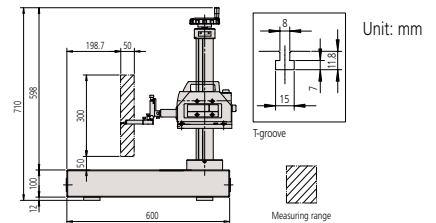

Auto-leveling table: 178-081 (for SJ-500 / SV-2100M4), 178-083 (for SV-2100S4 / H4 / W4)



This is a stage that performs fully automatic leveling as measurement starts, freeing the user from this tedious operation. Fully automatic leveling can be done quickly by anyone. In addition, the operation is easy and reliable.

Inclination adjustment angle	±2°
Maximum load	15.4 lbs (7kg)
Table dimensions	5.12 x 3.94" (130x100mm)
Mass	7.7lbs (3.5kg)



Surftest SV-3200

SERIES 178 — Surface Roughness Testers



SV-3200L4 (with options)



*Shown with optional accessories.

MiCAT
Mitutoyo Intelligent Computer Aided Technology
the standard in world metrology software
FORM

The Surftest SV-3200 Series provide high-accuracy, high-level analysis and multi-functionality in measurement of surface roughness.

FEATURES

- Mitutoyo's Surftest SV-3200 Series provides high-accuracy, high-level analysis and multi-functionality in three-dimensional analysis and measurement of fine contour, as well as the conventional type surface roughness measurement.
- Peripheral devices such as the auto-leveling table are available to enhance operability and to enable automatic measurement.
- FORMTRACEPAK V5, dedicated data-analyzing software, is installed. This software allows data management in a consistent format, from the work site to the laboratory.
- Ceramic, which is known for its superb anti-abrasive property, is used as the X-axis drive unit guide. No lubrication of the guide is required.
- High-accuracy glass scales are built-in on X-axis (resolution: 1.97 μ m (0.05 μ m) and Z2-axis (column, resolution: 39.4 μ m (1 μ m) to ensure high-accuracy positioning.

The SV-3200 series manifest high-reliability especially in the horizontal roughness parameters (S, Sm), that require high-accuracy of the X-axis travel.

- When equipped with high accuracy Y-axis table and 3D surface analysis software MCubeMap, this offers CNC type capabilities usually performed on Extreme series machines.
- Various optional detector holders such as Crank Rotary type and Manual Rotary type make this versatile for many different applications.
- New optional Digital Automatic Tilt (DAT) function is best suited for workpieces that are too large for leveling tables.

Technical Data

X-axis	
Measuring range:	4" or 8" (100mm or 200mm)
Resolution:	1.97 μ m (0.05 μ m)
Measurement method:	Linear encoder
Drive speed:	0 - 3.1"/s (0 - 80mm/s)
Measuring speed:	.00078 - .78"/s (0.2 - 20mm/s)**
Traversing direction:	Backward
Traverse linearity:	4": (2+L) μ m (0.05+0.001L) μ m* 8": 20 μ m / 8" (0.5 μ m/200mm)
Z2-axis (column)	
Vertical travel:	12", 20" or 27.6" (300mm, 500mm or 700mm) power drive
Resolution:	39.4 μ m (1 μ m)
Measurement method:	ABSOLUTE linear encoder
Drive speed:	0 - 1.2"/s (0 - 30mm/s)
Detector	
Range / resolution:	32000 μ m / .4 μ m, 3200 μ m / .04 μ m, 320 μ m / .004 μ m (up to 96000 μ m with an optional stylus) {800 μ m / 0.01 μ m, 80 μ m / 0.001 μ m, 8 μ m / 0.0001 μ m) (up to 2400 μ m with an optional stylus)}
Detecting method:	Skidless / skid measurement
Measuring force:	0.75mN (low force type)
Stylus tip:	Diamond, 60°/2 μ mR (low-force type)
Skid radius of curvature:	1.57" (40mm)
Detecting method:	Differential inductance
Base size (W x H):	23.6 x 17.7" (600 x 450mm) or 39.4 x 17.7" (1000 x 450mm)
Base material:	Granite

*L = Measured length inch (mm)

**Recommended speed: under 5mm/s

If using higher speed, stylus tip may be chipped and/or accuracy may be worse, depending on surface condition.

Evaluation Capability: FORMTRACEPAK V5

Assessed profiles

P (primary profile), R (roughness profile), WC, WCA, WE, WEA, DIN4776 profile, envelope residual profile, roughness motif, waviness motif

Evaluation parameters

Ra, Rq, Rz, Ry, Rz(JIS), Ry(DIN), Rc, Rp, Rpmax, Rpi, Rv, Rvmax, Rvi, Rt, Rti, R3z, R3zi, R3y, S, Pc (Ppi), Sm, HSC, mr, δ c, plateau ratio, mrd, Rk, Rpk, Rvk, Mr1, Mr2, Δ a, Δ q, λ a, λ q, Sk, Ku, Lo, Lr, A1, A2

Roughness motif parameters: Rx, R, AR, SR, SAR, NR, NCRX, CPM

Waviness motif parameters: Wte, Wx, W, AW SW, SAW, NW

Analysis graphs

ADC, BAC1, BAC2, power spectrum chart, auto-correlation chart, Walsh power spectrum chart, Walsh auto-correlation chart, slope distribution chart, local peak distribution chart, parameter distribution chart

Digital filter 2CR-75%, 2CR-50%, 2CR-75% (phase corrected), 2CR-50% (phase corrected), Gaussian-50%

Cutoff length*

λ c: .001, .003, .01, .03, .1, .3, 1"
(0.025mm, 0.08mm, 0.25mm, 0.8mm, 2.5mm, 8mm, 25mm)

fl: .001, .003, .01, .03, .1, .3, 1"
(0.08mm, 0.25mm, 0.8mm, 2.5mm, 8mm, 25mm)

fh: .001, .003, .01, .03, .1, .3, 1"
(0.08mm, 0.25mm, 0.8mm, 2.5mm, 8mm)

Sampling length (L)*.001, .003, .01, .03, .1, .3, 1"
(0.025mm, 0.08mm, 0.25mm, 0.8mm, 2.5mm, 8mm, 25mm)

Data compensation functions

Tilt compensation, R-plane (curved surface) compensation, ellipse compensation, parabola compensation, hyperbola compensation, quadric curve automatic compensation, polynomial compensation, polynomial automatic compensation

*Arbitrary length can be specified in the range from .001" (0.025mm) to the maximum traverse length.

Surftest SV-3200

SERIES 178 — Surface Roughness Testers

SPECIFICATIONS

 Models without X-axis inclination function

Model No.	SV-3200S4	SV-3200H4	SV-3200W4	SV-3200L4
Order No. (inch)	178-424-11A	178-425-11A	178-426-11A	178-464-11A
Order No. (mm)	178-444-11A	178-445-11A	178-446-11A	178-484-11A
Measuring force of detector	0.75mN	0.75mN	0.75mN	0.75mN
X-axis measuring range	4" (100mm)	4" (100mm)	4" (100mm)	4" (100mm)
Vertical travel	12" (300mm) power column	20" (500mm) power column	20" (500mm) power column	27.6" (700mm) power column
Granite base size (WxD)	23.6 x 17.7" (600 x 450mm)	23.6 x 17.7" (600 x 450mm)	39.4 x 17.7" (1000 x 450mm)	39.4 x 17.7" (1000 x 450mm)
Dimensions (main unit, WxDxH)	29.8 x 19.0 x 38.0" (756 x 482 x 966mm)	29.8 x 19.0 x 45.9" (756 x 482 x 1166mm)	45.5 x 19.0 x 46.3" (1156 x 482 x 1176mm)	45.5 x 19.0 x 56.5" (1156 x 482 x 1436mm)
Mass (main unit)	308 lbs (140kg)	330 lbs (150kg)	485 lbs (220kg)	595 lbs (270kg)

Model No.	SV-3200S8	SV-3200H8	SV-3200W8	SV-3200L8
Order No. (inch)	178-427-11A	178-428-11A	178-429-11A	178-465-11A
Order No. (mm)	178-447-11A	178-448-11A	178-449-11A	178-485-11A
Measuring force of detector	0.75mN	0.75mN	0.75mN	0.75mN
X-axis measuring range	8" (200mm)	8" (200mm)	8" (200mm)	8" (200mm)
Vertical travel	12" (300mm) power column	20" (500mm) power column	20" (500mm) power column	27.6" (700mm) power column
Granite base size (WxD)	23.6 x 17.7" (600 x 450mm)	23.6 x 17.7" (600 x 450mm)	39.4 x 17.7" (1000 x 450mm)	39.4 x 17.7" (1000 x 450mm)
Dimensions (main unit, WxDxH)	30.2 x 19.0 x 38.0" (766 x 482 x 966mm)	30.2 x 19.0 x 45.9" (766 x 482 x 1166mm)	45.9 x 19.0 x 46.3" (1166 x 482 x 1176mm)	45.5 x 19.0 x 56.5" (1156 x 482 x 1436mm)
Mass (main unit)	308 lbs (140kg)	330 lbs (150kg)	485 lbs (220kg)	595 lbs (270kg)

Optional Accessories

- 178-602-1:** Reference Specimen (Supports ISO)
 - 178-611:** Reference Step Specimen (2µm, 10µm)
 - 178-612:** Reference Step Specimen (2µm, 10µm, 79µin, 394µin)
 - 178-610:** Step gage (1µm, 2µm, 5µm, 10µm)
 - 178-047:** Three-axis adjustment table (including 998291 precision V-block.)
 - 178-016:** Leveling table
 - 178-042-1:** Digimatic XY leveling table (25 x 25mm)
 - 178-052-1:** Digimatic XY leveling table (1 x 1")
 - 178-043-1:** XY leveling table (25 x 25mm)
 - 178-053-1:** XY leveling table (1 x 1")
 - 178-019:** Precision vise*
 - 998291:** Precision V-block*
 - 181-902-10:** V-block set with clamp (Max. workpiece dia.: 25mm)
 - 181-901-10:** V-block set with clamp (Max. workpiece dia.: 1")
- (See page J-22/23.) Detectors, styli, and nosepieces
*Use with an XY leveling table

Optional Accessories

A wide range of peripherals are available to support various challenging measurement needs.



Y-axis Table
178-097 for multiple workpiece measurement
178-096 for 3D measurement
*Not a measuring axis, only for positioning.



3D-Auto Leveling Table
178-077
*Used together with **178-096**



Digital Advanced Tilting Unit
178-040
*Contact Sales Rep for details. Recommend to be installed in manufacturer's facility.
(See page J-25 for more accessories.)



178-071 (S-3000)
Standard Detector Holder



178-075 (S-3000CR)
Crank Rotary Type Detector Holder



178-074 (S-3000C)
Crank Type Detector Holder



178-076 (S-3000MR)
Manual Rotary Type Detector Holder

Surftest Extreme SV-3000CNC

SERIES 178 — CNC Surface Measuring Instruments

FEATURES

- High-accuracy CNC surface roughness measuring instrument allows surface roughness measurement in both axes.
- Each axes has the maximum drive speed of 200 mm/s, which permits high-speed positioning that may result in a large increase in the throughput of multiple-profile/multiple-workpiece measurement tasks.
- For models with the α -axis, it is possible to perform continuous measurement over horizontal and inclined surfaces by power-tilting the drive unit.
- For models with the Y-axis table, it is possible to expand the measuring range for multiple workpieces, etc., through positioning in the Y-axis direction.
- Using optional rotary table $\theta 1$ and $\theta 2$ designed to use with the CNC models enables it to expand the CNC measurement application range.
- Inclined plane measurements is possible through 2-axis simultaneous control in the X- and Y-axis directions.
- Since the detector unit incorporates an anti-collision safety device, the detector unit will automatically stop even if its main body collides with a workpiece or fixture.
- Supplied with an easy-to-operate Remote Box. The user can make any movement by selecting the required axis using the two joysticks. The current axis selection is easily identified by the icon on the key top.
- Communication with the data processing/analysis section is via USB.



SV-3000CNC w/ PC system and software
PC stand is not included, isolation stand is optional

SPECIFICATIONS

Model No.	SV-3000CNC		SV-3000CNC		SV-3000CNC		SV-3000CNC	
Order No. (100V - 120V)	178-521-1	178-541-1	178-522-1	178-542-1	178-523-1	178-543-1	178-524-1	178-544-1
X1-axis measuring range	8" (200mm)	8" (200mm)	8" (200mm)	8" (200mm)	8" (200mm)	8" (200mm)	8" (200mm)	8" (200mm)
Z2-axis vertical travel	12" (300mm)	20" (500mm)	12" (300mm)	20" (500mm)	12" (300mm)	20" (500mm)	12" (300mm)	20" (500mm)
Y-axis table unit	—	—	—	—	Installed	Installed	Installed	Installed
α -axis unit	—	—	Installed	Installed	—	—	Installed	Installed

Technical Data: SV-3000CNC

X1-axis	Measuring range: 8" (200mm)
	Resolution: 1.97 μ m (0.05 μ m)
	Measurement method: Reflective-type linear encoder
	Drive speed: 7.87"/s (200mm/s) (CNC, max.)
	0 - 2.4"/s (0 - 60mm/s) (joystick)
	Measuring speed: .00078 - .078"/s (0.02 - 2mm/s)
	Traversing direction: Backward
	Traverse linearity: 20 μ m/8" (0.5 μ m/200mm)
α -axis**	Inclination angle: -45° to +10°
	Resolution: 0.000225°
	Rotating speed: 1rpm
Z2-axis (column)	Vertical travel: 12" (300mm) 20"*(500mm)
	Resolution: 1.97 μ m (0.05 μ m)
	Measurement method: Reflective-type linear encoder
	Drive speed: 7.87"/s (200mm/s) (max., CNC)
	0 - 2.4"/s (0 - 60mm/s) (joystick)
	Base size (W x H): 29.5 x 23.6" (750 x 600mm)
	Base material: Granite
Detector	Range / resolution: 32000 μ m / .4 μ m, 3200 μ m / .04 μ m, 320 μ m / .004 μ m (up to 96,000 μ m with an optional stylus) {800 μ m / 0.01 μ m, 80 μ m / 0.001 μ m, 8 μ m / 0.0001 μ m} (up to 2400 μ m with an optional stylus)}
	Measuring force: 4mN (0.75mN) (low-force type)
	Stylus tip: Diamond, 90°/5 μ mR (60°/2 μ mR: low-force type)
Dimension (W x D x H):	31.5 x 24.4 x 39.4" (800 x 620 x 1000mm)
	31.5 x 24.4 x 47.2" (800 x 620 x 1200mm)*
Mass	529 lbs (240kg) 551lbs (250kg)*
	*High-column model
Y-axis table unit**	Measuring range: 8" (200mm)
	Minimum reading: 1.97 μ m (0.05 μ m)
	Scale unit: Reflective-type Linear Encoder
	Drive speed: 7.87"/s (200mm/s) (max., CNC)
	0 - 2.4"/s (0 - 60mm/s) (joystick)
Maximum loading capacity:	44 lbs (20kg)
Traverse linearity	20 μ m/8" (0.5 μ m/200mm)
Linear displacement accuracy (at 20°C):	\pm (80+2L/4) μ m (\pm (2+2L/100) μ m)
	L: Dimension between two measured points (mm)
Table size:	7.87 x 7.87" (200 x 200mm)
Dimensions (W x D x H):	12.6 x 25.4 x 4.1" (320 x 646 x 105mm)
Mass:	77 lbs (35kg)
	**Y-axis table included only as a factory installed option.

Optional Accessories

Vibration isolation stand	Vibration isolation mechanism: Diaphragm air spring
Natural frequency :	2.5 - 3.5Hz
Damping mechanism:	Orifice
Leveling mechanism:	Automatic control with mechanical valves
Air supply pressure:	0.4MPa
Allowable loading capacity:	772 lbs (350kg)
Dimensions (W x D x H):	39.4 x 35.2 x 28.1" (1000 x 895 x 715mm)
Mass:	617 lbs (280kg)

Technical Data: SV-M3000CNC

X1-axis

Measuring range: 8" (200mm)
 Resolution: 1.97µin (0.05µm)
 Measurement method: Reflective-type linear encoder
 Drive speed: 7.87"/s (200mm/s) (max., CNC)
 0 - 1.97"/s (0 - 50mm/s) (joystick)
 Measuring speed: .00078 - .08"/s (0.02 - 2mm/s)
 Traverse linearity: 20µin/8" (0.5µm/200mm)
 28µin/8" (0.7µm/200mm)
 (long-type detector)
 20µin/8" (0.5µm/200mm)
 (rotary-type detector,
 up/down direction)
 28µin/8" (0.7µm/200mm)
 (long-type detector,
 forward/backward direction)

α-axis

Inclination angle: -45° to +10°
 Resolution: 0.000225°
 Rotating speed: 1rpm

Z2-axis (column)

Vertical travel: 20" (500mm)
 Resolution: 1.97µin (0.05µm)
 Measurement method: Reflective-type linear encoder
 Drive speed: 7.87"/s (200mm/s) (CNC, max.)
 0 - 1.97"/s (0 - 50mm/s) (joystick)

Y-axis

Measuring range: 32" (800mm)
 Resolution: 1.97µin (0.05µm)
 Measurement method: Reflective-type linear encoder
 Drive speed: 7.87"/s (200mm/s) (max., CNC)
 0 - 1.97"/s (0 - 50mm/s) (joystick)
 Measuring speed: .00078 - .08"/s (0.02 - 2mm/s)
 Traverse linearity: 20µin/2" (0.5µm/50mm), 80µin/32"
 (2µm/800mm) 28µin/2" (0.7µm/50mm),
 120µin/32" (3µm/800mm)
 (long-type detector)
 28µin/2" (0.7µm/50mm),
 120µin/32" (3µm/800mm)
 (rotary-type detector, up/down direction)

Base unit

Size (W x H): 23.6 x 59.1" (600 x 1500mm)
 Material: Steel
 Loading capacity: 661 lbs (300kg)

Detector

Range / resolution: 32000µin / .4µin, 3200µin / .04µin,
 320µin / .004µin
 (up to 96,000µin with an optional stylus)
 {800µm / 0.01µm, 80µm / 0.001µm,
 8µm / 0.0001µm (up to 2400µm with
 an optional stylus)}
 Detecting method: Skidless / skid measurement
 Measuring force: 4mN or 0.75mN (low-force type)
 Stylus tip: Diamond, 90°/5µmR
 (60°/2µmR: low-force type)
 Skid radius of curvature: 1.57" (40mm)
 Detecting method: Differential inductance
 Dimension (W x D x H): 42.7 x 66.7 x 75.7"
 (1085 x 1695 x 1922mm)
 Mass: 3527 lbs (1600Kg)
 (including vibration isolating unit)

MiCAT

Mitutoyo Intelligent Computer Aided Technology

the standard in world
 metrology software
FORM

Software

FORMTRACEPAK V5

Enables control of the optional motor-driven Y-axis table and rotary table for realizing efficient measurement automation. You can also perform contour evaluation that allows free analysis of level differences, angle, pitch, area and other characteristics based on surface roughness data. In addition, analysis results can be saved in the "html", "mhtml" or pdf format which allows Internet Explorer or MS-Word compatibility, allowing PC without layout editing programs to view analysis results.



Contour Measurement & Surface Roughness Measurement Screen



Report Layout Screen

Surftest Extreme SV-M3000CNC

SERIES 178 — CNC Surface Measuring Instruments



SV-M3000CNC with personal computer system and software

* PC stand not included

FEATURES

- CNC Surface Roughness Tester covers measurement of large/heavy workpieces such as engine blocks, crankshafts, etc.
- In combination with the surface roughness detector rotating unit, S-3000AR (optional), it can perform continuous measurement over the bottom, top and side surfaces of a workpiece.
- Compatible with the optional large table for supporting a load of 220 lbs (100 kg) or a large θ2 table. Enables continuous automatic measurement of large-size workpieces.
- Suitable for automatic surface roughness measurement on large and heavy workpieces.
- Employs the column-moving type configuration that is not restricted by workpiece size. This is advantageous for measuring heavy workpieces, such as engine blocks, crankshafts, etc.
- Provides 31.5" (800mm) of Y-axis stroke. This makes it possible to measure multiple profiles on large workpieces.
- Load table has a self-contained structure to ensure that various size workpieces, jigs, auto-feed devices, etc., are easily accommodated and can be specified, if required, by special order.

SPECIFICATIONS

Model No.	SV-M3000CNC
Order No. (100V - 120V)	178-549-1
X1-axis measuring range	8" (200mm)
Z2-axis column travel range	20" (500mm)
Y-axis travel range	32" (800mm)
α-axis inclination angle	-45° (CCW), +10° (CW)