

# Calibration Standards/Instruments and Accredited Calibration Services

Catalog No. E4163



Accredited Calibration Services for Implementing  
Traceability of Measurements from a World Leader in  
Dimensional Metrology.

**Mitutoyo**



# INDEX

Traceability of the accuracy of measuring instruments put its basis on the calibration standards and instruments that are traceable to nationally or internationally recognized standards. Here is an introduction to our accredited calibration laboratories, traceability system based manufacturing/sales/service activities conducted worldwide followed by a quick reference to calibration standards and instruments available from Mitutoyo as appropriate for maintaining the accuracy of precision measuring tools and instruments.

Traceability System to National Standard	4
Worldwide Accredited Calibration Laboratories	6
Conformance to CE Marking	7
Gauge Blocks ... the basic reference in metrology ....	8
Calibration standards/instruments available from Mitutoyo for the measuring instruments	

## Gauge blocks

Automatic Gauge Block Interferometer GBI	10
Frequency Stabilized He-Ne Laser Light Source	10
Long Gauge Block Interferometer LGBI	11
Differential Type Automatic Gauge Block Comparator GBCD-100A	11
Differential Type Manual Gauge Block Comparator GBCD-250	12
Manual Gauge Block Comparator GBCS-250	12

## Ring gauges

Ring Gage Measuring Machine, Ring Master RM-120	13
---	----

## Outside micrometers

Gauge Block Set for Micrometer Inspection	14
Micrometer Standards	14
Optical Parallels	14
Optical Flats	14

## Inside Micrometers

CERA-Inside Micro-Checker	15
Bore Gages	
Height Master	19
Depth Micrometers	
Depth Micro-Checker	15

## Calipers

CERA Caliper Checker	15
----------------------	----

## Height Gages

CERA Caliper Checker	17
Height Master	19
Check Master	16

## CMMs/Machine Tools

Granite Surface Plate (Graplate)	19
----------------------------------	----

## Dial Indicators/Dial Test Indicators

Dial Gage Tester (170 Series)	17
Calibration Tester (521 Series)	17
Electronic Micrometers	
Calibration Tester (521 Series)	17

## Coordinate Measuring Machines

Check Master	16
Quadra-Square Master	16

## Profile Projectors/Measuring Microscopes

Standard Scales and Reading Scales (172 series)	18
Standard Scales (182 series)	18
Working Standard Scales (182 series)	18
Snap Gages (C-gages)	
Snap Gage Checker	19

## Height Measurement Standard/Surface Plate

Height Master/Graplate	19
------------------------	----

# Scope of end standard calibration

## At Utsunomiya Calibration Center

Type Comparison

Range 0.6mm up to 600mm (at comparison)

Measurement uncertainty (coverage factor K=2)

0.5mm up to 100mm 0.06 $\mu$ m

Over 100mm up to 600mm  $(0.03+L/2300)\mu$ m\*

Laser wavelength

Range 633nm

Measurement uncertainty (coverage factor K=2)  $(5.0 \times 10^{-11})$

Standard scale

Range Up to 500mm

Measurement uncertainty (coverage factor K=2)

Up to 300mm 0.33 $\mu$ m

Over 300mm up to 500mm  $(0.3+L/10000)\mu$ m

Temperature

Range 0°C up to 40°C

Type Comparison

Measurement uncertainty (coverage factor K=2)

Up to 300mm 0.33 $\mu$ m

Over 300mm up to 500mm  $(0.3+L/10000)\mu$ m

Platinum Resistance Thermometer

(Four wires system, 100 $\Omega$ ) ——— 6mK

Platinum Resistance Thermometer

(Three wires system, 1000 $\Omega$ ) ——— 50mK

Thermometer with Indicator 8mK

\*L=nominal length ( $\mu$ m)



## At Miyazaki Plant

Type Interferometry and Comparison

Range 0.1mm up to 1000mm

Measurement uncertainty (coverage factor k=2)

0.1mm up to 100mm 0.04 $\mu$ m

Over 100mm up to 600mm  $(0.02+L/4000)\mu$ m\*

\*L=nominal length ( $\mu$ m)



# Traceability System to National Standard

## Mitutoyo Group Accredited Calibration Laboratories

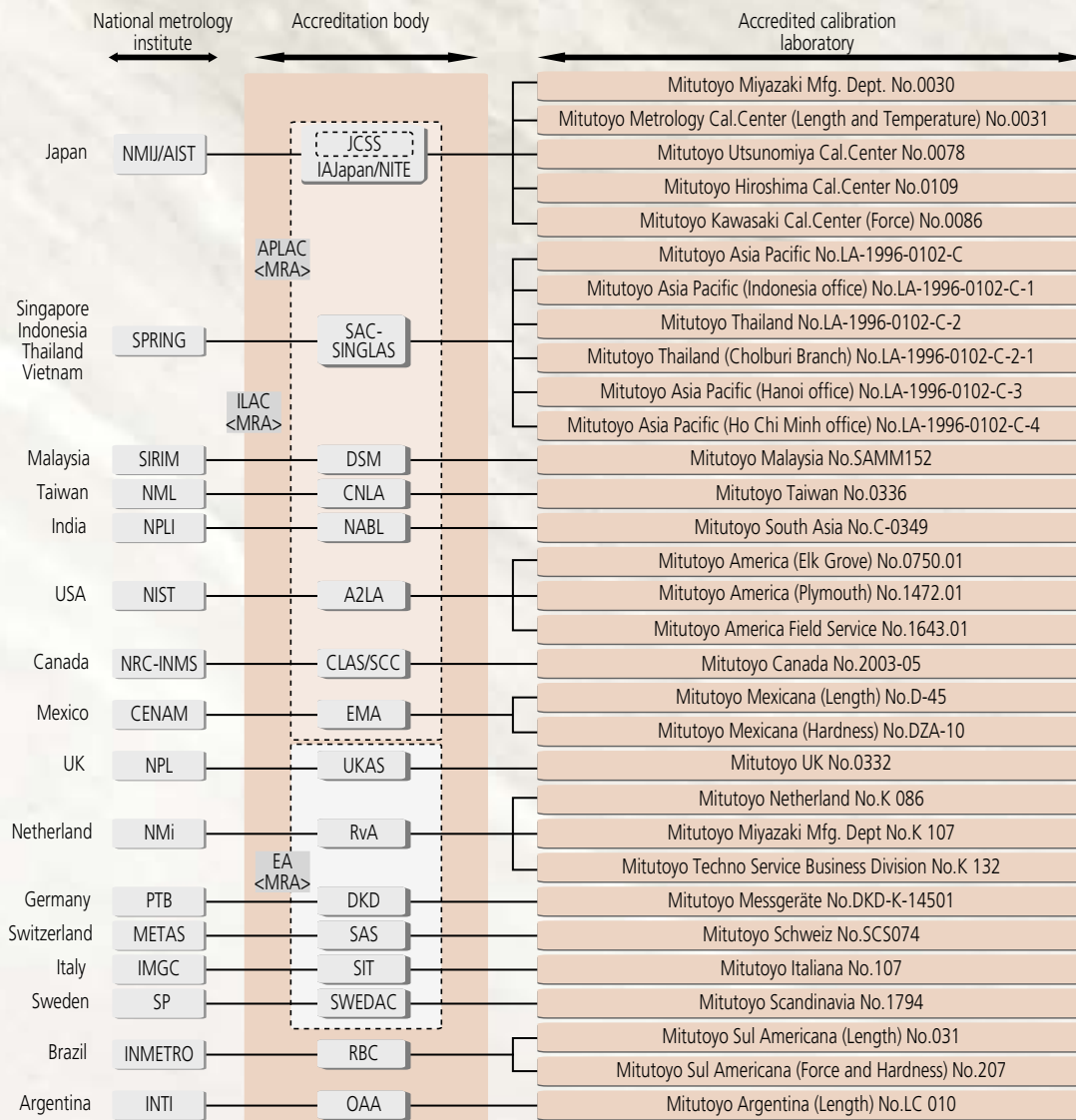

AIST: National Institute of Advanced Industrial Science and Technology  
 NMIJ: National Metrology Institute of Japan  
 JCSS: Japan Calibration Service System  
 NITE: National Institute of Technology and Evaluation  
 IAJapan: International Accreditation Japan  
 SPRING: Standards, Productivity and Innovation Board  
 SAC: Singapore Accreditation Council  
 NML: National Measurement Laboratory  
 CNLA: Chinese National Laboratory Accreditation  
 SIRIM: Standards and Industrial Research Institute of Malaysia  
 DSM: Department of Standards Malaysia  
 NIST: National Institute of Standards and Technology

A2LA: American Association for Laboratory Accreditation  
 NRC-INMS: National Research Council of Canada -Institute for National Measurement Standards  
 CLAS: Calibration Laboratory Assessment Service  
 SCC: Standards Council of Canada  
 CENAM: Centro Nacional de Metrología  
 EMA: Entidad Mexicana de Acreditación, a.c.  
 NPL: National Physical Laboratory  
 UKAS: United Kingdom Accreditation Service  
 NMI: Nederlands Meetinstituut  
 RvA: Raad voor Accreditatie  
 PTB: Physikalisch-Technische Bundesanstalt  
 DKD: Deutscher Kalibrierdienst  
 METAS: The Swiss Federal Office of Metrology and Accreditation  
 SAS: Swiss Accreditation Service  
 IMGC: Istituto di Metrologia "GUSTAVO COLONNETTI"

SIT: Servizio di Taratura in Italia  
 SP: Swedish National Testing and Research Institute  
 SWEDAC: Swedish Board for Accreditation and Conformity Assessment  
 INMETRO: Instituto Nacional de Metrologia Normalização e Qualidade Industrial  
 RBC: Rede Brasileira de Calibração  
 INTI: Instituto Nacional de Tecnología Industrial  
 OAA: Organismo Argentino de Acreditación  
 NPL: National Physical Laboratory of India  
 NABL: National Accreditation Board for Testing and Calibration Laboratories  
 (ILAC): International Laboratory Accreditation Cooperation  
 (APLAC): Asia-Pacific Laboratory Accreditation Cooperation  
 (EA): European Accreditation Cooperation  
 (MRA): Mutual Recognition Arrangement  
 #: Accreditation No.





Traceability system of length standard: Property of the result of a measurement or the value of a standard whereby it can be related to stated reference, usually national or international standards, through an unbroken chain of comparisons all having stated uncertainties. Traceability of the accuracy of measuring instruments: A documented chain of comparison connecting the accuracy of a measuring instrument to other measuring instruments of higher accuracy and ultimately to a primary standard.

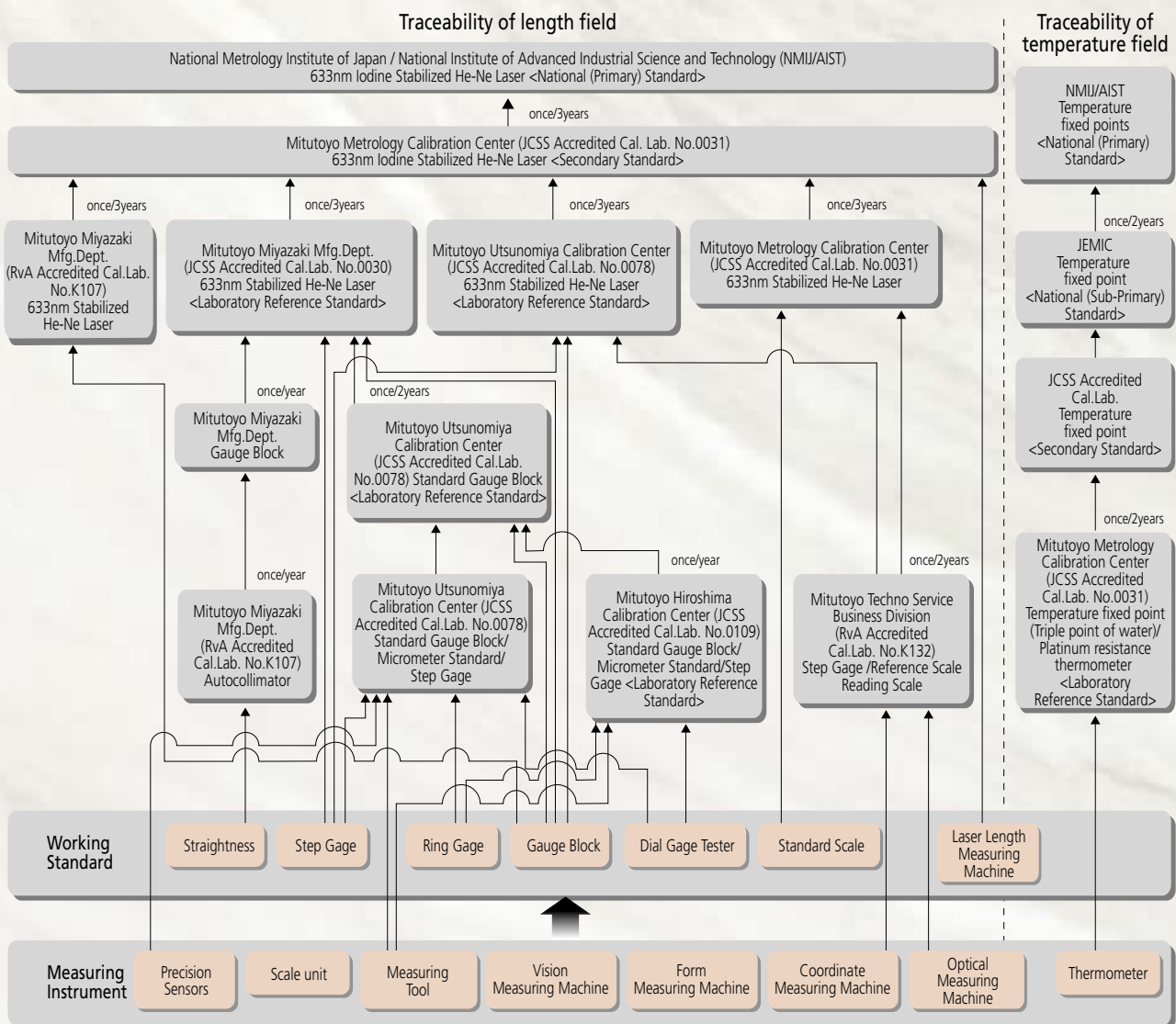

# Worldwide Accredited Calibration Laboratories

Being nationally accredited calibration laboratories, Mitutoyo conducts calibration services at various parts of the globe to help customers implement and maintain the traceability of accuracy of their precision measuring tools and instruments. Scope of calibration service at each of our 16 accredited calibration laboratories is shown below.

Calibration: A set of operations which establishes, under specified conditions, the relationship between values indicated by measuring instrument or system, or values represented by a material measure or a reference material, and the corresponding known values realized by standards. (VIM, 1993)

Department of accreditation	Registered	Scope Standard	Accreditation body of calibration service	Accreditation	Accredited No. date
Miyazaki Plant	ISO/IEC 17025	Gauge Block	NITE/IAJapan (JCSS)	0030	1994-05-02
	ISO/IEC 17025	Gauge Block, Cera Straight Maser	RvA	K 107	1997-02-20
Kiyohara Calibration Center	ISO/IEC 17025	Line Standard (Standard Scale)	NITE/IAJapan (JCSS)	0067	1996-08-07
Tsukuba Calibration Center	ISO/IEC 17025	Laser Platinum Resistance Thermometer, Thermometer with Indicator	NITE/IAJapan (JCSS)	0031	1994-05-02 2003-12-10
Utsunomiya Calibration Center	ISO/IEC 17025	Gauge Block, Step Gage, Caliper...etc (11item)	NITE/IAJapan (JCSS)	0078	1998-05-06
Kawasaki Calibration Center	ISO/IEC 17025	Caliper, Micrometer, Electronic Micrometer...etc (4item)	RvA	K 125	2001-01-24
Hiroshima Calibration Center	ISO/IEC 17025	Step Gage, Caliper...etc (8item)	NITE/IAJapan (JCSS)	0109	2002-04-11
Techno Service Business Division	ISO/IEC 17025	CMM, Profile projectors, Measuring microscopes	RvA	K 132	2003-12-17
Mitutoyo (UK)	ISO/IEC 17025	Gauge Block, Caliper, CMM...etc (40item)	UKAS	0332	1991-07-30
MAS Length	ISO/IEC 17025	Gauge Block, Caliper, CMM...etc (19item)	RBC	031	1992-09-15
MAS Hardness	ISO/IEC 17025	Rockwell Tester	RBC	207	2002-09-20
Argentine	ISO/IEC 17025	Rockwell Tester	OAA	LC 010	2002-11-07
Mitutoyo (NL)	ISO/IEC 17025	Gauge Block, Caliper, CMM...etc (12item)	RvA	K 086	1994-10-14
Mitutoyo (D)	ISO/IEC 17025	Gauge Block, Caliper...etc (10item)	DKD	DKD-K-14501	1995-01-10
MAP Singapore	ISO/IEC 17025	Gauge Block, Caliper, CMM...etc (15item)	SAC-SINGLAS	LA-1996-0102-C	1996-11-08
MAP Indonesia	ISO/IEC 17025	Surface roughness instruments, CMM...etc (7item)	SAC-SINGLAS	LA-1996-0102-C-1	2003-06-14
Mitutoyo (Switzerland)	ISO/IEC 17025	Gauge Block, Caliper, CMM...etc (9item)	SAS	SCS 074	1996-12-1
MAC Elk Grove Lab.	ISO/IEC 17025	Gauge Block, Caliper, CMM...etc (27item)	A2LA	0750.01	1998-04-20
MAC Plymouth Lab.	ISO/IEC 17025	Gauge Block, Caliper, Electronic Micrometer...etc (10item)	A2LA	1472.01	2000-02-03
MAC Aurora (field)	ISO/IEC 17025	CMM, Vision Measuring Machine...etc (5item)	A2LA	1643.01	2002-01-15
Mitutoyo (I)	ISO/IEC 17025	Gauge Block, Roundness standards, CMM...etc (4item)	SIT	107	1998-05-01
Mitutoyo (Taiwan)	ISO/IEC 17025	Surface finish specimen, Toolmaker Microscope, CMM...etc (5item)	CNLA	0336	1998-06-15
Mitutoyo (Malaysia)	ISO/IEC 17025	Caliper, Surface roughness instruments, CMM...etc (13item)	SAMM	SAMM-152	1998-10-15
Mitutoyo Length (Mex)	ISO/IEC 17025	Gauge Block, Caliper, CMM...etc (20item)	EMA	D-45	2000-11-21
Mitutoyo Hardness (Scandinavia)	ISO/IEC 17025	Rockwell Tester	EMA	DZA-10	2003-02-18
Mitutoyo (Scandinavia)	ISO/IEC 17025	Gauge Block, CMM	SWEDAC	1794	2002-03-04

NITE: National Institute of Technology and Evaluation  
 JCSS: Japan Calibration Service System  
 RvA NKO: Nederlandse Kalibratie Organisatie  
 UKAS: United Kingdom Accreditation Service  
 RBC: Rede Brasileira de Calibração

DKD: Deutscher Kalibrierdienst  
 SAC: Singapore Accreditation Council  
 SACSINGLAS: Singapore Accreditation Council-Singapore Laboratory  
 SINGLAS: Accreditation Scheme  
 SAS: Swiss Accreditation Service  
 A2LA: American Association for Laboratory Accreditation  
 SIT: Servizio di Taratura in Italia

CNLA: Chinese National Laboratory Accreditation  
 DSM: Department of Standards Malaysia  
 SAMM: Skim Akreditasi Makmal Malaysia  
 TISI: Thai Industrial Standard Institute  
 EMA: Entidad Mexicana de Acreditación, a.c.  
 SINGLAS: Accreditation Scheme  
 SWEDAC: Swedish Board for Accreditation and Conformity Assessment

# Conformance to CE Marking

Safety is one of our major concerns associated with quality assurance in serving customers. Conformance to CE marking is a means of our safety improvement activities and so established and implemented are programs at each plant to comply with the Machinery Directives, the EMC Directives, and the Low Voltage Directives as appropriate. We have set up facilities for CE marking compliance evaluation. Products being shipped with the CE mark conforms to the requirements set forth by the European Community for safety, health, environment and customer protection. (CE stands for "Conformite Europeenne".)



Compliance evaluation of CE marking in Mitutoyo facility (EMC Directives)



## EC Directives concerned

NEC Directives	Scope	Date effective
Machinery Directive	Products that may result in personal injury due to moving parts of the machine, including motors, etc.	January 1st, 1995
EMC Directive (Electromagnetic Compatibility)	Tools (instruments) that are subject to electromagnetic interference or tools (instruments) of which the performance is subject to such interference.	January 1st, 1996
Low Voltage Directive	Tools (instruments) in which there is a risk of receiving an electric shock, burn, radioactivity, etc., and that operate on either of the following voltages: AC voltage: 50 to 1000V DC voltage: 75 to 15000V	January 1st, 1997

# Gauge Blocks ...the basic reference in metrology...

## Rectangular Gauge Block

Steel and ceramic-type gauge blocks are offered.



103-piece set (steel)



103-piece set (ceramic)



Long gauge block set

## Order No. (DIN/JIS block set only)

Type	Blocks per set	Accuracy	Steel	Ceramic
1mm base sets	112	Grade K	516-937-60	516-337-60
		Grade 0	516-938-10	516-338-10
		Grade 1	516-939-10	516-339-10
		Grade 2	516-940-10	516-340-10
	103	Grade K	516-941-60	516-341-60
		Grade 0	516-942-10	516-342-10
		Grade 1	516-943-10	516-343-10
		Grade 2	516-944-10	516-344-10
	88	Grade 0	516-970-10	—
		Grade 1	516-971-10	—
		Grade 2	516-972-10	—
	87	Grade K	516-945-60	516-345-60
Grade 0		516-946-10	516-346-10	
Grade 1		516-947-10	516-347-10	
Grade 2		516-948-10	516-348-10	
76	Grade K	516-949-60	516-349-60	
	Grade 0	516-950-10	516-350-10	
	Grade 1	516-951-10	516-351-10	
	Grade 2	516-952-10	516-352-10	
56	Grade K	516-953-60	516-353-60	
	Grade 0	516-954-10	516-354-10	
	Grade 1	516-955-10	516-355-10	
	Grade 2	516-956-10	516-356-10	
47	Grade K	516-957-60	516-357-60	
	Grade 0	516-958-10	516-358-10	
	Grade 1	516-959-10	516-359-10	
	Grade 2	516-960-10	516-360-10	
47	Grade K	516-961-60	516-361-60	
	Grade 0	516-962-10	516-362-10	
	Grade 1	516-963-10	516-363-10	
	Grade 2	516-964-10	516-364-10	
46	Grade K	516-994-60	516-394-60	
	Grade 0	516-995-10	516-395-10	
	Grade 1	516-996-10	516-396-10	
	Grade 2	516-997-10	516-397-10	
32	Grade K	516-965-60	516-365-60	
	Grade 0	516-966-10	516-366-10	
	Grade 1	516-967-10	516-367-10	
	Grade 2	516-968-10	516-368-10	

Type	Blocks per set	Accuracy	Steel	Ceramic
2mm base sets	112	Grade K	516-513-60	—
		Grade 0	516-514-10	—
		Grade 1	516-515-10	—
		Grade 2	516-516-10	—
	88	Grade K	516-501-60	—
		Grade 0	516-502-10	—
		Grade 1	516-503-10	—
		Grade 2	516-504-10	—
	88	Grade K	516-517-60	—
		Grade 0	516-518-10	—
		Grade 1	516-519-10	—
		Grade 2	516-520-10	—
47	Grade K	516-521-60	—	
	Grade 0	516-522-10	—	
	Grade 1	516-523-10	—	
	Grade 2	516-524-10	—	
46	Grade K	516-505-60	—	
	Grade 0	516-506-10	—	
	Grade 1	516-507-10	—	
	Grade 2	516-508-10	—	
33	Grade K	516-509-60	—	
	Grade 0	516-510-10	—	
	Grade 1	516-511-10	—	
	Grade 2	516-512-10	—	
0.001mm step block sets	18	Grade K	516-973-60	516-373-60
		Grade 0	516-974-10	516-374-10
		Grade 1	516-975-10	516-375-10
		Grade 2	516-976-10	516-376-10
9	9	Grade K	516-981-60	516-381-60
		Grade 0	516-982-10	516-382-10
		Grade 1	516-983-10	516-383-10
		Grade 2	516-984-10	516-384-10
9	9	Grade K	516-985-60	516-385-60
		Grade 0	516-986-10	516-386-10
		Grade 1	516-987-10	516-387-10
		Grade 2	516-988-10	516-388-10
Thin block sets	9	Grade 0	516-990-10	—
		Grade 1	516-991-10	—
		Grade 2	516-992-10	—
Long Block set	8	Grade K	516-701-60	516-731-60
		Grade 0	516-702-10	516-732-10
		Grade 1	516-703-10	516-733-10
		Grade 2	516-704-10	516-734-10
Wear block sets*	2	Grade 0	516-807-10	516-832-10
		Grade 1	516-806-10	516-833-10
2	2	Grade 0	516-803-10	516-830-10
		Grade 1	516-802-10	516-831-10

Grade K gauge blocks are complete with the Certificate of Inspection and Certificate of Calibration.  
\* Wear blocks are made of tungsten carbide.



The most popular end standard in industrial dimensional measurement is available in both the rectangular gauge block and square gauge block in type and in steel or ceramic in material.

## Square Gauge Block

The gauge blocks have a square measurement surface of 24.1x24.1mm and a  $\phi 6.7$ mm through hole at the center to improve ease-of-use and for use in a wide range applications.

- > These gauge blocks can be wrung to one another and can be used for making tools and dedicated gages.
- > Gauge blocks can be joined using the optional tie rod, screws, and nuts.



112-piece set

### Order No. (DIN/JIS block set only)

Blocks per set	Accuracy	Steel	Ceramic
112	Grade 0	<b>516-438-10</b>	—
	Grade 1	<b>516-439-10</b>	—
	Grade 2	<b>516-440-10</b>	—
103	Grade 0	<b>516-442-10</b>	—
	Grade 1	<b>516-443-10</b>	—
	Grade 2	<b>516-444-10</b>	—
76	Grade 0	<b>516-450-10</b>	—
	Grade 1	<b>516-451-10</b>	—
	Grade 2	<b>516-452-10</b>	—
47	Grade 0	<b>516-458-10</b>	—
	Grade 1	<b>516-459-10</b>	—
	Grade 2	<b>516-460-10</b>	—
32	Grade 0	<b>516-466-10</b>	—
	Grade 1	<b>516-467-10</b>	—
	Grade 2	<b>516-468-10</b>	—
8*	Grade 0	<b>516-752-10</b>	—
	Grade 1	<b>516-753-10</b>	—
	Grade 2	<b>516-754-10</b>	—
2**	Grade 0	<b>516-820-10</b>	—
	Grade 1	<b>516-821-10</b>	—
2**	Grade 0	<b>516-822-10</b>	—
	Grade 1	<b>516-823-10</b>	—

Provided with Certificate of Inspection.

\*Long gauge block set.

\*\*Wear gauge block sets made of carbide.

## Individual Gauge Block

- > If frequently measuring a specific length, it is a good idea to purchase an individual gauge block.



\*For more information about individual block lengths, refer to Catalog No. E4092 "Gauge Blocks".

## Gauge Block Accessory Sets

To expand the variety of rectangular gauge block applications, Mitutoyo offers the Gauge Block Accessories Set. By assembling the items in the set, you can build up various precision measuring setups with gauge blocks easily and quickly.

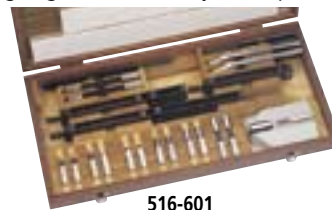

516-601  
Rectangular gauge block accessory set



516-611  
Square gauge block accessory set

### Order No.

Order No.	Description
<b>516-601</b>	22-piece set for rectangular gauge block
<b>516-602</b>	14-piece set for rectangular gauge block
<b>516-605</b>	For long rectangular gauge block (over 125mm)
<b>516-611</b>	For square gauge block

## Micro Checker

- > Can be measured in both vertical and horizontal posture.
- > Parallelism is measured by attaching the Optical parallel (optional accessory) to the GB set.

Order No.	516-607 (mm type)	516-608 (inch type)
Applicable Gauge Block	<b>516-106, 516-107, 516-108, 516-156, 516-157, 516-158</b>	<b>516-921, 516-922, 516-923, 516-321, 516-322, 516-323</b>
Applicable Gauge Block size	2.5, 5.1, 7.7, 10.3, 12.9, 15, 17.6, 20.2, 22.8, 25mm	.105, .210, .315, .420, .5, .605, .710, .815, .920inch
Mass	NW1300g	GW1300g/2.87lbs.(with wooden box)



# Gauge Block Calibration

## Automatic Gauge Block Interferometer GBI

The Two-Wavelength Automatic Gauge Block Interferometer, GBI is an easy to use gauge block interferometer capable of absolute measurement of central length of gauge blocks with the utmost accuracy.

- > Two He-Ne laser light sources are adapted to ensure extremely reliable measurements. Preliminary measurement with up to 1 μm uncertainty is satisfactory for interferometry with the GBI.
- > No human intervention in observing the interference fringes. This eliminates human errors in measurements.
- > Remote control of the system is possible in measurement. This facilitates preventing the operator heat from affecting the gauge blocks inside the interferometer.
- > Air refractive index correction and gauge block thermal expansion correction are automatically performed with the computer connected to the thermometer, hygrometer, and barometer.
- > An array of 12 gauge blocks set up within the interferometer can be continuously measured within 5 minutes for each block.



### Specifications

Light source	He-Ne laser (633nm and 543nm)
Measuring range	Up to 250mm
Uncertainty of measurement: (Coverage factor k=2)	0.025μm+0.2x10 <sup>-6</sup> L L=nominal length (μm)
Number of blocks installable	12 pcs.

## Frequency Stabilized He-Ne Laser Light Source

### LIS-633B, LIS-543

Frequency stabilized He-Ne laser is available as a light source for such applications as length measurement, interferometry, spectrograph, and holography.

- > Frequency stabilized high intensity single mode linear polarized He-Ne laser.

### Specifications

Model	LIS-633B	LIS-543
Wavelength	633nm	543nm
Wavelength stability	1X10 <sup>-8</sup> /year	2X10 <sup>-8</sup> /year
Output	1mW or over	150μW or over
Beam diameter	0.6mm	0.6mm
Class	Class 3B	Class 3A
Ambient temperature	20°C±5°C	20°C±5°C
Dimensions (WxHxD)	134x121x396mm	134x121x396mm

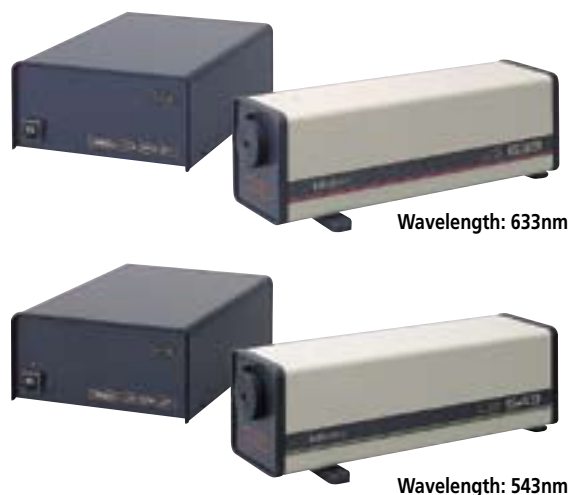

# Gauge Block Calibration

## Automatic Gauge Block Interferometer GBI

Target preliminary measurement range expanded sevenfold with two wavelengths

This interferometer determines the deviation of the central length of long rectangular gauge blocks of 100mm to 1016mm with high accuracy. A maximum of 4 gauge blocks can be set up at a time, permitting measurements to be performed efficiently with the reduced time for thermal stabilization of the gauge blocks.

- > Two He-Ne laser light sources are adopted to ensure extremely reliable measurements. Preliminary measurement with up to 1 $\mu$ m uncertainty is satisfactory for interferometry with the LGBI.
- > Observation of interference fringe is possible either via CCD camera (optional) or eyepiece lens.
- > The interferometer chamber can accommodate up to 4 gauge blocks.
- > Gauge blocks can be set up horizontally at Airy points (0.211L from each end).
- > Air refractive index correction is possible by directly measuring the index in the vacuum cell or by measuring temperature, humidity and barometric pressure.

Two wavelengths

Horizontal type



### Specifications

Light source	He-Ne laser (633nm and 543nm)
Measuring range	100mm to 1016mm
Calibration function	Absolute optical path length difference measurement with gauge block wrung to the platen
Uncertainty of measurement: (Coverage factor k=2)	0.03 $\mu$ m+0.2 $\times$ 10 $^{-6}$ L L=nominal length ( $\mu$ m)

\*95% confidence coefficient  
Excluding uncertainty of reference gauge block length

## Differential Type Automatic Gauge Block Comparator GBCD-100A

ISO recommended differential type with dual gage head for automatic high accuracy measurement

Dual head type of gauge block comparator capable of automatic calibration of gauge block lengths between 0.5mm and 100mm with reference to the reference gauge block.

- > Dual head feature eliminates the error due to the warp of thin gauge block.
- > Automatically measures the center and four corners of a gauge block with reference to the central length of the reference gauge block.
- > Calibration results are automatically processed with the GBPAK Calibration Program.
- > Measurements for evaluation with ISO, JIS, DIN, ANSI, etc.

### Specifications

Applications	Rectangular gauge blocks and square gauge blocks
Measuring range	0.5mm to 100mm
Display resolution	0.01 $\mu$ m
Measurement method	Differential measurement with dual head
Upper gaging head	Electric micrometer of 1N measuring force Carbide contact point of radius of 20mm
Lower gaging head	Electric micrometer of 0.6N measuring force Carbide contact point of radius of 5mm
Accuracy (20°C)*	$\pm(0.03+0.3L/1000)\mu$ m, L=nominal length (mm)
Air requirement	400KPa
Temperature	20°C $\pm$ 1°C
Dimensions (WxDxH)	Measuring unit 710x366x783mm Electronic unit 160x410x382mm

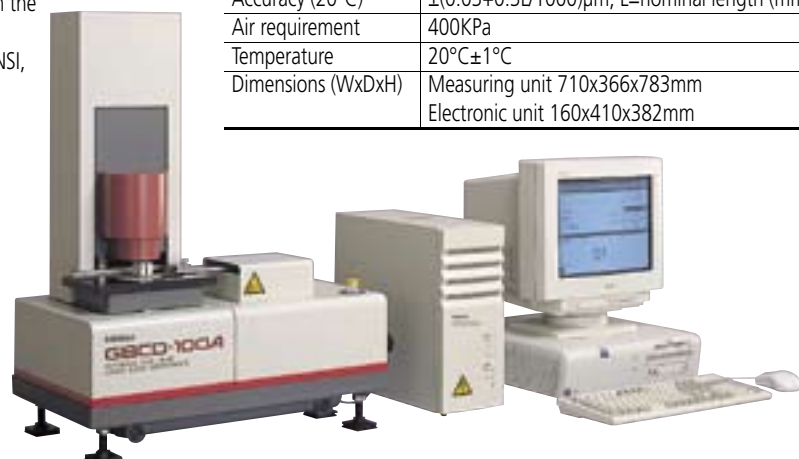
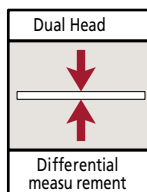

# Gauge Block Calibration

## Differential Type Manual Gauge Block Comparator GBCD-250

ISO recommended differential type with dual gage head.  
Long range Laser Hologage ( $\pm 3\text{mm}$ ) allows 103 pieces gauge block set to be calibrated with a minimum number of reference gages.

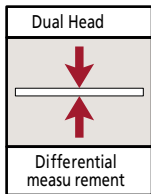

The GBCD-250 is a dual head type manual gauge block comparator capable of calibrating a wide range of gauge block lengths between 0.1mm and 250mm with a resolution to  $0.01\mu\text{m}$  with the Mitutoyo Laser Hologage.

- > Dual head feature eliminates the error due to warp of thin gauge blocks.
- > A 103 gauge block set of grade 1 or 2 can be calibrated with only 8 reference gauge blocks thanks to the  $\pm 3\text{mm}$  measuring range of the Laser Hologage.
- > The Laser Hologage needs height positioning only to within  $\pm 1\text{mm}$  otherwise required to within a few microns ( $\mu\text{m}$ ), greatly reducing setup time.

### Specifications

Applications	Rectangular gauge blocks and square gauge blocks
Measuring range	0.1mm to 250mm
Resolution	$0.01\mu\text{m}$
Measurement method	Differential measurement with dual head
Upper gaging head	Laser Hologage ( $0.01\mu\text{m}$ , $\pm 3\text{mm}$ ) of 0.8N measuring force Carbide contact point of radius of 20mm
Lower gaging head	Electric micrometer of 0.6N measuring force Carbide contact point of radius of 5mm
Accuracy ( $20^\circ\text{C}$ )*	$\pm(0.03+0.3L/1000)\mu\text{m}$ , L=nominal length (mm) (the nominal length must be the same for both the reference gauge block and the one to be calibrated) $\pm(0.06+0.3L/1000)\mu\text{m}$ , L=nominal length (mm) (for grades 1 and 2: with the reference gauge block of length difference within $\pm 3\text{mm}$ )
Temperature	$20^\circ\text{C}\pm 1^\circ\text{C}$
Dimensions (WxDxH)	Measuring unit 455x318x691mm Electronic unit 345x397x187mm (Excluding connectors)

\* 95% confidence coefficient  
 Excluding uncertainty of reference gauge block length  
 GBPAK Calibration Program and personal computer are optional.

## Manual Gauge Block Comparator GBCS-250

Long range Laser Hologage ( $\pm 5\text{mm}$ ) allows 103 pieces gauge block set to be calibrated with a minimum number of reference gages.

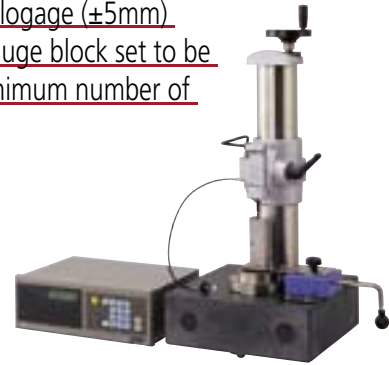
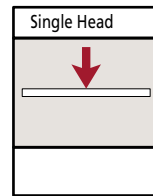

Single head type gauge block comparator capable of calibration of gauge blocks of length of 0.1mm up to 250mm with reference to the reference gauge blocks.

- > Integrated with the Mitutoyo Laser Hologage ( $\pm 5\text{mm}$  range), the GBCS-250 can calibrate a 103 gauge block set by using only 6 (for grade 2) or 8 (for grade 1) reference gauge blocks with the length difference of  $\pm 5\text{mm}$ . The Laser Hologage height positioning is required only to within 1mm against the reference gauge block otherwise required to within a few microns ( $\mu\text{m}$ ), greatly reducing setup time.

### Specifications

Applications	Rectangular gauge blocks and square gauge blocks
Measuring range	0.1mm to 250mm
Resolution	$0.01\mu\text{m}$
Measurement method	Single head
Gage head	Laser Hologage ( $0.01\mu\text{m}$ , $\pm 5\text{mm}$ ) of 0.8N measuring force Carbide contact point of radius of 20mm Anvil has a curvature
Accuracy ( $20^\circ\text{C}$ )*	$\pm(0.03+0.3L/1000)\mu\text{m}$ , L=nominal length (mm) (the nominal length must be the same for both the reference gauge block and the one to be calibrated) $\pm(0.06+0.3L/1000)\mu\text{m}$ , L=nominal length (mm) (for grades 1 and 2: with the reference gauge block of length difference within $\pm 3\text{mm}$ ) $\pm(0.1+0.3L/1000)\mu\text{m}$ , L=nominal length (mm) (for grades 2: with the reference gauge block of length difference within $\pm 5\text{mm}$ )
Temperature	$20^\circ\text{C}\pm 1^\circ\text{C}$
Dimensions (WxDxH)	Measuring unit 300x300x686.5mm Electronic unit 235x115x118mm (Excluding connectors)

\* 95% confidence coefficient  
 Excluding uncertainty of reference gauge block length  
 GBPAK Calibration Program and personal computer are optional.



# Ring Gage Calibration

## Ring Gage Measuring Machine Ring Master RM-120

Incorporated 120mm Laser Hologscale eliminates the need for multiple reference gages, permitting expertise-free high accuracy direct ring gage measurements with reduced total cost.

Incorporated with a high precision laser hologscale with a resolution of  $0.01\mu\text{m}$ , the Ring Master RM-120 directly measures the ring gage diameter between 6mm and 120mm without referring to otherwise required reference ring gages, efficiently and accurately. The measurement efficiency can be increased 100% over the conventional method where wringing gauge blocks is required.

- > The laser hologscale eliminates the need for a reference gauge block set and reference ring gages.
- > The line of measurement of the ring gage is on the axis of standard, meeting the Abbe's principle and ensuring higher measuring accuracy.
- > Stylus change is not required for the entire measuring range.
- > Enhanced repeatability and lower measuring force achieved with the air bearing on the stylus carriage guide.
- > Workpiece alignment is easy to perform with the specially designed table which is capable of translation, tilting, elevation, and 90 deg rotation. The model with analog meter will further facilitate workpiece translation and tilting.

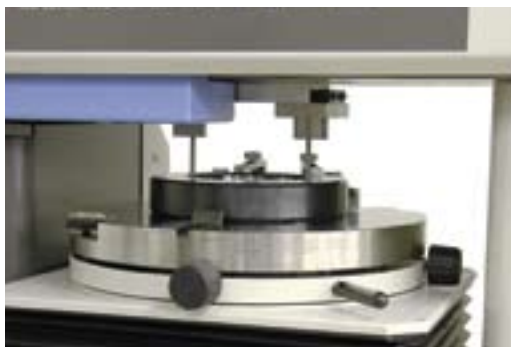

Standard counter type

## Specifications

Measuring range	ID: 6mm to 120mm
Workpiece size	OD: 20mm to 200mm Thickness: up to 40mm
Measurement	Differential measurement with two styli
Display resolution	$0.1\mu\text{m}$
Accuracy ( $\pm 2\sigma$ ) ( $20^\circ\text{C}$ )*	$\pm(0.3+5D/1000)\mu\text{m}$ , D=diameter to check (mm)
Repeatability ( $\pm 2\sigma$ )	$\pm 0.2\mu\text{m}$
Measuring force	Approx. 0.2N
Workpiece alignment	Centering range in XY plane: $\varnothing 2\text{mm}$ Tilting range about XY axis: $\pm 1/100$
Table elevation range	40mm during measurement Can down 50mm for workpiece loading/unloading
Air requirement	400kPa
Air consumption	Approx. 30L/min
Temperature	$20^\circ\text{C} \pm 0.5^\circ\text{C}$
Dimensions (WxDxH)	Standard counter type: 720x494x875mm Counter with analog meter type: 720x500x880mm



# Outside Micrometer Calibration

## Micrometer Inspection Gauge Block Set

Either set of gauge blocks can be used for measurement of outside micrometer errors, measurement surface flatness, and parallelism.

10-piece ceramic block set



### Specifications

Accuracy	Steel	Ceramic	Description
Grade 0	<b>516-111-10</b>	<b>516-116-10</b>	16-piece set with 12mm and 25mm thick optical parallels and Arkansas grinding stone
Grade 1	<b>516-112-10</b>	<b>516-162-10</b>	
Grade 2	<b>516-113-10</b>	<b>516-163-10</b>	
Grade 0	<b>516-103-10</b>	<b>516-152-10</b>	10-piece set
Grade 1	<b>516-101-10</b>	<b>516-153-10</b>	
Grade 2	—	<b>516-154-10</b>	
Grade K	<b>516-977-60</b>	—	
Grade 0	<b>516-978-10</b>	<b>516-378-10</b>	10-piece set with 12mm thick optical parallel
Grade 1	<b>516-979-10</b>	<b>516-379-10</b>	
Grade 2	<b>516-980-10</b>	<b>516-380-10</b>	
Grade 0	<b>516-106-10</b>	<b>516-156-10</b>	
Grade 1	<b>516-107-10</b>	<b>516-157-10</b>	
Grade 2	<b>516-108-10</b>	<b>516-158-10</b>	
Grade K	—	<b>516-164-60</b>	8-piece set
Grade 0	<b>516-115-10</b>	<b>516-165-10</b>	
Grade 1	<b>516-116-10</b>	<b>516-166-10</b>	
Grade 2	<b>516-117-10</b>	<b>516-167-10</b>	

## Optical Flats

These Optical Flats are used for inspecting the flatness of micrometer's or gauge block's measuring faces with high accuracy.



158-118

### Specifications

Flatness	Order No.	Diameter	Thickness
0.1µm	<b>158-118</b>	45mm	12mm
0.1µm	<b>158-120</b>	60mm	15mm
0.2µm	<b>158-117</b>	45mm	12mm
0.2µm	<b>158-119</b>	60mm	15mm

## Micrometer Standards

These micrometer standards are used for the zero point setting of outside micrometers (over 25mm).

- > Flatness of measuring faces: 0.3µm
- > Parallelism between measuring faces: 2µm
- > Standards for screw thread micrometer and V-anvil micrometer are also available.



167-108

### Specifications 167-103

Order No.	Length	Tolerance	Diameter
<b>167-101</b>	25mm	±1.5µm	6.35mm
<b>167-102</b>	50mm	±2.0µm	6.35mm
<b>167-103</b>	75mm	±2.5µm	6.35mm
<b>167-104</b>	100mm	±3.0µm	7.9mm
<b>167-105</b>	125mm	±3.5µm	7.9mm
<b>167-106</b>	150mm	±4.0µm	7.9mm
<b>167-107</b>	175mm	±4.5µm	7.9mm
<b>167-108</b>	200mm	±5.0µm	9.4mm
<b>167-109</b>	225mm	±5.5µm	9.4mm
<b>167-110</b>	250mm	±6.0µm	9.4mm
<b>167-111</b>	275mm	±6.5µm	9.4mm
<b>167-112</b>	300mm*	±7.0µm	9.4mm

\*Available up to 1000mm

## Optical Parallels

These Optical Parallels are designed to inspect parallelism and flatness of measuring faces of micrometers. Each set comprises 4 thicknesses, enabling the parallelism to be checked at every 1/4 rotation of the spindle.



157-903

### Specifications

Parallelism	Order No.	Flatness	Thickness	Diameter
0.2µm	<b>157-903</b>	0.2µm	12.00mm	30mm
			12.12mm	
			12.25mm	
			12.37mm	
0.2µm	<b>157-904</b>	0.2µm	25.00mm	30mm
			25.12mm	
			25.25mm	
			25.37mm	
			25.37mm	

# Inside Micrometer Calibration

## CERA Inside Micro-Checker

- > 10mm gauge blocks are arranged at 25mm intervals to efficiently check the zero point of a tubular inside micrometer.
- > This checker can be used to calibrate inside micrometers if attachment holders and gauge blocks are arranged in appropriate lengths.
- > For more information, refer to our General Catalog.

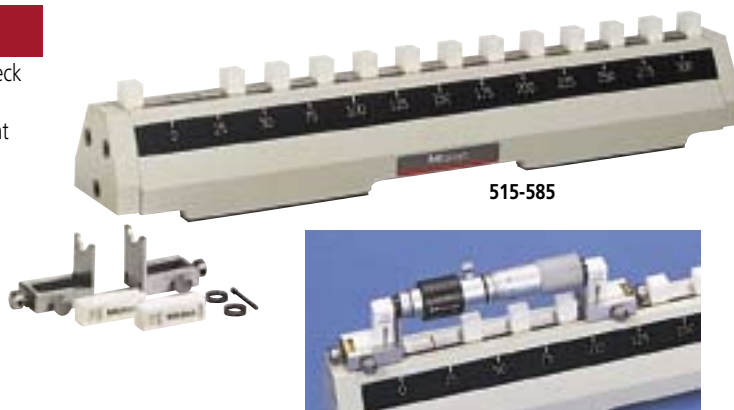

## Specifications

Range	Order No.	Accuracy
300mm	<b>515-585</b>	$\pm(1+L/150)\mu\text{m}$
600mm	<b>515-586</b>	L=Length to check (mm)

# Depth Micrometer Calibration

## Depth Micro-Checker

- > The Depth Micro-Checker is designed to efficiently check the zero point of a depth micrometer.
- > This checker can be used to calibrate depth micrometers if gauge blocks are arranged in appropriate lengths.
- > For more information, refer to Mitutoyo's General Catalog.



## Specifications

Range	Order No.	Accuracy
150mm	<b>515-570</b>	$\pm(1+L/150)\mu\text{m}$
300mm	<b>515-571</b>	L=Length to check (mm)

# Calipers/Height Gage Calibration

## CERA Caliper Checker

- > For calibration of the vernier, dial and digital calipers as well as height gages in vertical position.
- > For more information, refer to Mitutoyo's General Catalog.



## Specifications

Range	Order No.	Block pitch accuracy	Parallelism of blocks
300mm	<b>515-555</b>	$\pm 5\mu\text{m}$ for range up to 300mm	$\pm 2\mu\text{m}$ for range up to 300mm
600mm	<b>515-556</b>	$\pm 7\mu\text{m}$ for range up to 600mm	$\pm 4\mu\text{m}$ for range up to 600mm



# CMM/Machine Tool Calibration

## Check Masters

- > The Check Master is designed to check the accuracy of table movements of machine tools and calibrate CMMs.
- > This master gage can be used in either vertical and horizontal orientation.
- > Straight arrangement of 10mm block stack provides a calibration means at an interval of 20mm.

## Specifications

Range	Order No.	Block pitch accuracy	Parallelism of blocks
300mm	<b>515-720</b>	Up to 300mm: $\pm 2.5\mu\text{m}$	Up to 300mm: $1.2\mu\text{m}$
450mm	<b>515-721</b>		
600mm	<b>515-722</b>	300 - 600mm: $\pm 3.5\mu\text{m}$	300 - 600mm: $1.5\mu\text{m}$
1000mm	<b>515-723</b>	600 - 1000mm: $\pm 5.0\mu\text{m}$	600 - 1000mm: $2.0\mu\text{m}$
1500mm	<b>515-724</b>	1000 - 1500mm: $\pm 8.0\mu\text{m}$	1000 - 1500mm: $2.5\mu\text{m}$
300mm	<b>515-740*</b>	Up to 300mm: $\pm 1.2\mu\text{m}$	Up to 450mm: $1.0\mu\text{m}$
450mm	<b>515-741*</b>		
600mm	<b>515-742*</b>	300 - 600mm: $\pm 1.8\mu\text{m}$	450 - 1000mm: $1.5\mu\text{m}$
1000mm	<b>515-743*</b>	600 - 1000mm: $\pm 2.5\mu\text{m}$	1000 - 1500mm: $2.0\mu\text{m}$
1500mm	<b>515-744*</b>	1000 - 1500mm: $\pm 4.0\mu\text{m}$	

\*Available with CERAMIC block stack at request.



CMM calibration with Check Master No. 515-742



515-722

## Quadra-Square Master

Reference master for inspection of kinetic accuracy of machine tools, coordinate measuring machines and other precision measuring instruments where straightness or perpendicularity is critical.

- > Finished with the heritage ultra precision lapping technique developed in gauge block manufacture, the four faces on the Quadra-Square Master can serve as reference.
- > Straightness and perpendicularity of four faces are finished with closer tolerance of  $1\mu\text{m}/300\text{mm}$  or less. Perpendicularity of the reference face to the side face is within  $5\mu\text{m}$ .

## Specifications

Order No.	Dimensions (WxLxT)mm	Reference Faces perpendicularity/flatness	Side Faces perpendicularity/parallelism
<b>311-101</b>	80x100x25	$1\mu\text{m}/1\mu\text{m}$	$5\mu\text{m}/5\mu\text{m}$
<b>311-102</b>	160x200x25	$1\mu\text{m}/1\mu\text{m}$	$5\mu\text{m}/5\mu\text{m}$
<b>311-103</b>	250x300x25	$1\mu\text{m}/1\mu\text{m}$	$5\mu\text{m}/5\mu\text{m}$



## CERA Straight Master

This is a master gage used for the straightness inspection of each axis movement such as a CMM, machine tool, semiconductor related equipment and form measuring machine. An alminaceramic material is adopted to achieve the significant weight reduction compared with the conventional masters made from a stone or iron. The CERA Straight Master is high precision, high rigidity and easy to carry.

- > Alminaceramic made
- > 50mm/100" pitch gradation scales
- > Precision lapped measuring surface
- > Little secular change
- > Lightweight



## Specifications

Order No.	311-302	311-322	311-305	311-325	311-307	311-327	311-309	311-329
<b>Nominal length</b>	400mm	16"	700mm	28"	1000mm	40"	1300mm	50"
<b>Section form</b>	35x50mm/1.38"x1.97"				45mmx80mm/1.78"x3.15"			
<b>Straightness</b>	$0.3\mu\text{m}$	$12\mu\text{in}$	$0.5\mu\text{m}$	$20\mu\text{in}$	$1\mu\text{m}$	$40\mu\text{in}$	$1.5\mu\text{m}$	$60\mu\text{in}$
<b>Mass</b>	1.8kg/3.96lb		3kg/6.6lb		8kg/17.6lb		10kg/22lb	



# Dial Indicator/Dial Test Indicator/Bore Gage Calibration

## Calibration Tester (170, 521 Series)

- > 170 series dial gage tester is designed to calibrate measuring accuracy of 0.01mm reading gages; dial indicators (1mm, 5mm, 10mm and 20mm range), dial test indicators and bore gages.
- > 521 series calibration tester is specially designed to calibrate measuring accuracy of 0.001mm reading gages; dial indicators (1mm and 5mm range) and dial test indicators.  
The model **521-103** is also available for calibration of electronic micrometers.
- > For more information, refer to Mitutoyo's General Catalog.

## Specifications

Order No.	Graduation	Range	Accuracy
<b>170-102</b>	0.001mm	0 - 25mm	±2.0µm
<b>521-103</b>	0.0001mm	0 - 1mm	±0.2µm
<b>521-105</b>	0.0001mm	0 - 5mm	±0.8µm



521-103

170-102

## i-Checker

- > Mitutoyo brings you  $\pm(0.2+L/100)\mu\text{m} \times 1$  indication accuracy - the world's highest - for higher inspection reliability with various types of indicators and probes.
- \*1 When inspecting in vertical posture.
- > Now you can directly inspect an indicator with a stroke of up to 100mm. What's more, optional accessories let you inspect the dial test indicator, bore gage and lever-type inductive head each with a different form of support.
- > Adjustment of the measurement position is very easily accomplished because of semi-automatic measurement and full automatic measurement functions.
- > It is possible to create own simple inspection certificate.
- > It is possible to save inspection result as CSV file for reusable inspection result by any kind of software.
- > For more information, refer to Catalog No. E4217 "i-Checker".

## i-Checker main unit

Item	Contents
Measuring Range	100mm/4"
Resolution	0.02µm/8µin
Accuracy	vertical position $\pm(0.2+L/100)\mu\text{m}$ L=Arbitrary length lateral position $\pm(0.3+2L/100)\mu\text{m}$ L=Arbitrary length
Feed speed	4mm/sec (max.)
Drive method	Motor drive
Measuring Unit	Reflective-type metal linear encoder
Thermal expansion coefficient of measurement mode	$(8\pm 1) \times 10^{-6}/\text{K}$
Measurement method	Semiautomatic measurement Fully automatic measurement Digimatic Indicator with RS-232C output
Input data connector	Digimatic data input connector X1 Flat cable connector 10pin/equivalent to XG4-1301 from OMRON
Dimensions (WxDxH)	184x225x532mm/7.24"x8.86"x20.94"
Operating temperature range	20°C ±3°C
Operating humidity range	58%RH±15%RH (Only free of condensation)
Storage temperature range	-10°C to 50°C
Storage humidity range	5%RH to 90%RH (Only free of condensation)
Power supply	100VAC to 240VAC ±10%, 50/60Hz
Mass	20kg/441lbs

Order No.	Bush supplied	User's Manual	Calibration certificate
<b>170-302</b> ■	ø8	A4 size	—
<b>170-303</b> ■	ø3/8"	A4 size	—
<b>170-304</b> ■	ø8	8.5"x11" size	—
<b>170-305</b> ■	ø3/8"	8.5"x11" size	—
<b>170-302</b> ■ -01	ø8	A4 size	Supplied
<b>170-303</b> ■ -01	ø3/8"	A4 size	Supplied
<b>170-304</b> ■ -01	ø8	8.5"x11" size	Supplied
<b>170-305</b> ■ -01	ø3/8"	8.5"x11" size	Supplied

Note: To denote your AC line voltage fill the blank of order number with the following suffixes (e.g. **170-302A**). A for 120V, D for 220V, E for 240/220V. No suffix is required for 100V.



# Profile Projector/Measuring Microscope Calibration

## Standard Scale and Reading Scale for profile projectors (172 Series)

- > The Standard Scales are used for checking magnification accuracy of the profile projectors and microscopes.
- > The Reading Scales are specially designed for inspecting the magnified image of a standard scale on the projection screen.

### Specifications (Standard Scale)

Graduation	Range	Order No.	Accuracy
0.1mm	50mm	<b>172-116</b>	$\pm(3+5L/1000)\mu\text{m}$
0.1mm	80mm	<b>172-330</b>	$\pm(3+5L/1000)\mu\text{m}$

\*L=Length to check (mm)

### Specifications (Standard Scale)

Graduation	Range	Order No.	Accuracy*
0.5mm	200mm	<b>172-118</b>	$\pm(15+15L/1000)\mu\text{m}$
0.5mm	300mm	<b>172-161</b>	$\pm(15+15L/1000)\mu\text{m}$
0.5mm	600mm	<b>172-329</b>	$\pm(15+15L/1000)\mu\text{m}$

\*L=Length to check (mm)

## Standard Scale (182 Series)

- > High precision line standard manufactured under Mitutoyo's leading-edge Linear Scale production technology.
- > High accuracy is guaranteed to be used as a standard for calibrating graduated scales.
- > Made of low expansion glass.
- > Coefficient of thermal expansion:  $0.08 \times 10^{-6}/\text{K}$

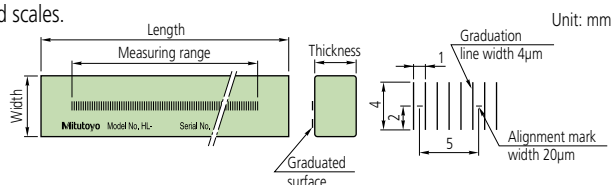

### Specifications

Range	Order No.	Graduation		Accuracy (at 20°C)	Dimensions		
		Pitch	Thickness		Length	Width	Thickness
250mm	<b>182-501</b>	1mm	4µm	0.75µm	280mm	20mm	10mm
500mm	<b>182-502</b>	1mm	4µm	1µm	530mm	30mm	20mm

## Working Standard Scale (182 Series)

- > High precision line standard manufactured under Mitutoyo's leading-edge Linear Scale production technology.
- > Ideal for checking the table feeding accuracy of measuring equipment and the semiconductor production equipment.
- > Made of sodium glass.
- > Coefficient of thermal expansion:  $(8 \pm 1) \times 10^{-6}/\text{K}$

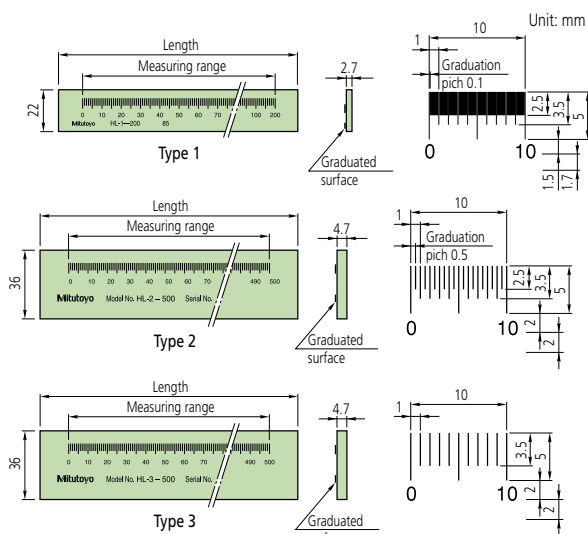

### Specifications

Range	Order No.	Graduation		Accuracy (at 20°C)	Length	Type
		Pitch	Thickness			
50mm	<b>182-511</b>	0.1mm	20µm	1.6µm	75mm	Type 1
100mm	<b>182-512</b>	0.1mm	20µm	1.7µm	125mm	Type 1
150mm	<b>182-513</b>	0.1mm	20µm	1.8µm	175mm	Type 1
200mm	<b>182-514</b>	0.1mm	20µm	1.9µm	225mm	Type 1
100mm	<b>182-521</b>	0.5mm	50µm	1.7µm	130mm	Type 2
200mm	<b>182-522</b>	0.5mm	50µm	1.9µm	230mm	Type 2
300mm	<b>182-523</b>	0.5mm	50µm	2.1µm	330mm	Type 2
400mm	<b>182-524</b>	0.5mm	50µm	2.3µm	430mm	Type 2
500mm	<b>182-525</b>	0.5mm	50µm	2.5µm	530mm	Type 2
250mm	<b>182-531</b>	1mm	100µm	2.0µm	280mm	Type 3
500mm	<b>182-532</b>	1mm	100µm	2.5µm	530mm	Type 3
750mm	<b>182-533</b>	1mm	100µm	3.0µm	780mm	Type 3
1000mm	<b>182-534</b>	1mm	100µm	3.5µm	1030mm	Type 3



# Snap Gage (C-gage) Calibration

## Snap Gage Checker

The Snap Gage Checker is capable of inspecting the snap gage of sizes up to 320mm quickly and accurately with resolution down to 0.0001mm.



## Specifications

Order No.	515-611■
Resolution	0.0001mm
Range	20 - 320mm
Block travel	100mm
Block pitch accuracy	±0.001mm
Parallelism of blocks	0.001mm
Block feeding error	±0.002mm
Measuring force	4 - 10N (available)

Note: To denote your AC line voltage fill the blank of order number with the following suffixes (e.g. **515-611A**). A for 120V, D for 220V, E for 240/220V. No suffix is required for 100V.

# Height Measurement Standard/Surface Plate

## Height Masters

- > The Height Master is used as a reference gage of the height measurement.
- > This master gage features the staggered arrangement of block stack which has two measuring faces on the same level, one facing up and the other facing down.
- > Riser blocks (blocks for increasing the height) are also available.
- > For more information, refer to Mitutoyo's General Catalog.



## Specifications

Range	Order No.	Resolution	Description
5 - 310mm	<b>515-322</b>	0.001mm	Standard type
10 - 310mm	<b>515-354</b>	0.001mm	Digital type
10 - 460mm	<b>515-356</b>	0.001mm	Digital type
10 - 610mm	<b>515-358</b>	0.001mm	Digital type
5 - 310mm	<b>515-341■</b>	0.0001mm	Digital type

Note: To denote your AC line voltage fill the blank of order number with the following suffixes (e.g. **515-341A**). A for 120V, D for 220V, E for 240/220V. No suffix is required for 100V.

Order No.	515-322	515-354 515-356	515-358	515-341
Block pitch accuracy	Up to 300mm: ±1.5µm 300 - 450mm: — 450 - 600mm: —	±1.5µm ±2.5µm —	±1.5µm ±2.5µm ±3.5µm	±0.5µm — —
Parallelism of blocks	Up to 300mm: 1.0µm 300 - 600mm: —	2.0µm 2.5µm	2.0µm 2.5µm	0.5µm —
Block feeding error	±1.0µm	±2.0µm	±2.5µm	±0.5µm

## Graplate (Granite Surface Plate)

This is used for a reference surface plate in the height and perpendicularity measurements and layout work.



Dimensions (WxDxH)mm	Order No.			Flatness (mm)			Steel stands (optional)		
	00 grade	0 grade	1 grade	00 grade	0 grade	1 grade	Order No.	h (adjustable)	Remark
300x300x100	<b>517-401-4</b>	<b>517-301-4</b>	<b>517-101-4</b>	0.002	0.003	0.005	—	—	—
450x300x100	<b>517-411-4</b>	<b>517-311-4</b>	<b>517-111-4</b>	0.002	0.003	0.006	—	—	—
600x450x100	<b>517-414-4</b>	<b>517-314-4</b>	<b>517-114-4</b>	0.0025	0.004	0.008	<b>517-203/203R*/203CR**</b>	755 - 780mm	With levelling bolt
600x600x130	<b>517-403-4</b>	<b>517-303-4</b>	<b>517-103-4</b>	0.0025	0.005	0.008	<b>517-204/204R*/204CR**</b>	785 - 810mm	With levelling bolt
750x500x130	<b>517-405-4</b>	<b>517-305-4</b>	<b>517-105-4</b>	0.003	0.005	0.009	<b>517-205/205R*/205CR**</b>	785 - 810mm	With levelling bolt
1000x750x150	<b>517-407-4</b>	<b>517-307-4</b>	<b>517-107-4</b>	0.003	0.007	0.012	<b>517-206/206R*/206CR**</b>	755 - 780mm	With levelling bolt
1000x1000x150	<b>517-409-4</b>	<b>517-309-4</b>	<b>517-109-4</b>	0.0035	0.008	0.013	<b>517-207/207R*/207CR**</b>	735 - 775mm	With levelling bolt
1500x1000x200	<b>517-413-4</b>	<b>517-313-4</b>	<b>517-113-4</b>	0.004	0.008	0.016	<b>517-208/208R*/208CR**</b>	735 - 775mm	With levelling bolt
2000x1000x250	<b>517-410-4</b>	<b>517-310-4</b>	<b>517-110-4</b>	0.0045	0.010	0.019	<b>517-209/209R*/209CR**</b>	735 - 775mm	With levelling bolt
2000x1500x300	<b>517-416-4</b>	<b>517-316-4</b>	<b>517-116-4</b>	0.005	0.110	0.020	<b>517-210/210R*/210CR**</b>	735 - 775mm	With levelling bolt
2000x2000x300	<b>517-417-4</b>	<b>517-317-4</b>	<b>517-117-4</b>	0.0055	0.011	0.022	<b>O6AAY174</b>	700 - 706mm	—
3000x1500x400	<b>517-418-4</b>	<b>517-318-4</b>	<b>517-118-4</b>	0.0065	0.013	0.025	<b>O6AAY175</b>	700 - 706mm	—
3000x2000x500	<b>517-419-4</b>	<b>517-319-4</b>	<b>517-119-4</b>	0.007	0.014	0.027	<b>O6AAY176</b>	700 - 706mm	—

\*with drop prevention device

\*\*with caster wheel

## Calibration Standards/ Instruments and Accredited Calibration Services

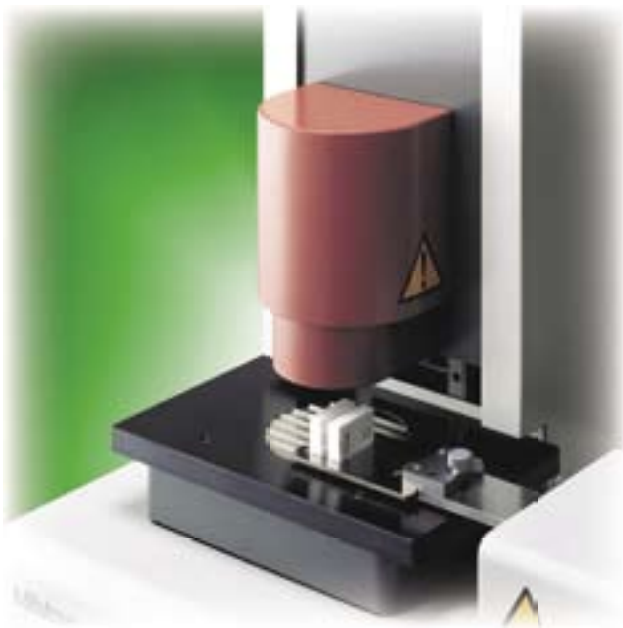

Our products are classed as regulated items under Japanese Foreign Exchange and Foreign Trade Law. Please consult us in advance if you wish to export our products to any other country. If the purchased product is exported, even though it is not a regulated item (Catch-All controls item), the customer service available for that product may be affected. If you have any questions, please consult your local Mitutoyo sales office.

Coordinate Measuring Machines

Vision Measuring Systems

Form Measurement

Optical Measuring

Sensor Systems

Test Equipment and  
Seismometers

Digital Scale and DRO Systems

Small Tool Instruments and  
Data Management

Note: All information regarding our products, and in particular the illustrations, drawings, dimensional and performance data contained in this pamphlet, as well as other technical data are to be regarded as approximate average values. We therefore reserve the right to make changes to the corresponding designs, dimensions and weights. The stated standards, similar technical regulations, descriptions and illustrations of the products were valid at the time of printing. Only quotations submitted by ourselves may be regarded as definitive.

**Our products are classed as regulated items under Japanese Foreign Exchange and Foreign Trade Law. Please consult us in advance if you wish to export our products to any other country. If the purchased product is exported, even though it is not a regulated item (Catch-All controls item), the customer service available for that product may be affected. If you have any questions, please consult your local Mitutoyo sales office.**

### Mitutoyo Corporation

20-1, Sakado 1-Chome,  
Takatsu-ku, Kawasaki-shi,  
Kanagawa 213-8533, Japan

T +81 (0) 44 813-8230

F +81 (0) 44 813-8231

<http://www.mitutoyo.co.jp>

# Mitutoyo