







HARDNESS TESTING MACHINES

PRE 1405



HARDNESS TESTING MACHINES

CONTENTS

Page		Page	
3	Introduction	34	Rockwell hardness testing machines: HR-500Series
4	Hardness testing machine lineup	37	Optional accessories
5	Types of hardness and selection criteria for hardness testing machines	39	Data processing software for hardness testing machines
 7	Micro Vickers hardness testing machines : HM-200 and HM-100 Series	 41	Rebound type portable hardness tester: Hardmatic HH-411
8	Micro Vickers hardness testing machines : HM-200 Series	 44	Durometers for sponges, rubber and plastics: Hardmatic HH-300 Series
19	Micro Vickers hardness testing machines : HM-100 Series	50	Related information and materials
21	Optional accessories	50	Hardness basics
 23	Micro surface material characteristics evaluation system : MZT-500 Series	51	Hardness definitions and types
 26	Vickers hardness testing machines : HV-100 Series and AVK-C0	52	Relationship between specimen hardness and minimum thickness
27	Vickers hardness testing machines: HV-100 Series	52	Types of Rockwell hardness
28	Vickers hardness testing machines: AVK-C0	52	Types of Rockwell Superficial hardness
29	System set-ups	53	Hardness conversion table
30	Optional accessories	54	Related standards
 31	Rockwell hardness testing machines HR Series		
32	Rockwell hardness testing machines: HR-100 to HR-400 Series		

INDEX

Order No.	Model	Page
810-124,125	HM-101,102	19~20
810-160	AVK-C0	28
810-163,165	HV-112,114	27
810-202,203,204	HR-521,522,523	34~36
810-299	HH-411	41~43
810-312-11	VLPAK2000	29
810-314-11	AT-400	29

Order No.	Model	Page
810-400,405,403,408	HM-210,220	8~18
810-727,728	AAV-503,504	29
810-813,814	MZT-500L,500P	23~25
810-959	HM-103	20
810-981,985	HV-113,115	27
811-329,330 331,332,333,334 335,336,337,338	HH-329,330 331,332,333,334 335,336,337,338	44~49
963-210, 220, 231, 240, 41	HR-110MR, HR-210MR, HR-320MS, HR-430MR, HR-430MS	32~33

Introduction

Hardness testing machine lineup

Among the many types of material testing equipment, hardness testing machines provide the simplest and most economical testing methods and they play a vital role in research through to production and commercial transactions. Mitutoyo meets diverse needs by offering a broad lineup of efficient machines for testing the hardness of many kinds materials ranging from hard metals to soft plastics and rubber.

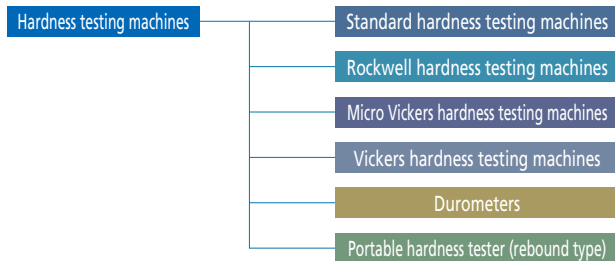

CE compliance

The products in this brochure are safe designs conforming to low voltage, EMC and machinery directives of the EU. (Excludes some products.)



Overview of SHT Series standard hardness testing machines



SHT Series standard hardness testing machines possess all the characteristics required to serve as a benchmark for hardness testing machines, namely high accuracy, stability, reproducibility and quality. SHT Series machines are ideal for use as specified sub-primary or secondary standards, for example as specified standard instruments, under the domestic traceability framework currently being reviewed in Japan, as well as verification standards for general users. The SHT Series lineup comprises four standard hardness testing machines supporting the four most important types of hardness measurement in the industrial sector—Rockwell hardness standard testing machine SHT-31, Vickers hardness standard testing machine SHT-41, Brinell hardness standard testing machine SHT-5, and Shore hardness standard testing machine SHT-6. All four models were adopted by Korea's metrology institute, the Korea Research Institute of Standards and Science (KRISS), in 1997. In 2001, Taiwanese metrology institute the Center for Measurement Standards of the Industrial Technology Research Institute (ITRI) adopted the SHT-41. And in 2003, the National Institute of Metrology (Thailand) (NIMT) adopted SHT-31, SHT-41 and SHT-6. In Japan, the SHT-31 delivered to the National Research Laboratory of Metrology of the Agency of Industrial Science and Technology, or AIST) was made a specified standard instrument in 1998 under Ministry of International Trade and Industry (MITI) Public Notice No. 587. And in March 2001, the Vickers hardness standard testing machine (SHT-41) held by AIST was made a specified standard instrument alongside the Rockwell hardness standard testing machine (SHT-32) under Ministry of Economy, Trade and Industry (METI) Public Notice No. 210. SHT Series models are living up to their name as standard hardness testing machines.

Rockwell hardness standard testing machine SHT-31

(main unit and control panel, shown with optional accessories)



Brinell hardness standard testing machine SHT-5



Vickers hardness standard testing machine SHT-41



Shore hardness standard testing machine SHT-6





Hardness testing machine lineup

Hardness testing machine icons



Standard hardness testing machine



Micro Vickers hardness testing machine



Micro surface material property evaluation system



Vickers hardness testing machine



Rockwell hardness testing machine



Portable hardness tester

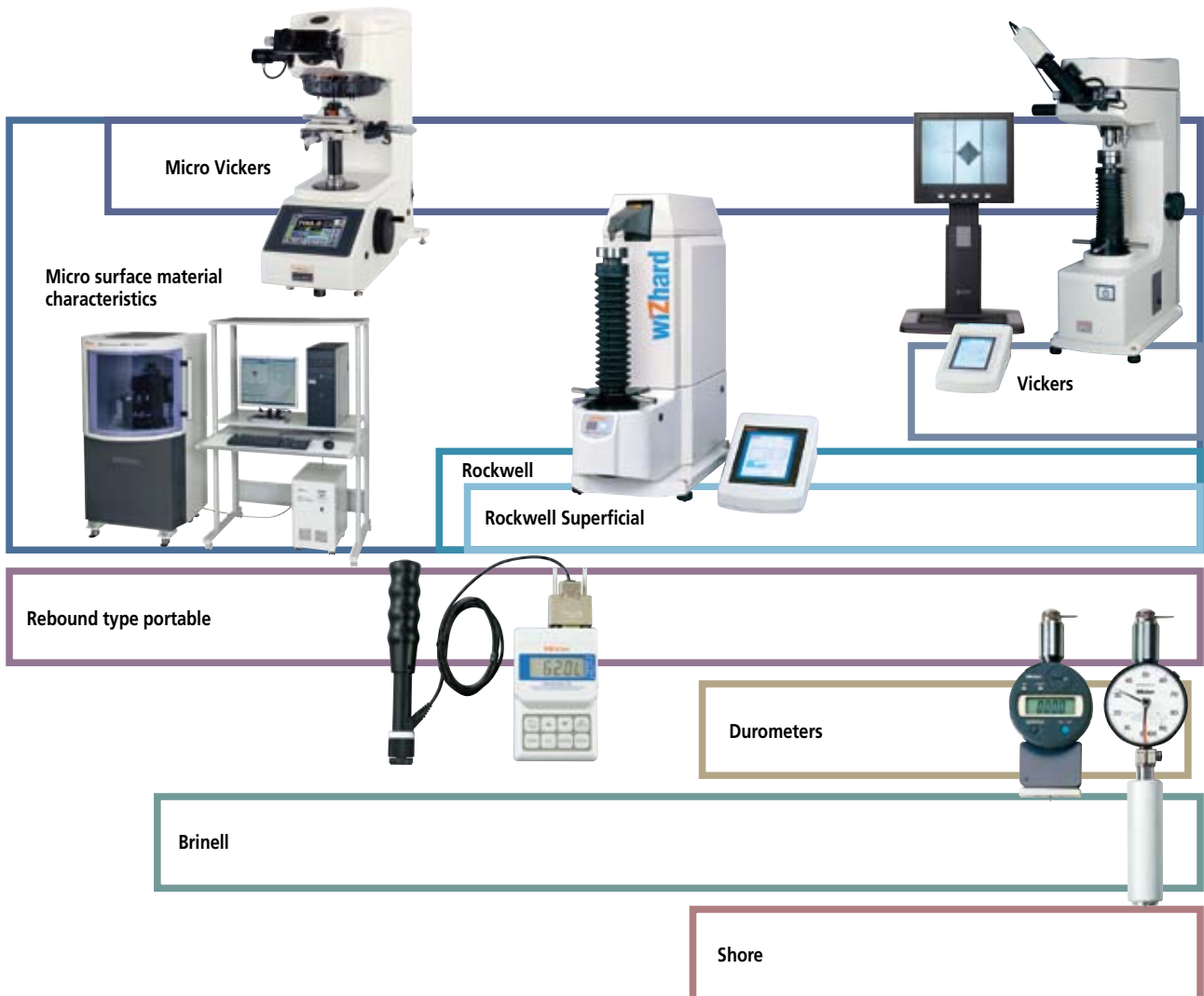

Types of hardness test and selection criteria for hardness testing machines

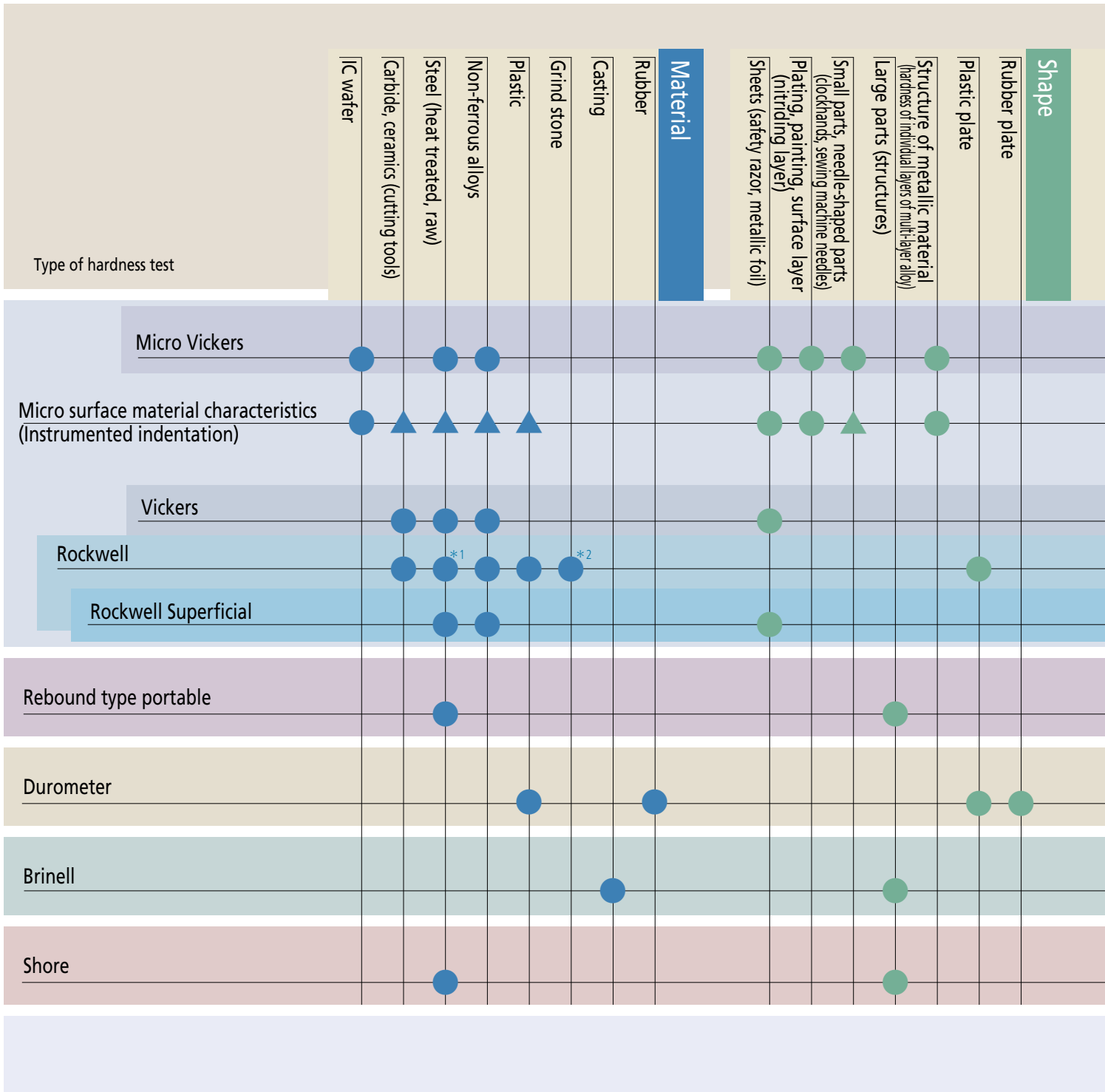

● : Suitable ▲ : Fairly suitable *1 : A scale *2 : H scale *3 : Test force 2.942N 9.807N *4 : Test force 0.9807N 9.807N *5 : Test force 2.942N or more



	Material strength	Heat treatment process	Hardened layer depth	Decarburization layer depth	Flame/high-frequency quenching hardened layer depth	Hardenability test	Maximum hardness of weld	Hardness of weld	High temperature hardness (high temperature properties, hot workability)	Fracture toughness (ceramics)	Inspection, judgment			
	▲	●	●	● ^{*3}	● ^{*4}	● ^{*5}				●		HM-210, etc.	Micro Vickers Hardness Testing Machines HM-200 Series, HM-100 Series	7
	●											MZT-500L,500P	Micro surface material characteristics evaluation system MZT-500 Series	23
	●	●	●	● ^{*6}	● ^{*6}	●	●	●	● ^{*7}	● ^{*8}	●	HV-112, HV-114, etc.	Vickers hardness testing machine AVK-CO, HV-100 Series	26
	●	●			● ^{*9}	● ^{*9}		●	● ^{*10}			HR-110MR, HR-210MR HR-430MR, HR-521, etc.	Rockwell hardness testing machine HR Series	31
	●	●	●	● ^{*11}								HR-320MS,HR-430MS,HR-521, etc.	Hardmatic HH-411 (Rebound type portable hardness tester)	41
	▲	▲										HH-411	Hardmatic HH-300 Series (Durometer)	44
												HH-329, etc.		
	▲	▲												
													Related information and materials	50

*6 : Test force 9.807N *7 : Test force 98.07N *8 : Test force 294.2N *9 : C scale *10 : B, C scale *11 : 15N, 30N scale

Micro Vickers hardness testing machines

HM-100/HM-200 Series

The ideal series for Vickers hardness testing on a microscopic scale. Ideal for micro-level quality control and mechanical property evaluations covering thin coating or plating layers, the small surfaces of IC bonding pads, crystal grains within metallic structures, and cross-sectional hardenability evaluation after heat treatment.

High-spec models

**810-400
HM-210**

High-spec digital model with arbitrary test force setting, auto turret and color LCD touch-screen control unit



Test force range: 98.07-9807mN

**810-405
HM-220**

High-spec digital model with arbitrary test force setting, auto turret and color LCD touch-screen control unit

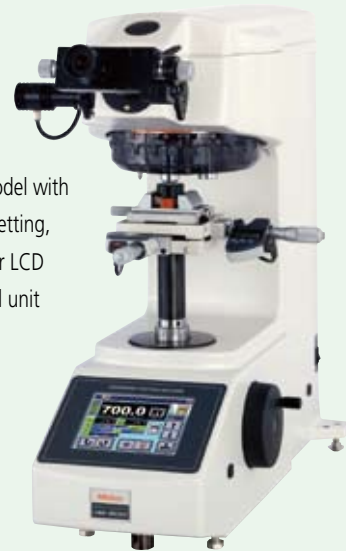

Test force range: 0.4903-19610mN

Economy models

**810-124
HM-101**

Economy analog model



Test force range: 98.07-9807mN

**810-125
HM-102**

Basic digital model



Test force range: 98.07-9807mN

HM-200 Series features

Equipped both with the latest optical system ideal for measuring the dimensions of indentation images and a test-force loading device that lets you freely set the desired test force. The HM-200 series is ideal for quality control and mechanical characteristic evaluation using Vickers hardness testing of small areas.

System A

HM-210A/HM-220A

All-in-one model with simple touch-panel operation

Features

- Touch-panel operation
- Measurement of indentation dimensions using a measuring microscope
- Positioning using a manual XY stage



System C

HM-210C/HM-220C

Improves work efficiency for multi-point testing

Features

- Operated using AVPAK-20
- Automatic indentation reading
- Automatic positioning with motorized XY stage

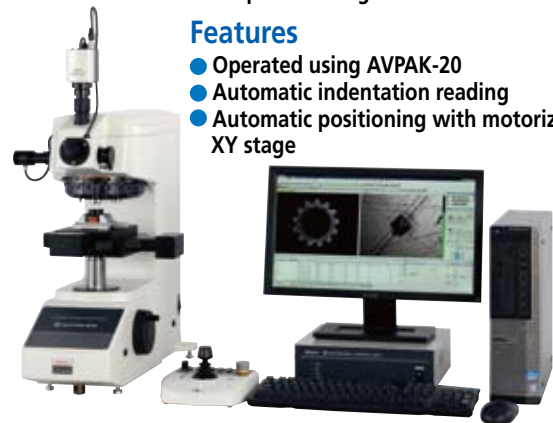

System B

HM-210B/HM-220B

Automatic dimensions by AVPAK-20 eliminates indentation measurement errors.

Features

- Operation using AVPAK-20
- Automatic measurement of indentations
- Positioning using a manual XY stage

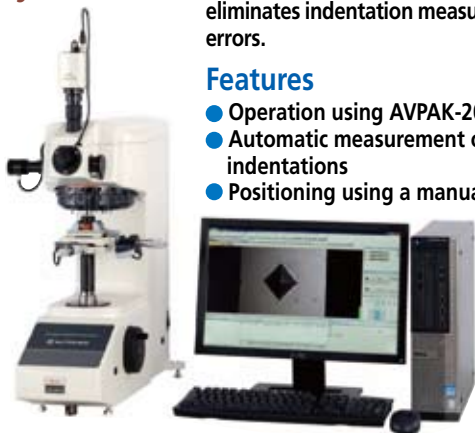

System D



HM-210D/HM-220D

Top-end model with autofocus

Features

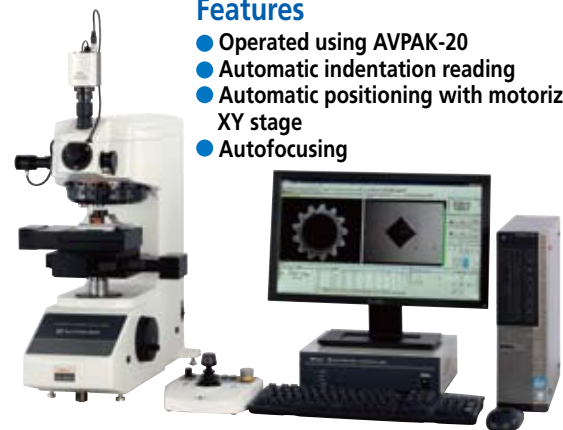
- Operated using AVPAK-20
- Automatic indentation reading
- Automatic positioning with motorized XY stage
- Autofocusing

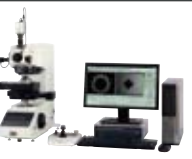

	System A	System B	System C	System D
Functions				
Focusing	Manual	Manual	Manual	Auto
Testing action	Single point	Single point	Programmed multi-point	Programmed multi-point
Test-point positioning	Manual XY stage	Manual XY stage	Motorized XY stage	Motorized XY stage
Measuring indentations	Measuring microscope	Automatic (AVPAK-20)	Automatic (AVPAK-20)	Automatic (AVPAK-20)
Camera (for observing and measuring indentations)	Monochrome, 300,000 pixels*	Color, 3 million pixels	Color, 3 million pixels	Color, 3 million pixels
Operating the main unit	Touch panel	PC (AVPAK-20)	PC (AVPAK-20)	PC (AVPAK-20)

*When a video camera unit is used (pixel count of the camera itself: 380,000)

HM-210/220 Manual model main unit

High-functionality model for System A

Measuring microscope

Microscope for measuring indentation dimensions.
Integrated 10X eyepiece (810-354 video camera unit can be installed)

LED illumination unit

An LED illumination unit offers a long service life and low power consumption. LED illumination reduces the time lost during the light bulb replacement required with conventional illumination units.

Automatic turret mechanism

The positions of the indenter and the objective lens can be automatically switched using touch panel operation (can also be manually switched). Up to four objectives can be installed.
Up to two indenter shaft units can be installed.

Interfacing to external instruments

Provided with a wide variety of interfaces to suit almost any purpose. Test results can be printed on a printer or output to a PC.

- USB 2.0 interface (for data communication)
For PC (EXPAK V.6)
- Digimatic interface
For DP-1VR, U-WAVE, and USB-ITN
- Serial interface For DPU-414

Wide range of test force

Use of an electromagnetic method makes it possible to set the desired test force practically anywhere between 0.4903 mN and 19610 mN. (HM-220)

Objective lenses provide a long working distance

Six MH Plan objectives are available. The 10X, 20X, 50X, and 100X types are used when measuring indentations, and the 2X and 5X for widefield observation tasks.

Manual XY stage unit with digital micrometer head

During test-site positioning, the positional information is displayed digitally and can also be displayed on the touch panel display controller. XY range of 25×25 mm or 50×50 mm can be selected.

Color Touch-panel controller

Touch-panel operations for controlling hardness testing provide a full suite of basic functions necessary for hardness testing, a function for converting the hardness value into various types of hardness scale, and a statistical calculation function



Video camera unit 810-354 (Can be installed in the manual model main unit)

CCD camera and 8.4-inch TFT monitor
Enables observation and measurement of indentations at high magnification, thereby reducing operator error



High-functionality model for Systems B, C and D

Measuring microscope (Can be installed as an option)

Enables magnified observation and measurement of indentations.
 (The vision unit integrated in the system model main unit and the measuring microscope cannot be simultaneously used for observation.)

LED illumination unit

An LED illumination unit offers a long service life and low power consumption. LED illumination reduces the time lost during the light bulb replacement required with conventional illumination units.

Automatic turret mechanism

The positions of the indenter and the objective lens can be automatically switched from a PC (AVPAK-20) (can also be manually switched).
 Up to four objectives can be installed.
 Up to two indenter shaft units can be installed.

Auto focus stage (System D)

For fast, high-precision autofocusing. Enables 3x faster autofocusing than earlier models (HM-221 AFU unit: narrow range autofocus).

- Repeatability positioning accuracy: 0.2μm
- Min. feed: 0.1μm
- Travel range: ±0.7mm
- Max. speed: 1mm/s

Vision unit

USB color mega-pixel camera. A 3-million pixel, 1/2-inch color USB camera is used for the system model.

Wide range of test force

Use of an electromagnetic method makes it possible to set the desired test force practically anywhere between 0.4903 mN and 19610 mN. (HM-220)

Objective lenses provide a long working distance

Six MH Plan objectives are available. The 10X, 20X, 50X, and 100X types are used when measuring indentations, and the 2X and 5X for widefield observation tasks.
 2X and 5X for wide-field observation

Motorized stage (Systems C and D)

Test position controllable using AVPAK-20 or the Remote Control Box. AVPAK-20 can be used to execute patterns for multi-point testing. Use of a ball screw improves durability, allowing 4x faster movement than earlier models.

- Repeatability positioning accuracy: 2μm
- Min. feed: 1μm
- Max. speed: 25mm/s
- XY range: Choice of 25x25 mm or 50x50 mm



Pictured main unit: System D

USB 2.0 connection



AVPAK-20 software for automatic hardness testing systems

Software that supports control, testing, and report creation related to hardness testing. Supports parameter setting and automatic measurement.

High-functionality PC and TFT monitor

Compatible with Windows 7 Professional 32-bit OS. Supports a wide-screen TFT and provides improved operability.

HM-200 Series

AVPAK-20 software for controlling Systems B, C and D

Screen layout for control, testing status, and result display can be changed freely.

Graphic view (of stored images)

For displaying the entire specimen and checking the pattern positioning. The digital zoom function can be used to easily magnify and check the indentation site.

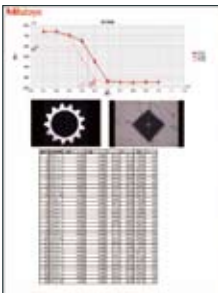

Layout view

Photos from individual views, graphs, tables, etc., can be laid out freely to help with report creation.

Part program

Automatically records the sequence of operations in a test. To repeat the same test, the part program can be called up for repeated execution.

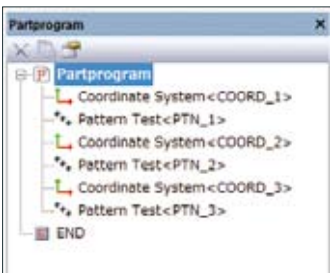

Parts manager

Stitching Auto trace Contour detection Pattern creation Pattern pasting

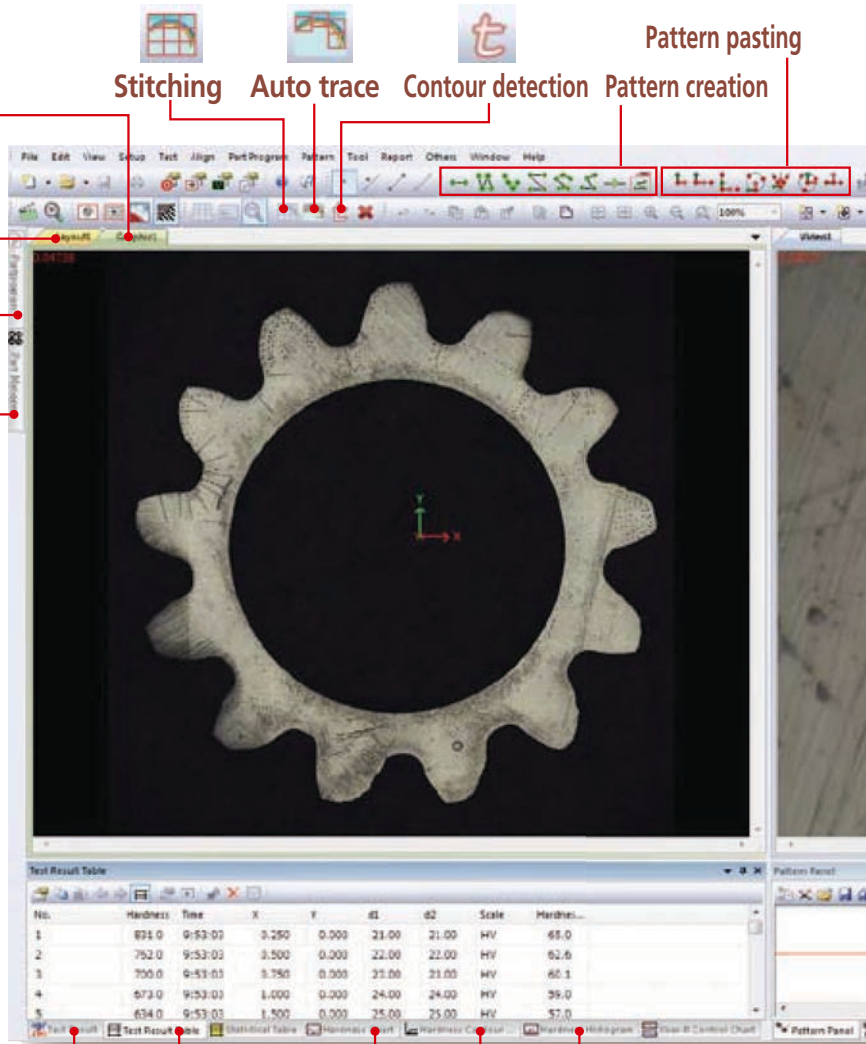

Test result list view

Hardness distribution diagram

Test result view

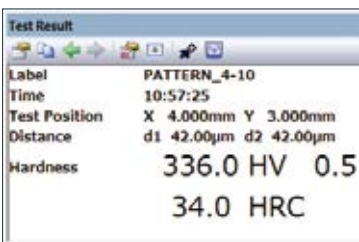

Hardness curve graph



Video view (live image)
Indentation image display
 Small indentations can be observed using the digital zoom function.

Contrast level meter
 Stable focusing can be easily achieved by anyone.

Counter
 Displays the stage's current coordinates.

Property panel

Test control
 Controls test actions such as wide- or narrow-range auto-focusing and measurement of indentations.

Turret control
 Switches the objective lens and indenter in and out of the test position

Illumination control
 Controls the illumination in 100 steps

Stage control
 Used to move the motorized XY stage and AF stage. (Systems C and D only)

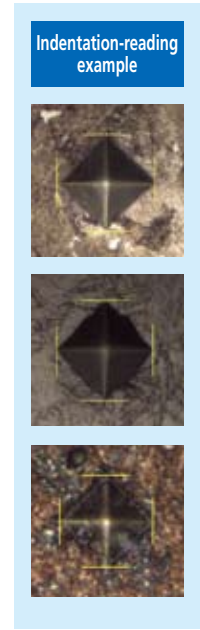

Pattern panel

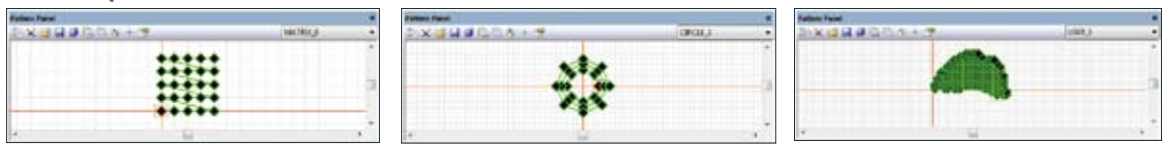

Frequency distribution graph

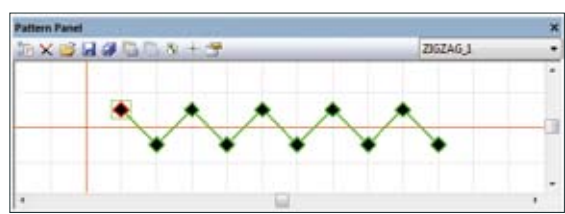
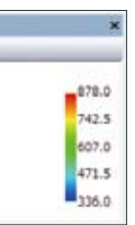

HM-200 Series AVPAK-20 software for controlling Systems B, C and D

New functions

Stitching
Takes images of an entire rectangular field from the moving stage then combines the images.



Auto trace
Automatically traces the shape of the sample. Takes images as the stage moves along the outer contours of the specimen then combines the images.



Contour detection
Detects the outline of the workpiece from combined images.



Pattern creation
This tool supports the creation of test patterns such as straight lines, zigzag lines, and teaching patterns.



Pattern pasting
This tool supports the pasting of created test patterns. It adjusts the origin, direction, etc., to paste a pattern.

Remote Control Box

Assists operation using AVPAK-20. Besides control of the motorized XY stage, the Remote Control Box can be used for turret switching, XY stage speed control and single-point testing. (Systems C and D)



There are four speeds to choose from for stage control using the joystick—Step, Low, Middle, and High.

Dimensions: 177 x 176 x 49mm (WxDxH)
Mass: 1kg

Handling of multiple specimens

Part program and Parts Manager functions support testing of multiple and irregular specimens.

Multi-specimen testing
Executes different part programs for each irregular specimen



Parts Manager
Executes a common part program for specimens having the same shape



Reading of indentations

Improvement in image-processing performance has improved the indentation measurement function.



*measurement accuracy varies according to conditions.

Indentation depth display

Displays the indentation depth of the diamond indenter while the testing force is being applied. (Reference value)



Property panel

Used for setting the test conditions such as the test force and duration time, as well as the indentation measurement condition.

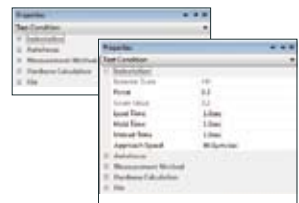

Navigation function

When the test position is being moved during multi-point testing, this function guides the travel of the XY fine adjustment manual stage to the next position. (System B)



HM-200 Series Touch-panel for controlling Systems A

Touch-panel control screen

Easy-to-understand graphic display enables intuitive operation. Functions for converting values and compensating for curved surfaces, as well as a test condition guiding function are all provided as standard features.
(Installed in the manual model main unit)

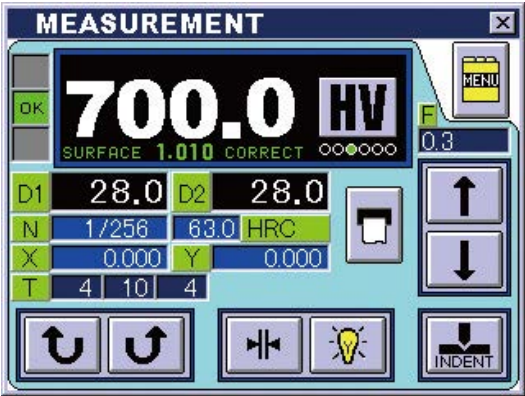

Displays test conditions and test results.

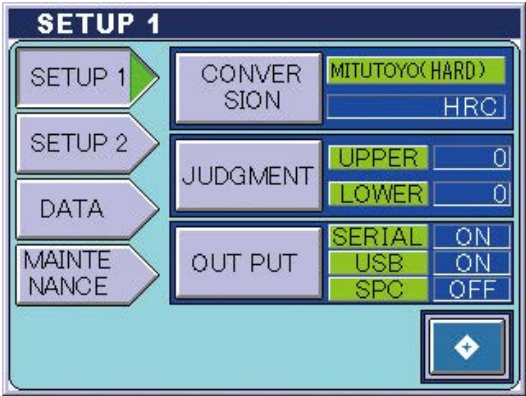

Used for selecting a conversion scale, entering a setting for Pass/Fail determination, and specifying external output.

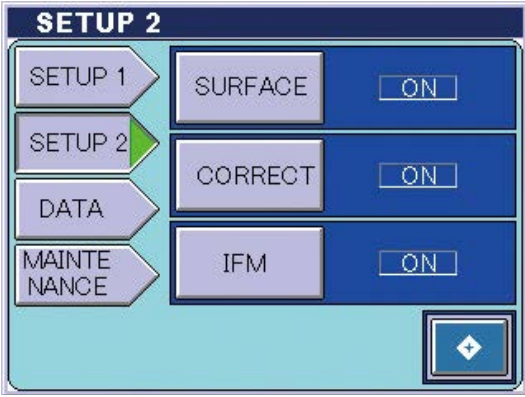

Used for selecting a conversion scale, entering a setting for Pass/Fail determination, and specifying external output.

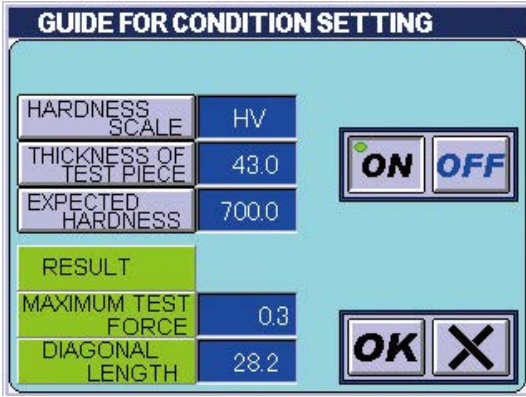

By entering the specimen thickness and the presumed hardness, you can set a test force that satisfies the JIS conditions.



In addition to the test force duration time, you can specify loading and unloading testing actions.

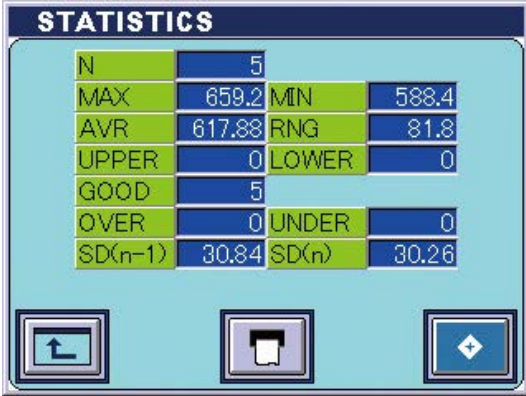

You can check the test results in a statistical list.

HM-200 Series System outline drawings

System A

Unit: mm

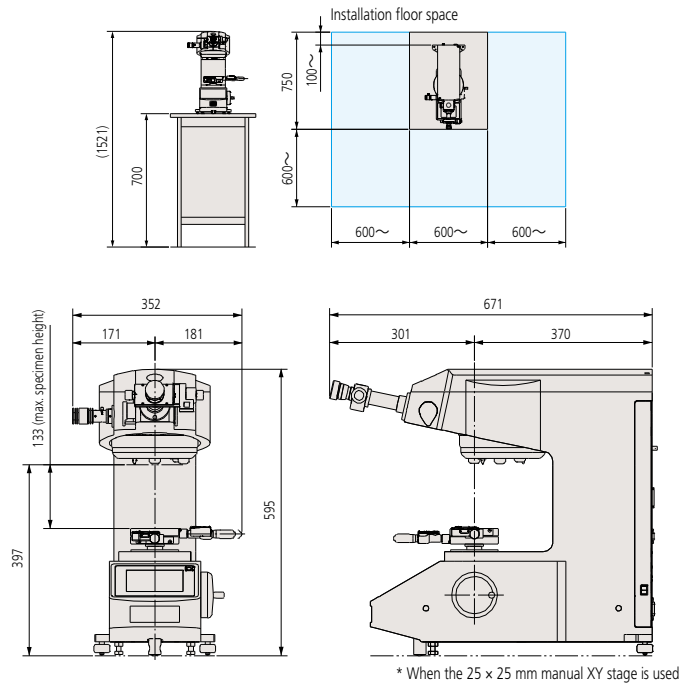

System D

Unit: mm

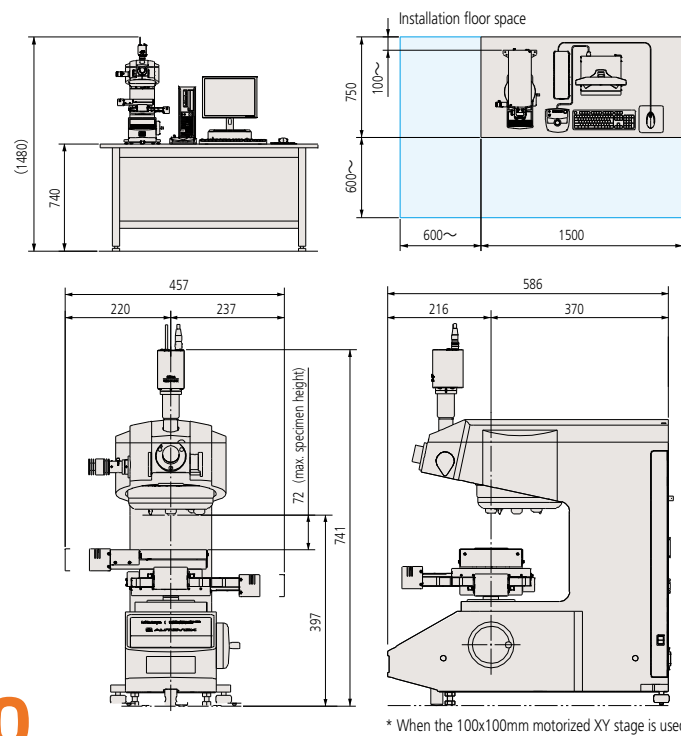



System configurations

Parameter	Order No.	Item	System A	System B	System C	System D	Details	Notes
Main unit	810-400*	HM-210 manual model main unit	○		×		Standard test force, microscope with a 50X lens	
	810-405*	HM-220 manual model main unit	○		×		Low test force, microscope with a 50X lens	
	810-403*	HM-210 system model main unit	×		○		Standard test force, 50X lens	No measuring microscope, No touch panel
	810-408*	HM-220 system model main unit	×		○		Low test force, 50X lens	No measuring microscope, No touch panel
Factory installed options	11AAC104	Objective lens unit 2X			○		Objective lens, with lens holder	Up to three additional lenses can be selected (maximum of four lenses can be installed in the main unit)
	11AAC105	Objective lens unit 5X			○		Objective lens, with lens holder	
	11AAC106	Objective lens unit 10X			○		Objective lens, with lens holder	
	11AAC107	Objective lens unit 20X			○		Objective lens, with lens holder	
	11AAC108	Objective lens unit 100X			○		Objective lens, with lens holder	
	11AAC109	Indenter shaft unit for HM-210			○		With 19BAA061 knoop indenter	Double-indenter specification
	11AAC110	Indenter shaft unit for HM-220			○		With 19BAA062 knoop indenter	Double-indenter specification
	11AAC129	Measuring microscope (which can be added)	×		○			Cannot be used simultaneously with the VISION UNIT
Essential options	810-354*	Video camera unit	○		△		Monochrome 300000-pixel camera, 8.4-inch TFT, with a stand	△ : Installation requires a measuring microscope. Provided on a special order basis
	810-421*	Motorized XY stage unit 50x50				●		
	810-422*	Motorized XY stage unit 100x100	×			●		
	810-420	Manual XY stage unit 25x25		●		×		
	810-423	Manual XY stage unit 50x50		●		×		
	810-424	Manual XY stage unit 1" x1"		●		×		
	810-427	Manual XY stage unit 2" x2"		●		×		
System options	11AAC316	AVPAK-20	×			●		Except the United States, available overseas (See Notes)
	12AAG201	PC set	△					Available only in Japan. △ : Requires EXPAK V.6.
Optional accessories	810-425	AF stage unit		×		●		
	810-016	Standard vise		○			Jaw opening: 51 mm	
	810-017	Special vise		○			Jaw opening: 100 mm	
	810-013	Sheet specimen table			△		Thickness: Max. 5 mm	△ : Systems A and B only.
	810-014	Thin specimen table (horizontal)			△		Diameter: 0.4-3 mm	△ : Systems A and B only.
	810-015	Thin specimen table (vertical)			○		Diameter: 0.4-4 mm	
	810-019	Specimen-tilting table			△		Jaw opening: 37 mm, Tilting angle: ±15°, Rotating angle: ±25°	△ : Systems A and B only.
	810-020	Adjustable specimen table			△		Thickness: Max. 30 mm	△ : Systems A and B only.
	810-018	Rotary table			○		Minimum graduation: 1°	
	810-085	Sheet specimen table			○		Thickness: Max. 3 mm, Width: Max. 56 mm	
	810-095	Rotary tilting specimen table			○		Height: From 20mm, to the height minus the sample table height (50mm) from the allowable height system Width and diameter: 15-55 mm	
	810-870*	Specimen heater HST-250	○		△			△ : Automatic reading with AVPAK-20 not possible.
	810-650-1	Resin-molded specimen table ø25.4			○		ø25.4±0.5 mm Specimen height: 9-39 mm	
	810-650-2	Resin-molded specimen table ø30			○		ø30±0.5 mm Specimen height: 9-39 mm	
	810-650-3	Resin-molded specimen table ø31.75			○		ø31.75±0.5 mm Specimen height: 9-39 mm	
	810-650-4	Resin-molded specimen table ø38.1			○		ø38.1±0.5 mm Specimen height: 9-39 mm	
	810-650-5	Resin-molded specimen table ø40			○		ø40±0.5 mm Specimen height: 9-39 mm	
	19BAA061	Knoop indenter (for standard test force)			○			Can be selected to replace the Vickers indenter provided as a standard accessory.
	19BAA062	Knoop indenter (for low test force)			○			
	375-056	Objective micrometer	×		○		Scale graduation: 1 mm, Minimum graduation: 0.01 mm	For magnification calibration
Printers	02AGD600	Model DPU-414 (with a connection cable)	○		×		Receipt printer	For 100V
	264-504	Model DP-1VR	○		×		Digimatic mini-processor	
	936937	Connection cord	○		×		For DP-1VR 1 m	
	02AZD810D	U-WAVE-R	○		×			
	02AZD880D	U-WAVE-T	○		×		Buzzer type	
	02AZD790D	Dedicated connection cable for U-WAVE-T	○		×			
	06ADV380D	USB-ITN-D	○		×		Flat 10-pin	PC must be provided separately.
	11AAC236	EXPAK V.6.	○		×		Data processing software	Requires Microsoft Excel 2010
Others	02ATE760	Table			○		1800(W)×900(D)×740(H)mm	For testing machine and PC
	998923	System rack (vertical)			○			Only a PC can be mounted.
	810-641	Vibration isolator			○			Only the testing machine can be mounted.
	810-644	Wing for vibration isolator			○		For 810-641	Recommended if the video camera unit is to be attached
11AAC146	Plate for preventing toppling							

○: Selectable ●: One of each type must be selected from the choice offered ×: Cannot be selected △: Contact Mitutoyo Sales Dept.

*: To denote your AC power cable add the following suffixes to the order No.: A for UL/CSA, D for CEE, DC for CCC, E for BS, K for KC, C and No suffix are required for PSE.
Note: With regarding to the AVPAK-20, not for use and/or export to the United States of America.

System configurations

Model name			HM-210A	HM-210B	HM-210C	HM-210D						
Main unit	HM-210 manual model main unit	810-400 *	○	-	-	-						
	HM-210 system model main unit	810-403 *	-	○	○	○						
Specification of basic conditions	Applicable standards	JIS B 7725, ISO 6507-2										
	Test force (Variable test force)	Hardness symbol	HV0.01	HV0.02	HV0.03	HV0.05	HV0.1	HV0.2	HV0.3	HV0.5	HV1	
		N	98.07x10 ⁻³	196.1x10 ⁻³	294.2x10 ⁻³	490.3x10 ⁻³	980.7x10 ⁻³	1.961	2.942	4.903	9.807	
	(gf)	(10)	(20)	(30)	(50)	(100)	(200)	(300)	(500)	(1000)		
	Indenter approach speed	Fixed at 60 μm/s										
	Test force loading time	1- 99s Can be set in 1s increments.										
Test force duration time	0-999s Can be set in 1s increments.											
Test force unloading time	1- 99s Can be set in 1s increments.											
Model name			HM-220A	HM-220B	HM-220C	HM-220D						
Main unit	HM-220 manual model main unit	810-405 *	○	-	-	-						
	HM-220 system model main unit	810-408 *	-	○	○	○						
Specification of basic conditions	Applicable standards	JIS B 7725, ISO 6507-2										
	Test force (Variable test force)	Hardness symbol	HV0.00005	HV0.0001	HV0.0002	HV0.0003	HV0.0005	HV0.001	HV0.002	HV0.003	HV0.005	HV0.01
		N	0.4903x10 ⁻³	0.9807x10 ⁻³	1.961x10 ⁻³	2.942x10 ⁻³	4.903x10 ⁻³	9.807x10 ⁻³	19.61x10 ⁻³	29.42x10 ⁻³	49.03x10 ⁻³	98.07x10 ⁻³
	(gf)	(0.05)	(0.1)	(0.2)	(0.3)	(0.5)	(1)	(2)	(3)	(5)	(10)	
	Hardness symbol	HV0.02	HV0.03	HV0.05	HV0.1	HV0.2	HV0.3	HV0.5	HV1	HV2		
	N	196.1x10 ⁻³	294.2x10 ⁻³	490.3x10 ⁻³	980.7x10 ⁻³	1.961	2.942	4.903	9.807	19.61		
(gf)	(20)	(30)	(50)	(100)	(200)	(300)	(500)	(1000)	(2000)			
Indenter approach speed	Variable between 2 and 60μm/s. Can be set in 1μm/s increments (only for 30 gf or smaller; Fixed at 60 μm/s for 31 gf or greater)											
Test force loading time	1- 99s Can be set in 1s increments.											
Test force duration time	0-999s Can be set in 1s increments.											
Test force unloading time	1- 99s Can be set in 1s increments.											
Mechanism	Loading device	Test force control	Electromagnetic (voice coil)									
		Test force switching	Can be selected from touch panel		Can be selected by AVPAK-20							
	Turret	Drive method	Motor drive									
		Operation method	Touch panel / Manual		AVPAK-20 / Manual	AVPAK-20 / Remote Control Box button / manual						
Number of turret ports	Indenter shaft unit: Up to two can be installed (including the standard Vickers indenter shaft unit already installed); Objective lens unit: Up to four can be installed (including the standard 50X objective lens already installed)											
Controller	Display content	Integrated touch panel (5.7-inch color LCD)	Data-processing software									
		Indentation value	D1 D2, max. 5 digits each									
		Minimum display unit	For objective lenses of 50X or higher: 0.01μm For lower than 50X: 0.1μm									
		Hardness value	Maximum of four digits, Minimum: 0.1 HV/HK, Fracture toughness value									
		Test condition	Indenter (HV/HK), test force, loading, duration, and unloading times									
		Compensation	Cylinder, sphere, measurement									
	Calculation functions	Pass/Fail determination	OK/±NG									
		Other	XY positional data, turret position display, statistical calculation									
		Language used	Japanese, English, German, French, Italian, Spanish									
		Pass/Fail determination function	Determines whether or not the measured hardness is acceptable (OK/±NG) based on the upper and lower limits that have been set.									
Function for guiding measurement condition setup	Enter the indenter, specimen thickness, and presumed hardness to calculate the maximum test force.											
Compensation function	Cylindrical compensation, spherical compensation, measurement compensation											
Statistical calculation function	Number of data units, maximum value, minimum value, average, range, upper limit, lower limit, number of passes, number of fails, Number of values over upper limit, Number of values below lower limit, standard deviation (n-1), standard deviation (n)											
External connection interface		For printer: Serial interface (compatible with the RS-232C standard); For Digimatic interface and data communication: USB 2.0										
Maximum specimen dimensions / Maximum load capacity	Maximum specimen dimensions	Maximum specimen depth: 160 mm, Maximum specimen height: 72mm(HM-210D+Motorized XY stage) to 133mm(HM-210A+Manual XY stage)										
	Maximum load capacity	3kg	7kg	3kg								
Main unit power supply		39VA: 100/100-125/200/220-240V AC										
Main unit	External dimensions (excluding protrusions and stage)	Approx. 315 (W) x 671 (D) 595 (H) mm		Approx. 315 (W) x 586 (D) 741 (H) mm								
	Main unit mass	Approx. 43 kg										

Specifications: Optical system

Item	HM-210 manual model main unit	HM-220 manual model main unit	HM-210 system model main unit	HM-220 system model main unit	
Optical system	Infinitely corrected optical system, 4-port objective lens switching method				
Tube lens magnification	1x				
Illumination	Light source	White LED			
	Aperture diaphragm	Variable			
Standard objective lens	Lens	MH Plan 50X			
	Working distance	2.5mm			
Real field of view and imaging range	Real field of view: ø0.14 mm		Imaging range: 0.118 (H) mm x 0.089 (V) mm		
Measuring microscope (Ocular)	Length-measuring microscope with integrated encoder and eyepiece (10X)		Factory-installed options		
Objective lens unit (including holder) (factory-installed options)	MH Plan 2x	MH Plan 5x	MH Plan 10x	MH Plan 20x	MH Plan 100x
Order No.	11AAC104	11AAC105	11AAC106	11AAC107	11AAC108
Working distance	6mm	27mm	11.8mm	5.2mm	1.5mm
Measurement range	ø3.5mm (reference)	ø1.4mm (reference)	ø0.7mm	ø0.35mm	ø0.07mm
Imaging range (Vision unit)	2.95(H)mm x 2.21(V)mm	1.18(H)mm x 0.89(V)mm	0.59(H)mm x 0.44(V)mm	0.30(H)mm x 0.22(V)mm	0.059(H)mm x 0.044(V)mm

Specifications: Manual stage unit

Systems A and B

Item	Specification	
Order No.	810-420	810-423
Type	Manual XY 25x25	Manual XY 50x50
XY range	25x25mm	50x50mm
Table size	100x100mm	130x130mm
Minimum display unit	0.001mm	
Dimensions	221(W)x221(D)x37(H)mm	305(W)x305(D)x49(H)mm
Mass	2.5kg	6.6kg

Specifications: Motorized stage unit

Systems C and D

Item	Specification	
Order No.	810-421*	810-422*
Type	Motorized XY 50x50	Motorized XY 100x100
Motorized XY stage		
XY range	50mmx50mm	100mmx100mm
Table size	130mmx130mm	165mmx165mm
Repeatability	2µm	
Min. step feed	1µm	
Max. drive speed	25mm/s	
Dimensions	219(W)x219(D)x55(H)mm	276(W)x276(D)x55(H)mm
Mass	3.7kg	5.2kg
Control unit		
Power consumption	57VA	
Dimensions	300(W)x290(D)x92(H)mm	
Mass	4.7kg	

*: To denote your AC power cable add the following suffixes to the order No.:
A for UL/CSA, D for CEE, DC for CCC, E for BS, K for KC, C and No suffix are required for PSE.

Standard accessories

Order No.	Item	Specification/Remarks	Quantity
19BAA058	Diamond indenter ^{*1}	Vickers for HM-210	1
19BAA059	Diamond indenter ^{*1}	Vickers for HM-220	
-	Hardness testing block ^{*2}	700HMV0.3 25 mm (diameter) x 6 mm (thickness)	1
-	Indenter shaft unit ^{*1}	With Vickers indenter	1
-	Objective lens unit 50X ^{*1}		1
19BAA133	Spacer	Material: Bakelite 11 (W) x 42 (D) x 13 (H) mm	1
11AAB405	Extension shaft	For elevation shaft: 38 mm With two set screws	1
11AAB406	Extension shaft	For elevation shaft: 76 mm With two set screws	1
02DEA471	Dust cover	For the hardness testing machine main unit	1
-	Plastic Phillips screwdriver	No.1300 Phillips 2x100	1
-	Precision flathead screwdriver	No.205 flathead 1.2	1
-	Hex-head screwdriver	1.5mm	1
-	Hex-head screwdriver	2.5mm	2
-	Hex wrench	2.5mm	1
-	Hex wrench	3.0mm	1
-	Holder	Hanger bolt for the main unit	4
-	Cap ^{*1}	Cap for the holder	4
-	Cable clamp	Gray	2
-	Cable clamp	Black	2
-	Spiral tube	Black, approx. 2 m	1
02ZAA000	Power supply code set - PSE	Order No. suffix: C and No suffix	1
02ZAA010	Power supply code set- UL/CSA	Order No. suffix: A	
02ZAA020	Power supply code set- CEE	Order No. suffix: D	
02ZAA030	Power supply code set- BS	Order No. suffix: E	
02ZAA040	Power supply code set- CCC	Order No. suffix: DC	
02ZAA050	Power supply code set- KC	Order No. suffix: K	
99MBG127A	User's manual for the manual model main unit	English	1
99MBG137A	User's manual for the system model main unit	English	
11PAA074	Accessory case		1
-	Certificate for the tester	In both Japanese and English	1
-	Certificate for the hardness test block	In both Japanese and English	1
-	Warranty	In both Japanese and English	1
-	USB camera (system main unit) ^{*1}	3 million pixels, 1/2-inch color Systems B, C, D	1

*1 Already installed in the main unit when it is delivered.

*2 The numeric values shown are nominal; actual values will be slightly above or below the nominal values.

Specifications: Video camera unit

System A

Item	Description
TFT screen magnification	Approx. 200X (approx. 260X) at 10X objective lens
	Approx. 1000X (approx. 1300X) at 50X objective lens
	Approx. 2000X (approx. 2600X) at 100X objective lens
CCD camera	Imaging method: EIA
	Imaging device: 1/3-inch interline CCD
	External dimensions: 31 (W) x72.5 (D) x29 (H) mm Mass; 85g
TFT monitor	Screen size: 210.4 mm diagonal (8.4-inch)
	Number of pixels: 640 (H) x480 (V)
	Rotation range: 350°
	Tilting range: -5-40°
	Power supply: 100-230V AC, 50/60Hz
	Power consumption: 12VA External dimensions: 228 (W) x61.5 (D) x195 (H) mm 232 (W) x 227 (D) x 426.5 (H) mm (when installed on the stand) Mass: 1.8 g (4.2 kg including the stand)

Specifications: Motorized auto focus stage unit

System D

Item	Specification
Travel (max.)	1.4mm
Table size	140mmx130mm
Repeatability	0.2µm
Min. step feed	0.1µm
Max. drive speed	1mm/s
Dimensions	245(W)x132(D)x40(H)mm
Mass	4.1kg

Micro Vickers hardness testing machines: HM-100 Series

The ideal series for Vickers hardness testing at the microscopic scale. Basic economy machines with the minimum requirement of functions for hardness testing. Two types are available: an analog model (HM-101) and a digital model (HM-102).

Measuring microscope

Analog type

Illumination unit

Design allows easy lamp replacement

Turret

Switches between indenters and objective lenses

Vise

Standard accessory
Clamping capacity: 51mm

Manual stage unit

Area: 100x100mm
XY range: 25x25mm
With analog micrometer head

Start switch

Test force switch knob

Indenter

Standard accessory: Vickers indenter

Objective lens

Standard accessories: 10X, 50X

Specimen table elevation wheel

Leveling screws

For leveling the unit

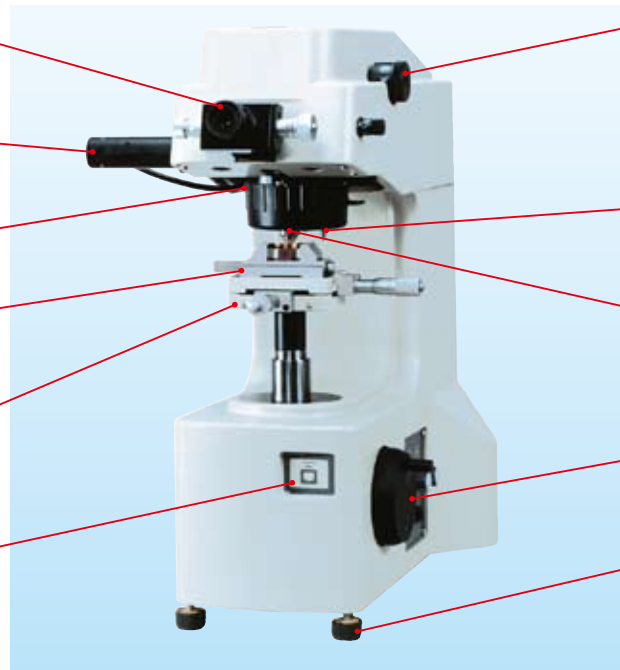

HM-101

Measuring microscope

Digital type

Control panel



HM-102

● Membrane switch type operation panel



● Electrical equipment on the rear panel

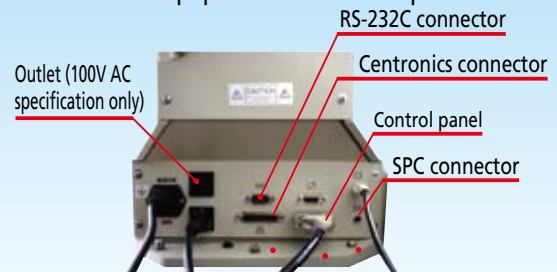

■ Specifications

Order No.	810-124*	810-125*
Model	HM-101	HM-102
Test force	mN: 98.07 245.2 490.3 980.7 1961 2942 4903 9807 gf: 10 25 50 100 200 300 500 1000	mN: 98.07 245.2 490.3 980.7 1961 2942 4903 9807 gf: 10 25 50 100 200 300 500 1000
Test force control	Auto (load, duration, unload)	
Test force duration time	5 to 30s (Arbitrary setting)	5 to 60s
Indenter approach speed	Approx. 60μm/s	
Specimen dimensions	Height: 95mm Depth: 150mm	
Optical path	Measurement path/exposure path (Optical path split method)	
Objective lens	10X (For observation), 50X (For measurement)	10X, 50X (Measurement available with both lenses)
Minimum display	0.2μm	0.1μm
Maximum measurement length	140μm	Objective lens 10X: 700μm Objective lens 50X: 140μm
Manual XY stage	With analog micrometer head, Minimum graduation 10μm	
Table size	100×100mm	
Stage XY range	25×25mm	
Measurement magnification calibrator	-	Installed
Data processing function	-	Indentation diagonal length Hardness value Pass/failure decision function
TV device Camera (1/3inch) Monitor (8inch monochrome)	-	Optional accessory
Turret switch	Manual	
External connection interface	-	For printer: Serial interface (compatible with the RS-232C standard), Digimatic interface, Centronics interface For motorized XY stage: I/O interfaces
Service power outlet	100/120V AC specifications only	
External dimensions	Main unit: Approx. 410(W)×600(D)×590(H)mm except operation panel	
Mass	Approx. 42kg	
Power supply	Approx. 60VA or less 120/220/240V AC according to the factory-shipped setting With TV monitor: Approx. 80VA or less	

Notes: (1) An optional Knoop indenter is required for Knoop hardness measurement
(2) HM-102/103 operation panel dimensions: 165(W)×260(D)×150(H)mm, 5kg
(3) HM-103 TV unit monitor dimensions: 232(W)×227(D)×426.5(H)mm, mass: 4.2kg

■ Standard accessories

Vickers indenter	19BAA114	1
Objective lenses	10×: 810-617 50×: 810-619	1
Fine adjustment table	810-011	1
Standard vise	810-016 Jaw opening: 51mm	1
Camera adapter	19BAA445	1
Hardness test block	700HV0.3 ø25mm	1
Power supply code set	One of any of the following: 02ZAA000 Order No. suffix: C and No suffix For PSE 02ZAA010 Order No. suffix: A For UL/CSA 02ZAA020 Order No. suffix: D For CEE 02ZAA030 Order No. suffix: E For BS 02ZAA040 Order No. suffix: DC For CCC 02ZAA050 Order No. suffix: K For KC	1
Tool kit	-	1
Accessory box	-	1
User's manual	-	1

Weights and loading shaft are included in the accessory box as standard accessories and need to be attached to the main unit during assembly

■ System configurations

Order no.	Model no.	Unit	TV unit (camera and monitor)
810-124*	HM-101	HM-101	-
810-125*	HM-102	HM-102	Optional accessory
810-959*	HM-103	HM-102	Standard accessory

*: To denote your AC power cable add the following suffixes to the order No.: A for UL/CSA, D for CEE, DC for CCC, E for BS, K for KC, C and No suffix are required for PSE.



Optional accessories



Objective lens

Lenses to meet your needs are available.

Objective lenses (Calibration by Mitutoyo required for replacements/changes)
Please inquire at your nearest Mitutoyo sales office

For HM 200 Series	For HM 100 Series
5X: 810-616	5X: 810-616
10X: 810-617	10X: 810-617
20X: 810-618	20X: 810-618
50X: 19BAA439	50X: 810-619
100X: 19BAA440	100X: 810-620

Accessories for collection and management of measurement data

External output application

264-504 Digimatic mini processor DP-1VR

Calculation of hardness values, statistical calculation, and control limit values can be performed
Note that a connection cable is not supplied with the DP-1VR and must be ordered separately. (See below.)
Connection cable (1m)
HM Series (**937387**) (except HM-101)
MVK-H Series (**936937**)



02AGD600A Printer DPU-414 With connection cable

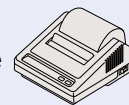

Part no. **11AAC236,237**
Data processing software
See page 39 for details



Diamond indenter

19BAA058 Vickers indenter
Applicable model **HM-210, HM-211, HM-101, 102, 103, 112, 113, 122, 123, MVK-H0, H1**

19BAA059 Vickers indenter
Applicable model **HM-220, HM-221, HM-114, 115, 124, 125, MVK-H2, H3**

19BAA061 Knoop indenter
Applicable model **HM-210, HM-211, HM-101, 102, 103, 112, 113, 122, 123, MVK-H0, H1**

19BAA062 Knoop indenter
Applicable model **HM-220, HM-221, HM-114, 115, 124, 125, MVK-H2, H3**

Hardness standard block

Hardness standard block	
19BAA010	40HV
19BAA001	100HV
19BAA002	200HV
19BAA003	300HV
19BAA004	400HV
19BAA005	500HV
19BAA006	600HV
19BAA007	700HV*
19BAA008	800HV
19BAA009	900HV

*Test conditions for hardness test blocks no. **19BAA001** to **009** are HV0.01, HV0.1 and HV1

*The test condition for the hardness test block supplied as a standard accessory with the testing machine is HV0.3

*Please select test blocks suitable for your specimens.

*Test condition values (annexed data) for this test block differ from those for the hardness test block supplied as a standard accessory (700HV)

Consumable parts, etc.

513667
Halogen illumination lamp 12V 50W
HM Series, AAV-500 Series
Please inquire at your nearest Mitutoyo sales office by quoting the model name and serial number



Various types of mounting table are available to suit the shape, dimensions or thickness of the objects to be tested.

Specimen fixture

810-013 Sheet specimen table

Prevents variations of hardness results due to flexure and wrinkling during measurement of sheets 0.5mm thick or less (e.g. Scalpel blades, etc.).

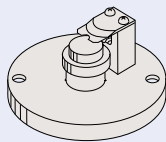

810-020 Adjustable specimen table (Specimen thickness of 30mm or less)

Allows proper alignment of the sample surface and the indenter axis when parallelism of the sample is poor. It cannot be used with automatic hardness testing systems.

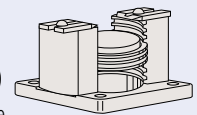

810-015 Thin specimen table (vertical type)

Clamps pin-shaped specimens of 0.4 to 3mm diameter or less in a chuck (e.g. Wire of steel or copper, etc.).

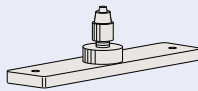

810-018 Rotary table (Minimum graduation 1°)

The specimen fixed on the table can be rotated for convenient measurement.

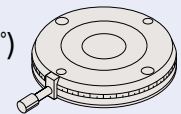

810-014 Thin specimen table (horizontal type)

Holds a thin specimen of 0.3 to 3mm for measuring on a side face (e.g. Wire, piano wire, etc.).

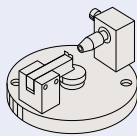

810-017 Special vise (Open width: 100mm)

Can clamp specimens of up to 100mm.

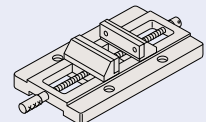

810-019 Tilting specimen table

Levels the specimen measurement face to prevent variations of indentation shape, with an opening width of 37mm, tilt angle of $\pm 15^\circ$, and rotation angle of $\pm 25^\circ$.

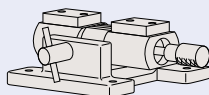

810-095 Rotary tilting specimen table

In cases where top and bottom surfaces of the specimen are not parallel, the tilting rotary specimen table's adjuster and standard accessory hand press can be used to make adjustments (adjustment range: $\pm 3^\circ$) so the top surface of the specimen is perpendicular to the indenter shaft of the hardness testing machine. When attached to the testing machine, the specimen surface can be rotated 360° (in 2° increments).

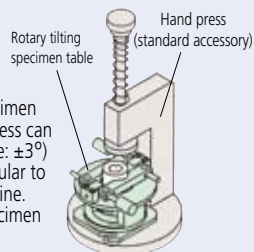

810-012 Manual XY stage (XY range: 50x50mm)

Allows specimen positioning up to 50mm in the X- and Y-directions.

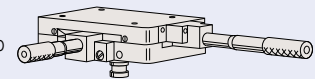

810-085 Sheet specimen table

Enables securing of very thin or narrow specimens like foil or fine wire.

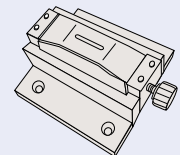

810-641 Vibration isolator

Only for mounting testing machines

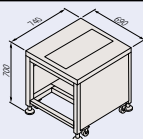

810-870 Specimen heater

Enables hardness testing at room temperature +10°C to 250°C (For HM-200).

Micro surface material-characteristics evaluation system

MZT-500 Series

A remarkably user-friendly micro surface material-characteristics evaluation system with an automatic multi-point measurement function

This system demonstrates outstanding performance in research and development and quality control of material characteristics in micro surface and submicroscopic areas, such as CVD, PVD, various vapor deposition membranes and generated ultra-thin membranes, as well as hardness, surface adherence properties, and wear resistance properties of a micro cross-section of carbon fibers, glass fibers, and whiskers, which cannot be measured with a conventional micro vickers hardness testing machine.



Indentation by triangular pyramid indenter

For evaluation of various materials

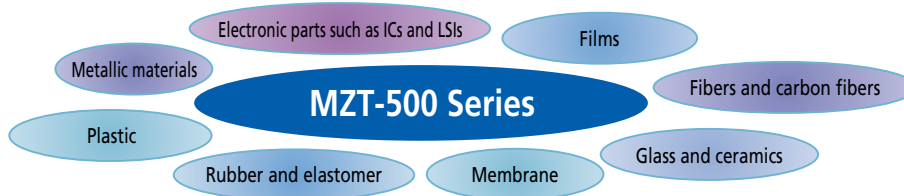

● Test data

You can obtain the indentation factor, which is related to the hardness value (partially) shown in "Instrumented indentation test for hardness" (ISO14577) and Young's modulus. Deformation characteristics in the load, duration, and unload phases are also obtainable for use in determining properties of the specimen material.

● Hardness tests such as Vickers and Knoop hardness tests are supported.

● The balance lever vibration isolation mechanism reduces the effect of external vibrations on measurements.

● Indentation depth can be measured up to a **maximum of 20μm** with a measurement resolution of **0.1nm**.

● Test force between **0.1mN** and **1000mN** can be applied electromagnetically for evaluation of material properties in submicroscopic areas.

● **Field-compatible form** with cover for protection against dust and wind.

● **High-temperature testing up to 250°C** High-temperature testing is possible by attaching the optional specimen heater (810-830 HST-250).



Automatic multi-point measurement device

Uses an XY automatic stage that can automatically perform tests on a pattern of measurement positions specified in advance. (MZT-500P only)



Interior of the automatic multi-point measurement device with the XY automatic stage

MZT-500

The MZT-500 Series fully covers micro areas with superior usability.

Test condition setting

Required test conditions can be set for each item. If any condition entered is incorrect, an error is displayed to ensure the correct setting. You can also call settings from the data bank.



Data analysis function 1

Test results are saved as text files retrievable with Microsoft Excel spreadsheet software. Macros are available for easy retrieval of test results with Excel.



Data analysis function 2

Statistical analysis and graph display of test results retrieved with Excel is easy. Functions such as graph overlay can also be used for visual presentation of the results.

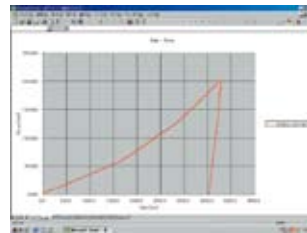

Measurement principle

Excel is either a registered trademark or trademark of Microsoft Corporation in the United States and/or other countries.

The test force loading mechanism electromagnetically applies a test force to the measurement sample via the non-friction balance lever and indenter. The point of contact of the indenter and specimen is regarded as the zero test force point, and a force is then applied up to the specified test force. During the process in which the indenter is pressed into the specimen, the indentation depth is measured with a displacement gage. By analyzing the 3 factors of test force, displacement (indentation depth) and time, various kinds of information can be obtained for each material.

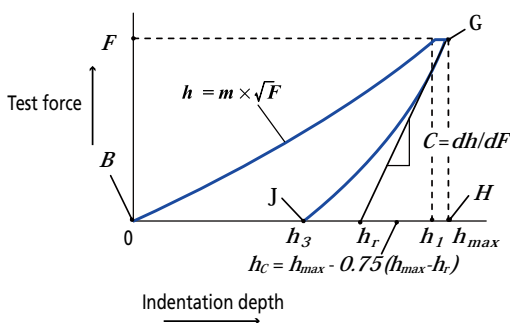
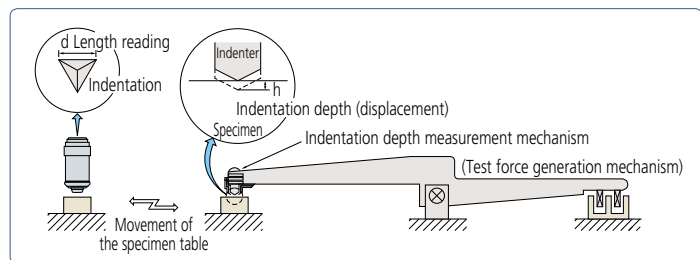

MZT analysis parameter		Definition	Description
Name	ISO notation		
Martens hardness	HM	$HM = \frac{F}{A_s \cdot h_{max}^2} \quad A_s = 26.43$	Hardness to elastic and plastic deformation
Martens hardness	HMs	$HMs = \frac{1}{A_s \cdot m^2}$	Average Martens hardness
Indentation hardness	H _{IT}	$H_{IT} = \frac{F}{A_P \cdot h_c^2} \quad A_P = 23.96$	Hardness of tested area
Indentation creep	C _{IT}	$C_{IT} = \frac{h_{max} - h_t}{h_t} \cdot 100$	Ratio of creep to total deformation
Indentation modulus	E _{IT}	$E_{IT} = \frac{1 - \nu_s^2}{2\sqrt{A_P} \cdot C} \cdot \frac{1 - \nu_i^2}{E_i}$	Equivalent Young's modulus
Indentation work ratio	η _{IT}	$\eta_{IT} = \frac{\text{Area (J-G-H)}}{\text{Area (B-G-H)}} \times 100$	Ratio between mechanical work and plastic deformation

ν_s: Poisson's ratio of the test piece ν_i: Poisson's ratio of indenter (for diamond 0.07)
E_i: Modulus of the indenter (for diamond 1.14×10⁶N/mm²)

Specifications

System

Order No.	Model	Description
810-813	MZT-500L	Digimatic specimen table (25×25)
810-814	MZT-500P	Automatic XY stage (50×50)

Item	Description
Test force loading device	Test force range: 0.1-1000mN Loading method: Balance lever Test force control: Electromagnetic Control resolution: 0.916μN Loading rate: 0.01 to 100mN/s
Indenter indentation depth measurement device	Measurement method: Electrostatic linear transducer Measurement range: 0-20μm Resolution: 0.1nm Linearity: Within ±0.7% of the full scale of 40μm
Indenter	Type: Bercovici triangular pyramid indenter Camera: 1/3 inch black and white (410,000 pixels)
Sample surface observation device	Objective lens (monitor magnification): 100X (approx. 2500X) 40X (approx. 1000X) 10X (approx. 250X) or 5X (approx. 125X)
Up/down device	Movable range: 0 to 70mm Driving method: Coarse adjustment unit: DC motor driven Jog unit: Stepping motor driven Movement resolution: 0.2μm or less (upon jog unit driving)
Vibration isolation function	For low frequencies: Oscillating vibration isolation mechanism For high frequencies: Rubber-type vibration isolation mechanism
Dimensions	Approx. 700(W)×870(D)×1100(H)mm
Mass	Approx. 180kg

Specimen table

Item	Description
Model	MZT-500L MZT-500P
Specimen table	Digimatic fine adjustment table Automatic XY stage
Specimen fine adjustment table	Travel range: 25(X)×25(Y)mm 50(X)×50(Y)mm
	Drive system: Manual Step motor drive
	Min. drive unit (display): 1μm 0.625μm
Specimen dimensions	Stage area: 100×100mm 130×130mm
	Max. specimen depth: 90mm (from center of indenter shaft) 500L:90mm, 500P:75mm (from top of specimen table)

Control unit

Item	Description
Dimensions	Approx. 250(W)×400(D)×450(H)mm
Mass	Approx. 15kg
Power supply	AC 100, 120, 220, 240V 50/60Hz
Power consumption	Approx. 100VA

Standard accessories

Basic system

Order No.	Item name	Description	Quantity
-	Basic system	Testing machine main unit, data storage/control device, sample surface observation device	1
810-634	Control device		1
810-099	Objective lens	M100X with fixing ring	1★
810-066	Objective lens	M40X with fixing ring	1★
19BAA300	Diamond indenter	Bercovici triangular pyramid indenter	1★
19BAA010	Hardness standard block	40HMV	1
-	Allen wrench	For indenter replacement	1
-	Hex-tip screwdriver	Across flats 1.5mm	2
-	Allen wrench	Across flats 2.5mm	1
-	Allen wrench	Across flats 4mm	1
810-016	Standard vise	Opening width 51mm	1
-	Standard vise fixing screw	M5 x 10mm Hex bolt	4
19BAA098	Level		1
-	Accessory box		1
19BAA314	Connection cable	Between the data storage/control device and testing machine main unit	1
19BAA315	Connection cable	Between the data analysis/control device and data storage/control device	1
-	PC table	800(W)×800(D)×700(H)	1
19BAA219	Halogen illumination lamp	6V20W	1
02ZAA000	Power cable	Cable length: 1.8m	1◇
-	Software	Main unit software and analysis software	1
-	Test certificate		
-	User's manual		

◇: Depends on the destination ★: Pre-installed at time of shipment

Essential accessory options

Order no.	Item	Description	Quantity
810-063	5X objective lens	5X finite system with fixing ring	1★
810-064	10X objective lens	10X finite system with fixing ring	

★: Pre-installed at time of shipment

Fine adjustment table (digital type) (MZT-500L)

Order no.	Item	Description	Quantity
19BAA523	Fine adjustment table (digital type)	•25(X)×25(Y)mm •With Digimatic micrometer head	1★
-	Connection cable	For connecting digital fine adjustment table and main unit	1★
-	Connection cable	For connecting main unit and control unit	1

★: Pre-installed at time of shipment

Automatic XY stage (MZT-500P)

Order no.	Item name	Specifications	Quantity
-	Automatic XY stage	50(X)×50(Y)mm	1★
-	Connection cable	For connecting automatic XY stage and main unit (special cable)	1★

★: Pre-installed at time of shipment

Operation unit (PC) (equivalent to the following)

PC	CPU: Core 2 Duo 2.8GHz or above; memory: 2GB or more HDD: 160GB or more OS: Windows / Vista SP2; Office 2007
Monitor	17-inch TFT

Testing functions (operation unit (PC) software functions)

Function	Specification
Test types	Test A: Indentation test (with preliminary test force) Test B: Indentation test (without preliminary test force) Test C: Test with indentation depth limit Test D: Continuous indentation test Test E: Repeated indentation test
Data analysis	Hardness: Martens hardness (HM) Martens hardness (HMS) Indentation hardness (HIT) Hardness value taken from indentation length reading
	Material properties: Indentation creep (CIT); indentation modulus (EIT); indentation work ratio (η IT); plastic deformation; creep; elastic deformation
Graphical display	Real-time display: Test force - Indentation depth graph Test sequence graph
	Analysis results display: Test force - Indentation depth graph with test results Integral range during indentation creep calculation Test force - Indentation depth curve fit parameters Unloading curve slope calculation results
Compensation	Temperature drift: Automatic compensation possible
	Indenter tip shape: User specification of compensation factor
	Machine casing distortion: User specification of compensation factor

Automated testing functions (MZT-500P only)

Function	Specification
Automated testing	Teaching: It is possible to arbitrarily specify a test position on the specimen surface image using the mouse. Test position coordinates: It is possible to specify a test position by entering coordinates. Predefined patterns: Line, zigzag, 3-point staggered, circle matrix, arc patterns Arbitrary patterns: Patterns can be created by entering coordinates. Pattern combinations: Multi-point testing with combinations of predefined and arbitrary patterns is possible.

Data analysis software (Excel data analysis macros)

Function	Specification
Graph creation	Indentation depth - Test force; Time - Test force; Time - Indentation depth; Indentation depth - Square root of test force; Test force - Hardness; Indentation depth - Hardness Test position - Hardness; 2D hardness distribution diagrams; 3D hardness distribution diagrams; Number of loads - Indentation depth ratio (Test E); Indentation depth - Test force/Indentation depth
Statistical analysis	Data count; maximum value; minimum value; mean value; range; standard deviation (n-1); coefficient of variation
Indenter shape compensation	User specification of compensation factor
Older data reading	Supports data from MZT-511, -512, -521 and -522

Optional accessories

Order No.	Item	Specification	Notices
19BAA300	Bercovici indenter	Diamond triangular pyramid indenter Face angle relative 65.3°	
19BAA301	Diamond indenter	Triangular pyramid indenter Face angle relative to axis 45°	
19BAA302	Diamond indenter	Triangular pyramid indenter Face angle relative to axis 60°	
19BAA303	Diamond indenter	Triangular pyramid indenter Face angle relative to axis 74°	
19BAA304	Diamond indenter	Triangular pyramid indenter Face angle relative to axis 80°	
19BAA305	Diamond indenter	Vickers indenter	
19BAA306	Diamond indenter	Knoop indenter	
19BAA307	Diamond indenter	Spherical indenter R0.25mm	
19BAA308	Diamond indenter	Spherical indenter R0.5mm	
19BAA309	Diamond indenter	Flat indenter ø0.02mm	
19BAA310	Diamond indenter	Flat indenter ø0.05mm	
19BAA311	Diamond indenter	Flat indenter ø0.1mm	
19BAA312	Diamond indenter	Flat indenter ø0.2mm	
19BAA313	Diamond indenter	Flat indenter ø0.5mm	
19BAA001	Hardness standard block	100HMV (Test force; 9.807N, 980.7mN, 98.07mN)	Note 1
19BAA002	Hardness standard block	200HMV (Test force; 9.807N, 980.7mN, 98.07mN)	Note 1
19BAA003	Hardness standard block	300HMV (Test force; 9.807N, 980.7mN, 98.07mN)	Note 1
19BAA004	Hardness standard block	400HMV (Test force; 9.807N, 980.7mN, 98.07mN)	Note 1
19BAA005	Hardness standard block	500HMV (Test force; 9.807N, 980.7mN, 98.07mN)	Note 1
19BAA006	Hardness standard block	600HMV (Test force; 9.807N, 980.7mN, 98.07mN)	Note 1
19BAA007	Hardness standard block	700HMV (Test force; 9.807N, 980.7mN, 98.07mN)	Note 1
19BAA008	Hardness standard block	800HMV (Test force; 9.807N, 980.7mN, 98.07mN)	Note 1
19BAA009	Hardness standard block	900HMV (Test force; 9.807N, 980.7mN, 98.07mN)	Note 1
19BAA010	Hardness standard block	40HMV (Test force; 9.807N, 980.7mN, 98.07mN)	Note 1
810-830	Specimen heater	HST-250 (max. 250°C)	Note 2
810-013	Sheet installation table	Thickness within 5mm	
810-014	Thin specimen table (horizontal)	For diameters of 0.4 to 3mm	
810-015	Thin specimen table (vertical)	For diameters of 0.4 to 4mm	
810-018	Rotary table	Min. graduation: 1°	
810-019	Tilting specimen table	Jaw width: 37mm; tilt angle: ±15°; rotation angle: ±25°	
810-020	Universal specimen table	For thicknesses up to 30mm	
810-085	Sheet specimen table	For thicknesses up to 3mm and widths up to 56mm	
810-095	Rotary tilting specimen table	For heights of 20mm or more and widths/diameters of 15 to 55mm	

Note 1: Hardness test blocks are Vickers hardness test blocks and should be used with this testing machine for comparative purposes

Note 2: Factory option



Vickers hardness testing machine

AVK-C0 HV-100 Series

You can choose from a wide variety of machines from the AVK-C0, an economical manually operated model, to high-performance models whose objective lenses can all be used for length measurement and that have an automatic indexing function for the objective lens and indenter.

**810-160
AVK-C0**
Economical manual type



Test force range: 9.807-490.3N

**810-163
HV-112**
High-spec digital model with auto turret and large black-and-white LCD touch screen control unit.



Test force range: 1.961-196.1N

**810-165
HV-114**
High-spec digital model with auto turret and large black-and-white LCD touch screen control unit.



Test force range: 9.807-490.3N

**810-981
HV-113**
High-spec digital model with arbitrary test force setting, auto turret, large black-and-white LCD touch screen control unit, TV camera and monitor



Note that the indentation image is a composite image

Test force range: 1.961-196.1N

**810-985
HV-115**
High-spec digital model with arbitrary test force setting, auto turret, large black-and-white LCD touch screen control unit, TV camera and monitor



Note that the indentation image is a composite image

Test force range: 9.807-490.3N

Vickers hardness testing machine

HV-100 Series

A high-spec Vickers hardness testing machine series. Two types are available—a low test force type (HV-112), which also supports the test force range of microhardness testing machines, and a general purpose type (HV-114) supporting a basic test force range.

- Power turret allows one-touch switching between objective lenses and indenters.
- All basic operations can be performed using the touch screen operation panel.



- A measurement calibrator allows all objective lenses to be used for length measurement.
- Includes as standard statistical analysis functions required for hardness testing.
- Includes as standard a pass/fail determination function useful for incoming inspections and other areas of quality control.
- Supports fracture toughness testing of ceramics using the IF method included in JIS standards.

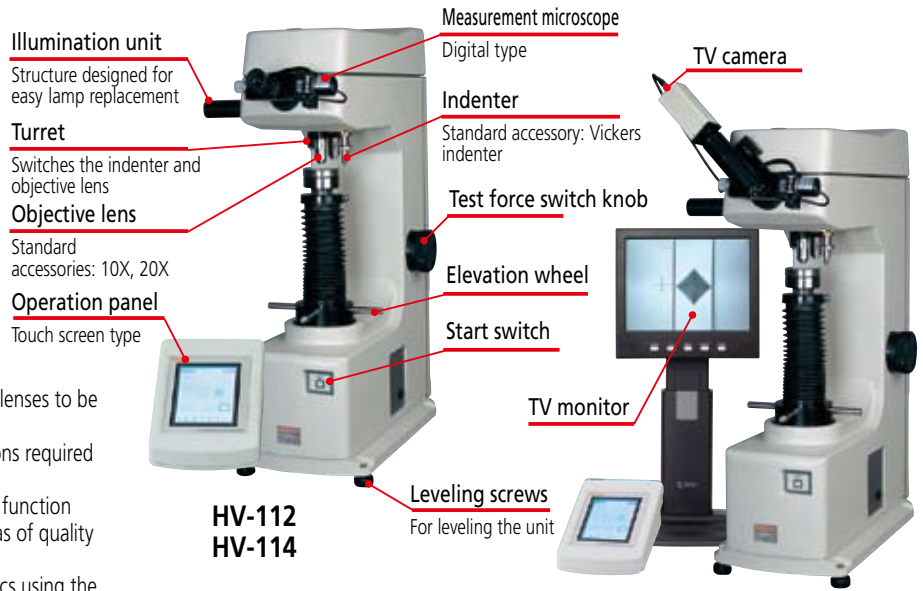

HV-112
HV-114

HV-113
HV-115

* Indentation image is a composite image

Specifications

Order No.		810-163*				810-165*			
Model		HV-112				HV-114			
Test force	N	1.961	2.942	4.903	9.807	9.807	19.61	29.42	49.03
	kgf	24.51	49.03	98.07	196.1	98.07	196.1	294.2	490.3
		0.2	0.3	0.5	1	1	2	3	5
		2.5	5	10	20	10	20	30	50
Test force control		Automatic							
Test force duration time		5 to 99s							
Indenter approach speed		20/50/100/150µm/s							
Specimen dimensions		Maximum height of 210mm or less (when the flat anvil is used) Maximum depth 170mm							
Optical path		Measurement path / exposure path Optical path split method							
Objective lens		10x, 20x (Measurement available with both lenses)							
Minimum display		0.1µm							
Maximum measurement length		Objective lens 10X: 700µm, 50X: 140µm							
Measurement magnification calibrator		Included							
Data processing function		Vickers/Knoop*/Brinell*1 hardness calculation; indentation diagonal length display; ceramics fracture toughness calculation based on IF method (JIS R 1607) Conversion (HRA/B/C/D/F/G, 15/30/45T, 15/30/45N, / HV / HK / HS / HB / TENS) Statistical calculation (maximum value, minimum value, mean, range, standard deviation, pass/fail determination, etc.) Language support (Japanese, English, German, French, Italian, Spanish)							
TV unit (camera and monitor)		Optional accessory (HV-113 and HV-115: standard accessory)							
Turret switch		Motor-driven							
External connection interface		For printer: Serial interface(compatible with the RS-232C standard), Digimatic interface, Centronics interface For motorized XY stage: I/O interfaces							
External dimensions		Main unit: Approx. 245(W)×515(D)×770(H)mm except operation panel							
Mass		Body: Approx. 57kg Operation panel: Approx. 5kg							
Power supply		Approx. 70VA or less AC120V, AC220V, AC240V according to the factory-shipped setting With TV monitor : Approx. 90VA or less							

*1 Optional Knoop and Brinell indenters are required respectively for Knoop hardness testing and Brinell hardness testing

Notes: (1) HV-113/115 TV unit monitor dimensions: 232x227x426mm (WxDxH); mass: 4.2kg

(Both for HV-100 Series and AVK-C0)

(2) Operation panel dimensions: 165(W)×260(D)×105(H)mm

Standard accessories (For both HV-100 Series and AVK-C0)

Diamond indenter (for Vickers)	19BAA060	1
Flat anvil	810-039 Outside ø64mm	1
V anvil (large)	810-040 ø40mm Outside ø40mm, groove width 30mm	1
V anvil (small)	810-041 ø40mm Outside ø40mm, groove width 6mm	1
Hardness test block	19BAA016 700HV10 ø65mm	1
Power supply code set	One of any of the following: 02ZAA000 Order No. suffix: C and No suffix For PSE 02ZAA010 Order No. suffix: A For UL/CSA 02ZAA020 Order No. suffix: D For CEE 02ZAA030 Order No. suffix: E For BS 02ZAA040 Order No. suffix: DC For CCC 02ZAA050 Order No. suffix: K For KC	1
Tool kit	—	1
Accessory box	—	1
User's manual	—	1

Weights and loading shaft are included in the accessory box as standard accessories and need to be attached to the main unit during assembly

System configurations

Order no.	Model no.	Unit	TV unit (camera and monitor)
810-163*	HV-112	HV-112	Optional accessory
810-981*	HV-113	HV-112	Standard accessory
810-165*	HV-114	HV-114	Optional accessory
810-985*	HV-115	HV-114	Standard accessory

* To denote your AC power cable add the following suffixes to the order No.: A for UL/CSA, D for CEE, DC for CCC, E for BS, K for KC, C and No suffix are required for PSE.



Vickers hardness testing machine AVK-C0

AVK-C0 is a basic economy Vickers hardness testing machine

Vickers hardness testing machine AVK-C0

A basic Vickers hardness testing machine that is economical and simple.



Specifications

Order No.	810-160*					
Model	AVK-C0					
Test force	N	9.807	49.03	98.07	196.1	294.2 490.3
	kgf	1	5	10	20	30 50
Test force control	Automatic method (load, duration, unload)					
Test force duration time	5, 10, 15, 20, 30S switching method					
Test force method	Final test force deceleration method					
Specimen maximum dimensions	Height 205mm, depth 165mm (When the flat anvil is used)					
Optical path switching	None					
Objective lens	10X (For measurement)					
Measurement resolution	1μm					
Maximum measurement length	Objective lens10X : 700μm					
Turret switching	Manual					
External connection interface	None					
External dimensions	Approx. 200(W)x600(D)x705(H)mm					
Mass	50kg					
Power supply	AC100V 50/60Hz (switchable between 120, 220, and 240V AC) , 60VA or less					

Note1: An optional Knoop indenter is required for Knoop hardness testing

Note2: A hardness calculation table is supplied with AVK-C0 as a standard accessory. All other standard accessories, except for objective lens configurations, are the same as for the HV-100 Series. Please refer to the HV-100 Series page.

Note3: With AVK-C0, hardness values are obtained from the hardness calculation table based on indentation size measurements and the test force

*: To denote your AC power cable add the following suffixes to the order No.:

A for UL/CSA, D for CEE, DC for CCC, E for BS, K for KC, C and No suffix are required for PSE.

System set-ups

● VLPK2000

Used in combination with a hardness testing machine, VLPK2000 automatically reads the diagonal length of an indentation and converts the result into a hardness value. This is useful for reducing measurement error due to operator variations. VLPK2000 also dramatically improves the work efficiency of hardness testing with an automatic reading speed of 0.3 seconds allowing fast hardness measurements.



Order No.	810-312-11	
Model	VLPK2000	
Measured hardnesses (automatic)	HV and HK	
Reading method	Quadratic regression; reading speed: 0.3 sec.	
Manual measuring method	Video line measurement; HV and HK	
Conversion	Hard steel	HV, HK, HBS, HS, TENS, HRA, HRC, HRD, HR15N, HR30N, HR45N
	Soft metal	HV, HK, HBS, TENS, HRA, HRF, HRB, HRG, HR15T, HR30T, HR45T
Pass/fail determination	Pass/fail can be calculated at measurement	
Image saving	Available on each operation screen	
Measurement data saving	Saved in text format; can be processed using data processing macros	
Control	Power turret; test force duration time; indentation	

Please refer to the HV-100 Series for testing machine specifications.

Needs to be used in combination (purchased together) with Vickers hardness testing machine HV-112 or HV-114

● AT-400

Besides an automatic stage control function useful for multi-point measurements, AT-400 also has an automatic indentation reading function, thereby simultaneously improving work efficiency and reducing fluctuations in measurement error due to operator variations.



Order No.	810-314-11	
Model	AT-400	
Measured hardnesses (automatic)	HV and HK	
Automatic reading function	Refer to VLPK2000 specifications	
Automatic XY stage	Stage area: 130x130mm; travel range: 50x50mm; min. pitch: 1μm	
Control software functions	Measurement patterns: line, zigzag, 3-point staggered, matrix, circle, arc, random, teaching; measurement pattern combination; hardness calculation; hardness conversion; pass/fail determination	
Measurement data saving	Saved in text format; can be processed using data processing macros	
Control	Power turret; test force duration time; indentation	

Please refer to the HV-100 Series for testing machine specifications

Needs to be used in combination (purchased together) with Vickers hardness testing machine HV-112 or HV-114

● AAV-500

Fully automates all processes required for hardness testing such as loading, focusing, indentation reading, and measuring point positioning. Reading time is an amazing 0.3 seconds.



Order No.	810-727	810-728
Model	AAV-503	AAV-504
Objective lenses	10X, 20X	
Test force	Same as for HV-112 (1.961 to 196.1N)	Same as for HV-114 (9.807 to 490.3N)
Manual measuring method	Video line measurement; HV and HK	
Automatic reading function	Refer to VLPK2000 specifications	
Automatic stage control functions	Refer to AT-400 specifications	
Autofocusing	Focus time: Varies according to the specimen surface conditions	
Analysis software functions	Test conditions display; measurement data display; statistical analysis; graphical representation	
Installation floor area/mass	665(W)x516(D)x1000(H)mm / 91kg	

Please refer to the HV-100 Series for testing machine specifications

Vickers hardness testing machine is included as a standard accessory

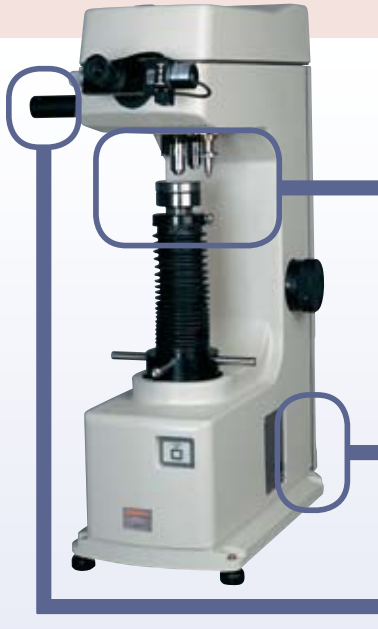

Optional accessories

Specimen fixtures and tables

810-012
Manual XY stage 125 x 125mm
(50mm stroke)

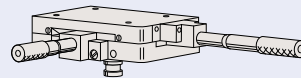

810-037
Round table
Outside ø180mm



810-016
Standard vise
(Opening width 45mm)

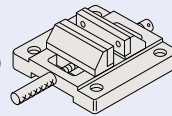

810-038
Round table
Outside ø250mm



810-017
Special vise
(Opening 100mm)

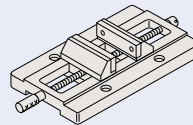

Item	Order No.
Hardness standard block 200HV *2	19BAA011
Hardness standard block 300HV *2	19BAA012
Hardness standard block 400HV *2	19BAA013
Hardness standard block 500HV *2	19BAA014
Hardness standard block 600HV *2	19BAA015
Hardness standard block 800HV *3	19BAA017
Hardness standard block 900HV *3	19BAA018
Hardness standard block for Brinell 200HBw	19BAA027
Diamond indenter (for Knoop)	19BAA063
Cemented carbide spherical indenter for Brinell 1.0mm	19BAA277
Cemented carbide spherical indenter for Brinell 2.5mm	19BAA279
Cemented carbide spherical indenter for Brinell 5.0mm	19BAA280
Cemented carbide spherical indenter for Brinell 1.0mm, one unit	19BAA281
Cemented carbide spherical indenter for Brinell 2.5mm, one unit	19BAA283
Cemented carbide spherical indenter for Brinell 5.0mm, one unit	19BAA162
Test force weight for Brinell 1.25kgf	19BAA087 *1
Test force weight for Brinell 2.5kgf	19BAA088 *1
Test force weight for Brinell 2.8125kgf	19BAA089 *1
Test force weight for Brinell 4.0kgf	19BAA090 *1
Test force weight for Brinell 5.0kgf	19BAA091 *1
Test force weight for Brinell 5.625kgf	19BAA092 *1
Test force weight for Brinell 10.0kgf	19BAA093 *1
Test force weight for Brinell 12.5kgf	19BAA094 *1

*1: For AVK-CO only.

*2: Test conditions for hardness test blocks are HV1 and HV10

*3: Test conditions for hardness test blocks are HV1 and HV30

External output devices

264-504
Digimatic mini processor
DP-1VR

No connection cable is supplied with the DP-1VR. (Should be ordered separately)
Connection cable (1m)
HM Series **(937387)**



810-622
Printer
DPU-414
Connection cable
(12AAA804)

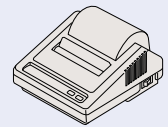

11AAC237
Data processing software
See page 39 for details

Consumable parts

19BAA219
Halogen illumination lamp 6V 20W
AVK-C Series

513667
Halogen illumination lamp 12V 50W
HV-100 Series, AAV-500 Series
For replacement, please inquire at your nearest Mitutoyo sales office by quoting the model name and serial number

Other optional accessories

810-640
Vibration isolator
Only for mounting testing machines

Console table for testing machine
810-048

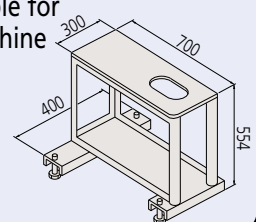

Rockwell hardness testing machine

HR series

**963-210
HR-110MR**



**963-220
HR-210MR**



- Basic models with analog displays.
No zero-setting required due to inclusion of an automatic preset gauge.

**963-231
HR-320MS**



- Economy testing machine able to perform both Rockwell and Rockwell Superficial hardness testing.

With additional optional accessories, all HR Series models can be used to perform Brinell hardness testing.

Note 1. Requires Brinell ball indenter and measuring microscope (and additional weights).

**963-240
HR-430MR**



**963-241
HR-430MS**



- Economy testing machines able to perform both Rockwell and Rockwell Superficial hardness testing. (HR-430MS)
- Economy models with automatic wheel brakes.

**810-202 HR-521
810-203 HR-522
810-204 HR-523**



- These models use a dolphin-nose indenter to maximize space around the test zone so more specimens of various shapes can be tested without having to section them.



Rockwell hardness testing machine

HR-100/200/300/400 Series

Analog Rockwell hardness testing machines HR-110MR/210MR



**HR-110MR
963-210**
Rockwell hardness testing machine
An environmentally friendly energy-saving model. The basic operation is all manual, including weight changing (total test force selection).

**HR-210MR
963-220**
Rockwell hardness testing machine
Manual weight changing (with total test force selected) and handling of preliminary test force. Motor drive controls loading sequence.

Digital Rockwell hardness testing machines HR-320MS/430MR/430MS



**HR-320MS
963-231**
**Dual type (Rockwell/
Rockwell superficial)
hardness testing machine**
Manually handles test force and preliminary test force selection. Motor drive controls loading sequence.

**HR-430MR
963-240**
Rockwell hardness testing machine
Economy type, but supports dial switching power steering and support of all test standards and equipped with automatic brake handle auto start feature. Motor drive controls loading sequence.

**HR-430MS
963-241**
**Dual type (Rockwell/
Rockwell superficial
combined use) hardness testing machine**
Economy type, but supports dial switching power steering and support of all test standards and equipped with automatic brake handle auto start feature. Motor drive controls loading sequence.

Rockwell hardness testing machine
HR Series

Features

- The newly designed frame provides maximum clearance for positioning the workpiece. A flat table is all that is needed for mounting these testing machines.
- Simple to operate
With analogue type (HR-110MR, HR-210MR), the gauge presetting operation is rendered unnecessary by the adoption of an automatic presetting dial gauge.
- HR-110MR does not require a power source, and is considered to be environmental friendly.
- Digital types (HR-430MR/430MS), use an automatic steering wheel brake and automatic loading sequencing, making for easy operation.
- Digital types (HR-320MS/430MR/430MS) have digimatic output and our Digimatic Mini-Processor (DP-1VR) for hardcopy output, as well as input tools (USB-ITN-E) to connect to a PC for data transfer.



- Brinell hardness tests can be performed by using the following optional accessories: a Brinell indenter, a weight set and a measurement microscope.

Specifications

Order No.	963-210	963-220*	963-231*	963-240*	963-241*
Model	HR-110MR	HR-210MR	HR-320MS	HR-430MR	HR-430MS
Preliminary test force (N)	98.07		29.42 98.07	98.07	29.42 98.07
Test force (N)					
Superficial	—		147.1 294.2 441.3	—	147.1 294.2 441.3
Rockwell			588.4 980.7 1471		
Supported hardnesses	—	—	Rockwell Superficial hardness	—	Rockwell Superficial hardness
Standard	JIS B 7726 ISO6508-2 (ASTM E18)				
Hardness display	Analog		Digital		
Resolution	0.5HR graduation		0.1HR indication		
Preliminary test force (handling support)	Automatic pre-setting dial gauge		Loading navigator indication	Automatic steering wheel brake	
Preliminary test force setting	—	—	Dial switching	—	Dial switching
Total test force setting	Weight change		Dial switching		
Total test force control	Manual	Motor drive Button start		Motor drive Automatic start	
Test force duration	Manual	Fixed 3-5.5s or manual		3-60s setting or manual operation	
Maximum specimen height	180mm (100mm if cover is attached)				
Maximum specimen depth	165mm (from indenter axis to the frame)				
Function	—	—	pass or failure decision function		
	—	—	Offset revision function		
	—	—	Hardness conversion function		
External communication interface	—	—	For printer: Serial interface (compatible with the RS-232C standard), Digimatic interface		
Power supply	No power required	100-240V AC 1.2A (AC adapter DC12V 3.5A)			
External dimensions	Approx. 296(W) x 512(D) x 780(H)mm	Approx. 235(W) x 512(D) x 780(H)mm	Approx. 235(W) x 516(D) x 780(H)mm		
Mass	Approx. 49kg	Approx. 47kg	Approx. 47kg	Approx. 50kg	

*: To denote your AC power cable add the following suffixes to the order No.:
 -10A for UL/CSA, D for CEE, DC for CCC, E for BS, K for KC, C and No suffix are required for PSE.

Standard accessories Brinell hardness tests can be performed by using the following optional accessories: a Brinell indenter, a weight set and a measurement microscope.

Order No.	Item	Description
—*1	Diamond indenter	For R (for HR-xxxMR)
—*1	Diamond indenter	For R/S (for HR-xxxMS)
—	Steel ball indenter	ø1/16" (ø1.5875mm)
—	Steel ball (spare)	ø1/16" (ø1.5875mm)
—	Flat anvil	ø64mm
—	V-anvil (large)	ø40mm, 120° V-groove 30mm wide
—	Hardness test block	60-65HRC
—	Hardness test block	30-35HRC
—	Hardness test block	90-95HRB
—	Hardness test block	65HR30N (only HR-xM Sattachment)
—	Hardness test block	70HR30T (only HR-xMS attachment)

Order No.	Item	Description
—	Hardness test block	70HR30T (only HR-xMS attachment)
357651	AC adapter	AC100-240V, 1.2A DC12V, 3.5A
Specify one of the following (must match machine Order No. suffix):		
02ZAA000	Order No. suffix: C and No suffix For PSE	
02ZAA010	Order No. suffix: A For UL/CSA	
02ZAA020	Order No. suffix: D For CEE	
02ZAA030	Order No. suffix: E For BS	
02ZAA040	Order No. suffix: DC For CCC	
02ZAA050	Order No. suffix: K For KC	
	User's manual	Depends on destination country
56AAK312	Vinyl cover	
—	Accessory box	
—	Level	

*1: Available for specific model.

Brinell hardness testing, the following optional accessories are required: an indenter, a weight set and a measurement microscope.

Hardness testing machine	Weight set		Indenters for Brinell test			
	Order No.	Item	19BAA277 ø1mm	19BAA279 ø2.5mm	19BAA280 ø5mm	19BAA284 ø10mm
HR-110MR HR-210MR	56AAK286	Brinell weight set for HR110MR, 210MR 62.5 125 187.5	—	HBW2.5/62.5 HBW2.5/187.5	HBW5/62.5 HBW5/125	(HBW10/100*)
HR-320MS	56AAK287	Brinell weight set for HR-320MS 31.25 62.5 125 187.5	(HBW1/10*) (HBW1/30*)	HBW2.5/31.25 HBW2.5/62.5 HBW2.5/187.5	HBW5/62.5 HBW5/125	(HBW10/100*)
HR-430MR	56AAK288	Brinell weight set for HR-430MR) 62.5 125 187.5	—	HBW2.5/62.5 HBW2.5/187.5	HBW5/62.5 HBW5/125	(HBW10/100*)
HR-430MS	56AAK289	Brinell weight set for HR-430MS 31.25 62.5 125 187.5	(HBW1/10*) (HBW1/30*)	HBW2.5/31.25 HBW2.5/62.5 HBW2.5/187.5	HBW5/62.5 HBW5/125	(HBW10/100*)

Measurement microscope for Brinell hardness test

Order No.	Item
19BAA318	Measurement microscope (40X model)
19BAA319	Measurement microscope (100X model)

Spare cemented carbide ball

Order No.	19BAA281	19BAA283	19BAA162	19BAA163
Item	1mm	2.5mm	5mm	10mm
Size (Quantity)	ø1mm (1 pc.)	ø2.5mm (1 pc.)	ø5mm (1 pc.)	ø10mm (1 pc.)

*The built-in weights are used for this range. Only an indenter need be selected.

Rockwell hardness testing machine

HR-500 Series **wiZhard**

The HR-500 Series provides the latest testing machines that can perform 3 types of hardness testing: Rockwell, Rockwell Superficial, and the loading sequence for Brinell hardness tests by the adoption of electronic control.



810-202, -203
HR-521, 522



810-204
HR-523



Hardness testing of internal surfaces, which previously was impossible without sectioning, is now possible. (All models.)
The minimum diameter that can be tested is 34mm as standard. Measurement can be performed down to an inside diameter of 22mm by using the diamond indenter (**19BAA292**-optional).



The operation panel can be installed on top of the machine, which is very helpful when installation space is limited. (All models.)
The operation box installation plate (**19BAA295**-optional) is required for mounting.



Touch screen control panel

Advanced control panel able to perform functions such as statistical analysis and graphical display of test results in addition to basic functions.

Test force auto switch function

The type of the indenter is set in advance. The desired hardness scale can be selected on the operation panel.
The test force can be automatically switched to the level corresponding to the selected hardness scale.

Graphic display of \bar{X} -R control chart and statistical calculation results

Statistical calculation values such as the maximum, minimum, and mean, \bar{X} -R control charts, and histograms, which are required for hardness evaluation, can be displayed.

Equipped with the continuous measurement function

An electromagnetic brake means that handle operations are not required for measurement from the 2nd point. All operations can be completed by pressing buttons, which allows continuous, speedy measurement.

Various shapes of specimen can be measured. (Nose-type indenter has been adopted)

The nose-type indenter allows internal measurement of pipe samples as well as the top surface of a flat sample.

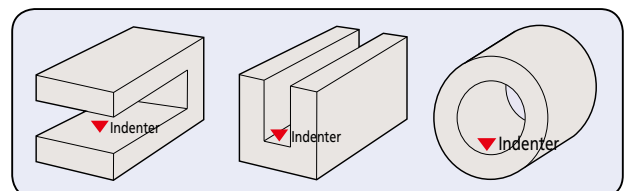

Control panel and functions

HR-521/522/5233 models employ a touch screen control panel with switchable display, enabling both a diverse range of functions and excellent operability.

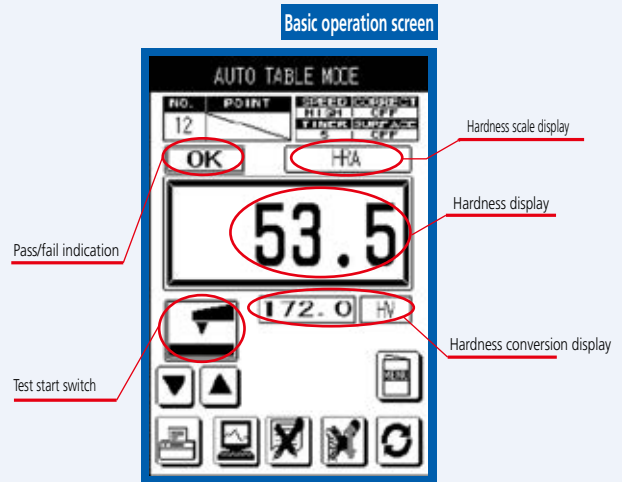

Direct hardness scale selection

The hardness scale, determined according to the test force and indenter combination, can be directly selected on the touch screen. Preliminary test force and test force are set automatically to match the chosen scale, offering great convenience.

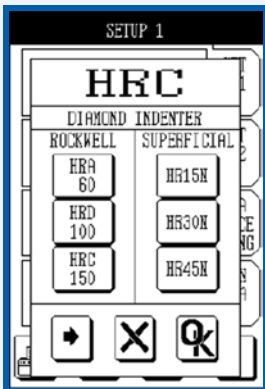

Curved surface compensation and measurement

The curve compensation function supporting specimens with curved surfaces such as round bars and spheres allows hardness testing of specimens of a wide range of shapes, not only flat specimens.

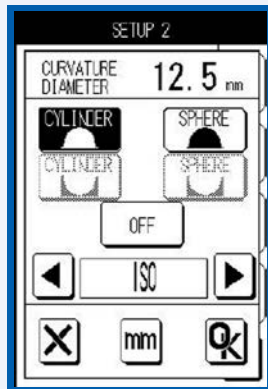

Statistical analysis

Quality control processes involving hardness testing of industrial materials employ judgments based on test results for multiple points. This function performing calculation of statistics such as maximum, minimum and mean values and standard deviations is useful for analysis of multi-point test results.

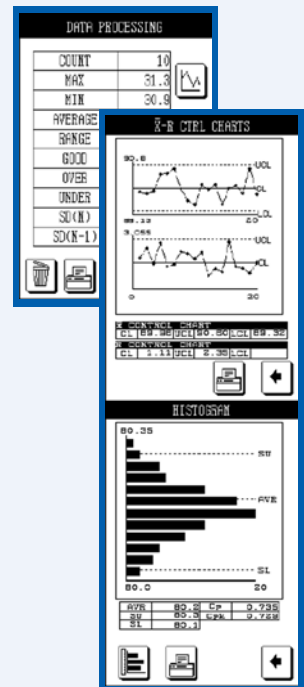
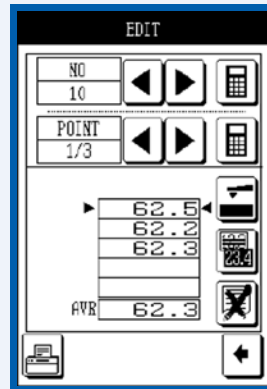



Specifications

Order No. Model	810-202* HR-521	810-203* HR-522	810-204* HR-523
Preliminary test force (N)	29.42 98.07		
Total test force (N) Superficial	147.1 294.2 441.3		
Rockwell	588.4 980.7 1471		
Brinell	1839	61.29 306.5	98.07 612.9
Test force control	Auto (load, duration, unload)		
Table up/down mechanism	Manual (Preliminary test force is auto braked)		Motor driven (manual operation is also available)
Operation unit	Membrane switch operation panel		
Test force switching	Switch operation		
Test force duration time	0 to 120s (Can be set to any value in units of 1s.)		
Specimen maximum dimensions	Height: 250mm (Long type: 395mm) Depth: 150mm		
Allowable inner diameter of pipe specimen	Minimum hole diameter: 35mm (When the special specification indenter is used: 22mm)		
Display	Hardness value, test condition, OK/NG judgment result, statistical calculation result, X-R control chart, hardness conversion value		
Function	Rockwell hardness test, Rockwell Superficial hardness test, Brinell hardness test (measurement microscope-optional and dedicated indenter are required)		
	Conversion function [HV, HK, HR (Rockwell hardness A, B, C, D, F, G / Rockwell Superficial 15T,30T, 45T, 15N, 30N, 45N) Tensile strength]		
	Pass or failure decision function		
	Continuous measurement function (for specimens of the same thickness)		
	Cylindrical correction, spherical correction, offset correction, multi-point correction functions		
	Statistical calculation function (Maximum value, minimum value, mean value, standard deviation, upper and lower limit values, OK count, range, NG count)		
Language support	6 languages are supported: Japanese, English, German, French, Italian, and Spanish.		
	Graph generation function (X-R control charts)		
External connection interface	For printer: Serial interface (compatible with the RS-232C standard), Digimatic interface, Centronics interface		
Power supply	100V AC, approx. 40VA or less, (120/220/240V AC set on shipment from factory.)		
External dimensions Mass	Body: Approx. 250(W) x 670(D) x 605(H)mm, (long types :750(H)mm), Approx. 65kg ((Long types: Approx. 75kg) Operation panel : approx. 165 (W) x 260 (D) x 105 (H)mm approx. 0.75kg		

Order No. and Models for long types: **810-205***: HR-521L **810-206***: HR-522L **810-207***: HR-523L

*: To denote your AC power cable add the following suffixes to the order No.:

A for UL/CSA, D for CEE, DC for CCC, E for BS, K for KC, C and No suffix are required for PSE.

Standard accessories

Order No.	Item	Specification	Order No.	Item	Specification	Order No.	Item	Specification
	Connection cable	For connection between the hardness testing machine main unit and display	19BAA114	Power cord	For 100V AC	—	Hardness test block	70 to 79HR30T
19BAA073	Diamond indenter	For Rockwell superficial		Vinyl cover			Fuse	
19BAA074	Steel ball indenter	1/16"	—	Hardness test block	30 to 35HRC		Accessory box	
19BAA082	Spare steel ball	1/16" 10 balls	—	Hardness test block	60 to 65HRC		Operating manual	
810-039	Flat anvil	ø64mm	—	Hardness test block	90 to 95HRB		Warranty card	
810-040	V anvil	ø64mm Groove width : 30mm	—	Hardness test block	64 to 69HR30N			

Additional information

The relation between the test force and indenter for Brinell hardness test is as follows.

For the Brinell hardness test, the following indenter (optional accessory) and measurement microscope are required.

Test force	Brinell									
	61.29	98.07	153.2	245.2	294.2	306.5	612.9	980.7	1226	1839
19BAA277 ø1 Indenter for Brinell test		HBW1/10			HBW1/30					
19BAA279 ø2.5 Indenter for Brinell test	HBW2.5/6.25		HBW2.5/15.625			HBW2.5/31.25	HBW2.5/62.5			HBW2.5/187.5
19BAA280 ø5 Indenter for Brinell test				HBW5/25			HBW5/62.5		HBW5/125	
19BAA284 ø10 Indenter for Brinell test								HBW10/100		

Measurement microscope 40X (**19BAA318**), Measurement microscope 100X (**19BAA319**)

Optional accessories

Item	Order No.
Hardness standard block 32HRB	19BAA028
Hardness standard block 42HRB	19BAA029
Hardness standard block 52HRB	19BAA030
Hardness standard block 62HRB	19BAA031
Hardness standard block 72HRB	19BAA032
Hardness standard block 82HRB	19BAA033
Hardness standard block 90HRB	19BAA034
Hardness standard block 10HRC	19BAA035
Hardness standard block 20HRC	19BAA036
Hardness standard block 30HRC	19BAA037
Hardness standard block 40HRC	19BAA038
Hardness standard block 50HRC	19BAA039
Hardness standard block 60HRC	19BAA040
Hardness standard block 70HRC	19BAA041
Hardness standard block 41HR30N	19BAA042 ●
Hardness standard block 50HR30N	19BAA043 ●
Hardness standard block 60HR30N	19BAA044 ●
Hardness standard block 73HR30N	19BAA045 ●
Hardness standard block 83HR30N	19BAA046 ●
Hardness standard block 75HR15N	19BAA047 ●
Hardness standard block 85HR15N	19BAA048 ●
Hardness standard block 90HR15N	19BAA049 ●
Hardness standard block 32HR30T	19BAA050 ●
Hardness standard block 42HR30T	19BAA051 ●
Hardness standard block 52HR30T	19BAA052 ●
Hardness standard block 62HR30T	19BAA053 ●
Hardness standard block 72HR30T	19BAA054 ●
Hardness standard block 78HR15T	19BAA055 ●
Hardness standard block 82HR15T	19BAA056 ●
Hardness standard block 87HR15T	19BAA057 ●
Diamond indenter (R models)	19BAA072
Diamond indenter (R/S models)	19BAA073
Steel ball indenter 1/16" (ø1.5875)	19BAA074
Steel ball indenter 1/8" (ø3.175)	19BAA075
Steel ball indenter 1/4" (ø6.35)	19BAA076
Steel ball indenter 1/2" (ø12.7)	19BAA077
Control box mounting plate	19BAA295 ▼
5mm diamond indenter	19BAA292 ▼

● Except HR-***MR
▼ HR-500 Series only



264-504 Digimatic mini processor DP-1VR

No connection cable is supplied with the DP-1VR. (Should be ordered separately)

Connection cable (1m)
ARK-600, ATK-600(937386)
HR-500 Series(937387)



810-622 Printer DPU-414

With connection cable
(HR-500: 12AAA804)
Not applicable to HR-100 to -400



06ADV380E USB input tool Direct USB-ITN

For simple data input to PCs

11AAC237 Data processing software

See page 39 for details

810-038
Round table Outside \varnothing 250mm

For large specimens

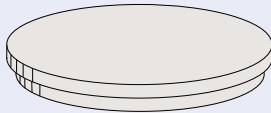

810-037
Round table Outside \varnothing 180mm

For large specimens



810-040
V-anvil (large)
(Outside \varnothing 40mm, groove width 50mm)
For cylindrical specimens
Insert diameter: \varnothing 19mm



810-043
Spot anvil
(Outside \varnothing 12mm)
For sheet specimens
Insert diameter: \varnothing 19mm



810-041
V-anvil (small)
(Outside \varnothing 40mm, groove width 6mm)
For cylindrical specimens
Insert diameter: \varnothing 19mm



810-044
Spot anvil
(Outside \varnothing 5.5mm)
For sheet specimens
Insert diameter: \varnothing 19mm



Note: Optional accessories inside this box cannot be used with AR-10, -20 or -600

810-027
VARI-REST

For testing of long samples

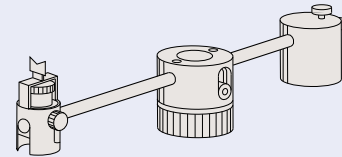

810-029
Special V-anvil
(length: 400mm; groove width: 50mm)
For shafts (max. \varnothing 100mm)

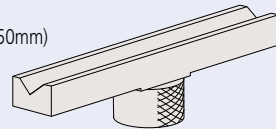

810-026
Fine adjustment table for Jominy test

JIS G 0561
For steel hardenability testing

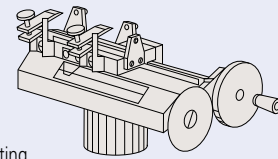

810-030
Diamond-spot anvil
Outside diameter \varnothing 10mm
For sheet specimens
Insert diameter: \varnothing 19mm
For Rockwell Superficial hardness testing



810-042
Small V-anvil
(Outside \varnothing 10mm)
For shafts (max. diameter: 16mm)
Insert diameter: \varnothing 19mm

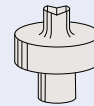

810-028
Jack rest

For testing of long samples
(Used with anvil or round table)

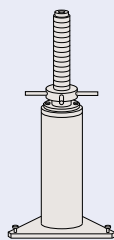

810-643
Vibration isolator

Only for mounting hardness testing machines

810-048
Console table

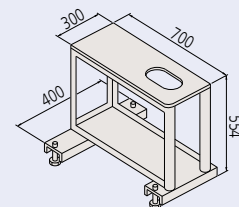

Data processing software for hardness testing machines

As most industrial materials, such as metals, vary in quality, the results of material tests in the property evaluation process and for quality control purposes require accurate statistical analysis. In the case of hardness testing, the results of hardness measurements are processed for statistical calculations, creation of graphs, control charts, and reports for analysis and evaluation for material development and quality control. Such operations and storage of results are performed on PCs. Data processing software connects to a hardness testing machine via a connection cable and transfers the measurement results directly to Excel worksheets on a PC.

This software has the following features:

- ...It can capture measurement results from the hardness testing machine and display them in Excel worksheets.
- ...On the worksheets, the measurement results can be easily converted into table format.
- ...If it is connected to a hardness testing machine that outputs the hardness measurement results and measurement position information together, the hardness distribution on the specimen surface can be displayed graphically. This is very useful in examining the thermal effects of welding, process hardening of the specimen surface, and evaluation of the degree of residual stress.
- ...A standard file suitable for evaluating the carburization hardened layer, a test often used on steel, is supplied.

System configuration

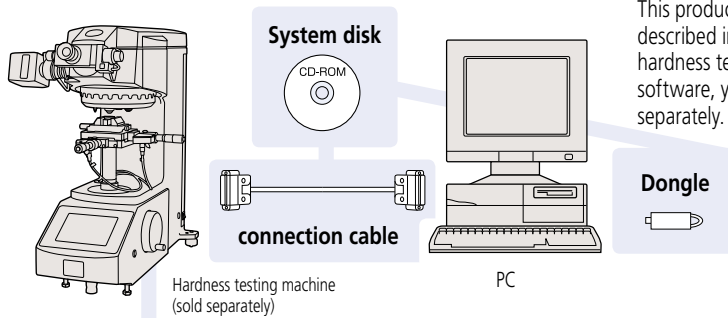

This product consists of the system disk that contains the software as described in the standard configuration, dongle, cables connecting the hardness testing machine and PC, and operation manual. To use this software, you need to purchase a hardness testing machine and PC separately.

Configuration of the data processing software for hardness testing machines

◆ Standard configuration

- Measurement result list
- Statistical calculation (maximum, minimum, standard deviation, variation, mean, coefficient of variation)
- Hardness curve
- Hardness histogram
- 2D hardness distribution
- 3D hardness distribution

◆ Cable specifications

This software includes the cable that connects the hardness testing machine and PC as a standard accessory.
Note: the cable specification varies depending on your PC and hardness testing machine.

◆ Supported models※

Vickers hardness testing machine
HM Series (except HM-101)
HV Series (except HV-101)

Rockwell hardness testing machine
HR-500 Series
Portable hardness tester
HH-411 Series

Specifications

Order No.	Model	Standard configuration	Cable connections		Cable specifications
			Hardness testing machine	Operating environment	
11AAC236	EXPAK-06	<ul style="list-style-type: none"> · Software CD-ROM (includes user's manual) · Connection cable · USB security dongle · Quick reference guide 	HM-210A HM-220A (Cannot be used with Systems B, C or D)	OS: Windows7 SP1(32bit) Application: Office 2010 (Excel 2010) Language: Japanese or English Recommended hardware CPU: Intel i3-2100 processor (3.1 GHz) Memory: 2GB or more Optical drive: CD-ROM drive Required interfaces and no. of ports: 11AAC236: USB, 2 ports 11AAC237, 238: USB, 1 port and RS-232C*, 1 port	USB cable
11AAC237	EXPAK-07		HM-102/103/112/113/114/115 HM-122/123/124/125 HM-211/221 HV-112/113/114/115 (Cannot be used with above models in systems with a PC) HR-511/521/522/523		RS-232C reverse cable 9P-9P
11AAC238	EXPAK-08		HH-411 (UD-410)		Special connection cable 8P-9P

Note: Mitutoyo is unable to provide assurance for use of RS-232C with a commercial USB-RS-232C converter as performance has not been tested

Examples of setting screens

The following are sample screenshots of data processing software for hardness testing machines running within an Excel* worksheet.

* Excel is either a registered trademark or trademark of Microsoft Corporation in the United States and/or other countries

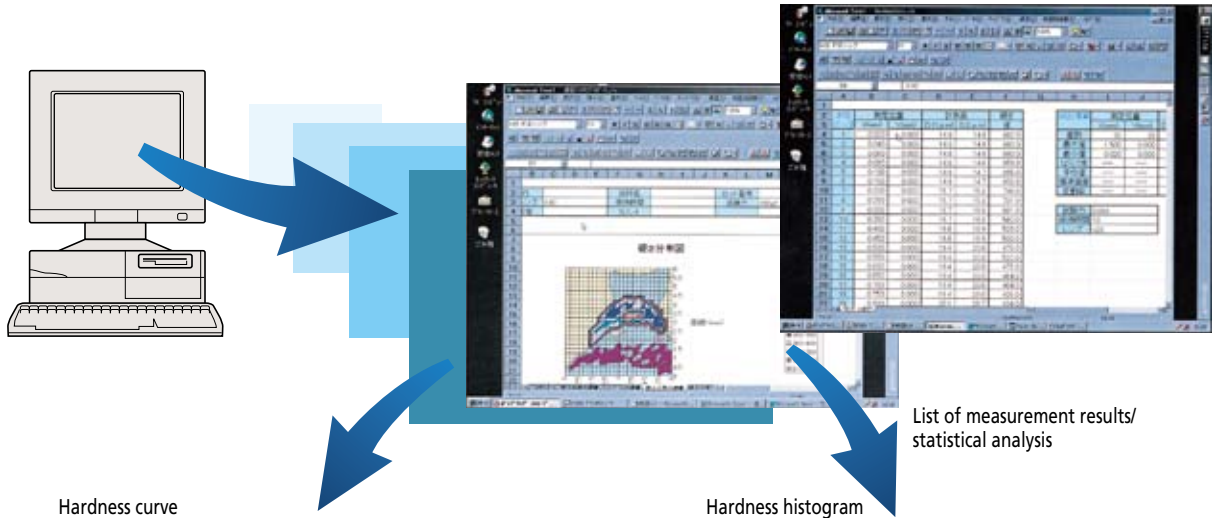

Hardness curve

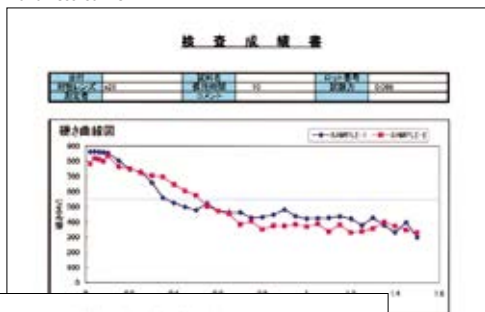

Hardness histogram

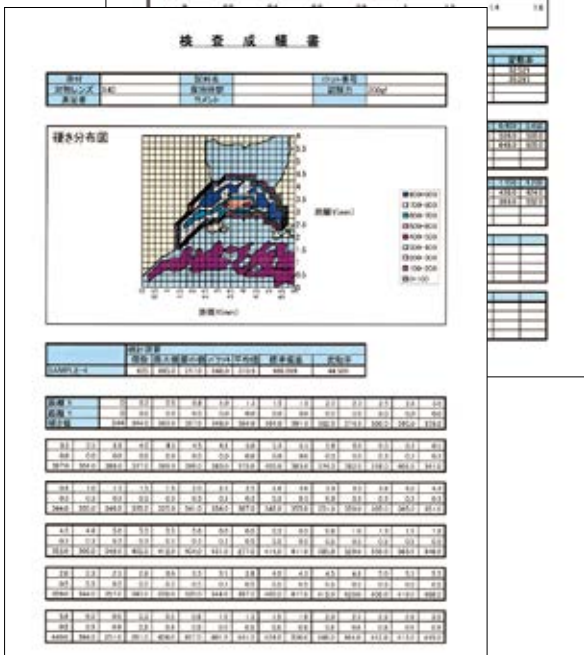
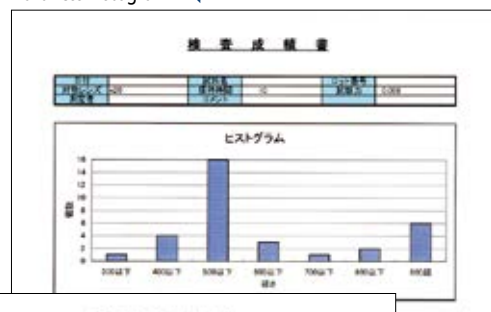

2D hardness distribution

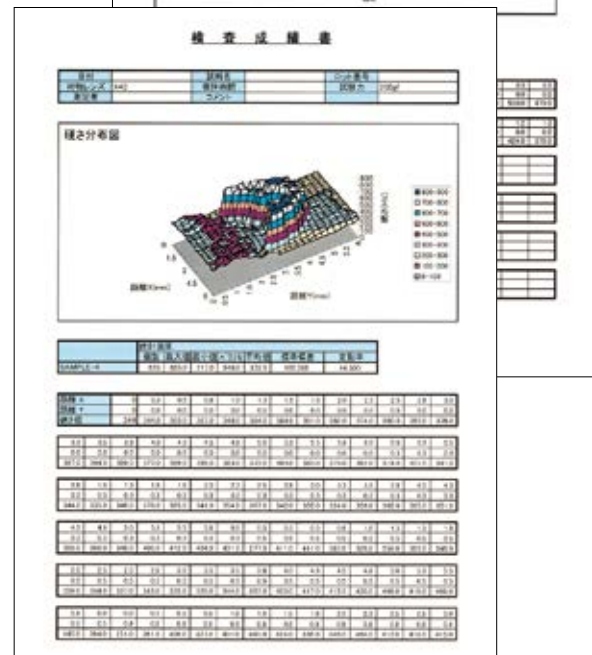

3D hardness distribution* Note: 3D hardness distribution is not a basic function of this product and uses functions of Microsoft Excel software.



Rebound type portable hardness tester

HARDMATIC HH-411

HH-411 is a rebound type portable hardness tester for metal with a compact body and high operability. It allows anyone to perform hardness testing easily at the touch of a key, so it can be used widely on various components in the field.



810-299
HH-411

Rich variety of detectors available

In addition to the general-purpose detector (D type) supplied as standard equipment, the detector lineup includes rich variations (sold separately) to support special applications. The DC type is provided for hardness testing of internal walls of pipes with diameters that cannot be tested with the D type, the D+15 type for bearings and gears, and the DL type for small areas such as the bottom of small gears and weld corners.

Equipped with automatic orientation correction

For the rebound type hardness tester, gravity affects the measurement result depending on the orientation of the detector relative to the vertical when pressed against the specimen surface. The HH-411 is equipped with the latest measurement technology that automatically detects the orientation of the detector to automatically correct for this effect, so maximum accuracy is always achieved.

Hardness testing of small surfaces is possible

Only a small surface (standard D type: $\phi 22\text{mm}$, separately sold DL type: $\phi 4\text{mm}$) area is required for hardness testing. Therefore the HH-411 can be used for testing of various specimen shapes such as around grooves and gear teeth.

Equipped with a data save function

Up to 1800 hardness test results can be saved, which is useful for patrol tests in the field.

Hardness scale can be selected for your own individual purpose

Based on the hardness HL value (L value: according to ASTM A 956), conversion can be performed to Vickers, Brinell, Rockwell C, Rockwell B, and Shore hardness as well as tensile strength.

Conversion can be performed after the test, or hardness value display in the conversion mode is also available.

Great operability

The basic operation is to press the detector against the sample surface and push the detector button by your finger, just like clicking a ballpoint pen, so it is easy for anyone to do.

■ Application examples for each detector type



● DC Type : UD-412



● Hardness testing of internal walls of pipes and tight spaces



● D+15 Type : UD-413



● Hardness testing in gaps and grooves and with slightly uneven surfaces



● DL Type : UD-414



● Small surfaces such as bottom lands of gears and weld corners



Specifications

Order No.	810-298(ASTM) 810-299(JIS)
Model	HH-411
Detector	Carbide ball is used at the tip of the impact hammer (D type: ASTM A956 specification)
Display	7 segments, LCD display
Hardness display range	Leeb hardness :1 to 999HL
Measuring accuracy	800±12HL For measurements performed using a testing method described in the user's manual with a Mitutoyo-recommended test block firmly mounted on a granite surface base
Display range (The display range varies depending on the conversion table used.)	Vickers hardness :43 to 950HV Brinell hardness :20 to 894HB Rockwell hardness (C scale) :19.3 to 68.2HRC Rockwell hardness (B scale) :13.5 to 101.7HRB Shore hardness :13.2 to 99.3HS Tensile strength :499 to 1996MPa
Function	Automatic angle correction Offset Pass or failure decision function Data save: 1800 Points Conversion (details in display range) Statistical calculation function (mean, maximum, minimum, variation, standard deviation) Auto-sleep Dotting count display
Specimen requirements	Min. thickness: 5mm; mass: 5kg or more (However, specimens with a mass between 0.1 and 5kg can be tested if fixed to a strong support.) Test points: At least 5mm from specimen edges and at intervals of at least 3mm Surface roughness: up to Ra 2µm
External connection interface	For printer: Serial interface (compatible with the RS-232C standard), Digimatic interface (1 each; simultaneous output is available)
Power supply	Two AA alkaline batteries (battery life: Approx. 70 hours in continuous use), AC adapter (special accessory)
Operating environment	Temperature: 0 to 50°C Humidity: 95% (No condensation)
External dimensions	Display: Approx. 70(W)×110(D)×35(H)mm Approx. 200g
Mass	Detector: Approx. ø28×175mm 120g

Note: For Shore hardness value measurements in Japan, please use item with order no. 810-299

Standard components

Order No.	Item	Description	Quantity
810-292	Display UD-410	—	1
—	AA alkaline battery	—	2
—	User's manual	—	1
—	Strap	—	1
810-287	Detector UD-411	D type Approx. ø28 x 175mm, Approx. 120g (tip diameter ø22mm)	1
—	Impact hammer	—	1
19BAA457	Carbide ball	Installed in the impact hammer	1
19BAA459	Wrench	For replacement of carbide ball	1
19BAA451	Support ring	ø22mm	1
19BAA452	Support ring (Small)	ø14mm	1
19BAA258	Cleaning brush	—	1
—	Storage case for testing machine	For display and detector	1
19BAA265	Hardness standard block	800HLD-equivalent (ø90mm, t55mm, 2.7kg)	1
—	Storage case for standard blocks	—	1

Note: The HH411 cannot be used for hardness measurement of elastic materials such as rubber. Stiffness of the measurement target may affect the measurement result. Particularly avoid the measurement of sheets.

Optional accessories

Order No.	Item	Description	Quantity
264-504	Digimatic mini processor	Printing of measurement data, various statistical calculations, etc.	1
937387	Connection cable	For connection of DP-1VR and display (1m)	1
09EAA082	Recording paper	For DP-1VR (10 rolls)	1
810-622	Thermal printer DPU-414	Printing, such as the statistical calculation and a variety of measurement data	1
19BAA285	Connection cable (for DPU-414)	With connection cable for display	1
19BAA157	Recording paper	For DPU-414 (TP411-28CL) (10 rolls)	1
19BAA238	Connection cable	For connection of the PC and display RS-232C (For DOS/V PC)	1
526688	AC adapter	For display AD908N	1
19BAA243	Hardness standard block	880HLD (ø115mm, t33mm, 3.7kg)	1
19BAA244	Hardness standard block	830HLD (ø115mm, t33mm, 3.7kg)	1
19BAA245	Hardness standard block	730HLD (ø115mm, t33mm, 3.7kg)	1
19BAA246	Hardness standard block	620HLD (ø115mm, t33mm, 3.7kg)	1
19BAA247	Hardness standard block	520HLD (ø115mm, t33mm, 3.7kg)	1
19BAA248	Support ring cylinder (3)	For measurement of convex surfaces (R10 to 20mm): For D and DC types	1
19BAA249	Support ring hollow cylinder (4)	For measurement of concave surfaces (R14 to 20mm): For D and DC types	1
19BAA250	Support ring sphere (5)	For measurement of convex surfaces (R10 to 27.5mm): For D and DC types	1
19BAA251	Support ring hollow sphere (6)	For measurement of concave surfaces (R13.5 to 20mm): For D and DC types	1
19BAA457	Carbide ball	For D, DC, and D+15 types	1
19BAA458	Replacement ball shaft	For DL type	1
810-287	Detector UD-411	D type Approx. ø28 x 175mm, Approx. 120g (tip ø22mm)	1
810-288	Detector UD-412	DC type Approx. ø22 x 85mm, Approx. 50g (tip ø22mm)	1
810-289	Detector UD-413	D+15 type Approx. ø28 x 190mm, Approx. 130g (tip width ø11mm)	1
810-290	Detector UD-414	DL type Approx. ø28 x 230mm, Approx. 140g (tip width ø4mm)	1

Interchangeable detectors (special accessories)

- One display (UD-410) can be used in combination with various detectors.

810-290 UD-414

Application: Suitable for measuring in grooves and crevices such as are found on gears and weld corners.



810-289 UD-413

Application: Suitable for the measurement of concave parts.



810-288 UD-412

Application: Suitable for the measurement of internal walls of cylinders. The grip is short, which is desirable for maintaining stability in the measurement position.





Durometers for sponge, rubber, and plastic Hardmatic HH-300 Series

The Hardmatic HH-300 Series includes a slim and easy-to-handle long type and a compact type that fits easily in your hand. Both types have 2 types of display specifications, analog and digital.

Long type

HR Series

811-333,334
HH-333, 334

811-337,338
HH-337, 338

811-333,337
HH-334, 338

Compact type

811-331,332
HH-331, 332

811-335,336
HH-335, 336

811-329,330
HH-329, 330

HARD

Plastics

Hard rubbers

General types of rubber

Elastomers

Hard sponges
Soft foams

SOFT

811-019
CTS-101

811-332
HH-332

811-013
CTS-103

811-336
HH-336

Hardmatic HH-300 Series



Measuring hardness just requires pressing the hardness tester against the specimen and reading the indicated value.

Various kinds of sample can be tested for hardness, from soft sponge to hard plastic. Also, various measurement locations on the specimen can be used, such as a flat surface, a hole, or the bottom of a groove. The 10 models of hardness testers in the HH-300 Series support various hardness measurement standards. The Hardmatic HH-300 Series is compliant with the domestic and overseas industrial standards, and can be used as a quality control tool required by the PL regulations and ISO 9000.

Long type



Analog compact type



Digital compact type



Long type HH-331, 332, 333, 334

The long type has a slender cylindrical shape ($\phi 24 \times 85$ mm). Due to this it can measure hardness at the bottom of grooves or holes as well as exposed surfaces. Also, hardness measurement can be performed while keeping your hands and face away from the specimen surface. This is essential when the surface temperature is high: for example immediately after molding.

Compact type HH-329, 330, 335, 336, 337, 338

The compact body fits snugly into your palm for ease of measurement.

Specifications

Order No.	811-329	811-330	811-331	811-332	811-333	811-334
Model	HH-329	HH-330	HH-331	HH-332	HH-333	HH-334
Type	Compact type			Long type		
Display specification	Analog		Digital		Analog	Digital
Measurement target	Soft rubber, sponge, felt, hard foam, winder		General rubber/soft plastic		Hard rubber/hard plastic/ebonite	
Category in standards	Type E			Type A		Type D
Needle shape	—			$\phi 1.25 \pm 0.15$ mm		
Shaft diameter	—			$\phi 1.25 \pm 0.15$ mm		
Tip shape	Semi-sphere		Circular truncated cone		Cone	
Tip angle	—		$35^\circ \pm 0.25^\circ$		$30^\circ \pm 0.5^\circ$	
Tip diameter	$\phi 5 \pm 0.04$		$\phi 0.79 \pm 0.01$ mm		—	
Tip curvature	—		—		0.1 ± 0.01 mm	
Needle platform	44x18mm		$\phi 18$ mm			
Protrusion of needle from platform	2.5mm		2.5mm			
Minimum graduation	1° (HH-329, 331, 333) 0.5° (HH-330, 332, 334)					
Loading device	Coil spring method		Coil spring method		Coil spring method	
W _E , W _A , W _B , spring force (mN)	W _E =550+75H _E		W _A =550+75H _A (H _A : 10 to 90)		W _B =444.5H _B (H _B : 20 to 90)	
H _E , H _A , H _B hardness	(10 scale 1300mN, 90 scale 7300mN)		(10 scale 1300mN, 90 scale 7300mN)		(20° 8890mN, 90° 40005mN)	
Functions	Peak hold	Hold function Output function: Digimatic interface for printer	Peak hold	Hold function Output function: Digimatic interface for printer	Peak hold	Hold function Output function: Digimatic interface for printer
External dimensions	Approx. 56(W)x33.5(D)x144(H)mm	Approx. 60(W)x28.5(D)x151(H)mm	Analog long Approx. 56 (W) x 33.5 (D) x 186 (H) mm Digital long Approx. 60 (W) x 28.5 (D) x 193 (H) mm			
Mass	300g	290g	320g	310g	320g	310g
Power supply	—	Button type silver oxide battery SR44	—	Button type silver oxide battery SR44	—	Button type silver oxide battery SR44
Standard configuration	<ul style="list-style-type: none"> •Hardness tester main unit: 1 •User's manual: 1 •Button type silver oxide battery SR44 (HH-330, 332, 334, 336, 338 only) •Warranty card 					



Hold function HH-330/332/334/336/338

Holds the display value at any time during measurement so that you can easily check the measurement result.



Peak hold function HH-329/331/333/335/337

The peak hold indicator attached to the analog display is very useful for peak value measurement.



Output zero set function HH-330/332/334/336/338

A Digimatic output interface is standard, so they can be connected to the DP-1VR (special accessory) and measurement system. By using the zero set switch, which also serves as the power switch, you can correct any small shift of the zero position due to a quantization error.

Specifications

Order No.	811-335	811-336	811-337	811-338
Model	HH-335	HH-336	HH-337	HH-338
Type	Compact type			
Display specification	Analog	Digital		Digital
Measurement target	General rubber / soft plastic		Hard rubber/hard plastic/ebonite	
Category in standards	Type A		Type D	
Needle shape	Shaft diameter: $\varnothing 1.25 \pm 0.15\text{mm}$			
Tip shape	Circular truncated cone		Cone	
Tip angle	$35^\circ \pm 0.25^\circ$		$30^\circ \pm 0.5^\circ$	
Tip diameter	$\varnothing 0.79\text{mm} \pm 0.01\text{mm}$		—	
Tip curvature	—		$0.1 \pm 0.01\text{mm}$	
Pressure surface shape	$44 \times 18\text{mm}$			
Protrusion of needle from platform	2.5mm			
Minimum graduation	1° (HH-335, 337) 0.5° (HH-336, 338)			
Loading device $W_A, W_D, \text{spring force (mN)}$ $H_A, H_D \text{ hardness}$	Coil spring method $W_A=550+75H_A$ (HA: 10 to 90) (10 scale 1300mN, 90 scale 7300mN)		Coil spring method $W_D=444.5H_D$ (HD: 20 to 90) (20 scale 8890mN, 90 scale 40005mN)	
Functions	Peak hold	Hold function Output function: Digimatic interface for printer	Peak hold	Hold function Output function: Digimatic interface for printer
External dimensions	Approx. 56 (W) x 33.5 (D) x 144 (H)mm Approx. 60 (W) x 28.5 (D) x 151 (H)mm			
Mass	300g	290g	300g	290g
Power supply	—	Button type silver oxide battery SR44	—	Button type silver oxide battery SR44
Standard configuration	•Hardness tester main unit: 1 •User's manual: 1 •Button type silver oxide battery SR44 (HH-336, 338 only) •Warranty card			

One unit for 3 applications

Optional accessories

Measurement/test dual purpose stand CTS Series (all models)

The CTS Series can be combined with the HH-300 Series for (1) hardness measurement, and (2) spring force testing of the HH-300 Series hardness tester main unit. (3) By connecting the attached weight directly to the hardness tester to perform hardness measurement results in better repeatability than can be obtained compared to hardness measurement made by directly pressing the hardness tester against the workpiece by hand. This measurement method with a weight directly connected to the hardness tester is useful for measuring the hardness of large samples for which the stand cannot be used, as well as hardness measurement in the field. The CTS Series includes 4 models for different hardness tester types. All 4 models can be used for 1, 2, and 3 above with one stand by adding a separately available accessory.



Specifications

Order No.	811-019	811-012	811-013	811-014
Model	CTS-101	CTS-102	CTS-103	CTS-104
Applicable model	HH-331, 332	HH-333, 334	HH-335, 336	HH-337, 338
Application 1. Fixed force hardness measurement				
Measurement force	9.81N	49.05N	9.81N	49.05N
Weight used	①	①+③+④	①	①+③+④
Application 2. Manual fixed force hardness measurement				
Measurement force	9.81N	49.05N	9.81N	49.05N
Weights used	①+⑥	①+③+⑥	①+⑥	①+③+⑥
Application 3. Loading test				
Weight used	L:— / H:①	L:①+⑤ / H:③	L:— / H:①+②	L:①+⑤ / H:③
Weights	①CTS-101, 102, 103, 104 Measurement / testing ②103 Measurement ③CTS-102, 104 Measurement / testing ④CTS-102, 104 Measurement ⑤CTS-102, 104 Measurement / testing ⑥CTS-101, 102, 103, 104 Measurement			
Weight application				
Outside diameter (Unit: mm)	①ø64×23.5 ⑥ø40×13	①ø64×23.5 ③ø78×110 ④ø20×25 ⑤ø40×25 ⑥ø40×13	①ø64×23.5 ②ø20×19 ⑥ø40×13	①ø64×23.5 ③ø78×110 ④ø20×25 ⑤ø40×25 ⑥ø40×13
Body mass	①580g ②34.8g ③3950g ④50g ⑤197.4g ⑥130g			
Stand overview	External dimensions ø148 x Height (Max.) 420mm			
Up/down stroke	12mm			
Maximum specimen thickness	Approx. 90mm			
Specimen table dimension	ø90mm			
Total mass	Approx. 9kg	Approx. 13kg	Approx. 9kg	Approx. 13kg

Standard configuration

Item	Usage	Quantity	811-019	811-012	811-013	811-014
			CTS-101	CTS-102	CTS-103	CTS-104
Main unit	—	1	○	○	○	○
Tool set	—	1	○	○	○	○
Weight①	Measurement / testing	1	○	○	○	○
Weight②	Testing	1	—	—	○	—
Weight③	Measurement / testing	1	—	○	—	○
Weight④	Measurement / testing	1	—	○	—	○
Weight⑤	Testing	1	—	○	—	○
Weight⑥	Testing	2	○	○	○	○
User's manual	—	1	○	○	○	○
Warranty card	—	1	○	○	○	○



① Hardness measurement

② Spring force testing

③ Direct application of weight



Examples of hardness measurement performance in various standards

Standard	Designation	Description
JIS K 6253 ISO 7619	A45/15	Hardness measurement is performed with the Type A hardness tester. It indicates that a hardness measurement of 45 is obtained 15 seconds after starting the measurement.
	D70/10	Hardness measurement is performed with the Type D hardness tester. It indicates that a hardness measurement of 70 is obtained 10 seconds after starting the measurement.
JIS K 7215	HDA83	Hardness measurement is performed with the Type A hardness tester. It indicates that a hardness measurement of 83 is obtained.
	HDD56	Hardness measurement is performed with the Type D hardness tester. It indicates that a hardness measurement of 56 is obtained.
ASTM D 2240	A/45/15	Hardness measurement is performed with the Type A hardness tester. It indicates that a hardness measurement of 45 is obtained 15 seconds after starting the measurement.
	D/60/1	Hardness measurement is performed with the Type D hardness tester. It indicates that a hardness measurement of 60 is obtained 1 second after starting the measurement.
ISO 868	A/15:45	Hardness measurement is performed with the Type A hardness tester. It indicates that a hardness measurement of 45 is obtained 15 seconds after starting the measurement.
	D/1:60	Hardness measurement is performed with the Type D hardness tester. It indicates that a hardness measurement of 60 is obtained 1 second after starting the measurement.
DIN 53 505	75Shore A	Hardness measurement is performed with the Shore A hardness tester. It indicates that a hardness measurement of 75 is obtained.
JIS K 6301	Hs (JIS A) 40	Hardness measurement is performed with the JIS A hardness tester. It indicates that a hardness measurement of 40 is obtained.
	Hs (JIS C) 60	Hardness measurement is performed with the JIS C hardness tester. It indicates that a hardness measurement of 60 is obtained.

Domestic and overseas standards

JIS K 6253	"Hardness testing methods for rubber, vulcanized or thermoplastic"
JIS K 6301	"Physical testing methods for rubber, vulcanized or thermoplastic"
JIS K 7215	"Testing Methods for Durometer Hardness of Plastics"
JIS S 6050	"Plastics erasers"
ISO 7619	"Rubber-Determination of indentation hardness by means of pocket hardness meters"
ISO 868	"Plastics and ebonite-Determination of indentation hardness by means of a durometer (Shore hardness)"
ASTM D 2240	"Standard Test Method for Rubber property-Durometer Hardness"
DIN 53 505	"Testing of rubber and plastics; shore A and shore D hardness test"
SRIS 0101	"Physical testing methods for expanded rubber"

Hardness standard block (HH-333/334/337/338)

Hardness standard blocks (based on JIS K 7215/for Type D) are available as useful tools for a daily check of the hardness tester.
To order or for further details, contact the following:

Japanese Chemical Innovation Institute
High Polymer Test & Evaluation Center
2-22-13, Yanagibashi, Taito-ku, Tokyo 111-0052



System configuration

The HH-300 Series can be used more effectively by combining them with various special accessories (sold separately).

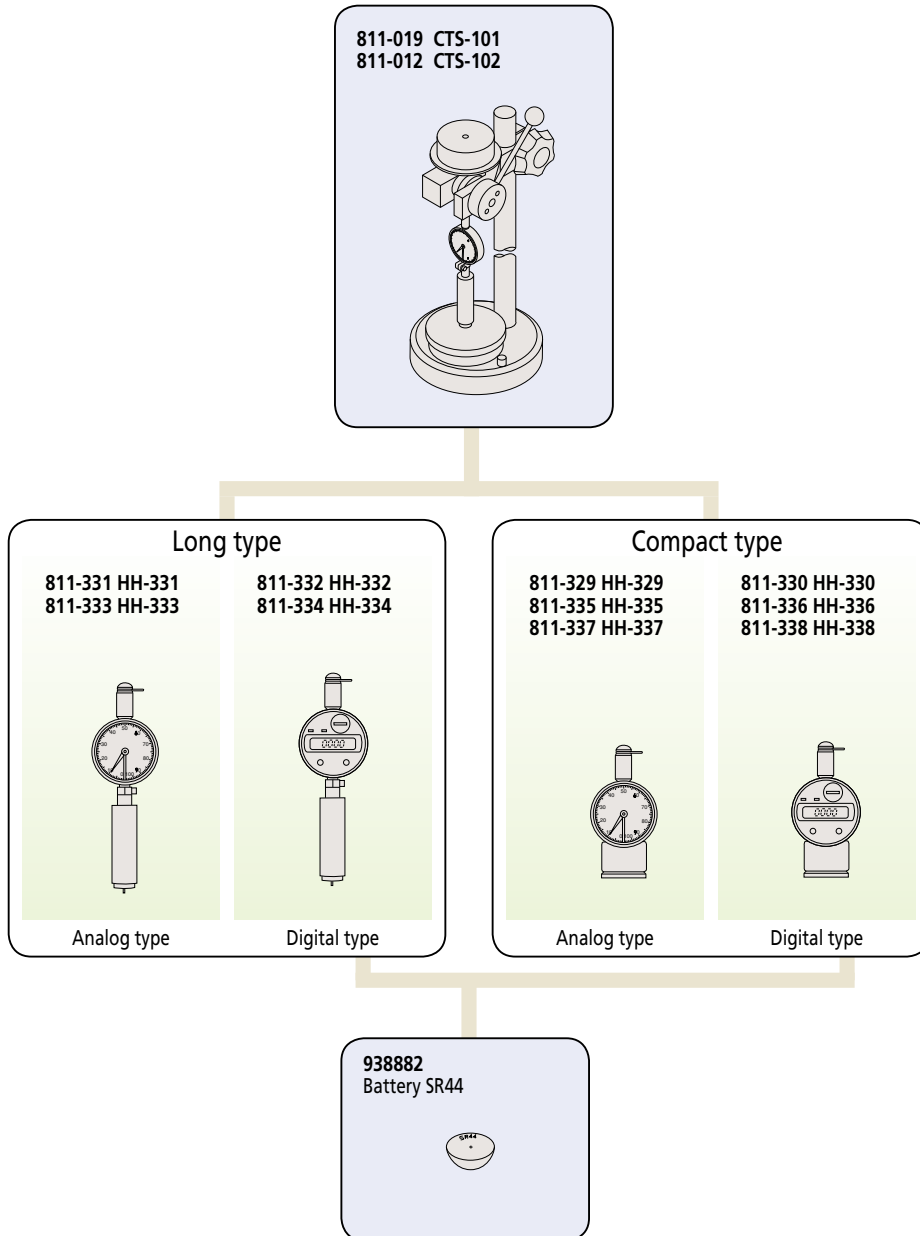

Related information and materials

■ Hardness basics

“Hardness” is a convenient term used broadly in our daily language, but the concept is complicated. Experiencing hard and soft is easy, but it is difficult to express those actual qualities in simple terms. Hardness thus has broad meanings and refers to a measure closely related to one or a number of properties, including resistance to wear, resistance to scratching, elastic modulus, yield point, fracture strength, viscosity, brittleness, and ductility. Hardness testing is localized testing of a material and is therefore easier to perform than testing of other properties like tensile strength, proof stress, spring elastic limit, formability and abrasion resistance. Even after testing, it is often the case that the item can still be used as a product. Therefore testing hardness is often preferred as a practical alternative to testing other characteristics.

Hardness is not a physical quantity like length, time, mass or current, but an industrial quantity or comparison value like other mechanical properties.

The hardness of an object is a measure indicating the level of resistance when the object is subjected to deformation by another object

1. Overview of hardness

Testing methods used to characterize hardness as a numerical value employ diverse methods of applying deformation and resistance representation devised for, and defined by, each of those testing methods. The hardness testing methods used by industry today can be basically grouped as follows according to variations in standard materials, deformations to be used as the basis for measurement, and hardness calculation methods. Indentation testing methods are the most commonly applied. They involve applying a permanent deformation to the test surface and determining its hardness from the test force required to create the deformation and the size of the deformation.

Rebound hardness (or dynamic hardness) testing measures the behavior when a standard impactor is made to collide with the test surface, and scratch hardness testing measures the behavior when two materials are rubbed together. Portable hardness testing employs a different comparative measurement method for each type of material due to priority being placed on ease of operation and even magnetism and ultrasound are used.

Other typical examples of methods for common hardnesses include Mohs hardness and pencil hardness testing, which have been around for many years.

2. Hardness-related standards

Japanese Industrial Standards (JIS) include a number of standards related to hardness. With the recent trend toward internationalization, JIS standards are being revised so they are consistent with ISO standards. The major categories can be grouped as follows.

- Test methods: Specifying the methods to be used for general hardness testing
- Verification of testing machines: Specifying the testing machines to be used for hardness testing
- Calibration of reference blocks: Specifying the methods of calibration of reference blocks to be used for verification of hardness testing machines
- Application-specific test methods: Specifying the hardness testing methods to be used for specific applications.

● Brinell hardness testing

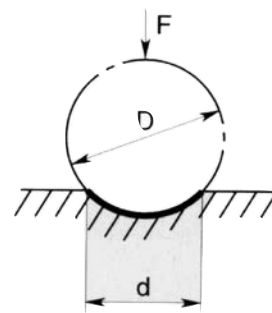

● Vickers hardness testing

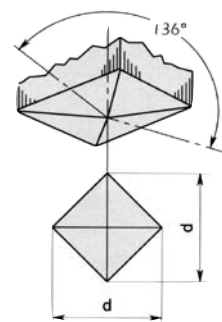

● Rockwell hardness testing

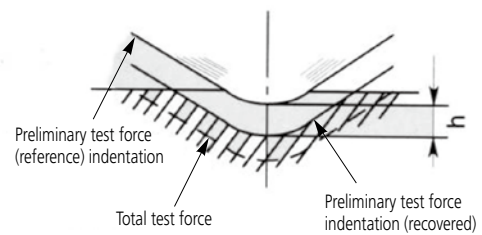

Indentation size for each type of hardness test

Hardness test	Test force	Indentation diameter (mm)	Indentation depth (mm)
Brinell hardness (HB)	29421N	5.5 to 3	1 to 0.5
Rockwell hardness (HRC)	1471N	1 to 0.5	0.06 to 0.015
Rockwell hardness (HRA)	588.4N	0.5 to 0.25	0.04 to 0.01
Rockwell Superficial hardness (HR)	147.1 to 441.3N	0.2 to 0.02	0.02 to 0.001
Vickers hardness (HV)	9.807 to 490.3N	0.7 to 0.05	0.1 to 0.01
	98.07 to 9807mN	0.2 to 0.005	0.03 to 0.001
Shore hardness (HS)		0.3 to 0.6	0.01 to 0.04



■ Hardness definitions and types

Types of "hardness"

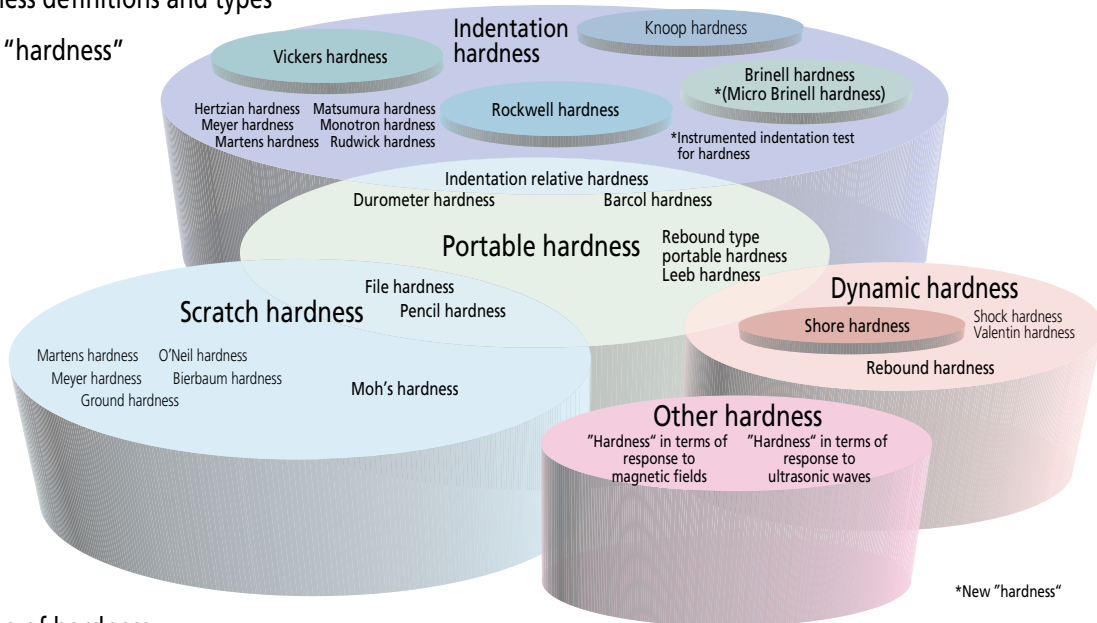

Definition of hardness

(1) Brinell hardness

The Brinell hardness testing method was the first method invented for standardizing hardness, from which other hardness measuring methods have been derived. Brinell hardness is the test force F divided by the contact area S (mm^2) between the spherical indenter and specimen calculated on the diameter d (mm) of the impression made when the indenter (a steel ball or cemented carbide ball with a diameter D mm) is pressed into the sample by the test force F and then removed. The symbol HBS is used when the indenter is a steel ball, or HBW when it is a cemented carbide ball. k is a constant ($1/g = 1/9.80665 = 0.102$).

$$HBW = k \frac{F}{S} = 0.102 \frac{2F}{\pi D (D - \sqrt{D^2 - d^2})} \quad \begin{matrix} F: N \\ D: mm \\ d: mm \end{matrix}$$

For the same loading condition (F/D^2), the Brinell hardness obtained is almost the same when different test forces are used for measurement. In many countries, measurement with small test forces is widespread as an application of this fact. Testing with a test force of 2451N or less can be conducted by using the test force weight and indenter for the Rockwell or Vickers hardness testing machine. For steel, F/D^2 is 30. For other softer materials, an appropriate value is selected from 15, 10, 5, 2.5, 1.25, and 1. In the JIS and ISO standards, the test force is 9.807 to 29420N, and the diameter of the spherical indenter is 1 to 10mm. An error of the Brinell hardness test is obtained by the following formula. Δd^1 indicates the error of the impression measuring device, Δd^2 the error in impression measurement.

$$\frac{\Delta HB}{HB} \approx - \frac{\Delta F}{F} - (0.03 \sim 0.18) \frac{\Delta D}{D} - 2 \frac{\Delta d_1}{d} - 2 \frac{\Delta d_2}{d}$$

(2) Vickers hardness

Vickers hardness is the most versatile test method as it can be used with any test force. More specifically, there are many applications of microhardness below 9.807N. Vickers hardness is the test force F divided by the area S (mm^2) of the indenter and sample calculated based on the diagonal length d (the average of 2 directions in mm) of the impression made when the pyramid-shaped diamond indenter ($\theta = 136^\circ$ between opposite faces) is pressed into the sample by the test force F (N) and then removed.

$$HV = k \frac{F}{S} = 0.102 \frac{F}{S} = 0.102 \frac{2F \sin \frac{\theta}{2}}{d^2} = 0.1891 \frac{F}{d^2} \quad \begin{matrix} F: N \\ d: mm \end{matrix}$$

An error of the Vickers hardness test is obtained by the following formula. Δd^1 indicates the measuring error of the microscope, Δd^2 indicates the error in indentation measurement, " a " indicates the length of the edge line between two opposite faces at the tip of the indenter. $\Delta \theta$ is in degrees.

$$\frac{\Delta HV}{HV} \approx - \frac{\Delta F}{F} - 2 \frac{\Delta d_1}{d} - 2 \frac{\Delta d_2}{d} - \frac{a^2}{d^2} - 3.5 \times 10^{-3} \Delta \theta$$

(3) Knoop hardness

Knoop hardness is the test force F divided by the projected area A (mm^2) of the impression calculated based on the longer diagonal length d (mm) of the indentation made when the pyramid-shaped diamond indenter with apical angles of 130° and $172^\circ 30'$ and rhomboid cross section is pressed into the specimen by the test force F and then removed. Knoop hardness can be measured by replacing the Vickers indenter of the microhardness testing machine with the Knoop indenter.

$$HK = k \frac{F}{A} = 0.102 \frac{F}{A} = 0.102 \frac{F}{cd^2} = 1.451 \frac{F}{d^2} \quad \begin{matrix} F: N \\ d: mm \end{matrix}$$

(4) Rockwell hardness and Rockwell Superficial hardness

A conical diamond indenter with an angle of 120° and a tip radius of 0.2mm tip or spherical indenter (steel or cemented carbide) is used. The preliminary test force is applied first, the test force is applied, and then the preliminary test force is applied again. Rockwell hardness and Rockwell Superficial hardness can be obtained from the hardness calculation formula based on the difference in depths of impression h (μm) measured at the first and second application of the initial test force. The hardness is called Rockwell hardness when the preliminary test force is 98.07N, or Rockwell Superficial hardness when it is 29.42N. Unique symbols are assigned to combinations of types of the indenter, test forces, and hardness calculation formula, which comprise a scale. JIS defines scales of hardness.

Relation diagram for specimen hardness and minimum thickness

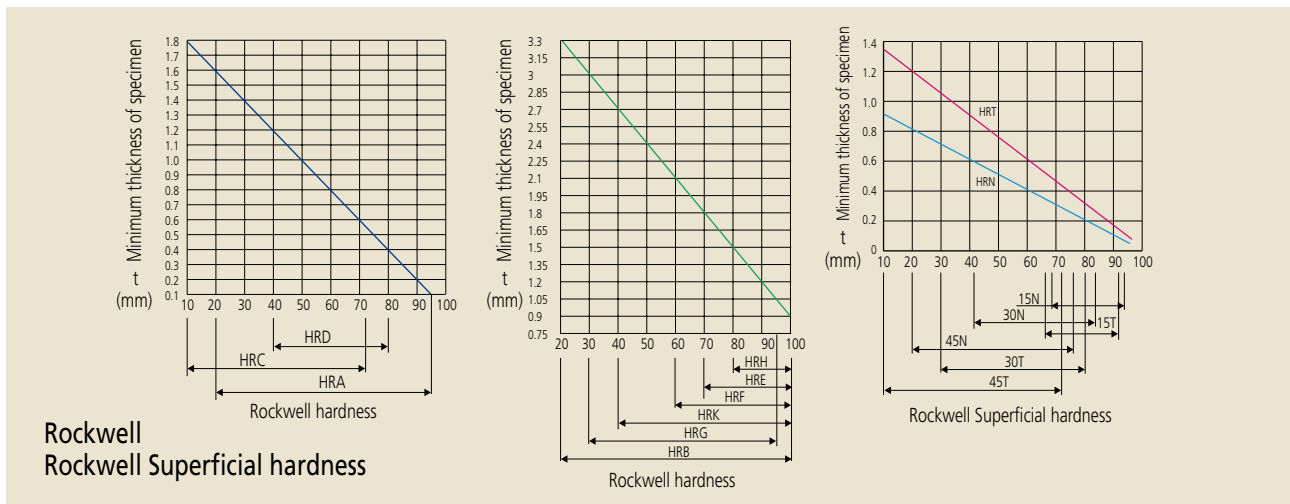
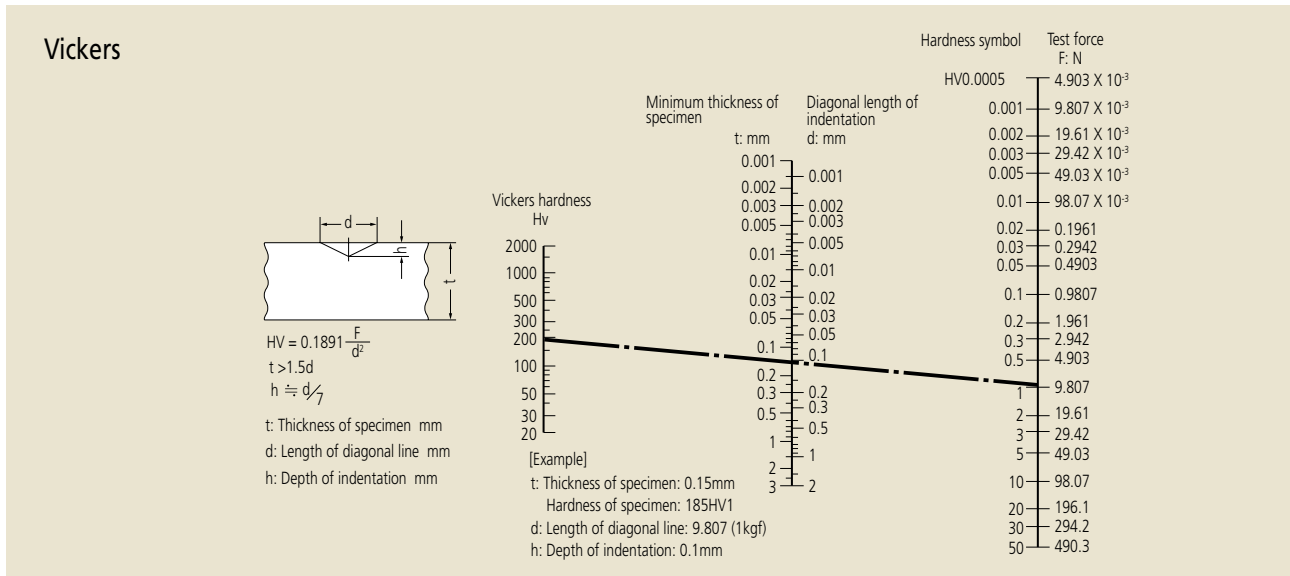

Types of Rockwell hardness

Scale	Indenter	Test force	Application
A	Diamond	588.4N	Carbide, sheet steel
D		980.7N	Case-hardened steel
C		1471N	Steel (100HRB or more to 70HRC or less)
F	Sphere of 1.5875mm diameter	588.4N	Bearing metal, annealed copper
B		980.7N	Brass
G		1471N	Hard aluminum alloy, beryllium copper, phosphor bronze
H	Sphere of 3.175mm diameter	588.4N	Bearing metal, grind stone
E		980.7N	Bearing metal
K		1471N	Bearing metal
L	Sphere of 6.35mm diameter	588.4N	Plastic, lead
M		980.7N	
P		1471N	
R	Sphere of 12.7mm diameter	588.4N	Plastic, lead
S		980.7N	
V		1471N	

Types of Rockwell Superficial hardness

Scale	Indenter	Test force	Application
15-N	Diamond	147.1N	Thin surface-hardened layer on steel such as carburized or nitrided
30-N		294.2N	
45-N		441.3N	
15-T	Sphere of 1.5875mm diameter	147.1N	Sheet of mild steel, brass, bronze, etc.
30-T		294.2N	
45-T		441.3N	
15-W	Sphere of 3.175mm diameter	147.1N	Plastic, zinc, bearing alloy
30-W		294.2N	
45-W		441.3N	
15-X	Sphere of 6.35mm diameter	147.1N	Plastic, zinc, bearing alloy
30-X		294.2N	
45-X		441.3N	
15-Y	Sphere of 12.7mm diameter	147.1N	Plastic, zinc, bearing alloy
30-Y		294.2N	
45-Y		441.3N	

Hardness conversion table

The table below enables conversion between hardness values for metals, which vary according to the particular standard. For accurate results, please use values obtained with the respective testing machines as reference.

Steel

Vickers	Rockwell				Rockwell Superficial			Shore
	HV	HRA	HRB	HRC	HRD	15N	30N	
940	85.6	—	68.0	76.9	93.2	84.4	75.4	98.0
920	85.3	—	67.5	76.5	93.0	84.0	74.8	96.8
900	85.0	—	67.0	76.1	92.9	83.6	74.2	95.6
880	84.7	—	66.4	75.7	92.7	83.1	73.6	94.3
860	84.4	—	65.9	75.3	92.5	82.7	73.1	93.1
840	84.1	—	65.3	74.8	92.3	82.2	72.2	91.7
820	83.8	—	64.7	74.3	92.1	81.7	71.8	90.4
800	83.4	—	64.0	73.8	91.8	81.1	71.0	89.0
780	83.0	—	63.3	73.3	91.5	80.4	70.2	87.6
760	82.6	—	62.5	72.6	91.2	79.7	69.4	86.2
740	82.2	—	61.8	72.1	91.0	79.1	68.6	84.8
720	81.8	—	61.0	71.5	90.7	78.4	67.7	83.3
700	81.3	—	60.1	70.8	90.3	77.6	66.7	81.8
690	81.1	—	59.7	70.5	90.1	77.2	66.2	81.0
680	80.8	—	59.2	70.1	89.8	76.8	65.7	80.2
670	80.6	—	58.8	69.8	89.7	76.4	65.3	79.4
660	80.3	—	58.3	69.4	89.5	75.9	64.7	78.6
650	80.0	—	57.8	69.0	89.2	75.5	64.1	77.8
640	79.8	—	57.3	68.7	89.0	75.1	63.5	77.0
630	79.5	—	56.8	68.3	88.8	74.6	63.0	76.2
620	79.2	—	56.3	67.9	88.5	74.2	62.4	75.4
610	78.9	—	55.7	67.5	88.2	73.6	61.7	74.5
600	78.6	—	55.2	67.0	88.0	73.2	61.2	73.7
590	78.4	—	54.7	66.7	87.8	72.7	60.5	72.8
580	78.0	—	54.1	66.2	87.5	72.1	59.9	72.0
570	77.8	—	53.6	65.8	87.2	71.7	59.3	71.1
560	77.4	—	53.0	65.4	86.9	71.2	58.6	70.2
550	77.0	—	52.3	64.8	86.6	70.5	57.8	69.3
540	76.7	—	51.7	64.4	86.3	70.0	57.0	68.4
530	76.4	—	51.1	63.9	86.0	69.5	56.2	67.5
520	76.1	—	50.5	63.5	85.7	69.0	55.6	66.6
510	75.7	—	49.8	62.9	85.4	68.3	54.7	65.6
500	75.3	—	49.1	62.2	85.0	67.7	53.9	64.7
490	74.9	—	48.4	61.6	84.7	67.1	53.1	63.7
480	74.5	—	47.7	61.3	84.3	66.4	52.2	62.8
470	74.1	—	46.9	60.7	83.9	65.7	51.3	61.8
460	73.6	—	46.1	60.1	83.6	64.9	50.4	60.8
450	73.3	—	45.3	59.4	83.2	64.3	49.4	59.8
440	72.8	—	44.5	58.8	82.8	63.5	48.4	58.8
430	72.3	—	43.6	58.2	82.3	62.7	47.4	57.8
420	71.8	—	42.7	57.5	81.8	61.9	46.4	56.7
410	71.4	—	41.8	56.8	81.4	61.1	45.3	55.7
400	70.8	—	40.8	56.0	81.0	60.2	44.1	54.6
390	70.3	—	39.8	55.2	80.3	59.3	42.9	53.6
380	69.8	(110.0)	38.8	54.4	79.8	58.4	41.7	52.5
370	69.2	—	37.7	53.6	79.2	57.4	40.4	51.4
360	68.7	(109.0)	36.6	52.8	78.6	56.4	39.1	50.3
350	68.1	—	35.5	51.9	78.0	55.4	37.8	49.2
340	67.6	(108.0)	34.4	51.1	77.4	54.4	36.5	48.1
330	67.0	—	33.3	50.2	76.8	53.6	35.2	46.9
320	66.4	(107.0)	32.2	49.4	76.2	52.3	33.9	45.7
310	65.8	—	31.0	48.4	75.6	51.3	32.5	44.6
300	65.2	(105.5)	29.8	47.5	74.9	50.2	31.1	43.4
295	64.8	—	29.2	47.1	74.6	49.7	30.4	42.8
290	64.5	(104.5)	28.5	46.5	74.2	49.0	29.5	42.2
285	64.2	—	27.8	46.0	73.8	48.4	28.7	41.6
280	63.8	(103.5)	27.1	45.3	73.4	47.8	27.9	41.0
275	63.5	—	26.4	44.9	73.0	47.2	27.1	40.4
270	63.1	(102.0)	25.6	44.3	72.6	46.4	26.2	39.7
265	62.7	—	24.8	43.7	72.1	45.7	25.2	38.1
260	62.4	(101.0)	24.0	43.1	71.6	45.0	24.3	37.5
255	62.0	—	23.1	42.2	71.1	44.2	23.2	37.9
250	61.6	99.5	22.2	41.7	70.6	43.4	22.2	37.2
245	61.2	—	21.3	41.1	70.1	42.5	21.1	36.6
240	60.7	98.1	20.3	40.3	69.6	41.7	19.9	36.0
230	—	96.7	(18.0)	—	—	—	—	34.7
220	—	95.0	(15.7)	—	—	—	—	33.4
210	—	93.4	(13.4)	—	—	—	—	32.0
200	—	91.5	(11.0)	—	—	—	—	30.7
190	—	89.5	(8.5)	—	—	—	—	29.4
180	—	87.1	(6.0)	—	—	—	—	28.0
170	—	85.0	(3.0)	—	—	—	—	26.6
160	—	81.7	(0.0)	—	—	—	—	25.2
150	—	78.7	—	—	—	—	—	23.8
140	—	75.0	—	—	—	—	—	22.3
130	—	71.2	—	—	—	—	—	20.8
120	—	66.7	—	—	—	—	—	19.4
110	—	62.3	—	—	—	—	—	17.9
100	—	56.2	—	—	—	—	—	16.3

Brass

Vickers	Rockwell		Rockwell Superficial	
	HV	HRV	HRF	30T 45T
196	93.5	110.0	77.5	66.0
194	—	109.5	—	65.5
192	93.0	—	77.0	65.0
190	92.5	109.0	76.5	64.5
188	92.0	—	—	64.0
186	91.5	108.5	76.0	63.5
184	91.0	—	75.5	63.0
182	90.5	108.0	—	62.5
180	90.0	107.5	75.0	62.0
178	89.0	—	74.5	61.5
176	88.5	107.0	—	61.0
174	88.0	—	74.0	60.5
172	87.5	106.5	73.5	60.0
170	87.0	—	—	59.5
168	86.0	106.0	73.0	59.0
166	85.5	—	72.5	58.5
164	85.0	105.5	72.0	58.0
162	84.0	105.0	—	57.5
160	83.5	—	71.5	56.5
158	83.0	104.5	71.0	56.0
156	82.0	104.0	70.5	55.5
154	81.5	103.5	70.0	54.5
152	80.5	103.0	—	54.0
150	80.0	—	69.5	53.5
148	79.0	102.5	69.0	53.0
146	78.0	102.0	68.5	52.5
144	77.5	101.5	68.0	51.5
142	77.0	101.0	67.5	51.0
140	76.0	100.5	67.0	50.0
138	75.0	100.0	66.5	49.0
136	74.5	99.5	66.0	48.0
134	73.5	99.0	65.5	47.5
132	73.0	98.5	65.0	46.5
130	72.0	98.0	64.5	45.5
128	71.0	97.5	63.5	45.0
126	70.0	97.0	63.0	44.0
124	69.0	96.5	62.5	43.0
122	68.0	96.0	62.0	42.0
120	67.0	95.5	61.0	41.0
118	66.0	95.0	60.5	40.0
116	65.0	94.5	60.0	39.0
114	64.0	94.0	59.5	38.0
112	63.0	93.0	58.5	37.0
110	62.0	92.6	58.0	35.5
108	61.0	92.0	57.0	34.5
106	59.5	91.2	56.0	33.0
104	58.0	90.5	55.0	32.0
102	57.0	89.8	54.5	30.5
100	56.0	89.0	53.5	29.5
98	54.0	88.0	52.5	28.0
96	53.0	87.2	51.5	26.5
94	51.0	86.3	50.5	24.5
92	49.5	85.4	49.0	23.0
90	47.5	84.4	48.0	21.0
88	46.0	83.5	47.0	19.0
86	44.0	82.3	45.5	17.0
84	42.0	81.2	44.0	14.5
82	40.0	80.0	43.0	12.5
80	37.5	78.6	41.0	10.0
78	35.0	77.4	39.5	7.5
76	32.5	76.0	38.0	4.5
74	30.0	74.8	36.0	1.0
72	27.5	73.2	34.0	—
70	24.5	71.8	32.0	—
68	21.5	70.0	30.0	—
66	18.5	68.5	28.0	—
64	15.5	66.8	25.5	—
62	12.5	65.0	23.0	—
60	10.0	63.0	20.5	—
58	—	61.0	18.0	—
56	—	58.8	15.0	—
54	—	56.5	12.0	—
52	—	53.5	—	—
50	—	50.5	—	—
49	—	49.0	—	—
48	—	47.0	—	—
47	—	45.0	—	—
46	—	43.0	—	—
45	—	40.0	—	—

● This conversion table was compiled based on standard SAE J 417. ● Shore hardness follows JIS B 7731.

Related information and materials

Related hardness standards

JIS	Name	Hardness used (scale)
A 1126-07	Method of test for content of soft particles in coarse aggregate by scratching	
B 7724-99	Brinell hardness test – Verification of testing machines	HB
B 7725-10	Vickers hardness test – Verification and calibration of testing machines	HV
B 7726-10	Rockwell hardness test – Verification and calibration of testing machines	HR
B 7727-00	Shore hardness test – Verification of testing machines	HS
B 7730-10	Rockwell hardness test – Calibration of standard blocks	HR
B 7731-00	Shore hardness test – Calibration of standard blocks	HS
B 7734-97	Knoop hardness test – Verification of testing machines	HV, HK
B 7735-10	Vickers hardness test – Calibration of standard blocks	HV
B 7736-99	Brinell hardness test – Calibration of standard blocks	HB
D 4421-96	Hardness test method for brake linings, pads and clutch facings of automobiles	HRM, HRR, BRS, HRV
G 0557-06	Methods of measuring case depth hardened by carburizing treatment for steel	HV
G 0558-07	Steels – Determination of depth of decarburization	HV, 15N, 30N
G 0559-08	Steel – Determination of case depth after flame hardening or induction hardening	HV, HRC
G 0561-11	Method of hardenability test for steel (End quenching method)	HV, HRC
G 0562-93	Method of measuring nitrided case depth for iron and steel	HV, HK
G 0563-93	Method of measuring surface hardness for nitrided iron and steel	HV, HK, HR15N, HS
H 0511-07	Titanium – Sponge titanium – Test methods for Brinell hardness	HB
K 6250-06	Rubber – General procedures for preparing and conditioning test pieces for physical test methods	A, D
K 6253-1-12	Rubber, vulcanized or thermoplastic – Determination of hardness – Part 1: General guidance	A, D
K 6253-3-12	Rubber, vulcanized or thermoplastic – Determination of hardness – Part 3: Durometer method	
K 6253-5-12	Rubber, vulcanized or thermoplastic – Determination of hardness – Part 5: Calibration and verification	
K 7060-95	Testing method for barcol hardness of glass fiber reinforced plastics	
K 7202-2-01	Plastics – Determination of hardness – Part 2: Rockwell hardness	HRR, HRL, HRM, HRE
K 7215-86	Testing Methods for Durometer Hardness of Plastics	HDA, HDD
R 1607-10	Testing methods for fracture toughness of fine ceramics at room temperature	Kc
S 6050-08	Plastics erasers	
Z 2101-09	Methods of test for woods	HB
Z 2243-08	Brinell hardness test – Test method	HB
Z 2244-09	Vickers hardness test – Test method	HV
Z 2245-11	Rockwell hardness test – Test method	HR
Z 2246-00	Shore hardness test – Test method	HS
Z 2251-09	Knoop hardness test – Test method	HV, HK
Z 2252-91	Test methods for Vickers hardness at elevated temperatures	HV
Z 3101-90	Testing Method of Maximum Hardness in Weld Heat - Affected Zone	HV
Z 3114-90	Method of Hardness Test for Deposited Metal	HV, HRB, HRC
Z 3115-73	Method of Taper Hardness Test in Weld Heat - Affected Zone	HV

Note: Standard numbers/names may be different due to revision of the standards.

Coordinate Measuring Machines	11
Vision Measuring Systems	12
Form Measurement	13
Optical Measuring	14
Sensor Systems	15
Test Equipment and Seismometers	16
Digital Scale and DRO Systems	17
Small Tool Instruments and Data Management	18

Mitutoyo Europe GmbH
Borsigstr. 8-10
41469 Neuss
T +49 (0)21 37-102-0
F +49 (0)21 37-102-351
info@mitutoyo.eu
www.mitutoyo.eu

Note: Product illustrations are without obligation. Product descriptions, in particular any and all technical specifications, are only binding when explicitly agreed upon.
MITUTOYO is either registered a trademark or a trademark of Mitutoyo Corp. in Japan and/or other countries/regions.
Other product, company and brand names mentioned herein are for identification purposes only and may be the trademarks of their respective holders.

Mitutoyo