

Profile Projectors



Microscopes



MF-B3017D



MF-UE2017D



INDEX

Profile Projectors

PJ-A3000 Series 302-Vertical	I-2,3
PJ-H30 Series 303-High Accuracy	I-4,5
PV-5110 Series 304	I-6,7
PH-A14 Series 172	I-8,9
PH-3515F Series 172	I-10,11
Accessories for Profile Projectors	I-12
Micrometer Heads for Profile Projectors and Toolmakers' Microscopes	I-12

Workpiece Fixtures for Profile Projectors and Measuring Microscopes	I-13
---	------

Microscopes

TM-505B/1005B Series 176 Toolmakers' Microscopes	I-14
MF Series 176 Measuring Microscopes	I-15,16
MF Series 176 Motorized Type	I-17
MF-U Series 176 High-power Multi-function	I-18,19
MF-U Series 176 Motorized Type Universal	I-20
Accessories for Measuring Microscope	I-21,22
QM-Data200 Series 264-2-D Data Processing Unit	I-23,24
Vision Unit-Series 359-Vision System Retrofit	I-25
FS-70 Series 378-For Semiconductor Inspection	I-26
VMU Series 378-Video Unit	I-27
Eyepieces Series 378	I-28
Objectives Series 378	I-28-32
MSM-400 Series 377- Stereo	I-33-36
Pocket Magnifiers Series 183	I-37
Pocket Comparators Series 183	I-37
Zoom Loupe Series 183	I-37
Clear Loupe Series 183	I-37
Quick Guide to Precision Microscopes	I-38-40

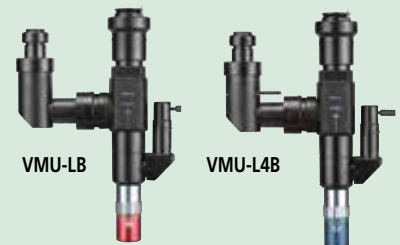

VMU-LB

VMU-L4B

PJ-A3000

SERIES 302 — Vertical Profile Projectors

FEATURES

- The PJ-A3000 Series vertical profile projectors are medium-size 11.8" (300mm) models that feature high versatility and easy operation.
- Easy-to-read digital XY counter is located near the projection screen to minimize eye movement.
- Digital readout protractor screen facilitates angle measurement.



PJ-A3010F-200



PJ-A3005D-50



PJ-A3010F-100



PJ-A3005F-150



PJ-A3010F-200

Projection Capacity

D1: Max. workpiece diameter whose edge line can be focused on the screen center
 D2: Max. workpiece diameter whose edge line can be focused on the screen line

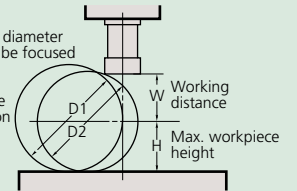

	Magnification			
	10X	20X	50X	100X
View field	ø31.5	ø15.7	ø6.3	ø3.1
W	66 (20)	32.5 (2)	12.6	5
H	-50 models*	123.5	123.5	123.5
	-100 models	91	91	91
	-150 models	103.5	103.5	103.5
	200 models	92.5	92.5	92.5
D1	-50 models*	224 (198)	87 (61)	27
	-100 models	182	87 (61)	27
	-150 models	207 (198)	87 (61)	27
	200 models	185	87 (61)	27
D2		154 (120)	69 (23)	25

(): When using surface illumination

Optional Accessories

- 172-202:** 10X projection lens set (Standard accessory)
- 172-203:** 20X projection lens set
- 172-223:** 10X projection lens
- 172-224:** 20X projection lens
- 172-204:** 50X projection lens
- 172-207:** 100X projection lens
- 172-229:** Oblique illumination mirror for 10X lens
- 172-230:** Oblique illumination mirror for 20X lens
- 172-116:** Standard scale (50mm)
- 172-117:** Standard scale (2")
- 172-118:** Reading scale (200mm)
- 172-161:** Reading scale (300mm)
- 172-119:** Reading scale (8")
- 172-162:** Reading scale (12")
- 172-160-2:** Green filter (for PJ-A3000, -50 models)
- 172-160-3:** Green filter (for -100, -150, -200 models)
- 512305:** Halogen bulb (24V, 150W)
- 383876:** Vinyl cover (standard accessory)

Fixture and Stage Accessories

- 176-106:** Rotary table (Effective diameter: 66mm)
- 172-196:** Rotary table (Effective diameter: 100mm)
- 172-198:** Rotary table with fine feed wheel (Effective diameter: 4" / 100mm)
- 176-105:** Swivel center support (Max. workpiece dia.: 2.7" / 70mm)
- 172-197:** Swivel center support (Max. workpiece dia.: 3.1" / 80mm)
- 176-107:** Holder with clamp
- 172-378:** V-block with clamp (Max. workpiece dia.: 1" / 25mm)
- 999678:** Fixture mount adapter
- 64PMI167:** Stand 22.4 x 20 x 32" (WxDxH)

Availability	PJ-A3005D-50	PJ-A3005F-150	PJ-A3010F-100 PJ-A3010F-200
176-106	✓	✓	
172-196		✓	✓*
172-198		✓	✓*
176-105	✓		
172-197		✓	✓*
176-107	✓	✓	✓*
172-378	✓	✓	✓*

* Fixture mount adapter (999678) is required for PJ-3010F-200



QM-Data200

- 264-155A:** Stand-mount type
- 264-156A:** Arm-mount type
- 2-D data processing unit.
- (Refer to page I-23 for more details.)

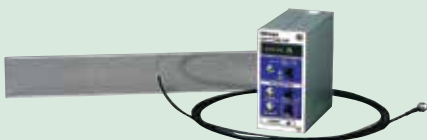

- 332-151:** Optoeye
Edge detection system for QM-Data200
- 12AAE671:** Detector Attachment

SPECIFICATIONS

		Model	PJ-A3010F-200	PJ-A3005F-150	PJ-A3010F-100	PJ-A3005D-50
		Order No.	302-701A	302-702A	302-703A	302-704A
Projected image		Inverted image				
Protractor screen	Effective diameter	12.4" / 315mm				
	Screen material	Fine ground glass				
	Reference line	Cross hair line				
	Angle display (LED)	Resolution: 1° or 0.01° (switchable), Range: ±360° Functions: Absolute/incremental mode switching, Zero Set				
Projection lens		Standard Accessory 10X (172-202)				
Magnification accuracy	Contour illumination	±0.1% or less				
	Surface illumination	±0.15% or less				
Contour illumination	Light source	Halogen bulb (24V, 150W)				
	Optical system	Telecentric system				
	Functions	2-stage brightness switch, Heat-absorbing filter				
Surface illumination	Light source	Halogen bulb (24V, 150W)				
	Optical system	Vertical illumination with a half-reflection mirror				
XY range		8" x 4" (200 x 100mm)	6" x 2" (150 x 50mm)	4" x 4" (100x100mm)	2" x 2" (50 x 50mm)	
Resolution		.0001" / 0.001mm	.0001" / 0.001mm	.0001" / 0.001mm	.0001" / 0.001mm	
Measuring Unit		Built-in linear scales	Built-in linear scales	Built-in linear scales	Digimatic mic heads	
Table size		14.96x9.84" (380x250mm)	11.02x5.98" (280x152mm)	9.84x9.84" (250x250mm)	5.98x5.98" (152x152mm)	
Effective table area		10.47x6.69" (266x170mm)	7.24x3.23" (184x82mm)	5.6x5.6" (142x142mm)	3.23x3.23" (82x82mm)	
Max. workpiece height		3.64" (92.5mm)	4.07" (103.5mm)	3.58" (91mm)	4.86" (123.5mm)	
Functions		± direction switching, SPC output zero-setting	Zero-setting, ± direction switching, SPC output	Zero-setting, ± direction switching, SPC output	± direction switching, SPC output zero-setting	
Power supply		120V AC, 50/60Hz				
Mass		308 lbs. (140kg)	255 lbs. (116kg)	246 lbs. (112kg)	235 lbs. (107kg)	
Standard accessories		10X projection lens set, masking shield, power cord, halogen bulb, fuse, grounding wire, allen wrench, vinyl cover				

DIMENSIONS

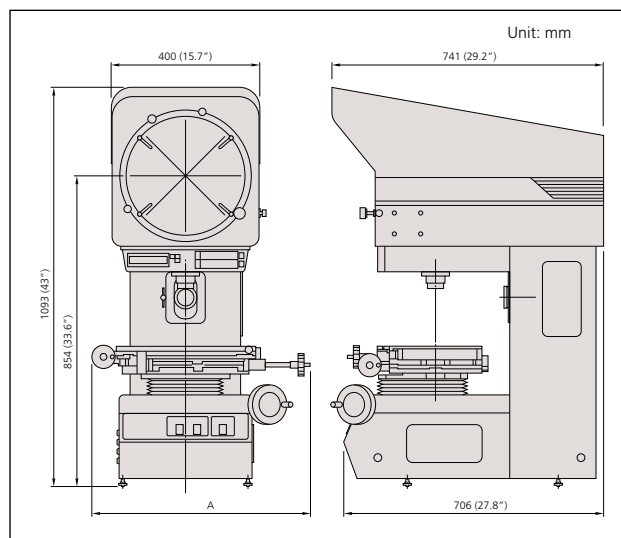

Model	PJ-A3005D-50	PJ-A3010F-100	PJ-A3005F-150	PJ-A3010F-200
A	17.9" / 455mm	16.8" / 427mm	17.6" / 446mm	23.3" / 593mm

PJ-H30

SERIES 303 — High-Accuracy Profile Projectors

By separating axial motion, and stabilizing the XY measuring table in the vertical direction, high measuring accuracy of $(3+0.02L)\mu\text{m}$ has been achieved on the PJ-H30 Series Profile Projectors. Focusing is accomplished by moving the screen head itself up and down with the hand wheel or motorized unit. The power focusing (PJ-H30D type) provides higher performance.

FEATURES

- Newly designed optical system with high NA lenses provides drastically brighter and clearer screen images during surface illumination.
- The three-lens mounting turret includes a 10X lens as standard. Four types of projection lenses (5X, 20X, 50X, 100X) are available.



Switchable surface illumination: vertical or oblique

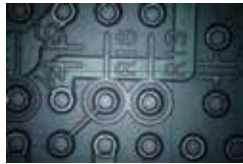

Vertical illumination

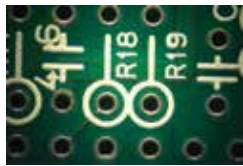

Oblique illumination



PJ-H30A3017B

XY stage travel range: 12x7" / 300x170mm

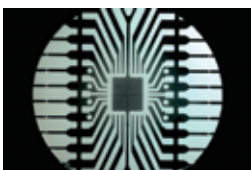
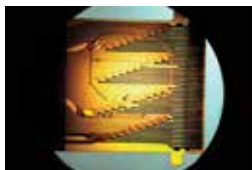
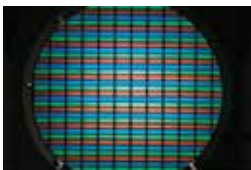

Projection Capacity

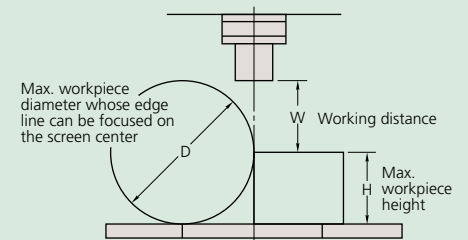

Unit: mm

	Magnification				
	5X	10X	20X	50X	100X
View field	ø61.2	ø30.6	ø15.3	ø6.12	ø3.06
H	100	100	100	100	100
W	66	70.5	56.5	50	50
D	148	197	137	114	114

Optional Accessories

172-271:	5X projection lens
172-472:	10X projection lens (standard accessory)
172-473:	20X projection lens
172-474:	50X projection lens
172-475:	100X projection lens
172-116:	Standard scale (50mm)
172-117:	Standard scale (2")
172-118:	Reading scale (200mm)
172-161:	Reading scale (300mm)
172-119:	Reading scale (8")
172-162:	Reading scale (12")
12AAG981:	Green filter
172-269:	Machine stand
512305:	Halogen bulb (24V, 150W) (standard accessory)
383876:	Vinyl cover (standard accessory)

Fixture and Stage Accessories

172-198:	Rotary table (Effective diameter: 4" / 100mm)
176-305:	Rotary table (Effective diameter: 7.2" / 183mm)
176-306:	Rotary table (Effective diameter: 9.4" / 240mm)
176-105:	Swivel center support (Max. workpiece dia.: 2.8" / 70mm)
172-197:	Swivel center support (Max. workpiece dia.: 3.1" / 80mm)
176-107:	Holder with clamp
172-378:	V-block with clamp (Max. workpiece dia.: 1" / 25mm)
176-317:	Fixture mount adapter C
176-304:	Fixture mount adapter A

Availability	Models	
	PJ-H30A1010B	PJ-H30A2017B
	PJ-H30B1010B	PJ-H30B2017B
	PJ-H30D1010B	PJ-H30D2017B
	PJ-H30A2010B	PJ-H30A3017B
	PJ-H30B2010B	PJ-H30B3017B
	PJ-H30D2010B	PJ-H30D3017B
172-198	✓**	✓****
176-305	✓**	
176-306		✓****
176-107 *	✓**	✓****
172-378 *	✓**	✓****
172-197 *	✓**	✓****
176-105	✓***	✓***

*: Able to attach to a Rotary table (172-198 or 176-305)
 **: Fixture mount adapter C (176-317) is required.
 ***: Rotary table (172-198) is required.
 ****: Fixture mount adapter A (176-304) is required.

QM-Data200

264-155A: Stand-mount type
264-156A: Arm-mount type*
 *Attachment stand (12AAG982) is required.
 2-D data processing unit.
 (Refer to page I-23 for more details.)

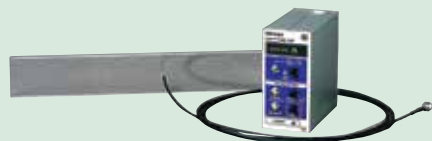

332-151:	Optoeye Edge detection system for QM-Data200
12AAE671:	Detector Attachment

Manual Focus type	Model No.	PJ-H30A1010B	PJ-H30A2010B	PJ-H30A2017B	PJ-H30A3017B
	Order No.	303-712-1A	303-713-1A	303-714-1A	303-715-1A
Power Focus, built-in OPTOYE type	Model No.	PJ-H30D1010B	PJ-H30D2010B	PJ-H30D2017B	PJ-H30D3017B
	Order No.	303-732-1A	303-733-1A	303-734-1A	303-735-1A
Projected Image	Erect image				
Protractor screen	Effective diameter	12" / 306mm			
	Screen material	Fine ground glass			
	Reference line	Cross hair line			
	Screen rotation	±360°, fine feed and clamp			
	Angle display (LED)	Resolution: 1° or 0.01° (switchable), Range: ±370°, Functions: Absolute/incremental mode switching, Zero set			
Projection lens	Standard accessory: 10x (172-472), Optional accessories: 2X, 5X, 20X, 50X, 100X				
Lens mount	3-lenses mounting turret				
Magnification accuracy	Contour illumination	±0.1% or less			
	Surface illumination	±0.15% or less			
Contour illumination	Light source	Halogen bulb (24V 150W)			
	Optical system	Zoom telecentric system			
	Functions	Brightness adjustment, Heat-absorbing filter, Cooling fan			
Surface illumination	Light source	Halogen bulb (24V 150W)			
	Optical system	Vertical / Oblique illumination with an adjustable condenser lens			
	Functions	Non-stepped brightness adjustment, Heat-absorbing filter, Cooling fan			
	XY Range	4 x 4" 100 x 100mm	8 x 4" 200 x 100mm	8 x 6.7" 200 x 170mm	12 x 6.7" 300 x 170mm
	Resolution	.0001" / 0.001mm			
Measuring unit	Built-in Linear scale				
Table size		11.8 x 9.4" 300 x 240mm	13.8 x 11" 350 x 280mm	16.1 x 13.5" 410 x 342mm	20 x 13.5" 510 x 342mm
	Effective table area	7.1 x 5.9" 180 x 150mm	9.8 x 5.9" 250 x 150mm	10.6 x 9.4" 270 x 240mm	14.6 x 9.4" 370 x 240mm
Max. workpiece ht.	4.1" / 105mm				
Max. workpiece load	22lbs / 10kg	22lbs / 10kg	44 lbs / 20kg	44 lbs / 20kg	
Power supply	120V AC, 50/60Hz				
Mass	391lbs / 176kg	396lbs / 178kg	556lbs / 205kg	471lbs / 212kg	
Standard accessories	10X projection lens set, masking shield, power cord, halogen bulb, tube fuse, grounding wire, allen wrench, vinyl cover				

DIMENSIONS

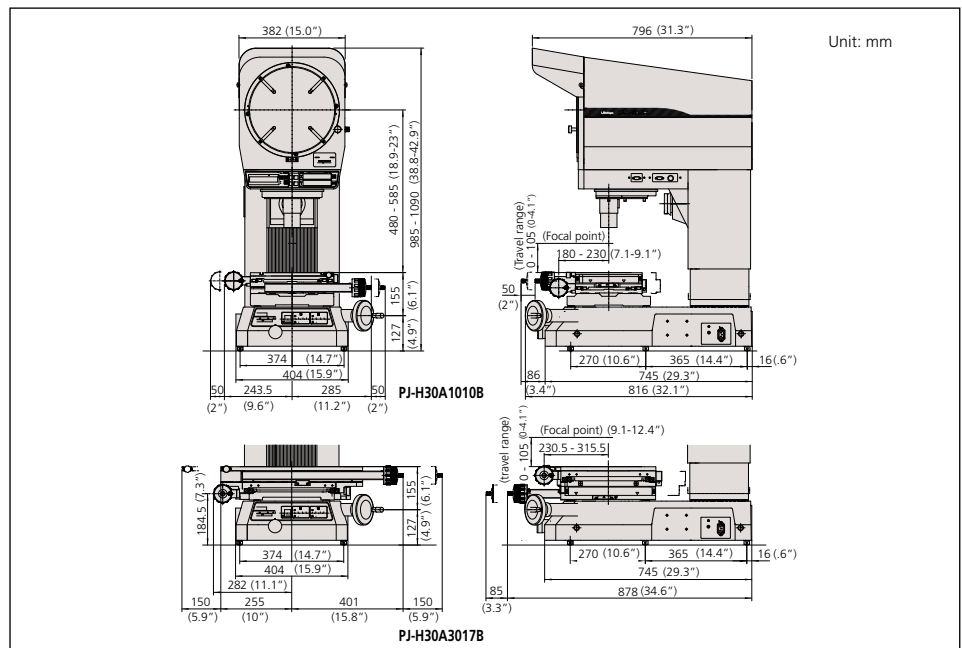

PV-5110

SERIES 304 — Profile Projectors

FEATURES

- Large 500mm screen
- Floor model uses a downward illumination system.
- Digital readout protractor screen (including zero-setting, ABS/INC coordinate switching functions) for easy and error-free angle measurement.
- Angled screen allows projected images to be easily traced or compared with a template.
- The oblique surface illumination system provides clear and bright images, allowing easy inspection of non-reflective workpieces such as plastic parts or printed materials.



PV-5110



PV-5110

Projection Capacity

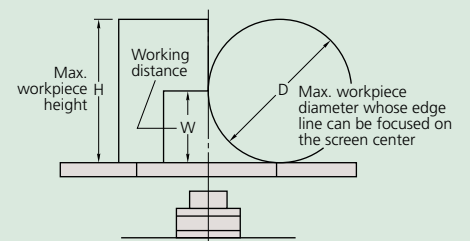

Unit: mm

	Magnification				
	5X	10X	20X	50X	100X
View field	ø101.6	ø50.8	ø25.4	ø10.16	ø5.08
H	125	181	206	87	87
W	60 (27)	60	60	32.4	22.5
D	120	120	120	64.8	45

(): When using surface illumination

Optional Accessories

- 172-401: 5X projection lens set
- 172-406: 5X projection lens
- 172-402: 10X projection lens set (standard accessory)
- 172-409: 10X projection lens
- 172-403: 20X projection lens set
- 172-411: 20X projection lens
- 172-404: 50X projection lens set
- 172-413: 50X projection lens
- 172-405: 100X projection lens set
- 172-415: 100X projection lens
- 172-422: Surface illumination unit (standard accessory)
- 172-116: Standard scale (50mm)
- 172-117: Standard scale (2")
- 172-118: Standard scale (200mm)
- 172-119: Standard scale (8")
- 172-161: Reading scale (300mm)
- 172-329: Reading scale (600mm)
- 172-162: Reading scale (12")
- 172-160-2: Green filter (standard accessory)
- 172-319: Canopy
- 512305: Halogen bulb (24V, 150W) (standard accessory)
- 510189: Vinyl cover (standard accessory)

Fixture and Stage Accessories

- 172-196: Rotary table*
(Effective diameter: 4" / 100mm)
- 172-198: Rotary table with fine feed wheel*
(Effective diameter: 4" / 100mm)
- 172-197: Swivel center support*
(Max. workpiece dia.: 3.1" / 80mm)
- 176-107: Holder with clamp*
- 172-378: V-block with clamp*
(Max. workpiece dia.: 1" / 25mm)

*Fixture mount adapter (999678) is required.



KA Counter (174-183A)

(Refer to page H-7 for more details.)



QM-Data200

- 264-155A: Stand-mount type
 - 264-156A: Arm-mount type
- 2-D data processing unit.
(Refer to page I-23 for more details.)



- 332-151: Optoeye
Edge detection system for QM-Data200
- 12AAE672: Detector Attachment (B)

SPECIFICATIONS

Model No.	PV-5110	
Order No.	304-919A	
Projected image	Invert image	
Protractor screen	Effective diameter	20" / 508mm
	Screen material	Fine ground glass
	Reference line	Cross hair line
	Screen rotation	±360°, fine feed and clamp
	Angle display (LED)	Resolution: 1" or 0.01" (switchable), Range: ±370°, Functions: Absolute/incremental mode switching, Zero set
Projection lens	Standard accessory: 10x(172-472), Optional accessories: 5X, 20X, 50X, 100X	
Magnification accuracy	Contour illumination	±0.1% or less
	Surface illumination	±0.15% or less
Contour illumination	Light source	Halogen bulb (24V 150W)
	Optical system	Zoom telecentric system
	Functions	2-step brightness switch, Heat-absorbing filter, Cooling fan
Surface illumination	Light source	Halogen bulb (24V 150W)
	Optical system	Vertical illumination
	Functions	Adjustable condenser lens. Oblique illumination (for 5X, 10X, and 20X), 2-step brightness switch, Heat-absorbing filter, Cooling fan
	XY Range	8 x 4" / 200 x 100mm
	Resolution	.0001" / 0.001mm*
Measuring unit	Built-in Linear scale	
Table size	15 x 9.8" / 380 x 250mm	
Effective table area	10.5 x 6.7" / 266 x 170mm	
Max. workpiece height	See (H) on page I-6	
Max. workpiece load	11lbs / 5kg	
Power supply	120V AC, 50/60Hz	
Mass	467lbs / 210kg	
Standard accessories	200x100mm (8" x 4") stage, 10X projection lens set, Surface illumination unit. Counter stand for KA counter, power cord, halogen bulb, fuse, grounding wire, allen wrench, vinyl cover	

* Counter not included

DIMENSIONS

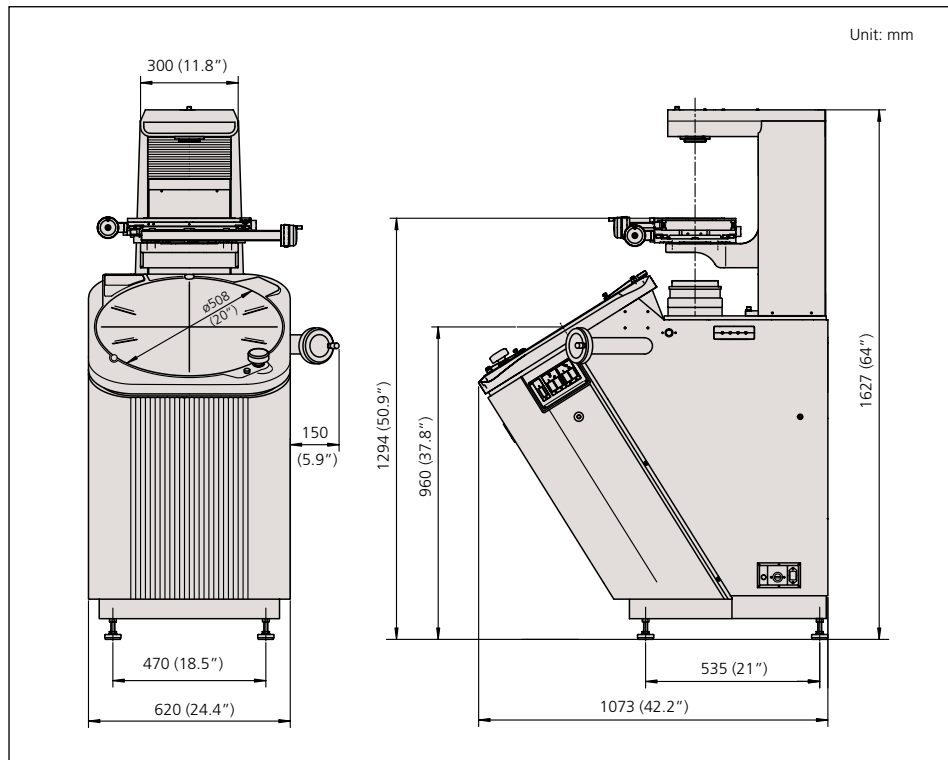

PH-A14

SERIES 172 — Profile Projector

FEATURES

- Benchtop model uses a horizontal optical system.
- Suitable for thread pitch measurements—blurred or distorted images will not be produced when workpiece is angled.
- Inverted image on the day-bright screen.
- 14" (356mm) diameter vernier protractor screen with solid line cross-hairs for easy alignment.
- Heavy-duty workpiece table incorporates linear scales for fast, accurate measurement.



Projection Capacity

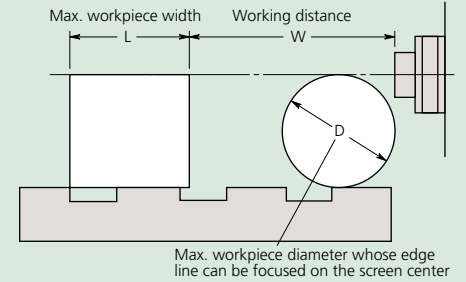

PH-A14

Unit: mm

	Magnification			
	10X	20X	50X	100X
View field	35.6	17.3	7.12	3.56
L	235	235	80	109
W	93	40	14.6	11
D	105	105	30.4	19

Optional Accessories

172-011:	10X projection lens (standard accessory)
172-012:	20X projection lens
172-013:	50X projection lens set
172-014:	100X projection lens set
172-116:	Standard scale (50mm)
172-117:	Standard scale (2")
172-118:	Reading scale (200mm)
172-161:	Reading scale (300mm)
172-119:	Reading scale (8")
172-162:	Reading scale (12")
172-286:	Green filter
512305:	Halogen bulb (24V, 150W) (standard accessory)

Fixture and Stage Accessories

172-142:	Center support
172-143:	Center support riser
172-144:	Rotary vise (Max. workpiece dia.: 2.4" / 60mm)
172-234:	V-block with clamp (Max. workpiece dia.: 2" / 50mm)
172-132:	Vertical holder
64AAA129B:	Machine stand 23"W x 45" D x 20"H



KA Counter (174-183A)
(Refer to page H-7 for more details.)
64AAB149: Counter stand



QM-Data200
2-D data processing unit.
264-155A: Stand mount type
264-156A: Arm mount type
(Refer to page I-23 for more details.)

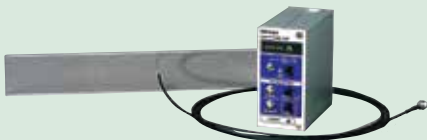

332-151: Optoeye
Edge detection system for QM-Data 200
12AAE671: Detector attachment (A)

SPECIFICATIONS

Model No.		PH-A14
Order No.		172-810-10A
Projected image		Inverted image
Protractor screen	Effective diameter	14" / 356mm
	Screen material	Fine ground glass
	Reference line	Cross hair line
	Screen rotation	±360°, fine feed and clamp
	Angle display	Vernier reading, Resolution: 2'
Projection lens		Standard accessory: 10X (172-011), Optional accessories: 20X, 50X, 100X
Magnification accuracy	Contour illumination	±0.1% or less
	Surface illumination	±0.15% or less
Contour illumination	Light source	Halogen bulb (24V 150W)
	Optical system	Telecentric system
	Functions	Heat-absorbing filter, Cooling fan
Surface illumination	Light source	Halogen bulb (24V 150W)
	Optical system	Twin fiber optic illumination
XY Stage	Table travel (X-axis)	8" / 203.2mm
	Table size (X, Z)	16 x 6" / 407 x 153mm
	Vertical travel (Y-axis)	4" / 101.6mm
	Resolution	.00005" / 0.001mm*
	Measuring unit	Built in Linear scale
	Max. workpiece width	See (L) on page I-12
Power supply		120V AC, 50/60Hz
Mass		308lbs / 140kg
Standard accessories		10x projection lens set, work stage, power cord, halogen bulb, fuse, grounding wire, allen wrench

*Counter not included

DIMENSIONS

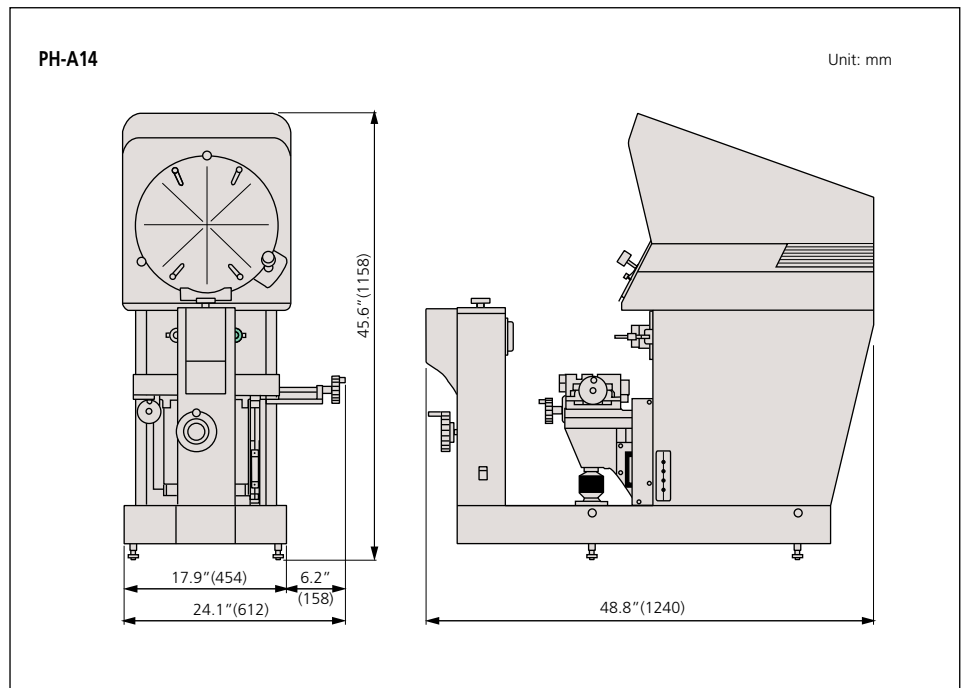

PH-3515F

SERIES 172 — Profile Projector

FEATURES

- Benchtop model uses a horizontal optical system.
- Suitable for thread pitch measurements—blurred or distorted images will not be produced when workpiece is angled.
- Erect image on the day-bright screen.
- Standard twin fiber-optic illumination.
- 14" (353mm) diameter protractor screen with cross-hairs and staggered lines for easy alignment.
- Digital angle measurement to 1' or 0.01°.
- Heavy-duty workpiece table incorporates linear scales for fast, accurate measurement.
- Built-in linear scales for use with optional display counters.



PH-3515F

Projection Capacity

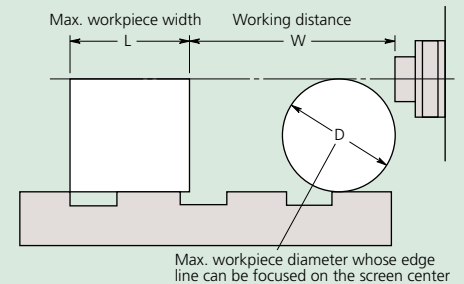

PH-3515F

Unit: mm

	Magnification				
	5X	10X	20X	50X	100X
View field	70.6	35.3	17.65	7.06	3.5
L	175	235	235	80	109
W	160 (64)	93 (35)	40	14.6	9.5
D	152.4	152.4	116	30.4	19

() : When using surface illumination

Optional Accessories

172-145:	5X projection lens set
172-175:	5X projection lens
172-184:	10X projection lens set (standard accessory)
172-011:	10X projection lens
172-173:	20X projection lens set
172-165:	50X projection lens set
172-174:	50X projection lens
172-166:	100X projection lens set
172-116:	Standard scale (50mm)
172-117:	Standard scale (2")
172-118:	Reading scale (200mm)
172-161:	Reading scale (300mm)
172-119:	Reading scale (8")
172-162:	Reading scale (12")
172-286:	Green filter
512305:	Halogen bulb (24V, 150W) (standard accessory)
172-423:	Twin surface illumination
12BAA653	Fiber optical illumination cable (standard accessory)
12BAA637	Halogen reflector lamp (standard accessory)
64AAB176	Machine stand
383228:	Vinyl cover (standard accessory)

Fixture and Stage Accessories*

172-142:	Center support
172-143:	Center support riser
172-144:	Rotary vise (Max. workpiece dia.: 2.3" / 60mm)
172-234:	V-block with clamp (Max. workpiece dia.: 2" / 50mm)
172-132:	Vertical holder
172-001:	Tipped-saw support stand
172-002:	Cutter support stand

* See page I-13 for details



KA Counter (174-183A)

(Refer to page H-7 for more details.)

64AAB149: Counter stand



QM-Data200

2-D data processing unit.

264-155A: Stand mount type

264-156A: Arm mount type

(Refer to page I-23 for more details.)

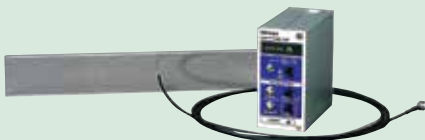

332-151: Optoeye

Edge detection system for QM-Data200

12AAE671: Detector attachment (A)

SPECIFICATIONS

Model No.	PH-3515F	
Order No.	172-868A	
Projected image	Erect image	
Protractor screen	Effective diameter	14" / 353mm
	Screen material	Fine ground glass
	Reference line	Cross hair line
	Screen rotation	±360°, fine feed and clamp
	Angle display (LED)	Resolution: 1' or 0.01° (switchable), Range: ±370°, Functions: Absolute/incremental mode switching, Zero set
Projection lens	Standard accessory: 10X (172-184), Optional accessories: 5X, 20X, 50X, 100X	
Magnification accuracy	Contour illumination	±0.1% or less
	Surface illumination	±0.15% or less
Contour illumination	Light source	Halogen bulb (24V 150W)
	Optical system	Telecentric system
	Functions	2-step brightness switch, Heat-absorbing filter, Cooling fan
Surface illumination (Optional accessories) XY Stage	Light source	Halogen bulb (24V 150W)
	Functions	Adjustable condenser lens, Heat-absorbing filter, Cooling fan
	Table travel (X-axis)	10" / 254mm
	Table size (X, Z)	17.7" x 5.7" / 450 x 146mm
	Vertical travel (Y-axis)	6" / 152mm
	Resolution	0.001mm / 0.00005"*
	Measuring Unit	Built-in Linear scale
	Max. workpiece width	See (L) on page I-10
	Max. workpiece load	100lbs / 45kg
	Power supply	120V AC, 50/60Hz
Mass	333lbs / 150kg	
Standard accessories	10X projection lens set, work stage, power cord, halogen bulb, tube fuse, grounding wire, allen wrench, Vinyl cover	

* Counter not included

DIMENSIONS

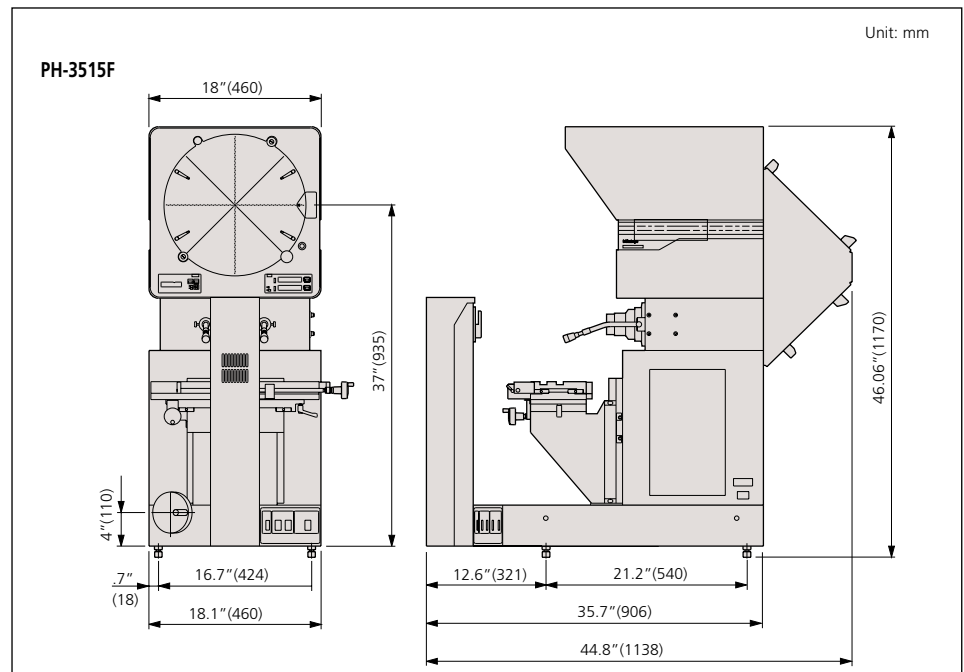

Accessories for Profile Projectors

SERIES 172 — Profile Projector

Standard Scales



172-116

- Used for checking magnification accuracy.

SPECIFICATIONS

Metric			
Graduation	Range	Order No.	Accuracy (20°C)*
0.1mm	50mm	172-116	(3+5L/1000)µm
0.1mm	80mm	172-330	(3+5L/1000)µm

*L = Measured length (mm)

Inch			
Graduation	Range	Order No.	Accuracy (20C)
.01"	2"	172-117	.00013"

Reading Scales

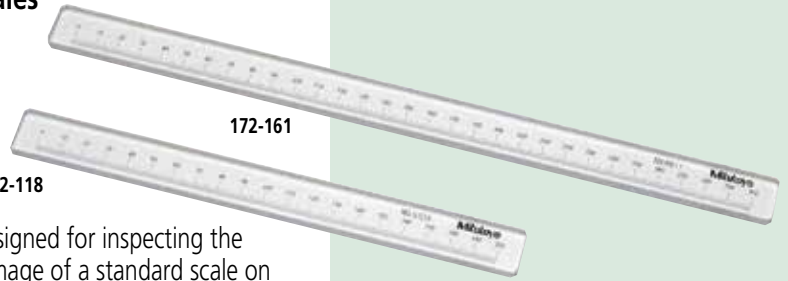

172-118

172-161

- Specially designed for inspecting the magnified image of a standard scale on the projection screen.

SPECIFICATIONS

Metric			
Graduation	Range	Order No.	Accuracy
0.5mm	200mm	172-118	18µm (15+15L/1000)µm
0.5mm	300mm	172-161	19.5µm (15+15L/1000)µm
0.5mm	600mm	172-329	24µm (15+15L/1000)µm

Inch			
Graduation	Range	Order No.	Accuracy
.02"	8"	172-119	.00071"
.02"	12"	172-162	.00077"

Micrometer Heads

for Profile Projectors and Toolmakers' Microscopes

Micrometer Heads for XY Stage

FEATURES

- Non-rotating device is provided.
- The thimble reading can be zero-set at any spindle position.
- Black and red figures of the bi-directional graduation allow easy reading in both directions.
- Clamping stem diameter: 18mm

SPECIFICATIONS

Metric				
Graduation	Range	Order No.	Accuracy	Remarks
0.005mm	25mm	152-390	±2µm	for X-axis
0.005mm	25mm	152-389	±2µm	for Y-axis

Inch				
Graduation	Range	Order No.	Accuracy	Remarks
.0001"	1"	152-391	±.0001"	for X-axis
.0001"	1"	152-392	±.0001"	for Y-axis

Adjustable Micrometer Heads for XY Stages

FEATURES

- The adjustable spindle can be fed under the thimble clamped at any reading, allowing easy reference point setting.
- The spherical measuring face is carbide-tipped.
- Clamping stem diameter: 18mm

SPECIFICATIONS

Metric				
Graduation	Range	Order No.	Accuracy	Remarks
0.001mm*	25mm	152-402	±2µm	for X-axis
0.001mm*	25mm	152-401	±2µm	for Y-axis

*Obtained using vernier.



152-390

Digimatic Micrometer Heads

FEATURES

- Large LCD digits for error-free reading.
- The display rotates 330° for easy viewing.
- The spindle does not rotate.
- With SPC data output.

SPECIFICATIONS

Inch/Metric			
Resolution	Range	Order No.	Accuracy
.00005"/0.001mm	2" (50mm)	164-164	±.00015"

Optional Accessories

- 959149: SPC cable for series 164 (1m)
- 959150: SPC cable for series 164 (2m)



164-164

Overlay Chart Set

- Makes inspection of projected images easy.
- Twelve patterns are available in the set.
- Designed for use with profile projectors whose screen diameter is 300mm or larger.

Overlay chart set (12 sheets) Order No.: 12AAM027

12AAM587

Protractor (1°-grad. radial index) and radius (1mm-radius increment concentric semicircles)

12AAM588

Radius (0.1cm-reading scales and 5mm-radius increment concentric circles)

12AAM589

Radius (1X, 10X, 20X, 50X)

12AAM590

1mm-reading scales (20X, 50X)

12AAM591

10x10mm sections

12AAM592

0.5mm-reading scales

12AAM593

1x1mm sections

12AAM594

Protractor (1°-grad. diametral index)

12AAM595

1mm-reading vertical scale

12AAM596

Protractor (1°-grad. diametral index) and radius (1mm-radius increment concentric circles)

12AAM597

Metric, Unified, and Whitworth screw threads (20X)

12AAM598

Metric screw thread (100X) and 20° and 14.5° gear teeth (20X)

Workpiece Fixtures

for Profile Projectors and Measuring Microscopes

Rotary Tables

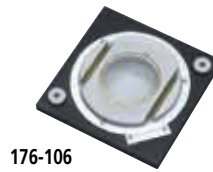

176-106

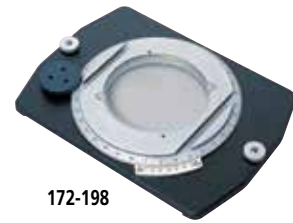

172-198

SPECIFICATIONS

Order No.	176-106	172-198
Effective glass dia.	66mm	100mm
Angle reading	6'	2' (w/ fine adjustment)
Mass	1.7kg	2.5kg

Note: Holder with clamp (176-107) can be mounted.

Holder with Clamp

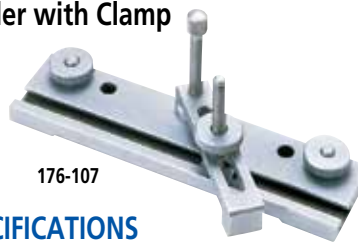

176-107

SPECIFICATIONS

Order No.	176-107
Max. workpiece height	35mm
Mass	0.42kg

Center Support



172-142

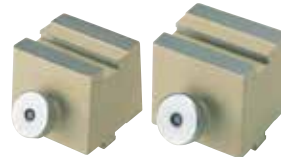

172-143

SPECIFICATIONS

Order No.	172-142
Max. workpiece height	120mm (240mm)*
Mass	3.3kg

*When using a center support riser (172-143)

Rotary Vise



172-144

SPECIFICATIONS

Order No.	172-144
Max. workpiece height	60mm
Width of jaw	40mm
Angle reading	5°
Mass	2.5kg

Swivel Center Supports



176-105



172-197

SPECIFICATIONS

Order No.	176-105	172-197
Max. workpiece dia.	70mm (45mm)*	80mm (65mm)*
Max. workpiece length	140mm	140mm
Swivel range	±10°	±10°
Mass	2.4kg	2.5kg

*When swiveled 10°

V-Block with Clamp



172-234



172-378

SPECIFICATIONS

Order No.	172-234	172-378
Max. workpiece dia.	50mm	25mm
Width of block	60mm	41mm
Mass	1.24kg	0.8kg

Vertical Holder

172-132



SPECIFICATIONS

Order No.	172-132
Mass	1.3kg

TM-505B/1005B

SERIES 176 — Toolmakers' Microscopes

The Mitutoyo TM Series is a toolmakers' microscope well suited for measuring dimensions and angles of machined metals. It also can be used to check the shape of screws and gears by attaching an optional reticle. The compact body makes it ideal for use on shop floors with limited space.

FEATURES

- Angle measurement is performed easily by turning the angle scale disc to align the cross-hair reticle with the workpiece image.

- Illumination intensity can be adjusted.
- Included standard accessories create an overall magnification of 30X. Magnifications can be changed from 20 - 200X by using optional objectives and/or eyepieces.



SPECIFICATIONS

Model No.	TM-505B	TM-A505B	TM-1005B	TM-A1005B
Order No.	176-818A	176-820A	176-819A	176-821A
Objective lens	Standard accessory: 2X, Options: 5X, 10X			
Microscope head	Maximum height of workpiece	4.53" / 115mm	4.21" / 107mm	
Illumination unit	Transmitted illumination	Stepless brightness adjustment, White LED light source, With green filter		
	Surface illumination	Oblique single-source type, Stepless brightness adjustment, White LED light source		
Cross-travel stage	Measuring range	2" x 2" / 50x50mm	4" x 2" / 100x50mm (An optional 2" / 50mm gauge block is required to cover full range. A CERA block is recommended.)	
	Table size	16" x 6" / 52x152mm	9.44" x 6" / 240x152mm	
	Usable area of the stage glass	3.8" x 3.8" / 96x96mm	6" x 3.8" / 154x96mm	
Linear measurement method	Micrometer heads optional	Micrometer heads included	Micrometer heads optional	Micrometer heads included
Resolution	N/A	.00005"/1μm	N/A	.00005"/1μm
Micrometer head travel range	N/A	2"/50mm	N/A	2"/50mm

DIMENSIONS

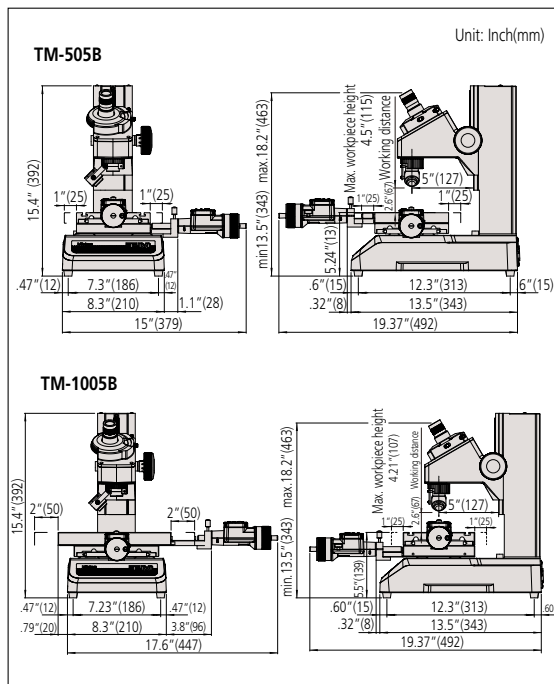

Technical Data

Optical tube	<ul style="list-style-type: none"> • Monocular with 30° depression angle • 90° broken cross-hair reticle (176-126) • Erect image • Diopter adjustable
Eyepiece protractor	<ul style="list-style-type: none"> • Graduation: 1° • Protractor range: 360° • Minimum reading by vernier: 6'
Eyepiece (176-116)	<ul style="list-style-type: none"> • Magnification: 15X • Field number: 13
Objective (176-138)	<ul style="list-style-type: none"> • Magnification: 2X • Working distance: 2.638" (67mm) • Numerical aperture: 0.07
Total magnification	• 30X
Transmitted illumination	<ul style="list-style-type: none"> • 3W LED • GIF (green) filter • Stepless intensity adjustment
Reflected illumination	<ul style="list-style-type: none"> • 3W LED • Stepless intensity adjustment • Adjustable position
Power supply	120 V AC, 50/60Hz
Power consumption	100VA
Mass	TM-505B: Approx. 30.8 lbs. (14kg) TM-1005B: Approx. 33 lbs. (15kg)

Optional Accessories

- 176-115: 10X eyepiece (view field dia.: 13mm)
- 176-116: 15X projection lens set (standard accessory)
- 176-117: 20X eyepiece (view field dia.: 10mm)
- 176-138: Objective, 2X (W.D. 67mm, N.A. 0.07) (standard accessory)
- 176-139: Objective, 5X (W.D.: 33mm, N.A.: 0.10)
- 176-137: Objective, 10X (W.D.: 14mm, N.A.: 0.14)
- 164-163: Digimatic micrometer head (range: 50mm, reading: 0.001mm)
- 164-164: Digimatic micrometer head (range: 2"/50mm, reading: .00005"/0.001mm)
- 152-390: Micrometer head for X-axis (range: 25mm, reading: 0.005mm)
- 152-389: Micrometer head for Y-axis (range: 25mm, reading: 0.005mm)
- 152-392: Micrometer head for Y-axis (range: 1", reading: .0001")
- 152-391: Micrometer head for X-axis (range: 1", reading: .0001")
- 611201-531: Rectangular gauge block (1")
- 611202-531: Rectangular gauge block (2")
- 176-204: Dial indicator attachment for Z-axis measurement
- 959149: SPC cable (2m) for Digimatic micrometer head
- 64PM1237: C-mount eyetube adapter

Fixture and Stage Accessories

- 990561: Workpiece clip (2pcs/set)
- 176-106: Rotary table for TM-505 (effective dia.: 66mm)
- 172-196: Rotary table for TM-510 (effective dia.: 100mm)
- 176-105: Swivel center support for TM-505 (max. workpiece dia.: 2.7" / 70mm)
- 172-197: Swivel center support for TM-510 (max. workpiece dia.: 3.1" / 80mm)
- 172-378: V-block with clamp (max. workpiece dia.: 1" / 25mm)
- 176-107: Holder with clamp

Illumination Units

- 176-344A: Bifurcated fiber illuminator
- 64AAB214: LED variable ring light
- 176-208A: LED circular illumination

Reticles

- 176-126: Broken cross-hair (90°) (standard accessory)
- 176-111: Concentric circles (up to ø4mm, 0.05mm increment)
- 176-135: Concentric circle (up to ø.2", .01" increment)
- 176-114: 60° angle
- 176-109: Metric screw threads (pitch = 0.25 - 1mm)
- 176-110: Metric screw threads (pitch = 1.25 - 2mm)
- 176-140: ISO metric screw threads (pitch = 0.075 - 0.7mm)
- 176-141: ISO metric screw threads (pitch = 0.75 - 2mm)
- 176-123: Unified screw threads (80 - 28TPI)
- 176-124: Unified screw threads (24 - 14TPI)
- 176-125: Unified screw threads (13 - 10TPI)
- 176-120: Whitworth screw threads (60 - 26TPI)
- 176-112: 20° involute gear teeth (normal rack type)

Protractor eyepiece



LED ring light 64AAB214



MF

SERIES 176 — Measuring Microscopes

Technical Data

Optical tube	<ul style="list-style-type: none"> • Monocular or Binocular (Must Choose) • 25° depression angle • 90° broken cross-hair reticle (12AAG836) • Erect image • TV Mount 50/50
Observation image	• Erect Image
Observation type	• Bright Field
Eyepiece lens	<ul style="list-style-type: none"> • 10x (Included w/Tube) • 15x (Optional) • 20x (Optional)
Objective	<ul style="list-style-type: none"> • Magnification: 3X (Included) • W.D.: 3.03" (77mm); N.A.: .09 • Optional: 1x, 5x, 10x, 20x, 50x, 100x
Light source	<ul style="list-style-type: none"> • Halogen or LED (Must Choose) • Adjustable aperture diaphragms • Light intensity infinitely adjustable
Transmitted illumination	• Telecentric illumination
Reflected illumination	• Koehler illumination
Display Unit	
Number of axis	• 2 axes (MF-A Type) or 3 axes (MF-B Type)
Resolution	• 0.0001" / 0.00005" / 0.00001" (0.001 mm / 0.0005 mm / 0.0001 mm)
Functions	• Data output, Axis linear compensation, Metric or English Units, and more
Stage	<ul style="list-style-type: none"> • Precision travel (2.2+0.02L)µm accuracy • High-accuracy linear glass scales • Quick-release floating mode • Zero-set button
Power consumption	45W LED, 160W Halogen, 120V AC, 50/60 Hz
Mass	<ul style="list-style-type: none"> • 1010D - 148 lbs. / 67 kg • 2010D - 157 lbs. / 71 kg • 2017D - 326 lbs. / 148 kg • 3017D - 344 lbs. / 156 kg • 4020D - 357 lbs. / 162 kg

LED and Halogen Light Options for Transmitted and Reflected Illumination

(Common to MF D and MF-U D) New design



Transmitted LED illumination unit (Common to MF/MF-U Series) Reflected LED illumination unit (for MF Series) Reflected LED illumination unit (for MF-U Series)



LED illumination Halogen illumination

High Visibility Digital Display

(Common to MF D and MF-U D)



Front of display Rear of display

The MF measuring microscopes can be combined with Mitutoyo's vision unit to boost its performance and data management on a PC, further improving measuring efficiency and productivity.

FEATURES

- Observation with a crisp and high-resolution erect image and a wide field of view
- Measuring accuracy that is highest in its class (and conforms to JIS B 7153)
- ML series, high-NA objectives that are specially designed for the MF series (long working distance type)
- Illumination unit (reflected/transmitted) selectable from a high-intensity LED or halogen bulb (selection required)
- Variable aperture diaphragm (reflected/transmitted) allows observation measurement while suppressing light diffraction
- Variety of standardized stages in sizes up to 400x200mm
- Quick-release mechanism useful for moving the stage quickly when measuring workpieces that are large in size or quantity
- Coarse/fine feed handles equipped as standard on both sides allow precise focus and observation measurement regardless of handedness
- High-magnification eyepiece observation up to 2000x
- Standard measuring microscope has a wide variety of optional accessories including a vision unit and various digital CCD cameras



MF-B2017D
XY stage travel range: 8 x 6.6" / 200 x 170mm (with optional binocular tube)



Using optional slide-type nosepiece with 2-lens mount (factory set option)

Selection of XY stage by travel range

1010D: 4 x 4" / 100 x 100mm



2010D: 8 x 4" / 200 x 100mm



2017D: 8 x 6.7" / 200 x 170mm



3017D: 12 x 6.6" / 300 x 170mm



4020D: 16 x 8" / 400 x 200mm



MF

SERIES 176 — Measuring Microscopes

SPECIFICATIONS

Model No. (XY stage size)	1010D	2010D	2017D	3017D	4020D	
Order No.	MF-A	176-861-10	176-862-10	176-863-10	176-864-10	176-865-10
	MF-B	176-866-10	176-867-10	176-868-10	176-869-10	176-870-10
XY stage travel range	4 x 4" 100 x 100mm	8 x 4" 200 x 100mm	8 x 7" 200 x 170mm	12 x 7" 300 x 170mm	16 x 8" 400 x 200mm	
Z-axis travel range	6" / 150mm		8.7" / 220mm			
Focusing method	Manual focusing (Coarse focusing: 30mm/rev., Fine focusing: 0.2mm/rev.)					
Measurement method	Linear encoder (2-axis model: X / Y-axis, 3-axis model: X / Y / Z-axis)					
Resolution (switchable)	.0001" / .00005" / .00001" (0.001mm / 0.0005mm / 0.0001mm)					
Measuring accuracy (at 20°C)	XY-axis: (2.2+0.02L) μ m, L = Measuring length (mm) when not loaded, JIS B 7153					
Indication accuracy (at 20°C)	Z-axis: (5+0.04L) μ m, L = Measuring length (mm), (MF-B type)					
Floating function	X and Y axes with Quick-release mechanism					
XY stage top size	11 x 11" 280 x 280mm	14 x 11" 350 x 280mm	16.1 x 13.4" 410 x 342mm	20.07 x 13.4" 510 x 342mm	24" x 13.4" 610 x 342mm	
Effective glass size	7 x 7" 180 x 180mm	10 x 6" 250 x 150mm	10.6 x 9.4" 270 x 240mm	14.5 x 9.4" 370 x 240mm	17.3 x 9.4" 440 x 240mm	
Swivel function	—		$\pm 5^\circ$ (left)		$\pm 3^\circ$ (left)	
Max. stage loading	22lbs / 10kg		44lbs / 20kg		33lbs / 15kg	
Max. workpiece height	6" / 150mm		8.7" / 220mm			

MF Selection of Machine Type

	1010	2010	2017	3017	4020	Counter	Motorized stage	Optics
A	176-861-10	176-862-10	176-863-10	176-864-10	176-865-10	X, Y	Manual	BF
B	176-866-10	176-867-10	176-868-10	176-869-10	176-870-10	X, Y, Z	Manual	BF
G	-	-	176-781A	176-782A	176-783A	X, Y, Z	X, Y, Z	BF
J	-	-	176-891A	176-892A	176-893A	X, Y, Z	Z only	BF

Example: MF-A1010D results in part number 176-861-10

Illumination Unit (must select)

Applicable Illumination Unit	LED	Halogen
Order No.	176-445A	176-447A

Eye Tube Selection (must select)

Monocular with 10X eyepiece	176-392
Binocular with 10X eyepiece	176-393

DIMENSIONS

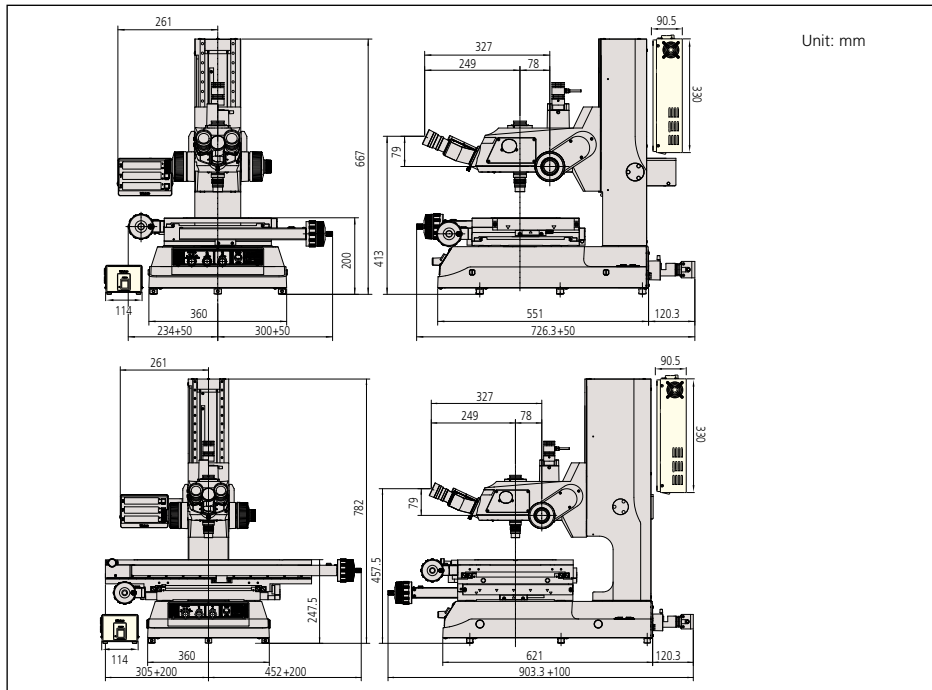

Optional Accessories

- 176-392:** Monocular tube with 10X eyepiece
- 176-393:** Binocular tube with 10X eyepiece set
- 378-866:** 10X eyepiece set (view field dia.: 24mm)
- 378-857:** 15X eyepiece set (view field dia.: 16mm)
- 378-858:** 20X eyepiece set (view field dia.: 12mm)
- 375-043:** Protractor eyepiece (10X)
- 176-313:** Digital protractor eyepiece (10X)
- 375-036-2:** 1X objective (W.D.: 61mm, N.A.: 0.03)
- 375-037-1:** 3X objective (W.D.: 77mm, N.A.: 0.09) (std. accessory)
- 375-034-1:** 5X objective (W.D.: 61mm, N.A.: 0.13)
- 375-039:** 10X objective (W.D.: 51mm, N.A.: 0.21)
- 375-051:** 20X objective (W.D.: 20mm, N.A.: 0.42)
- 375-052:** 50X objective (W.D.: 13mm, N.A.: 0.55)
- 375-053:** 100X objective (W.D.: 6mm, N.A.: 0.7)
- 176-370-1:** Slide-type nosepiece (2-mount, parfocal)
- 176-370-2:** Slide-type nosepiece (2-mount, mag. adjusted)
- 12AAA643:** ND2 color filter (transmitted / surface)
- 12AAA644:** ND8 color filter (transmitted / surface)
- 12AAA645:** GIF filter (transmitted / surface) (std. accessory)
- 12AAA646:** LB80 color filter (transmitted / surface)
- 375-054:** 0.5X camera adapter (with C-mount adapter)
- 970441:** C-mount adapter
- 513667:** Halogen bulb (12V, 50W)
- 12BAB345:** Halogen bulb (long life type, 12V, 50W)
- 176-308:** Vibration damping stand
- 176-309:** Mounting stand
- 375-056:** Stage micrometer
- 12AAA165:** Lens cleaning kit
- 12AAA846:** Foot switch
- 382951:** Vinyl cover (standard accessory) 2010 or less
- 12BAM841:** Vinyl cover 2017 or greater

Illumination Units

- 176-367-2A:** LED ring illuminator
- 176-343A:** Twin fiber-optics illuminator
- 176-366A:** Ring fiber-optics illuminator
- 12AAG806:** GIF color filter (for fiber-optics illuminator)
- 12AAG807:** LB80 color filter (for fiber-optics illuminator)

Fixture and Stage Accessories

- 176-107:** Holder with clamp
- 172-378:** V-block with clamp (max. workpiece dia.: 1" / 25mm)
- 172-197:** Swivel center support¹ (max. workpiece dia.: 3.1" / 80mm)
- 176-305:** Rotary stage with fine feed knob for 1010D/2010D models
- 176-306:** Rotary stage with fine feed knob for 2017D/3017D/4020D models

¹ Fixture mount adapter (**176-310**) is required for 2010D models. Fixture mount adapter (**176-304**) is required for 2017D/3017D/4020D models.



QM-Data200

- 2-D data processing unit
- 264-155A:** Stand-mount type
- 12AAA807:** Connecting cable set

Focus pilot FP-05

Focus assisting system



Vision Unit

PC-based vision measuring system
359-763

MF Motorized

SERIES 176 — Motorized Type Measuring Microscopes

- Motorized model of the MF Series. The X-, Y- and Z-axes are motorized, and the stage can be operated using a remote box.
- Using the optional vision unit enables the image AF function.
- Illumination unit (reflected/transmitted) can be selected from a high-intensity LED or halogen bulb (selection required).
- Variable aperture diaphragm (reflected/transmitted) allows observation measurement while suppressing light diffraction.
- A wide variety of optional accessories are offered.
- ML series, high-NA objectives that are specially designed for the MF series (long-working distance type).
- High-magnification observation up to 2000X.



MF-G2017D

• The binocular tube (eyepiece) and illumination unit are optional accessories.

SPECIFICATIONS

Model No.	MF-G2017D	MF-G3017D	MF-G4020D	
Order No.	176-781A	176-782A	176-783A	
Observation image	BF (Bright field)/Erect image			
Eyepiece	10X (field number: 24), 15X, 20X Note: Monocular unit: a 10X eyepiece (standard accessory), Binocular tube: two 10X eyepieces (standard accessory)			
Objective lens	ML series 3X objective lens (standard accessory), 1X, 5X, 10X, 20X, 50X, 100X			
Illumination unit (One of the two options must be selected.)	LED illumination unit	Transmitted illumination: Telecentric system, Built-in aperture diaphragm, White LED light source, stepless light intensity control, with cooling fan Reflected illumination: Koehler illumination, Variable aperture diaphragm mechanism, White LED light source, stepless light intensity control Control unit: Power ON/OFF switch (main switch), 100 - 240V AC power input connector		
	Halogen illumination unit	Transmitted illumination: Telecentric system, Built-in aperture diaphragm, Halogen bulb (12V, 50W), stepless light intensity control, with cooling fan Reflected illumination: Koehler illumination, Variable aperture diaphragm mechanism, Halogen bulb (12V, 50W), stepless light intensity control, with cooling fan Control unit: Power ON/OFF switch (main switch), 100 - 240V AC power input connector		
Vision AF ^{*1}	Available Option			
XY-axis Vision	Measuring range	200×170mm	300×170mm	400×200mm
Z-axis	Measuring range	220mm		
Measuring accuracy ^{*2}	(When no load is put on the X- or Y-axis)	(2.2+0.02L) μm L: Measuring length (mm)		
Digital counter	Resolution	1/0.5/0.1μm .0001"/.00005"/.00001" switchable		

*1: Vision Unit **359-763** and an image AF cable **12AAN358** are sold separately.

*2: Measuring method complies with JIS B7153.

Bulb replacement for transmitted/reflected illumination Standard: Halogen bulb (12V, 50W) (No.513667)
Bulb life: 1,100 hours

MF-U

SERIES 176 — High-power Multi-function Measuring Microscopes

FEATURES

- Observation with a clear and flareless erect image and a wide field of view
- Measuring accuracy that is highest in its class (and conforms to JIS B 7153)
- Proven high-NA objectives from the FS optical system (long-working distance type)
- Integration of metallurgical and measurement microscope functions provides high-resolution observation and high-accuracy measurement solution
- Illumination unit (reflected/transmitted) selectable from a high-intensity LED or halogen bulb (required)
- Variable aperture diaphragm (reflected/transmitted) allows for contrast adjustment
- Variety of standardized stages in sizes up to 400 x 200 mm
- Quick-release mechanism useful for moving the stage quickly when measuring workpieces that are large in size or quantity
- High-magnification eyepiece observation up to 4000X



MF-UB3017D
XY stage travel range: 12 x 6.7" / 300 x 170mm
(with optional turret, objective and fiber illumination)

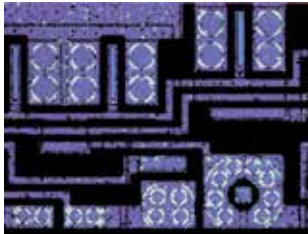

Polarized light observation:
Observing only the filtered light that vibrates in one direction. Used for observing materials with special optical characteristics, such as mineral and liquid crystal.



Dark field (DF) observation:
Observing only the scattered light by shutting down the direct light to the objectives. The scratches and dust that cannot be viewed in the bright view field can be observed by this method in high-contrast.



Differential interference contrast (DIC) observation:
Effective in detecting fine scratches and steps on the surface of metal, liquid crystal, and semiconductors.

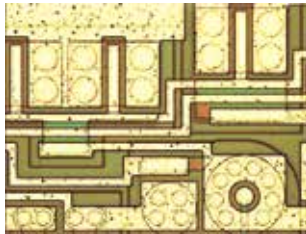

Bright field (BF) observation:
Most common method of observation. Observing directly the light reflected from the surface of the workpiece.

Technical Data

Observation image:	Erect image
Optical tube:	Siedentoph type (pupil distance adjustment: 51 - 76mm), 1X tube lens, Binocular tube (depression: 30°), Reticle projection method, with TV mount, Optical path ratio (eyepiece/TV mount: 50/50)
Eyepiece lens:	10X (field No.: 24mm), Optional: 15X, 20X
Turret (optional):	Manual or power
Objective (optional):	M / BD Plan Apo objective from 1X to 200X
Transmitted illumination	
• Light source:	Halogen bulb (12V, 50W) or LED
• Optical system:	Telecentric illumination with adjustable aperture diaphragms
• Functions:	Light intensity adjustable, Non-stepped brightness adjustment
Surface illumination	
• Light source:	Optional halogen illumination unit (fiber-optic cold light illumination) or LED
• Optical system:	Koehler illumination with adjustable aperture diaphragms
• Functions:	Light intensity adjustable, Non-stepped brightness adjustment
Display unit:	
• No. of axis:	2 axes or 3 axes
• Resolution:	.0001" / .00005" / .00001" / 0.001mm / 0.0005mm / 0.0001mm
• Functions:	Zero-setting, Direction switching, Data output (via RS-232C interface)
Power supply:	120V AC, 50/60Hz
Mass:	148lbs/67kg (1010D) / 157lbs/71kg (2010D) / 326lbs/148kg (2017D) / 344lbs/156kg (3017D) / 357lbs/162kg (4020D)

Selection of XY stage by travel range



1010D: 4 x 4" / 100 x 100mm



2010D: 8 x 4" / 200 x 100mm



2017D: 8 x 6.7" / 200 x 170mm



4020D: 16" x 8" / 400 x 200mm

Optional Accessories

- 378-866:** 10X eyepiece set (view field dia.: 24mm) (standard accessory)
- 378-857:** 15X eyepiece set (view field dia.: 16mm)
- 378-858:** 20X eyepiece set (view field dia.: 12mm)

Turret (Nosepiece) **must select**

- 378-018:** Adjustable manual BF turret (4 port)
- 378-216A:** Adjustable power BF turret (5 port)
- 176-211:** Adjustable manual BF/DF turret (4 port)
- 176-212A:** Adjustable power BF/DF turret (4 port)

Objectives
See page I-28 for objective selection

Manual and Power Turrets



- Filters
- 378-092:** Polarization unit
 - 378-076:** DIC unit for 100X, SL80X, SL50X objective
 - 378-078:** DIC unit for 50X, SL20X objective
 - 378-079:** DIC unit for 20X objective
 - 378-080:** DIC unit for 10X, 5X objective
 - 12AAA643:** ND2 color filter (for halogen illuminator, **176-448A**)
 - 12AAA644:** ND8 color filter (for halogen illuminator, **176-448A**)
 - 12AAA645:** GIF filter (standard accessory)
 - 12AAA646:** LB80 color filter (for halogen illuminator, (**176-448A**))

- Camera Mounts
- 375-054:** 0.5X camera adapter (with C-mount adapter)
 - 970441:** C-mount adapter
- See page I-33 for camera selection

- Bulbs
- 513667:** Halogen bulb (12V, 50W)
 - 12BAB345:** Halogen bulb (long life type, 12V, 50W)
 - 517181:** Halogen bulb (12V, 100W)
 - 12BAD602:** High intensity halogen bulb (12V, 100W)

- Illumination Units
- 176-315A:** Halogen illumination unit (12V, 100W)
 - 176-316A:** Halogen illumination unit (12V, 150W)
 - 176-343A:** Twin fiber-optics illuminator
 - 12AAG806:** GIF color filter (for **176-315A** and **176-343A**)
 - 12AAG807:** LB80 color filter (for **176-315A** and **176-343A**)

- Fixture and Stage Accessories
- 176-107:** Holder with clamp
 - 172-378:** V-block with clamp (max. workpiece dia.: 1" / 25mm)
 - 172-197:** Swivel center support* (max. workpiece dia.: 3.1" / 80mm)
 - 176-305:** Rotary stage with fine feed knob for 1010D/2010D models
 - 176-306:** Rotary stage with fine feed knob for 2017D/3017D models

*Fixture mount adapter (**176-310**) is required for 2010D models.
Fixture mount adapter (**176-304**) is required for 2017D/3017D/4020D models.

- Misc.
- 176-308:** Vibration damping stand
 - 176-309:** Mounting stand
 - 375-056:** Stage micrometer
 - 12AAA165:** Lens cleaning kit
 - 937179T:** Foot switch
- Reticle See page I-21

MF-U

SERIES 176 — High-Power Multi-Function Measuring Microscopes

SPECIFICATIONS

Model No. (XY stage size)	1010D	2010D	2017D	3017D	4020D
Order No.	MF-UA	176-871-10	176-872-10	176-873-10	176-874-10
	MF-UB	176-876-10	176-877-10	176-878-10	176-879-10
	MF-UC	176-881-10	176-882-10	176-883-10	176-884-10
	MF-UD	176-886-10	176-887-10	176-888-10	176-889-10
XY stage travel range	4 x 4" 100 x 100mm	8 x 4" 200 x 100mm	8 x 6.7" 200 x 170mm	12 x 6.7" 300 x 170mm	16 x 8" 400 x 200mm
Z-axis travel range	6" / 150mm			8.7" / 220mm	
Focusing method	Manual focusing (coarse focusing: 10mm/rev., fine focusing: 0.1mm/rev.)				
Measurement method	Linear encoder (2-axis model: X / Y-axis, 3-axis model: X / Y / Z-axis)				
Resolution (switchable)	.0001" / .00005" / .00001" (0.001mm / 0.0005mm / 0.0001mm)				
Measuring accuracy (at 20°C)	XY-axis: (2.2+0.02L)µm, L = Measuring length (mm) when not loaded, JIS B 7153				
Indication accuracy (at 20°C)	Z-axis: (5+0.04L)µm, L = Measuring length (mm)				
Floating function	X and Y axes with Quick-release mechanism				
XY stage top size	11 x 11" 280 x 280mm	14 x 11" 350 x 280mm	16 x 13.6" 410 x 342mm	20 x 13.6" 510 x 342mm	24 x 13.6" 610 x 342mm
Effective glass size	7.1 x 7.1" 180 x 180mm	10 x 6" 250 x 150mm	10.6 x 9.6" 270 x 240mm	14.6 x 9.6" 370 x 240mm	17.3 x 9.6" 440 x 240mm
Swivel function	—		±5° (left)		±3° (left)
Max. stage loading	22lbs / 10kg		44lbs / 20kg		33lbs / 15kg

Selection of machine type

Machine type	MF-UA	MF-UB	MF-UC	MF-UD
Observation type	Bright field (BF)	Bright field (BF)	Bright / Dark field (BF/DF)	Bright / Dark field (BF/DF)
Measurement system	X and Y-axis (2 axes)	X, Y and Z-axis (3 axes)	X and Y-axis (2 axes)	X, Y and Z-axis (3 axes)

Illumination Unit (**must select LED or Halogen illumination unit**)

Applicable Illumination Unit	LED	Halogen
Order No.	176-446A (transmitted & reflected)	176-448A (transmitted)
		176-316A (reflected)

Note: illumination unit not included. If halogen transmitted illumination is selected, then either 176-315A or 176-316A must be chosen.

DIMENSIONS

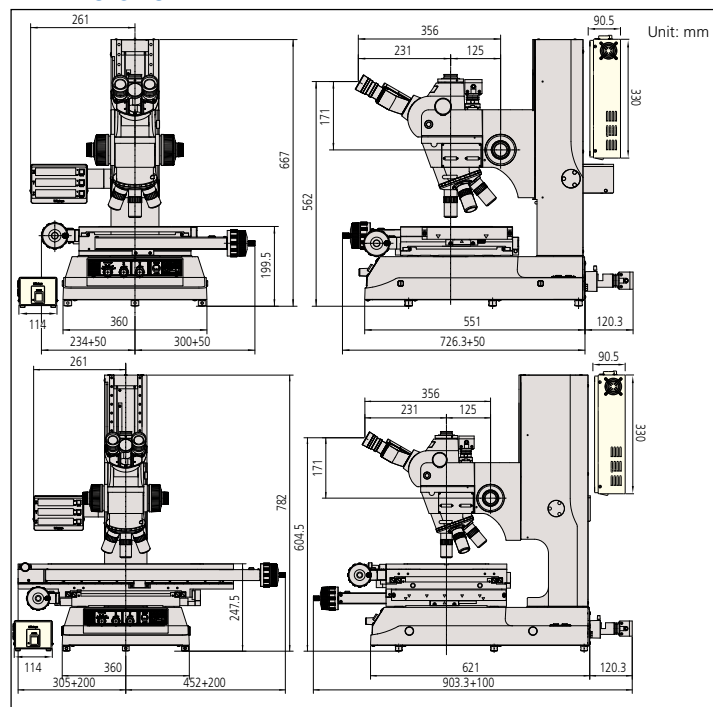

MF-U Motorized

SERIES 176 — Motorized-Type Universal Measuring Microscopes

- Motorized model of the MF-U Series. The X-, Y- and Z-axes are motorized, and the stage can be operated using a remote box.
- Using the optional vision unit enables the image AF function.
- Illumination unit (reflected/transmitted) can be selected from a high-intensity LED or halogen bulb (required).
- Variable aperture diaphragm (reflected/transmitted) allows observation measurement while suppressing light diffraction.
- A wide variety of optional accessories are offered.
- Proven high-NA objectives from the FS optical system (long working distance type).
- Integration of metallurgical and measurement microscope functions provide high-resolution observation and a high-accuracy measurement solution.
- High-magnification observation up to 4000X.
- MF-UE/UF is capable of performing Laser AF. The standard Laser AF function is equipped with the tracking function which maintains focus while the stage is in motion.



MF-UE2017D

• The turret, objectives and illumination unit are sold separately.

MF-U Selection of Machine Type

↓	2017	3017	4020	Counter	Motorized stage	Optics	LAF	Vision Unit
E	176-790A	176-791A	176-792A	X,Y,Z	X, Y, Z	BF	✓	✓
F	176-793A	176-794A	176-795A	X,Y,Z	X, Y, Z	BF/DF	✓	✓
G	176-784A	176-785A	176-786A	X,Y,Z	X, Y, Z	BF	-	✓
H	176-787A	176-788A	176-789A	X,Y,Z	X, Y, Z	BF/DF	-	✓
J	176-894A	176-895A	176-896A	X,Y,Z	Z only	BF	-	✓
K	176-897A	176-898A	176-899A	X,Y,Z	Z only	BF/DF	-	✓

Example: MF-UE2017D results in part number 176-790A

SPECIFICATIONS

BF (Bright field)	Model No.	MF-UG2017D	MF-UG3017D	MF-UG4020D	MF-UE2017D	MF-UE3017D	MF-UE4020D
	Order No.	176-784A	176-785A	176-786A	176-790A	176-791A	176-792A
BD (Bright / Dark field)	Model No.	MF-UH2017D	MF-UH3017D	MF-UH4020D	MF-UF2017D	MF-UF3017D	MF-UF4020D
	Order No.	176-787A	176-788A	176-789A	176-793A	176-794A	176-795A
Observation image	BF (Bright field), DF (Dark field) (MF-UC and MF-UD models only), Polarization, Differential Interference Contrast (DIC) / Erect image						
Eyepiece	Diopter adjustment	10X (standard accessory) (Field number: 24), 15X, 20X					
	BF (Bright field)	M Plan Apo, M Plan Apo HR, M Plan Apo SL, G Plan Apo					
Objective lens (optional)	BD (Bright / Dark field)	BD Plan Apo, D Plan Apo HR, BD plan Apo SL					
Illumination unit (One of the two options must be selected.)	LED illumination unit	Transmitted illumination: Telecentric system, Built-in aperture diaphragm, White LED light source, stepless light intensity control, with cooling fan Reflected illumination: Koehler illumination, Variable aperture diaphragm mechanism, White LED light source, Non-step light intensity control Control unit: Power ON/OFF switch (main switch), 100 - 240V AC power input connector					
	Halogen illumination unit	Transmitted illumination: Telecentric system, Built-in aperture diaphragm, Halogen bulb (12V, 50W), stepless light intensity control, with cooling fan Reflected: BF/BD Kohler illumination with adjustable aperture diaphragm, 12V100W or 12V15W halogen lamp (selectable), external fiber illumination, stepless brightness adjustment Control unit: Power ON/OFF switch (main switch), 100 - 240V AC power input connector					
Vision AF *1		✓			✓		
Laser AF *1		—			✓		
XY-axis	Measuring range	8x6.7" / 200x170mm	12x6.7" / 300x170mm	16x8" / 400x200mm	8x6.7" / 200x170mm	12x6.7" / 300x170mm	16x8" / 400x200mm
Z-axis	Measuring range	8.7" / 220mm					
Measuring accuracy	(When no load is put on the X- or Y-axis)	(2.2+0.02L) μm L: Measuring length (mm)					
Digital counter	Resolution	1/0.5/0.1μm .0001"/.00005"/.00001" switchable					

*1: Vision unit and an image AF cable are separately required.

*2: Measuring method complies with JIS B7153.

Bulb replacement for transmitted illumination Standard: Halogen bulb (12V, 50W) (No.513667), Bulb life: 1,100 hours
For replacement for reflected illumination (from separate light source) Standard: Halogen bulb (12V, 100W) (No.517181),
High-intensity bulb (12V, 100W) (No.12BAD602)
*At the time of purchase, a standard bulb and a high-intensity bulb are provided. (Only for the reflected illumination models.)

Accessories for Measuring Microscope

Stage Micrometer

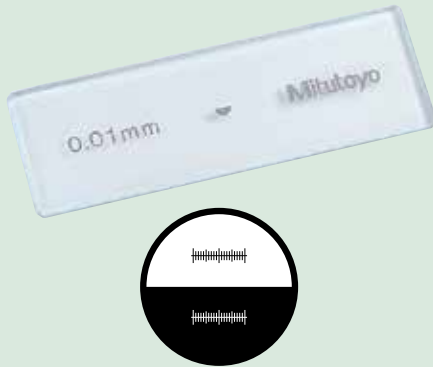

SPECIFICATIONS

Order No.	375-056
Range	1mm
Graduations	0.01mm
Accuracy (at 20°C)	(1+L)μm, L = Measuring length (mm)
Dimensions (WxD)	3" x 1" / 76 x 26mm
Mass	16g

Optional Reticles

- 12AAG838 (12AAG878): Cross-hair (7μm width)
- 12AAG836 (12AAG877)*: Cross-hair (5μm width)
- 12AAG873 (12AAG876): Cross-hair (3μm width)
- 12AAG839 (12AAG879): Cross-hair and 45° angle
- 12AAG840 (12AAG880): Broken cross-hair and 60° angle
- 12AAG841 (12AAG881): Zeiss type chart
- 12AAG842: 20mm scale (0.1mm reading)
- 12AAG843: Concentric circle (ø1.2 - ø18mm)
- 12AAG844: 10mm scale (0.1mm reading)
- 12AAG845: 5mm scale (0.05mm reading)
- 12AAG846: 10x10mm section (1mm min.)
- 12AAG847: Metric screw thread (P = 0.25-1.0)
- 12AAG848: Metric screw thread (P = 1.25-2.0)
- 12AAG849: Involute gear tooth (14.5°), module = 0.1 - 1.0
- 12AAG850: Involute gear tooth (20°), module = 0.1 - 1.0
- 12AAG851: Unified screw thread (80 - 28TPI)
- 12AAG852: Unified screw thread (24 - 14TPI)
- 12AAG853: Unified screw thread (13 - 10TPI)
- 12AAG854: Concentric circle (ø.01" - ø.2")

(): for MF-U models,
* Standard accessory

Reticle mount
(standard accessory)

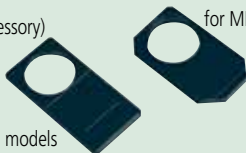

Cross-hair and 90° angle
(standard accessory)

Focus Pilot FP-05

FEATURES

- By installing this system on the camera mount of an MF series measuring microscope and projecting the focusing chart onto the workpiece surface, the focal point can be detected with high accuracy and high repeatability.
- The brightness of the chart can be adjusted.
- A wide view field observation on the monitor is made possible with the use of a CCD camera (C-mount adapter is included.)

- Four types of chart patterns are available. The pattern should be selected in accordance with the type of workpiece surface texture.



Concentric circle

Slit

SPECIFICATIONS

Order No.	375-057A	375-058A	375-067A	375-068A
Applicable microscopes	MF D models		MF-U D models	
Light source	Green LED	Red LED	Green LED	Red LED
Magnification	0.5X, Accuracy: 0.1%**			
Camera adapter	C-mount (provided)			
Applicable CCD camera	Up to 2/3-inch			
Mass	4lbs / 1.8kg			

** Within 2/3 area from the center of view field

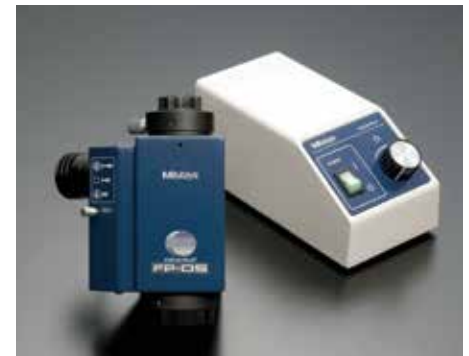

Manual and Power Turrets



SPECIFICATIONS

Order No.	176-211	378-018	176-212A	378-016A	378-216A
Observation type	BD	BF	BD	BF	BF
No. of objective mounts	4-mount	4-mount	4-mount	4-mount	5-mount
Driving method	Manual		Motor		
Dimensions (W x D x H)	—		Turret: 6.5 x 2.6 x 5.4"		
	—		164 x 65 x 137		
			Control Box: 4.1 x 3 x 7.6"		
			108 x 72 x 193		

Accessories for Measuring Microscope

Twin fiber-optics illuminator



SPECIFICATIONS

Order No.	176-343A
Applicable microscopes	MF, MF-U models
Length of fiber cable	28" / 700mm
Light source	Halogen bulb (12V, 100W) (517181: halogen bulb)
Dimensions (W x D x H)	Light unit: 9.3 x 3 x 4.7" 235 x 76 x 120mm

Ring fiber-optics illuminator

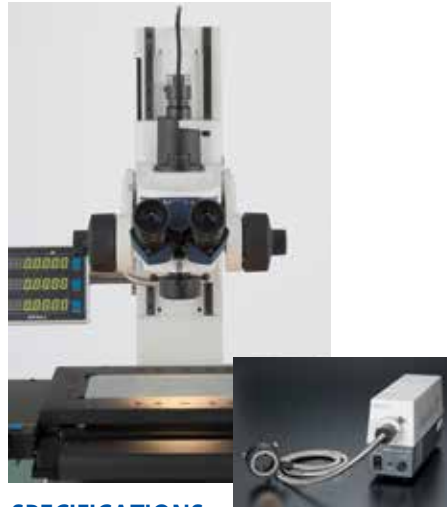

SPECIFICATIONS

Order No.	176-366A
Applicable microscopes	MF models (ML 10X or lower)
Length of fiber cable	40" x 1000mm
Light source	Halogen bulb (12V, 100W) (517181: halogen bulb)
Dimensions (W x D x H)	Light unit: 9.3 x 3 x 4.7" 235 x 76 x 120mm

LED Ring Illuminator

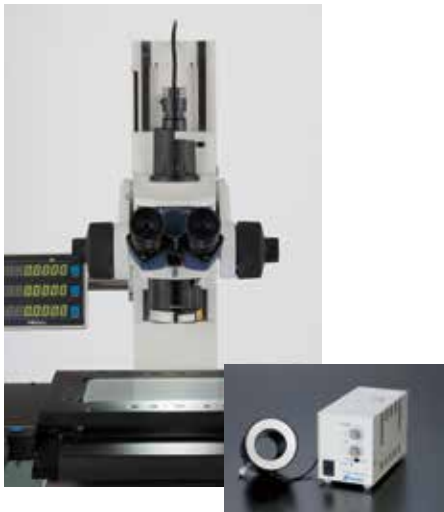

SPECIFICATIONS

Order No.	176-367-2A
Applicable microscopes	MF models with 1X/3X/5X/10X objective
Light source	White LED
Length of LED cable	59" / 1500mm

LED Ring Light (for sliding nosepiece)



SPECIFICATIONS

Order No.	176-371A
Applicable microscopes	MF models with 1X/3X/5X/10X objective
Light source	LED

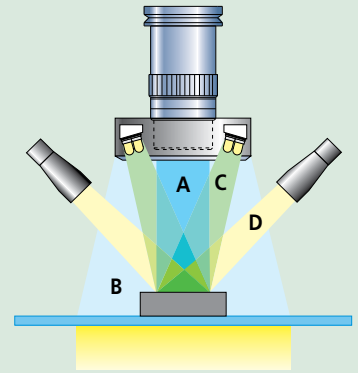

A: Vertical surface illumination (Halogen)

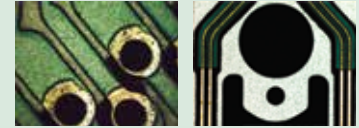

PCB

HDD suspension

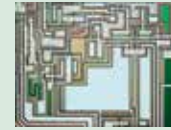

IC circuit

B: Ring fiber optics illumination

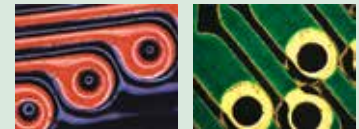

Flexible PCB

PCB



Electric parts

C: LED ring illumination



HDD suspension

PCB



Black resin molded parts

D: Twin fiber-optics illumination



IC package

Garnet



PCB

QM-Data200

SERIES 264 — 2-D Data Processing Unit

Technical Data

Resolution:	0.0001mm
Program functions:	Part program creation, execution, editing
Statistical processing:	Number of data, maximum value, minimum value, mean value, standard deviation, range, histogram
Element memory:	Maximum of 1000 elements
Element recall:	Point, line, circle, distance, ellipse, rectangular hole, slotted hole, intersection and intersecting angle
Element key-in:	Point, line, circle
Display system:	Monographic LCD (320 x 240 dots, with back light)
Measurement result file output:	RS-232C/USB output (CSV format, MUX-10F format)
Display language:	Japanese/English/German/French/Italian/Spanish/Portuguese/Swedish/Polish/Dutch/Hungarian
Data input:	RS-232C/USB, X/Y/Z-axis signal, Footswitch
Data output:	RS-232C/USB
Power supply:	120V AC, 50/60Hz
Mass:	2.2kg (stand-mount type) 2.1kg (arm-mount type)

QM-Data200

Order No.: 264-155A (stand-mount type)
Order No.: 264-156A (arm-mount type)

The QM-Data200 is a geometric readout/analysis unit for optical instruments like profile projectors. This features powerful 2-D coordinate measurement capabilities with unmatched simple key operation. The QM-Data200 improves operator productivity, minimizes errors, and saves measurement time and production cost.

FEATURES

- Various graphic displays on the large colored LCD screen for easy measurement operations.
- One-key operation for combined measurements that are often used (circle-circle distance, etc.)



QM-Data 200
Stand-mount type

- The AI measurement function (automatic identification of measuring item) eliminates switching between the measurement command keys.
- Equipped with the measurement procedure teaching function and the measuring position navigation in Repeat mode.
- The user menu function allows user to register measurement commands or part programs to create his own menu.
- Tolerance zone measurement of data processing result and various statistical processing for each item is available.
- Measurement result output to "MS-Excel" in spreadsheet (CSV) format.
- The measurement procedure and measurement result can be saved, using a USB drive.
- Two models available: a stand-alone type with tilt system and a flexible-arm type that can be mounted on a profile projector.

Intuitive panel design

The QM-Data200 employs Geometry Keys to accelerate the measurement process. The probing routine of standard geometric features and combinations are designed with Geometry Keys on the front panel. Click the key you need and capture features to complete the measurement quickly and accurately. This improves operator productivity, reduce errors, and saves operation time and cost.

Graphic display

Measurement information and data are visualized on the back-lit colored LCD with graphical interfaces. The geometric feature selected is displayed with the probing navigator. The measurements map and blink indication show the probing points and sequences. This improves operation accuracy and reduces errors and time.



QM-Data200

SERIES 264 — 2-D Data Processing Unit

SYSTEM DIAGRAM

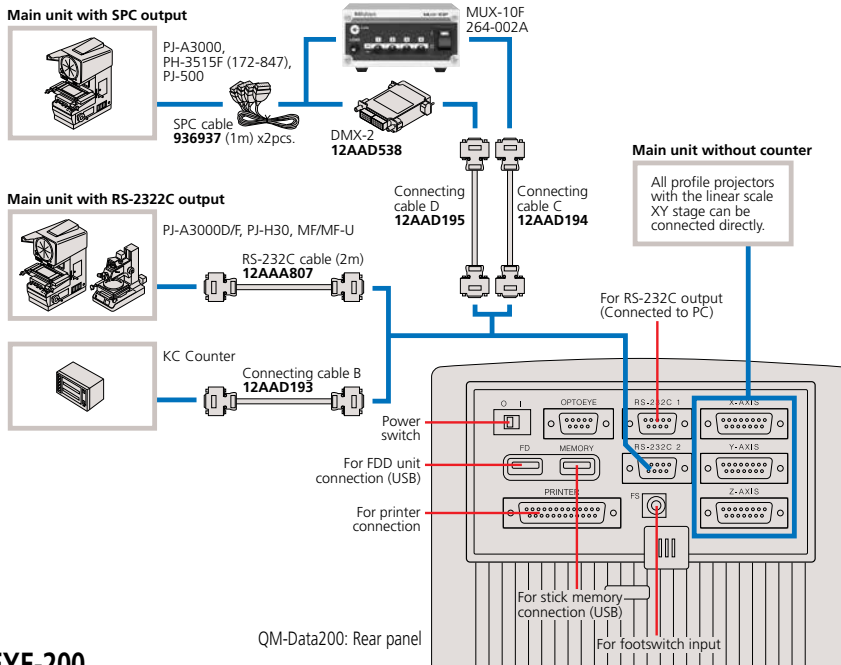

OPTOEYE-200

The OPTOEYE-200 Image Edge Sensor eliminates human errors, ensuring speedy, accurate and consistent measurements, regardless of operator's skill.

FEATURES

- OPTOEYE-200 adopts a thin fiber-optic cable for detector connection for easy set-up and smart operation without obstructing your view.

- Bright and dark buttons allow easy calibration.
- OPTOEYE can be powered by QM-Data200 via the connecting cable. No AC adapter is required.
- The brightness of the chart can be adjusted.



DIMENSIONS

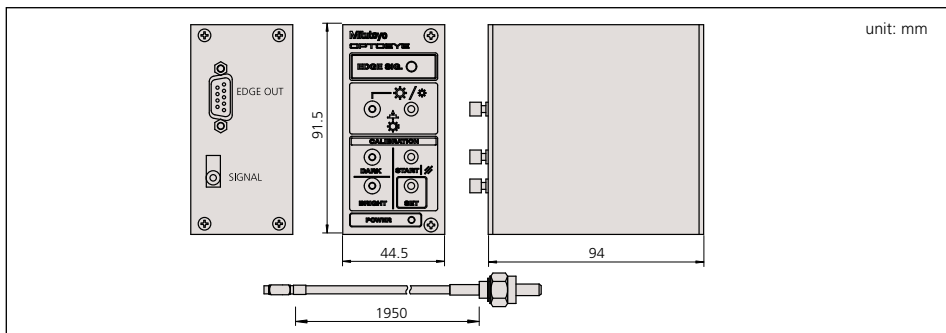

Optional Accessories

- 12AAD034: Receipt printer (for 120V)
- 223663: Printer paper for receipt printer
- 12AAA804: Printer cable (2m)
- 937179T: Foot switch
- 12AAD193: Connection cable B
- 12AAD194: Connection cable C
- 12AAD195: Connection cable D
- 12AAA807: RS-232C cable (2m)
- 12AAA808: RS-232C cable (4m)

Technical Data

- Image detection
 - Directivity: Non-direction
 - Min. diameter: $\varnothing 2\text{mm}$ on the screen
 - Min. width: 1mm on the screen
 - Max. moving speed: 1000mm/s
- Applicable illumination
 - Type: Surface / Contour illumination
 - Range: 30Lx to 1500Lx on the screen
- Repeatability: 1 μm in contour illumination
- Function: Error in detection of illumination change Supporting a contour illumination brightness selector switch of projector

Optional Accessories

- 12AAE671: Detector attachment (A)
 - PJ-A3000, PJ-H30, PH-3515, PH-A14 series (Adaptation diameter of a screen: 10" / $\varnothing 250$ to 14" / $\varnothing 350\text{mm}$)
- 12AAE672: Detector attachment (B)
 - PJ-500, PV-5110, PV-600A series (Adaptation diameter of a screen: 20" / $\varnothing 500$ to 24" / $\varnothing 600\text{mm}$)



Vision Unit

SERIES 359 — Vision System Retrofit for Microscopes

SPECIFICATIONS

Projected Image	Inverted Image
Onscreen Magnification	19x-1900x (22" Monitor)
Camera Unit	
Image Sensor Size	1/2" Color CMMOS
Image Sensor Resolution	3 MP
Interface	USB 2.0
Dimensions (WxDxH)	2.28 x 2.32 x 3.27" 58 x 59 x 83mm
Adapter Unit	
Measurement Software	QSPak VUE (optional)
Dimensions (DXH)	1.77 x 4.84" / 45 x 123mm
Magnification	0.5x
Optional Accessory:	Foot Switch (12AAJ088)

QSPAK, optional software

For observation/comparison of form

- Template matching function
- Manual pattern matching function

For simple measurement

- One-click edge detection tool function
- Smart tool function
- User macro function

For repeated measurement/ auto-measurement

- Quick navigation function
- Playback function
- Graphic function
- External data output function
- Statistical calculation function

One-click Edge Detection

By clicking the mouse near the edge of a workpiece, QSPAK automatically scans the edge and detects it, showing its coordinates. This function also works with the point tool, box tool, circle tool and auto-focus tool.



Graphic Window

The measurement results and measured elements are plotted in the graphic window in real-time. By using this function, the user can check the current measuring position at a glance. The graphic window can be used for geometrical calculation.

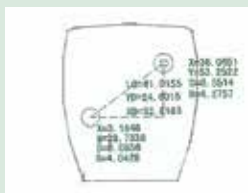

FEATURES

- The automatic edge-detection tools and various macro icons allow measurement in one easy step.
- The graphics and measurement navigation functions facilitate operation.
- Image data input/storage function.
- Measurement results are output in CVS format. This lets the user generate an inspection table in MS-Excel®.
- Allows the tolerance zone measurement of measurement results and various types of statistical processing for each item.
- Combined use with the focus pilot provides high-accuracy height measurements. (Patent pending)

- A series of measuring operations can be performed using just one screen display.
- The auto-brightness control function reproduces the type and degree of illumination required. (This function is limited to the MF/MF-U series.)

QSPAK Measurement Window

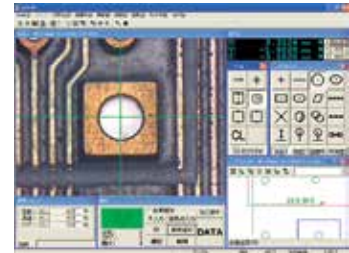

The PC system, QSPAK software and microscope are optional.

Vision Unit
No.: 359-763 (for MF D)

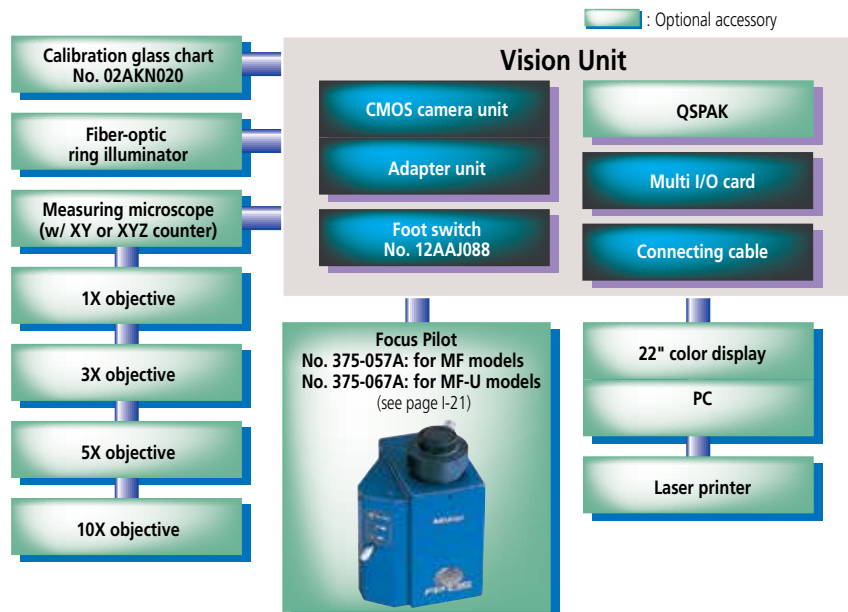

FS-70

SERIES 378 — Microscope Unit for Semiconductor Inspection

FEATURES

- The optical system that was developed for the best-selling FS 60 models was further enhanced for the FS70 models. It is ideal as a microscope unit of a prober station for semiconductors. (All models CE marked.)
- The FS70L supports three types of YAG laser wavelength ranges (1064nm, 532nm and 355nm), while the FS70L4 supports two types of wavelength ranges (532nm and 266nm), thus expanding a scope of laser applications, allowing laser-cutting of thin-films used in semiconductors and liquid crystal substrates. However, Mitutoyo assumes no responsibility for the performance and/or safety of the laser system used with Mitutoyo microscopes. Careful examination is recommended in selecting a laser-emission unit.
- Bright field, differential interference contrast (DIC) and polarized observations are optional with FS70Z and FS70. The FS70L and FS70L4 do not support the DIC method.
- By employing an inward revolver, the long working distance objectives provide excellent operability.
- An ergonomic design with superb operability: the FS70 employs the erect-image optical system (the image in the field of view has the same orientation as the specimen) and enlarged fine focus adjustment wheel with rubber-grip coarse adjustment knob.



Technical Data

Focus Adjustment Method:	With concentric coarse and fine focusing wheels (right and left)
Range:	50mm travel range 0.1mm/rev. for fine adjustment, 3.8mm/rev. for coarse adjustment
Trinocular tube Image:	Erect image
Pupil distance:	Siedentopf type, adjustment range: 2-3" / 51-76mm
Field number:	24
Tilt angle:	0° - 20° (only -TH, -THS models)
Illumination system:	Reflective illumination for bright field (Koehler illumination, with aperture diaphragm)
Light source (optional):	12V100W fiber optics, non-stepped adjustment, light guide length 1.5m, power consumption 150W
Objectives (optional):	M Plan Apo, M Plan Apo SL, G Plan Apo

SPECIFICATIONS

Model No. Order No.	FS70 378-184-1	FS70-TH 378-184-3	FS70Z 378-185-1	FS70Z-TH 378-185-3	FS70L 378-186-1	FS70L-TH 378-186-3	FS70L4 378-187-1	FS70L4-TH 378-187-3
Short base model No. Order No.	FS70-S 378-184-2	FS70-THS 378-184-4	FS70Z-S 378-185-2	FS70Z-THS 378-185-4	FS70L-S 378-186-2	FS70L-THS 378-186-4	FS70L4-S 378-187-2	FS70L4-THS 378-187-4
Focus adjustment	50mm travel range with concentric coarse (3.8mm/rev) and fine (0.1mm/rev) focusing wheels (right / left)							
Image	Erect image							
Pupil distance	Siedentopf type, adjustment range: 2 - 3" / 51 - 76mm							
Field number	24							
Tilt angle	—	0° - 20°	—	0° - 20°	—	0° - 20°	—	0° - 20°
Optical pass ratio	50/50	100/0 or 0/100	50/50	100/0 or 0/100	100/0 or 0/100	100/0 or 0/100	100/0 or 0/100	100/0 or 0/100
Protective filter	—		—		Built-in laser beam filter		Built-in laser beam filter	
Tube lens	1X		1X - 2X zoom		1X		1X	
Applicable laser	—		—		1064/532/355nm		532/266nm	
Camera mount	C-mount (using optional adapter B)				Use a laser with TV port.		C-mount receptacle (with green filter switch)	
Illumination system, optional	Reflective illumination for bright field (Koehler illumination, with aperture diaphragm) 12V 100W fiber optics, non-stepped adjustment, light guide length: 1.5m, power consumption 150W							
Objective, optional (for observation)	M Plan Apo, M Plan Apo SL, G Plan Apo							
Objective, optional (for laser-cutting)	—				M/LCD Plan NIR, M/LCD Plan NUV		M Plan UV	
Loading weight*	32lbs/14.5kg	30lbs/13.6kg	31lbs/14.1kg	29lbs/13.2kg	31lbs/14.2kg	30lbs/13.5kg	31lbs/13.9kg	29lbs/13.1kg
Mass (main unit)	13lbs/6.1kg	15.5lbs/7.1kg	14.5lbs/6.6kg	16.5lbs/7.5kg	14lbs/6.4kg	15.5lbs/7.2kg	14.5lbs/6.7kg	16.5lbs/7.5kg

*Loading weight on optical tube excluding weight of objective lenses and eyepieces.

Optional Accessories

For a complete listing of accessories see Microscope Units and Objectives brochure, E4191-378

VMU

SERIES 378 — Video Microscope Unit

The VMU is a compact, light-weight, and easy-to-install microscope unit for CCD camera monitoring in semiconductor fabrications.

FEATURES

- The rigidity and general performance of the VMU-LB & VMU-L4B have been enhanced compared to previous models.
- The optical system features ultra-long working distance objectives and correction for the wide range of radiation.
- The fiber-optic reflected illumination keeps the workpiece free from thermal expansion caused by heat. The fiber-optic illuminator is required for the light source.
- Also available with a laser mount or revolving nosepiece (objective mount).

SPECIFICATIONS

Magnification of tube	1X
Applicable wavelength	378-505, 378-506 378-507, 378-513 378-508 378-514
Objective	(Optional) see pg. I-28 thru I-32
Reflected illumination	• Telecentric system with aperture stop system. • Fiber-optic illuminator (optional) is required.
Light source	Halogen bulb (21V, 150W) (optional)
Mass	378-505: 570g 378-506: 590g 378-507: 980g 378-508: 1010g 378-513: 1300g 378-514: 1300g

Selection Guide of System Configuration

Order No. (Depends on each system configuration)	VMU-V 378-505	VMU-H 378-506	VMU-L 378-507	VMU-L4 378-508	VMU-LB 378-513	VMU-L4B 378-514
Vertical CCD camera mount	●					●
Horizontal CCD camera mount		●				
YAG laser mount			●	●	●	●
Fiber-optic illumination unit			▲	▲	▲	▲
M Plan Apo, M Plan Apo SL, G Plan Apo objectives for bright field observation	▲	▲	▲	▲	▲	▲
M Plan Apo NIR, LCD Plan Apo NIR, M Plan Apo NUV and LCD Plan Apo NUV objectives for laser cutting			▲		▲	▲
M Plan UV objectives for laser machining				▲		▲

●: Provided, ▲: Available as optional accessory

Wide VMU: FEATURES

- Offers approximately 7 times larger inspection area.
- Increases throughput by allowing for batch measurements.
- BD models can accommodate darkfield optics.

- 378-515** WIDE VMU-V
378-516 WIDE VMU-H
378-517 WIDE VMU-BDV
378-518 WIDE VMU-BDH



Technical Data

FOV in Camera Port	30mm Diameter
Camera Mount	F Mount (with C mount Adapter)
Example Sensor Size	APS-C format (2 inches)

Wide VMU Accessories

378-724	BF Revolver
378-725	BD Revolver
378-726	BF Motorized Revolver
378-727	BD Motorized Revolver

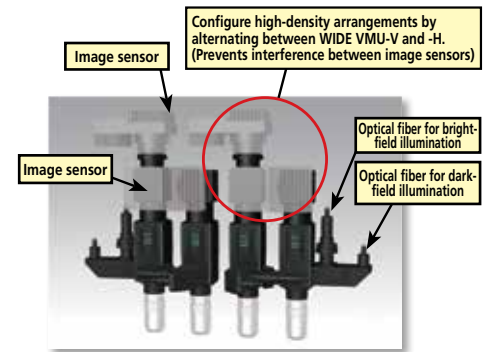
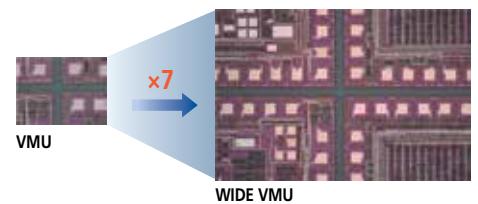

Eyepieces

SERIES 378

FEATURES

- The field of view is extra wide.
- Optional reticles are available.



378-866



378-857



378-858

SPECIFICATIONS

Order No. (2pcs. set)	Magnification	Field number	Mass	Individual order No.
378-866	10X	24	85g	378-856-5
378-857	15X	16	40g	378-857-5
378-858	20X	12	55g	

Reticles (optional)

- 516848: Cross-hair
- 516576: Broken cross hair (90° and 60°)
- 516578: Concentric circle (Diametric increment: 1.2mm)
- 516577: 20mm scale (Minimum reading: 0.1mm) with cross hair
- 516849: 10mm scale (Minimum reading: 0.1mm)
- 516850: 5mm scale (Minimum reading: 0.05mm)

Objectives

SERIES 378

The Mitutoyo 378 Series objectives have the world's longest working distance and an infinity correction optical system. These objectives provide flexible observation at high magnifications and independent correction of chromatic aberration.

FEATURES

- The long working distance objectives provide excellent clearance between the lens surface and the workpiece surface in focus, making it possible to observe workpieces which are usually hard-to-focus because of awkward projections.

- The metallurgical plan apochromatic (M Plan Apo) objective provides a flat, chromatic aberration-free image throughout the field of view, making it suitable for any type of microscope.
- Specially designed objectives also are available with correction for near-infrared radiation, near-ultraviolet radiation, and ultraviolet radiation, or various thicknesses of LCD screen glasses.
- The mounting screw threads of objectives are designed to conform to JIS B-7141-1988.



M Plan Apo and M Plan Apo SL objectives for bright field observation



BD Plan Apo and BD Plan Apo SL objectives for bright/dark field observation



Near-infrared radiation corrected M Plan Apo NIR objectives



Near-ultraviolet radiation corrected M Plan Apo NUV objectives



Ultraviolet radiation corrected M Plan UV objectives



M Plan Apo for Bright Field Observation

Order No.	Mag.	N.A.	W.D.	f	R	D.F.	View field 1	View field 2	Mass
378-800-3	1X	0.025	11.0mm	200mm	11.0μm	440μm	ø24mm	4.8x6.4mm	300g
378-801-6	2X	0.055	34.0mm	100mm	5.0μm	91μm	ø12mm	2.4x3.2mm	220g
378-802-6	5X	0.14	34.0mm	40mm	2.0μm	14.0μm	ø4.8mm	0.96x1.28mm	230g
378-807-3	7.5X	0.21	35.0mm	26.67mm	1.3μm	6.2μm	ø3.6mm	0.64x0.85mm	240g
378-803-3	10X	0.28	34.0mm	20mm	1.0μm	3.5μm	ø2.4mm	0.48x0.64mm	240g
378-804-3	20X	0.42	20.0mm	10mm	0.7μm	1.6μm	ø1.2mm	0.24x0.32mm	270g
378-805-3	50X	0.55	13.0mm	4mm	0.5μm	0.9μm	ø0.48mm	0.10x0.13mm	290g
378-806-3	100X	0.70	6.0mm	2mm	0.4μm	0.6μm	ø0.24mm	0.05x0.06mm	320g

DIMENSIONS

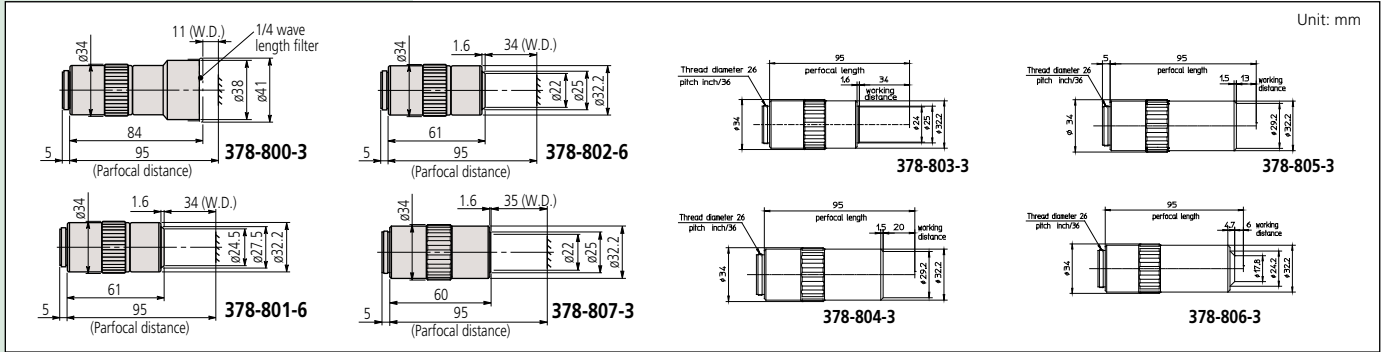

Note:
These objectives offer extra-long working distance.



M Plan Apo SL for Bright Field Observation

Order No.	Mag.	N.A.	W.D.	f	R	D.F.	View field 1	View field 2	Mass
378-810-3	20X	0.28	30.5mm	10mm	1.0μm	3.5μm	ø1.2mm	0.24x0.32mm	240g
378-811-3	50X	0.42	20.5mm	4mm	0.7μm	1.6μm	ø0.48mm	0.10x0.13mm	280g
378-812-3	80X	0.50	15.0mm	2.5mm	0.6μm	1.1μm	ø0.3mm	0.06x0.08mm	280g
378-813-3	100X	0.55	13.0mm	2mm	0.5μm	0.9μm	ø0.24mm	0.05x0.06mm	290g
378-816-3	200X	0.62	13.0mm	1mm	0.4μm	0.7μm	ø0.12mm	0.025x0.03mm	490g

DIMENSIONS

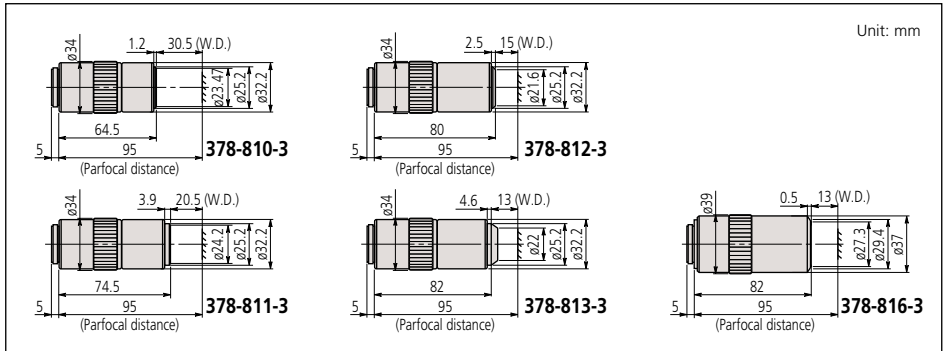

Note:
These objectives offer extra-high resolving power.

Mag.: Magnification
N.A.: Numerical aperture
W.D.: Working distance
f: Focal distance
R: Resolving power
D.F.: Focal depth
View field 1:
Field of view when using ø24mm eyepiece
View field 2:
Field of view when using 1/2" CCD camera

M Plan Apo HR for Bright Field Observation

Order No.	Mag.	N.A.	W.D.	f	R	D.F.	View field 1	View field 2	Mass
378-787-4	5X	0.21	25.5mm	40mm	1.3μm	6.2μm	ø4.8mm	0.96x1.28mm	285g
378-788-4	10X	0.42	15mm	20mm	0.7μm	1.6μm	ø2.4mm	0.48x0.64mm	460g
378-814-4	50X	0.75	5.2mm	4mm	0.4μm	0.49μm	ø0.48mm	0.10x0.13mm	400g
378-815-4	100X	0.90	1.3mm	2mm	0.3μm	0.34μm	ø0.24mm	0.05x0.06mm	410g

DIMENSIONS

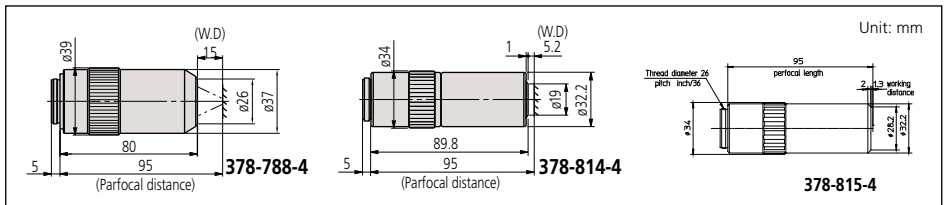

Glass Thickness (t = 3.5mm) Corrected G Plan Apo for Bright Field Observation

Order No.	Mag.	N.A.	W.D.	f	R	D.F.	View field 1	View field 2	Mass
378-847	20X	0.28	29.42mm*	10mm	1.0μm	3.5μm	ø1.2mm	0.24x0.32mm	270g
378-848-3	50X	0.50	13.89mm*	4mm	0.6μm	1.1μm	ø0.48mm	0.10x0.13mm	320g

*In air

DIMENSIONS

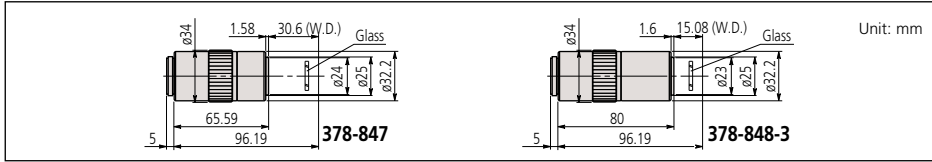

Note:
The G Plan Apo Series are designed for observing a workpiece through BK-7 glass (thickness = 3.5mm).

BD Plan Apo for Bright/Dark Field Observation

Order No.	Mag.	N.A.	W.D.	f	R	D.F.	View field 1	View field 2	Mass
378-831-7	2X	0.055	34.0mm	100mm	5.0μm	91μm	ø12mm	2.4x3.2mm	340g
378-832-7	5X	0.14	34.0mm	40mm	2.0μm	14.0μm	ø4.8mm	0.96x1.28mm	350g
378-830-7	7.5X	0.21	34.0mm	26.67mm	1.3μm	6.2μm	ø3.6mm	0.64x0.85mm	350g
378-833-7	10X	0.28	34.0mm	20mm	1.0μm	3.5μm	ø2.4mm	0.48x0.64mm	350g
378-834-7	20X	0.42	20.0mm	10mm	0.7μm	1.6μm	ø1.2mm	0.24x0.32mm	400g
378-835-7	50X	0.55	13.0mm	4mm	0.5μm	0.9μm	ø0.48mm	0.10x0.13mm	440g
378-836-7	100X	0.70	6.0mm	2mm	0.4μm	0.6μm	ø0.24mm	0.05x0.06mm	460g

DIMENSIONS

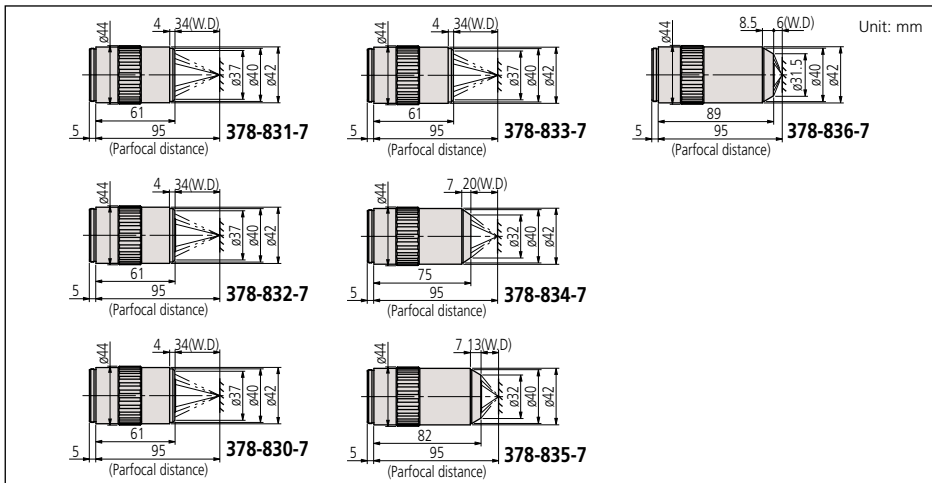

BD Plan Apo SL for Bright/Dark Field Observation

Order No.	Mag.	N.A.	W.D.	f	R	D.F.	View field 1	View field 2	Mass
378-840-7	20X	0.28	30.5mm	10mm	1.0μm	3.5μm	ø1.2mm	0.24x0.32mm	350g
378-841-7	50X	0.42	20.0mm	4mm	0.7μm	1.6μm	ø0.48mm	0.10x0.13mm	410g
378-842-7	80X	0.50	13.0mm	2.5mm	0.6μm	1.1μm	ø0.3mm	0.06x0.08mm	430g
378-843-7	100X	0.55	13.0mm	2mm	0.5μm	0.9μm	ø0.24mm	0.05x0.06mm	440g

DIMENSIONS

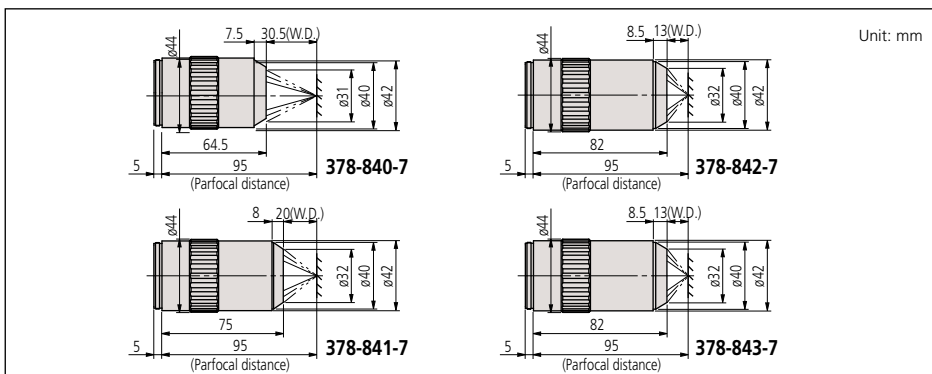

Note:
These objectives offer extra-long working distance.

Mag.: Magnification
N.A.: Numerical aperture
W.D.: Working distance
f: Focal distance
R: Resolving power
D.F.: Focal depth
View field 1: Field of view when using ø24mm eyepiece
View field 2: Field of view when using 1/2" CCD camera

Note:
These objectives offer extra-high resolving power.

BD Plan Apo HR for Bright/Dark Field Observation

Order No.	Mag.	N.A.	W.D.	f	R	D.F.	View field 1	View field 2	Mass
378-845-7	50X	0.75	5.2mm	4mm	0.4 μ m	0.49 μ m	\varnothing 0.48mm	0.10x0.13mm	530g
378-846-7	100X	0.90	1.3mm	2mm	0.3 μ m	0.34 μ m	\varnothing 0.24mm	0.05x0.06mm	545g

DIMENSIONS

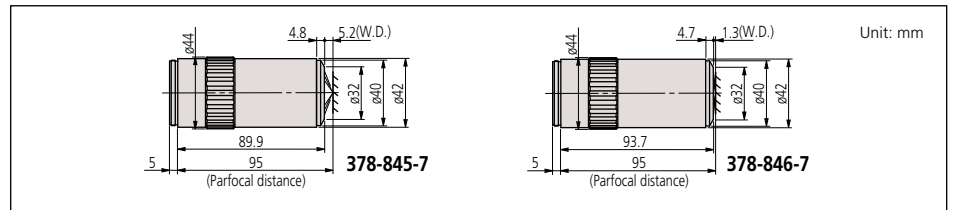

Near-infrared Radiation Corrected M Plan Apo NIR for Bright Field Observation

Order No.	Mag.	N.A.	W.D.	f	R	D.F.	View field 1	View field 2	Mass
378-822-5	5X	0.14	37.5mm	40mm	2.0 μ m	14.0 μ m	\varnothing 4.8mm	0.96x1.28mm	220g
378-823-5	10X	0.26	30.5mm	20mm	1.1 μ m	4.1 μ m	\varnothing 2.4mm	0.48x0.64mm	250g
378-824-5	20X	0.40	20.0mm	10mm	0.7 μ m	1.7 μ m	\varnothing 1.2mm	0.24x0.32mm	300g
378-825-5	50X	0.42	17.0mm	4mm	0.7 μ m	1.6 μ m	\varnothing 0.48mm	0.10x0.13mm	315g
378-826-5	100X	0.50	12.0mm	2mm	0.6 μ m	1.1 μ m	\varnothing 0.24mm	0.05x0.06mm	335g
378-863-5*	50X	0.65	10mm	4mm	0.4 μ m	0.7 μ m	\varnothing 0.48mm	0.10x0.13mm	450g
378-864-5*	100X	0.70	10mm	2mm	0.4 μ m	0.6 μ m	\varnothing 0.24mm	0.05x0.06mm	450g

* High Resolution (HR objectives)

DIMENSIONS

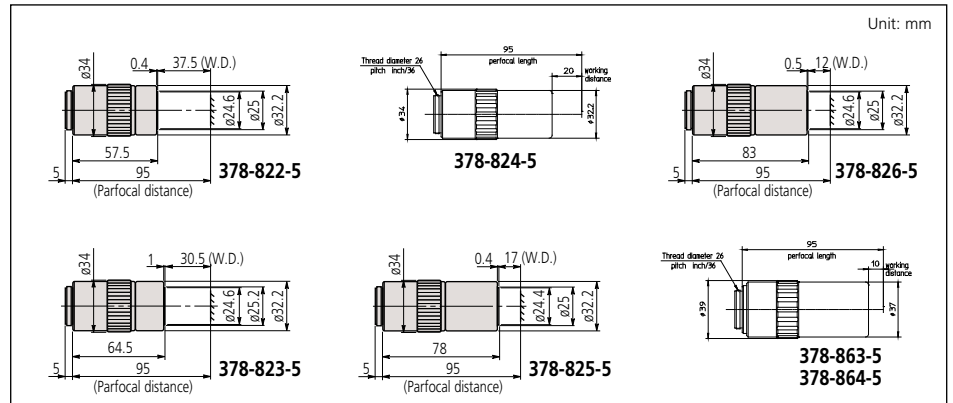

Near-ultraviolet Radiation Corrected M Plan Apo NUV for Bright Field Observation

Order No.	Mag.	N.A.	W.D.	f	R	D.F.	View field 1	View field 2	Mass
378-809-5	10X	0.28	30.5mm	20mm	1 μ m	3.5 μ m	\varnothing 2.4mm	0.48x0.64mm	255g
378-817-6	20X	0.40	17.0mm	10mm	0.7 μ m	1.7 μ m	\varnothing 1.2mm	0.24x0.32mm	340g
378-818-4	50X	0.42	15.0mm	4mm	0.7 μ m	1.6 μ m	\varnothing 0.48mm	0.10x0.13mm	350g
378-819-4	100X	0.50	11.0mm	2mm	0.6 μ m	1.1 μ m	\varnothing 0.24mm	0.05x0.06mm	380g
378-888-6*	50X	0.65	10.00mm	4mm	0.42 μ m	0.65 μ m	\varnothing 0.48mm	0.10x0.13mm	500g

*High resolution (HR objective)

DIMENSIONS

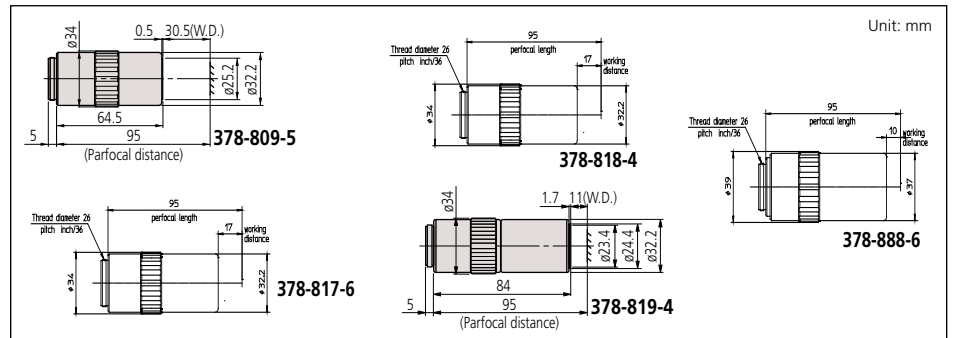

Note:
These objectives are designed so that a workpiece's image can be focused within the focal depth even when the wavelength is changed anywhere from the visible range ($\lambda = 480\text{nm}$) up to near-infrared range ($\lambda = 1800\text{nm}$). Therefore, the M Plan NIR Series are suitable for laser repair. However, when the wavelength used exceeds 1100nm, the focusing position may slightly deviate from that in the visible range due to changes in glass dispersion and refractive index.



Note:
These objectives are designed so that a workpiece's image can be focused within the focal depth even when the wavelength is changed anywhere from the visible range ($\lambda = 620\text{nm}$) to the near-ultraviolet range ($\lambda = 355\text{nm}$). Therefore the M Plan NUV Series are suitable for laser repair using a high frequency laser beam.

- Mag.: Magnification
- N.A.: Numerical aperture
- W.D.: Working distance
- f: Focal distance
- R: Resolving power
- D.F.: Focal depth

View field 1: Field of view when using \varnothing 24mm eyepiece
View field 2: Field of view when using 1/2" CCD camera

Near-Infrared Radiation and LCD Glass Thickness (t = 1.1mm or 0.7mm) Corrected LCD Plan Apo NIR for Bright Field Observation

Order No.	Mag.	N.A.	W.D.	f	R	D.F.	View field 1	View field 2	Mass
378-827-5	20X (t1.1)	0.40	19.98mm*	10mm	0.7μm	1.7μm	ø1.2mm	0.24x0.32mm	305g
378-828-5	50X (t1.1)	0.42	17.13mm*	3.9mm	0.7μm	1.6μm	ø0.48mm	0.10x0.13mm	320g
378-829-5	50X (t0.7)	0.42	17.26mm*	3.9mm	0.7μm	1.6μm	ø0.48mm	0.10x0.13mm	320g
378-752-5	100X (t1.1)	0.50	12.13mm*	2mm	0.6μm	1.1μm	ø0.24mm	0.05x0.06mm	335g
378-754-5	100X (t0.7)	0.50	11.76mm*	2mm	0.6μm	1.1μm	ø0.24mm	0.05x0.06mm	335g

*In air



Note:

These near-infrared (λ = 1800nm) corrected objectives are designed for observing a workpiece through LCD glass (thickness = 1.1mm (378-827-5, 378-828-5, 378-752-5) or 0.7mm (378-829-5, 378-754-5) and for laser repair.

DIMENSIONS

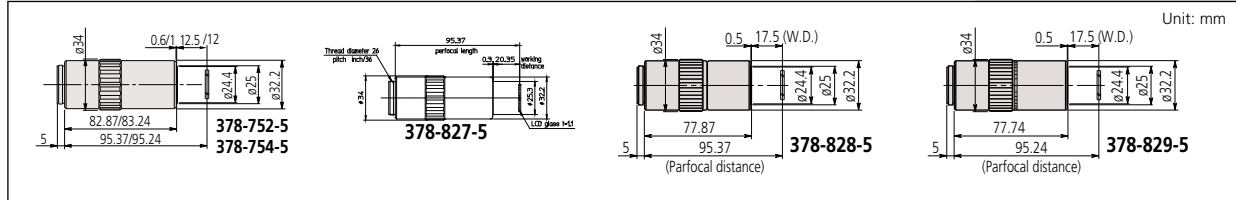

Near-ultraviolet Radiation and LCD Glass Thickness (t = 0.7mm) Corrected LCD Plan Apo NUV for Bright Field Observation

Order No.	Mag.	N.A.	W.D.	f	R	D.F.	View field 1	View field 2	Mass
378-890-6	20X (t0.7)	0.4	16.96mm*	10mm	0.7μm	1.7μm	ø1.2mm	0.24x0.32mm	340g
378-891-6**	50X (t0.7)	0.65	9.76mm*	4mm	0.42μm	0.65μm	ø0.48mm	0.10x0.13mm	500g
378-820-6	50X (t0.7)	0.42	14.76mm*	4mm	0.7μm	1.6μm	ø0.48mm	0.10x0.13mm	310g
378-753-6	50X (t1.1)	0.42	14.53mm	4mm	0.7μm	1.6μm	ø0.48mm	0.10x0.13mm	310g
378-751-4	100X (t1.1)	0.50	11.03mm	2mm	0.6μm	1.1μm	ø0.24mm	0.05x0.06mm	380g

* In air

** High-Resolution (HR Objectives)



Note:

These near ultraviolet corrected objectives are designed for observing a workpiece through LCD glass (thickness = 1.1mm (378-753-6, 378-751-4) or 0.7mm (378-820-6) and for laser repair.

DIMENSIONS

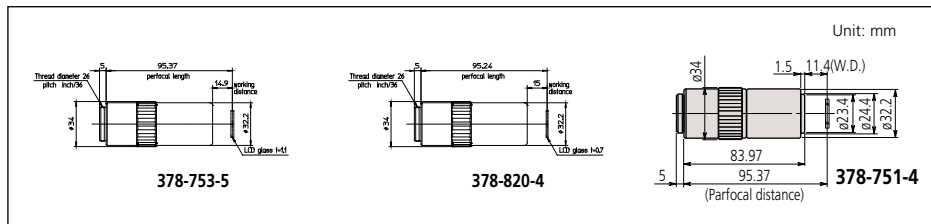

Ultraviolet Radiation Corrected M Plan UV for Bright Field Observation

Order No.	Mag.	N.A.	W.D.	f	R	D.F.	View field 1	View field 2	Mass
378-844-15	10X	0.25	20mm	20mm	1.1μm	4.4μm	ø2.4mm	0.48x0.64mm	310g
378-837-7	20X	0.36	15.0mm	10mm	0.8μm	2.1μm	ø1.2mm	0.24x0.32mm	330g
378-838-8	50X	0.41	12.0mm	4mm	0.7μm	1.7μm	ø0.48mm	0.10x0.13mm	400g
378-839-5	80X	0.55	10.0mm	2.5mm	0.5μm	0.9μm	ø0.3mm	0.06x0.08mm	380g

DIMENSIONS

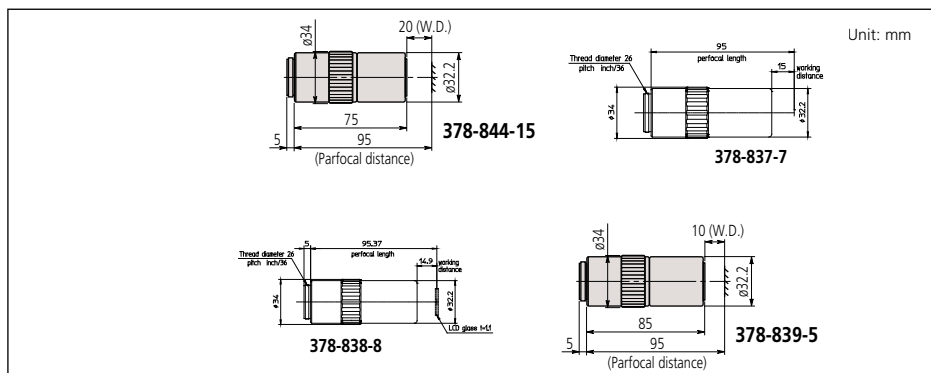

Note:

These ultraviolet corrected objectives are designed so that a workpiece's image can be focused within the focal depth even when the wavelength is changed anywhere from the visible range (λ = 550nm) to the ultraviolet range (λ = 266nm). Therefore the M Plan UV Series are suitable for laser repair using a high-frequency laser beam.

Mag.: Magnification
N.A.: Numerical aperture
W.D.: Working distance
f: Focal distance
R: Resolving power
D.F.: Focal depth

View field 1: Field of view when using ø24mm eyepiece
View field 2: Field of view when using 1/2" CCD camera

MSM-400

SERIES 377 — Stereo Microscopes

FEATURES

- Continuous 1X - 4X magnification
- Image always in focus throughout zoom range
- Crisp, erect images with high resolution and excellent stereoscopic effect
- Stereo-tube can be rotated a full 360°, for viewing at any angle
- Bilateral zoom control knob adds convenience and increases operator efficiency
- Diopter adjustment for both eyepieces

- Binocular tube inclination: 45°
- Focusing range: 1.46" (37mm)
- Interpupillary adjustable range: 2.12" - 2.99" (54mm - 76mm)
- Optional zoom ranges from 2.5X - 10X to 30X - 120X

The MSM-414L is a traditional binocular stereo microscope for industrial, medical and classroom applications. It is ideal for electrical small part inspection, assembly, and medical/biological dissection.

Optional Accessories

Illuminated Stand

Order No.	Description
377-412	Pole-Type Stand (top: 12V/10W flat filament tungsten, bottom: 5W fluorescent)
377-413*	Pole-Type Stand (top: 12V/10W flat filament tungsten, bottom: 12V/10W halogen with intensity control)
377-414	Fixed-Arm Stand (top: 12V/10W flat filament tungsten, bottom: 5W fluorescent)
377-415	Fixed-Arm Stand (top: 12V/10W flat filament tungsten, bottom: 12V/10W halogen with intensity control)
377-416	Fixed-Arm Stand (top: 5W fluorescent, bottom: 5W fluorescent)

*Standard Accessory



Digital Imaging with Software

Order No.	Description
64AAB429	MOTICAM 2, 2.0 MEGAPIXEL-1/3" CMOS, USB
64AAB529	MOTICAM 3+, 3.0 MEGAPIXEL-1/2" CMOS, USB
64AAB431	MOTICAM 5, 5.0 MEGAPIXEL-1/2.5" CMOS, USB
64AAB526	MOTICAM 1080, 2.0 MEGAPIXEL-1/2.8" CMOS, USB/HDMI



Optional Accessories

Order No.	Description
64AAB214	LED Variable Ring Light
64PMI237	MOTICAM EYETUBE ADAPTOR (for TM Scopes)

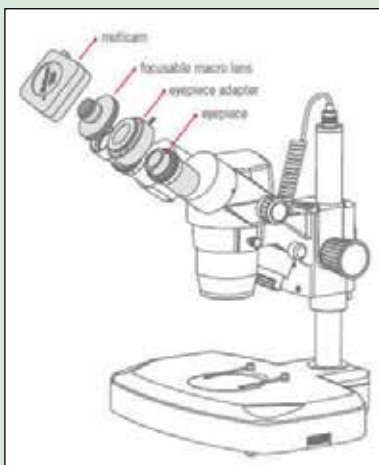

Motic Images Plus 2.0 - Measurements

SPECIFICATIONS

Model.	MSM-414L	MSM-414TL
Order No.	377-972A	377-974A
Optical tube	Binocular	Trinocular
Total magnification	10X - 40X	
Eyepiece	10X (377-016)	
Objective	1X - 4X	
Working distance	80mm	
Field of view	20mm - 5mm	
Dimensions	H=13.2" x W=6.7" x D=9.3"	
Mass	13.2 lbs (6kg)	

Stereo Microscopes

SERIES 377

377-972A/377-974A SYSTEM DIAGRAM

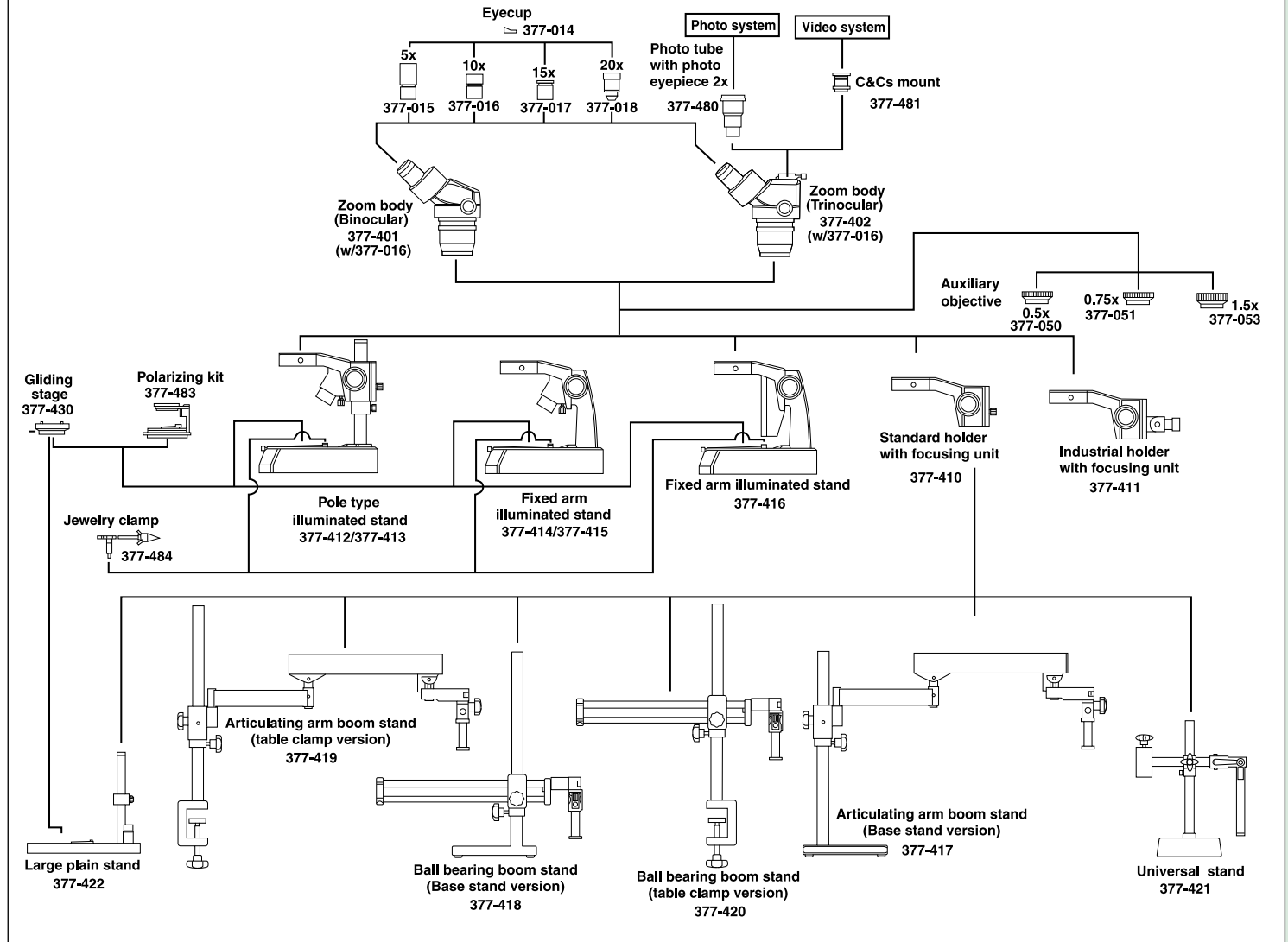

MSM-400

SERIES 377 — Stereo Microscopes

FEATURES

- Superior quality optics provide high-resolution
- Crystal sharp, high-color contrast image with excellent depth of field
- Always in sharp focus at all magnifications
- The Parfocal Optical System allows relaxed strain-free viewing
- Long working distance
- Extreme large field of view (23mm diameter)

The MSM-465L, Order No. 377-990A, is a high-accuracy four-step magnification stereo microscope. With a horizontal

changer allowing 6X, 12X, 25X, and 50X magnifications with a standard 1X objective and 10X eyepieces, the MSM-465L has limitless capabilities for electrical small part inspection.

The MSM-464L, Order No. 377-991A, with its vertical five-step magnification changer is ideal for small part assembly. This stereo microscope with standard 6.4X, 10X, 16X, 25X, and 40X magnifications, has flexibility from 3.2X to 160X magnifications.

Optional Accessories

Video System

Order No.	Description
377-488	Video System* for 377-990A
377-489	Video System* for 377-991A

* Converts Binocular to Trinocular

Accessories

Order No.	Description
64AAB214	LED variable ring light



MSM-465L
377-990A



MSM-464L
377-991A

Digital Imaging with Software

Order No.	Description
64AAB429	MOTICAM 2, 2.0 MEGAPIXEL-1/3" CMOS, USB
64AAB529	MOTICAM 3+, 3.0 MEGAPIXEL-1/2" CMOS, USB
64AAB431	MOTICAM 5, 5.0 MEGAPIXEL-1/2.5" CMOS, USB
64AAB526	MOTICAM 1080, 2.0 MEGAPIXEL-1/2.8" CMOS, USB/HDMI

SPECIFICATIONS

Model. Order No.	MSM-465L 377-990A	MSM-464TL 377-991A
Optical tube	Binocular*	Binocular*
Total magnification	6X - 50X	6.4X - 40X
Eyepiece	10X (377-456)	10X (377-456)
Objective	.6X, 1.2X, 2.5X, 5X	.6X, 1X, 1.6X, 2.5X, 4X
Working distance	89mm	89mm
Field of view	23mm (w/377-456)	23mm (w/377-456)
Dimensions	H=14.6" x W=13" x D=11"	H=14.3" x W=13" x D=11"
Mass	15.5 lbs (7kg)	15.5 lbs (7kg)
Stand	Transmitted Light Stand (377-428)	Transmitted Light Stand (377-428)

* For Video System, see upper left table (optional accessories)

Stereo Microscopes

SERIES 377

377-990A/377-991A SYSTEM DIAGRAM

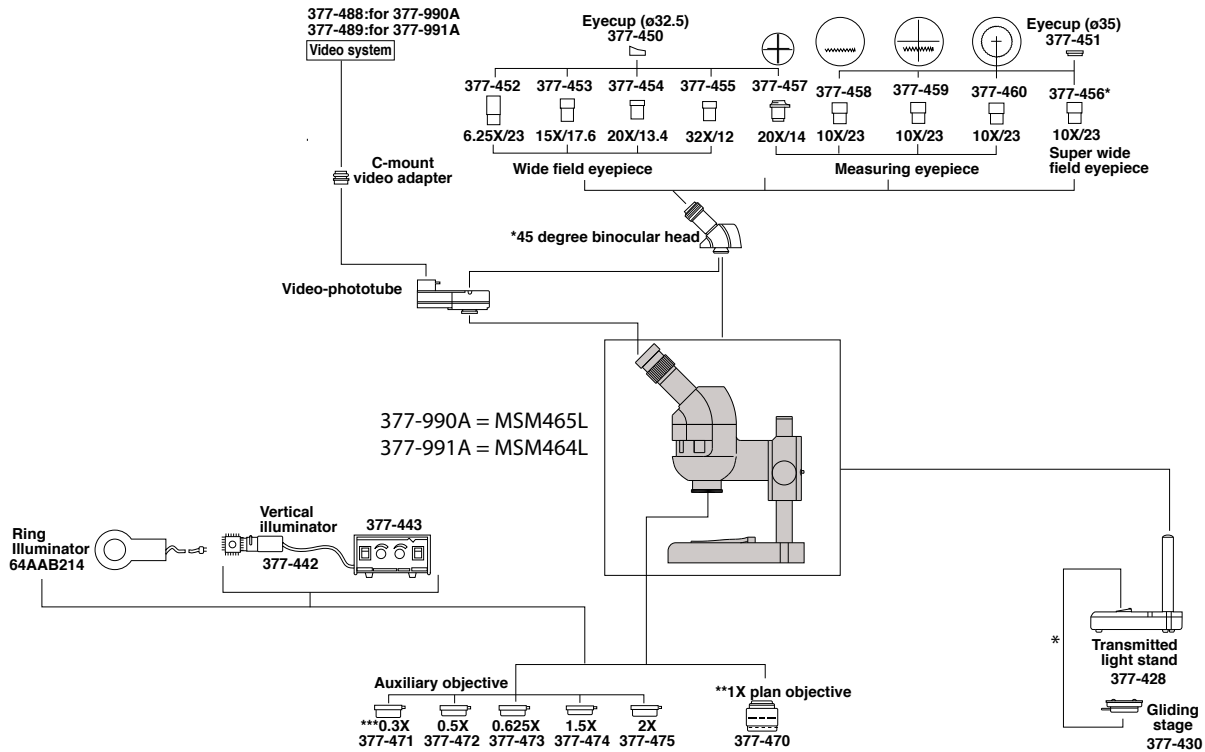

Optional Stand

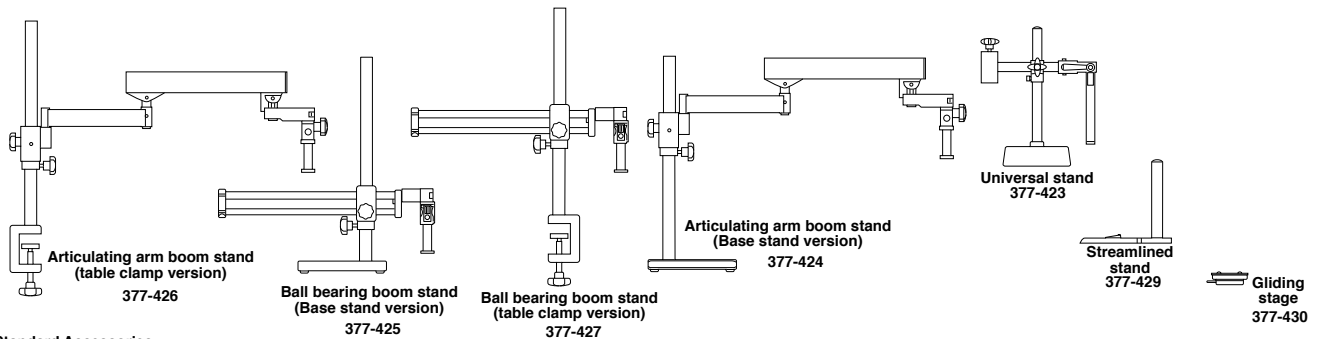

- * Standard Accessories
- ** 1X plan objective can replace 1X standard built-in objective
- *** 350mm long stand post is required. (377-431)

Pocket Magnifiers

SERIES 183

FEATURES

- Suitable for inspecting metal surfaces.

SPECIFICATIONS

Magnification	Order No.	Remarks
25X	183-201	Pen type
	183-202	With stand
50X	183-203	With stand



183-201



183-202



183-203

Optional Reticles for Pocket Comparators

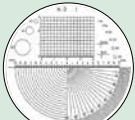

183-102

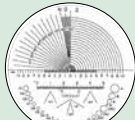

183-103



183-104

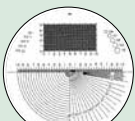

183-105



183-106

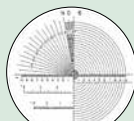

183-107

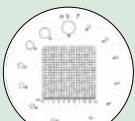

183-108

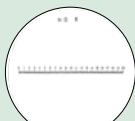

183-109



183-110



183-111

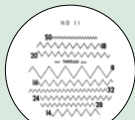

183-112



183-113



183-114

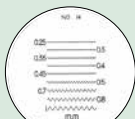

183-115

Pocket Comparator 8X with Reticles Set

Set No.

183-901 183-101, 183-106

183-902 183-101, 183-102, 183-106, 183-107, 183-112, 183-113, 183-114

183-903 183-101, 183-102, 183-106, 183-107, 183-109, 183-113, 183-115

183-904 183-101, 183-102

Pocket Comparators

SERIES 183

FEATURES

- By replacing optional reticles, dimensional, angle and other types of measurements can be performed.
- Illuminator (950757) is available.

SPECIFICATIONS

Magnification	Order No.	Remarks
8X	183-101	Optional reticles available
10X	183-131	Optional reticles available



183-101

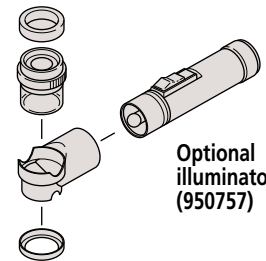

Optional illuminator (950757)

Zoom Loupe

SERIES 183

FEATURES

- Allows the user 8X - 16X zoom observation.
- Magnification indicator is provided for 8X, 10X, 12X, 14X and 16X observation.
- Metric and inch scales are provided for measuring.
- Comes with a carrying case.



183-304

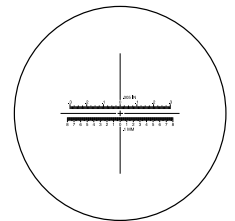

Reticle provided

SPECIFICATIONS

Magnification	Order No.	Remarks
8X - 16X	183-304	With reticle (Scale graduation: 0.1mm, .005")

Clear Loupe

SERIES 183



183-301



183-302



183-303

SPECIFICATIONS

Magnification	Order No.	Remarks
7X	183-301	Drawtube removable
10X	183-302	Drawtube removable
15X	183-303	Drawtube removable

Quick Guide to Precision Measuring Instruments

■ Erect Image and Inverted Image

An image of an object projected onto a screen is erect if it is orientated the same way as the object on the stage. If the image is reversed top to bottom, left to right and by movement with respect to the object on the stage (as shown in the figure below) it is referred to as an inverted image (also known as a reversed image, which is probably more accurate).

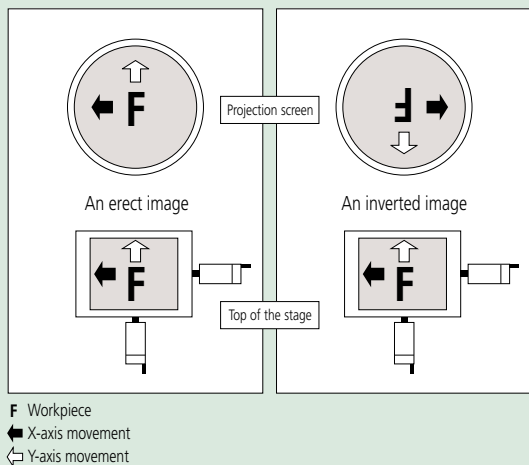

■ Magnification Accuracy

The magnification accuracy of a projector when using a certain lens is established by projecting an image of a reference object and comparing the size of the image of this object, as measured on the screen, with the expected size (calculated from the lens magnification, as marked) to produce a percentage magnification accuracy figure, as illustrated below. The reference object is often in the form of a small, graduated glass scale called a stage micrometer or standard scale, and the projected image of this is measured with a larger glass scale known as a reading scale.

(Note that magnification accuracy is not the same as measuring accuracy.)

$$\Delta M(\%) = \frac{L - \ell M}{\ell M} \times 100$$

$\Delta M(\%)$: Magnification accuracy expressed as a percentage of the nominal lens magnification

L : Length of the projected image of the reference object measured on the screen

ℓ : Length of the reference object

M : Magnification of the projection lens

■ Type of Illumination

- **Contour illumination:** An illumination method to observe a workpiece by transmitted light and is used mainly for measuring the magnified contour image of a workpiece.
- **Coaxial surface illumination:** An illumination method whereby a workpiece is illuminated by light transmitted coaxially to the lens for the observation/measurement of the surface. (A half-mirror or a projection lens with a built-in half-mirror is needed.)
- **Oblique surface illumination:** A method of illumination by obliquely illuminating the workpiece surface. This method provides an image of enhanced contrast, allowing it to be observed three-dimensionally and clearly. However, note that an error is apt to occur in dimensional measurement with this method of illumination. (An oblique mirror is needed. Models in the PJ-H30 series are supplied with an oblique mirror.)

■ Telecentric Optical System

An optical system based on the principle that the principal ray is aligned parallel to the optical axis by placing a lens stop on the focal point on the image side. Its functional feature is that the image will not vary in size though the image blurs as the object is shifted along the optical axis.

For measuring projectors and measuring microscopes, an identical effect is obtained by placing a lamp filament at the focal point of a condenser lens instead of a lens stop so that the object is illuminated with parallel beams. (See the figure below.)

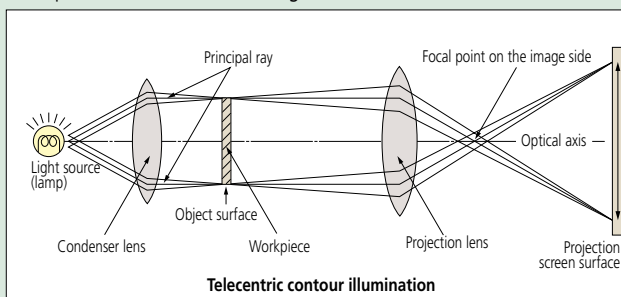

■ Working distance

Refers to the distance from the face of the projection lens to the surface of a workpiece in focus. It is represented by L in the diagram below.

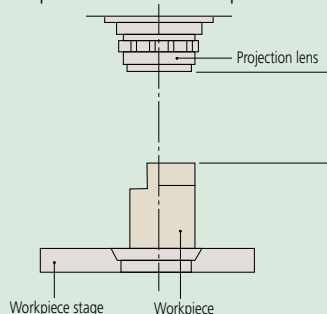

■ Parallax error

This is the displacement of an object against a fixed background caused by a change in the observer's position and a finite separation of the object and background planes.

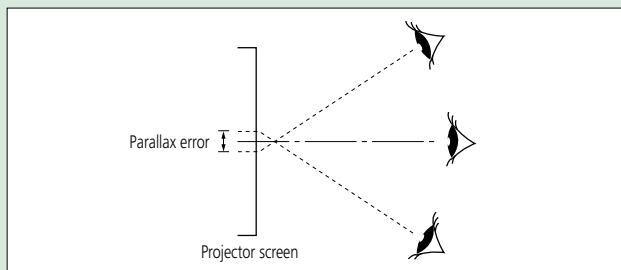

■ Field of view diameter

The maximum diameter of workpiece that can be projected using a particular lens.

$$\text{Field of view diameter (mm)} = \frac{\text{Screen diameter of profile projector}}{\text{Magnification of projection lens used}}$$

Example: If a 5X magnification lens is used for a projector with a screen of $\phi 500\text{mm}$:

$$\text{Field of view diameter is given by } \frac{500\text{mm}}{5} = 100\text{mm}$$

Numerical Aperture (NA)

The NA figure is important because it indicates the resolving power of an objective lens. The larger the NA value the finer the detail that can be seen. A lens with a larger NA also collects more light and will normally provide a brighter image with a narrower depth of focus than one with a smaller NA value.

$$NA = n \cdot \sin\theta$$

The formula above shows that NA depends on n , the refractive index of the medium that exists between the front of an objective and the specimen (for air, $n=1.0$), and angle θ , which is the half-angle of the maximum cone of light that can enter the lens.

Resolving Power (R)

The minimum detectable distance between two image points, representing the limit of resolution. Resolving power (R) is determined by numerical aperture (NA) and wavelength (λ) of the illumination.

$$R = \frac{\lambda}{2 \cdot NA} \text{ (}\mu\text{m)}$$

$\lambda = 0.55\mu\text{m}$ is often used as the reference wavelength

Working Distance (W.D.)

The distance between the front end of a microscope objective and the surface of the workpiece at which the sharpest focusing is obtained.

Parfocal Distance

The distance between the mounting position of a microscope objective and the surface of the workpiece at which the sharpest focusing is obtained. Objective lenses mounted together in the same turret should have the same parfocal distance so that when another objective is brought into use the amount of refocusing needed is minimal.

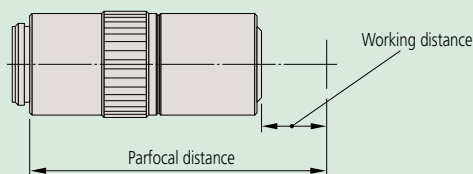

Infinity Optical System

An optical system where the objective forms its image at infinity and a tube lens is placed within the body tube between the objective and the eyepiece to produce the intermediate image. After passing through the objective the light effectively travels parallel to the optical axis to the tube lens through what is termed the infinity space within which auxiliary components can be placed, such as differential interference contrast (DIC) prisms, polarizers, etc., with minimal effect on focus and aberration corrections.

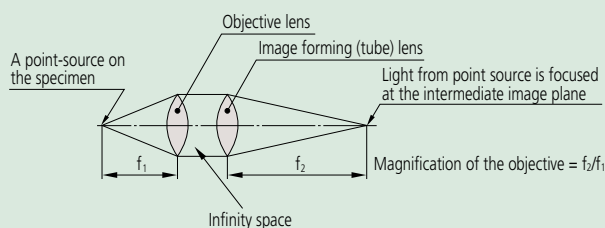

Finite Optical System

An optical system that uses an objective to form the intermediate image at a finite position. Light from the workpiece passing through the objective is directed toward the intermediate image plane (located at the front focal plane of the eyepiece) and converges in that plane.

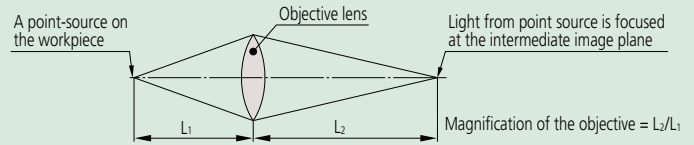

Focal Length (f)

unit: mm

The distance from the principal point to the focal point of a lens: if f_1 represents the focal length of an objective and f_2 represents the focal length of an image forming (tube) lens then magnification is determined by the ratio between the two. (In the case of the infinity-correction optical system.)

$$\text{Objective magnification} = \frac{\text{Focal length of the image-forming (tube) lens}}{\text{Focal length of the objective}}$$

$$\text{Example: } 1X = \frac{200}{200} \quad \text{Example: } 10X = \frac{200}{20}$$

Focal Point

Light rays traveling parallel to the optical axis of a converging lens system and passing through that system will converge (or focus) to a point on the axis known as the rear focal point, or image focal point.

Depth of Focus (DOF)

unit: mm

Also known as depth of field, this is the distance (measured in the direction of the optical axis) between the two planes which define the limits of acceptable image sharpness when the microscope is focused on an object. As the numerical aperture (NA) increases, the depth of focus becomes shallower, as shown by the expression below:

$$DOF = \frac{\lambda}{2 \cdot (NA)^2} \quad \lambda = 0.55\mu\text{m} \text{ is often used as the reference wavelength}$$

Example: For an **M Plan Apo 100X** lens ($NA = 0.7$)

The depth of focus of this objective is

$$\frac{0.55\mu\text{m}}{2 \times 0.7^2} = 0.6\mu\text{m}$$

Bright-field Illumination and Dark-field Illumination

In brightfield illumination a full cone of light is focused by the objective on the specimen surface. This is the normal mode of viewing with an optical microscope. With darkfield illumination, the inner area of the light cone is blocked so that the surface is only illuminated by light from an oblique angle. Darkfield illumination is good for detecting surface scratches and contamination.

Apochromat and Achromat Objectives

An apochromat objective is a lens corrected for chromatic aberration (color blur) in three colors (red, blue, yellow).

An achromat objective is a lens corrected for chromatic aberration in two colors (red, blue).

Quick Guide to Precision Measuring Instruments

■ Magnification

The ratio of the size of a magnified object image created by an optical system to that of the object. Magnification commonly refers to lateral magnification although it can mean lateral, vertical, or angular magnification.

■ Principal Ray

A ray considered to be emitted from an object point off the optical axis and passing through the center of an aperture diaphragm in a lens system.

■ Aperture Diaphragm

An adjustable circular aperture which controls the amount of light passing through a lens system. It is also referred to as an aperture stop and its size affects image brightness and depth of focus.

■ Field Stop

A stop which controls the field of view in an optical instrument.

■ Telecentric System

An optical system where the light rays are parallel to the optical axis in object and/or image space. This means that magnification is nearly constant over a range of working distances, therefore, almost eliminating perspective error.

■ Erect Image

An image in which the orientations of left, right, top, bottom and moving directions are the same as those of a workpiece on the workstage.

■ Field number (FN), real field of view, and monitor display magnification

unit: mm

The observation range of the sample surface is determined by the diameter of the eyepiece's field stop. The value of this diameter in millimeters is called the field number (FN). In contrast, the real field of view is the range on the workpiece surface when actually magnified and observed with the objective lens.

The real field of view can be calculated with the following formula:

(1) The range of the workpiece that can be observed with the microscope (diameter)

$$\text{Real field of view} = \frac{\text{FN of eyepiece}}{\text{Objective lens magnification}}$$

Example: The real field of view of a 1X lens is $24 = \frac{24}{1}$
 The real field of view of a 10X lens is $2.4 = \frac{24}{10}$

(2) Monitor observation range

$$\text{Monitor observation range} = \frac{\text{The size of the camera image sensor (diagonal length)}}{\text{Objective lens magnification}}$$

• Size of image sensor

Format	Diagonal length	Length	Height
1/3"	6.0	4.8	3.6
1/2"	8.0	6.4	4.8
2/3"	11.0	8.8	6.6

(3) Monitor display magnification

$$\text{Monitor display magnification} = \text{Objective lens magnification} \times \frac{\text{Display diagonal length on the monitor}}{\text{Diagonal length of camera image sensor}}$$