

Linear Encoder NC Linear Scale Systems

Catalog No. E13005(2)



Linear Encoders for
Numerical Motion/Position Control Systems

Mitutoyo

Integrated Production System for...

The Utsunomiya Operations Kiyohara Production Department presents a complete manufacturing environment where linear encoders for Mitutoyo measuring equipment as well as linear scales for the general market are produced. The whole production process including the manufacturing of glass scales for linear encoders, assembly of electronic components and products, and inspection is performed here. Conditions are continuously being optimized for further enhanced scale accuracy and even higher quality. The underground research laboratory at the Kiyohara Production Department has been specially designed and constructed to provide the environment required for the high-level scale graduation process as well as for high-accuracy measurements.

Located on a solid bedrock foundation nine meters underground, the facility maintains a stable and tightly controlled environment all year round. Temperature and humidity fluctuations as well as external vibrations are kept to an absolute minimum. In this laboratory, we produce master scales, perform accuracy evaluation, and pursue various kinds of research that provide the underpinning for the accuracy and quality of our linear scales.



Sputtering equipment

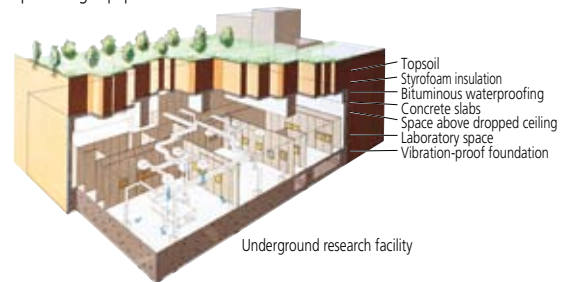

Underground research facility

Linear Encoder Accuracy Calibration Technology

To assure high accuracy in linear encoders, a highly reliable calibration system is indispensable. The ultra-precision length measuring machine developed by Mitutoyo and installed in the underground research facility at the Kiyohara Production Department benefits from the highly stable underground environment. In addition, the light path of the laser interferometer used to measure lengths is placed in a vacuum to further eliminate any causes of uncertainty. The result is a linear encoder calibration system of world-leading precision, internationally recognized by mutual interlaboratory comparisons. In recognition of the high technological standard realized by this system, it received the Best Paper Award of the Japan Society of Precision Engineering in 2004 and the FA Paper Award of the FANUC FA and Robot Foundation in 2005.



Ultra-precision length measuring machine with vacuum laser interferometer

Linear Scales from Mitutoyo are traceable to national standards

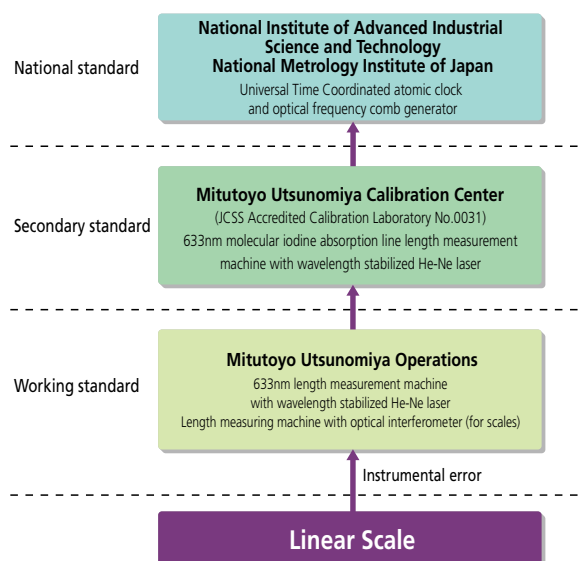

Linear Scale Traceability System Chart

NC Linear Scale Systems

Application	3
Detection Principle	4, 5
NC Linear Scale Systems – System Diagram	6
NC Linear Scale Systems – Overview	7
Separate Type ST Series	
ST36	8–11
ST46-EZA	12–22
Assembly Type AT Series	
AT402E	23–27
AT211	28–33
AT203	34–37
AT217-TL/AT217-TL-B	38–39

Absolute Scale Unit	40, 41
ABS ST700 Compact Type Series	42–47
ABS ST1300	48–53
ABS AT1100	54–59
ABS AT500 Series (0.001μm/0.005μm/0.01μm)	60–71
ABS AT500 Series (0.05μm)	72–79
Discontinued models and succession models specification compatibility tables	80
Handling linear scales	81
AT scale air supply	82, 83
Technical Information	84

Linear Scale is a registered trademark of Mitutoyo Corporation for its linear encoder products.

Applications

AT Series - Reference

Semiconductor fabrication equipment

Dicing saw positioning

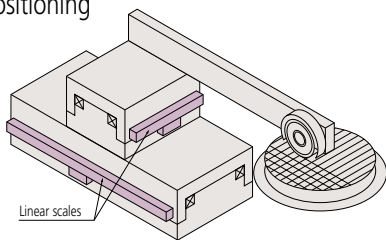

Various NC machine tools

High-precision fully closed loop control

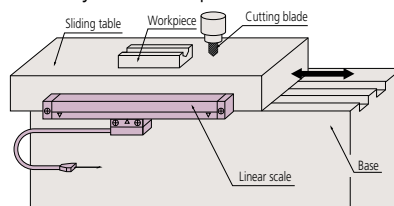

ST Series - Reference

Lithography equipment

Scanning stage positioning

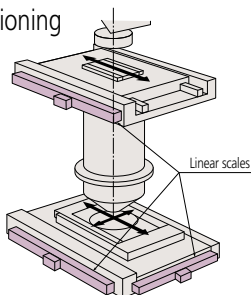

Electronic component inserter

High-speed, high-precision mounting of electronic components

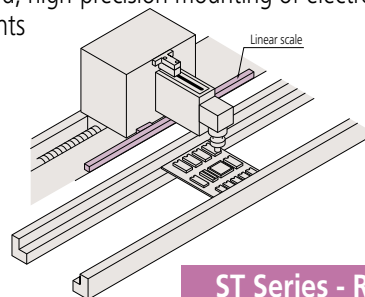

ST Series - Reference

Electron microscope

Mask observation, circuit pattern measurement, defect inspection, etc.

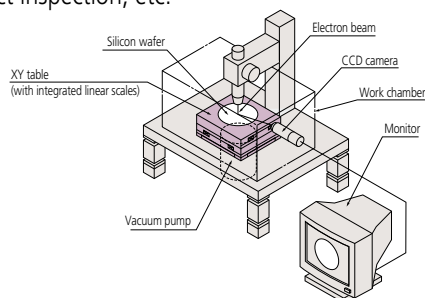

FPD inspection equipment

Defect inspection and repair position determination

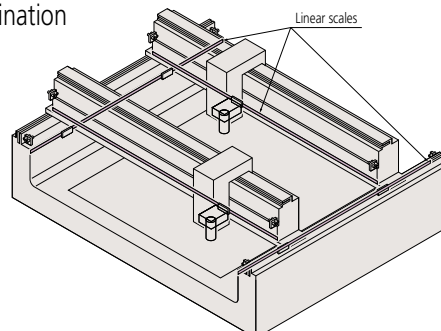

Detection Principle

Detection principle of the transmission photoelectric scale (Assembly Type Linear Scale)

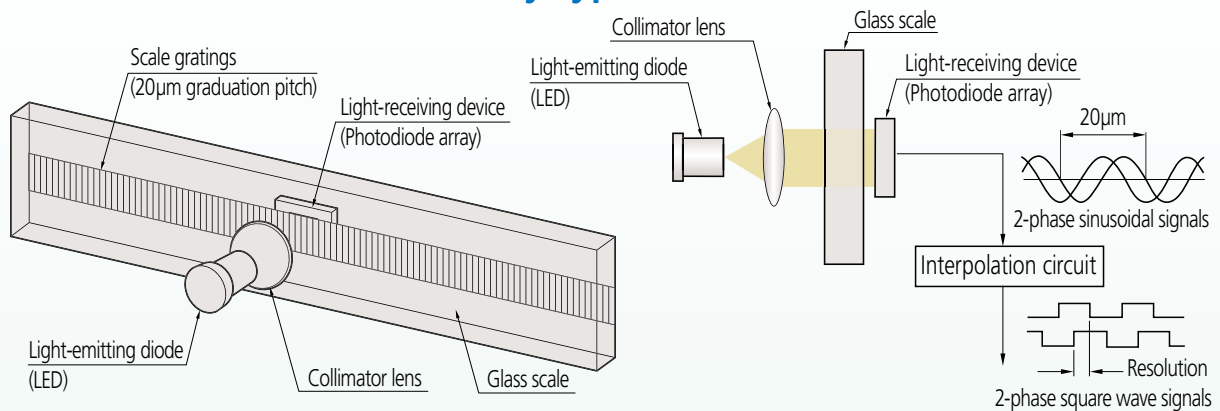

The assembly type linear scale uses a graduated glass scale as measuring length reference. A light-emitting diode (LED) and light-receiving device mounted on opposite sides of the scale serve to detect and detect changes in light intensity and output a value representing the displacement magnitude. Because the change in transmitted light intensity of the glass scale is converted into an electrical signal, the setup is called a transmission photoelectric system. A parallel light beam generated by the LED and collimator lens is directed through the scale gratings. A light-receiving device consisting of a photodiode array on the other side of the scale receives the parallel light beam and produces interference fringes with a cycle that corresponds to the scale grating pitch. When the glass scale is displaced in the measuring direction, the interference fringes shift, and a 2-phase sinusoidal signal with a cycle that corresponds to the 20µm pitch of the scale gratings is output by the light-receiving device. An interpolation circuit electrically divides the output sinusoidal signal, resulting in a square wave (pulse) signal representing the limiting resolution.

Detection principle of the reflective photoelectric scale (ST36, etc.)

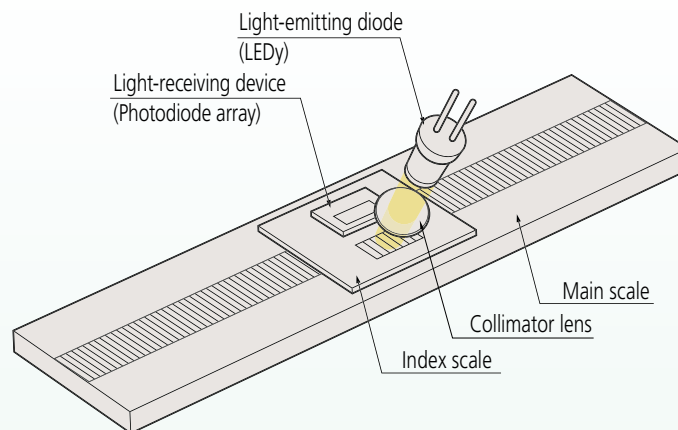

The separate type photoelectric linear scale also uses a graduated glass scale as measuring length reference. An LED and light-receiving device together with gratings on an index scale produce and detect changes in light intensity and output a value representing the displacement magnitude. Because the change in reflected light intensity of the glass scale is converted into an electrical signal, the setup is called a reflective type photoelectric system. A parallel light beam generated by the LED and collimator lens is directed onto the index scale gratings and the glass scale gratings. The light reflected from the scale gratings produces interference fringes on the photodiode array of the light-receiving device. When the glass scale is displaced in the measuring direction, the interference fringes shift, and a sinusoidal signal with a cycle that is the same as, or one-half of, the scale grating pitch is output by the light-receiving device.

Detection principle of electromagnetic induction system (ABS ST700, ABS AT1100)

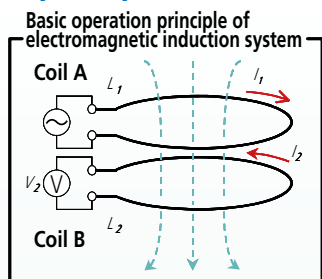

[Figure 1] Electromagnetic induction system encoder principle

When a current (I_1) that changes over time is passed through coil A, a magnetic flux is created in the vicinity of coil A. This causes an inductive current (I_2) to flow in coil B, in a direction that cancels out the magnetic field.

Magnetic permeability between coils is largely identical in air, water, or oil.

Electromagnetic induction type sensor has excellent water resistance and oil resistance.

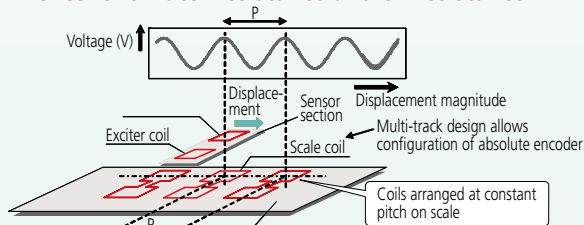

[Figure 2] Electromagnetic induction scale detection principle

Electromagnetic induction is a phenomenon that occurs, for example, when two coils are arranged facing each other, as shown in Figure 1, and a time-varying current (I_1) is passed through coil A. This will cause an induced current (I_2) to flow in coil B, in a direction that cancels out the magnetic field.

The electromagnetic induction type linear scale uses this phenomenon to convert a displacement magnitude into an electrical signal. The operational principle of the sensor section is shown in Figure 2. A number of scale coils are arranged with precise spacing on the main scale. The moveable sensor section that detects displacement carries an exciter coil and a corresponding detector coil. A current is sent through the exciter coil, thereby creating a magnetic flux that induces a current in the facing scale coil. The magnetic flux created in turn by that current induces a current in the facing detector coil. The degree of inductive coupling between the coils changes according to the displacement magnitude of the sensor section, allowing a sinusoidal signal with a cycle that corresponds to the pitch of the scale coils to be obtained.

By using an electrical circuit that performs interpolation (division) of this sinusoidal signal, displacement can be measured with fine resolution.

Telecentric Principle (ABS ST1300)

Reflective photoelectric linear encoder equipped with two-sided telecentric imaging

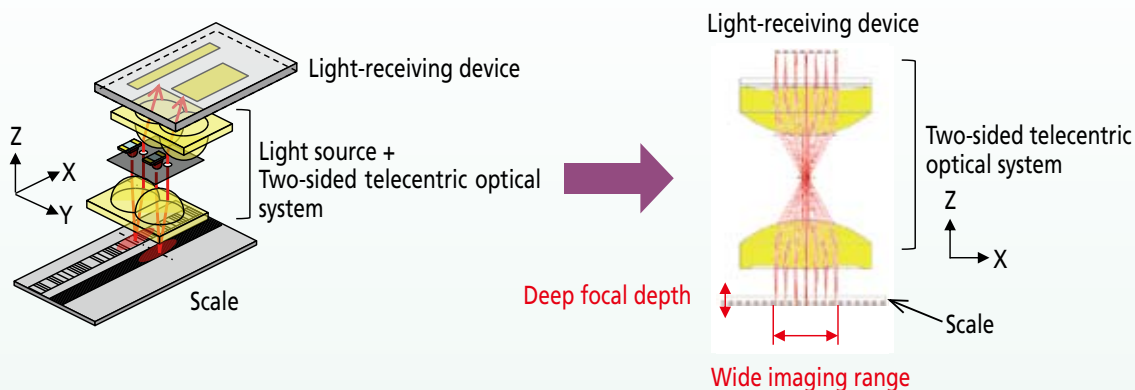

Detection Principle

• The scale grating is captured as an image with the two-sided telecentric optical system and its displacement is detected with a light-receiving device.

Features

• Adoption of a two-sided telecentric imaging optical system ⇒ Improves the robustness of the encoder.

- The deep focal depth ⇒ Extends allowance for gap variation (scale waviness and stage orientation variation, detector mounting variation, etc.).
- The wide imaging range ⇒ Extends allowance for contamination, slight damage, etc. on the scale.

NC Linear Scale Systems – System Diagram

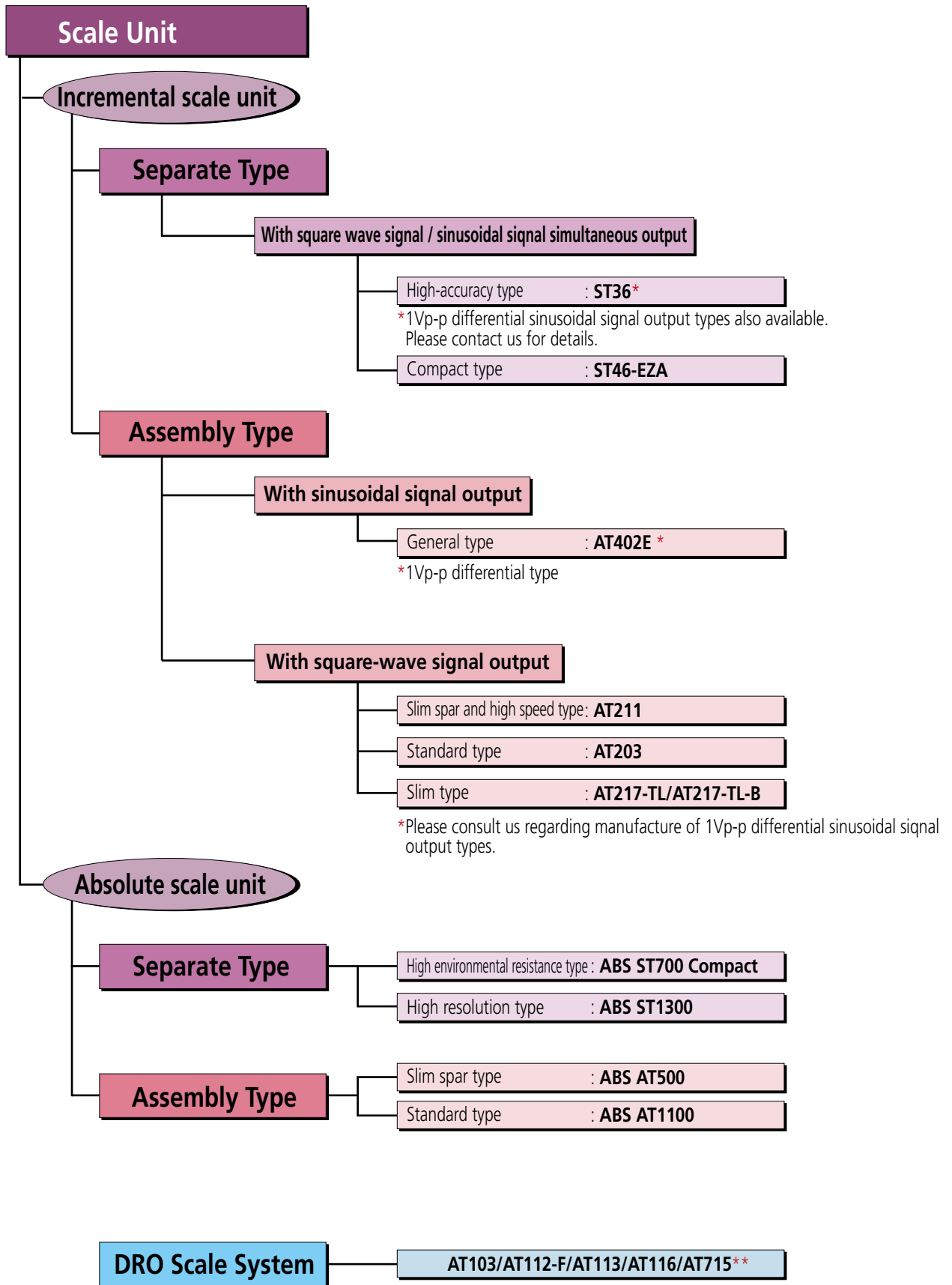

**Refer to the Linear Scale DRO Systems (Catalog No. E13000).

NC Linear Scale Systems – Overview

△ : Compatible (with limitations)

	Scale name (Code)	Reference point	Absolute function	Output signal cycle of sinusoidal signal	Signal unit	No. of divisions	Resolution	Maximum range	Maximum response speed* ¹	Minimum edge interval* ²	See page	
Separate Type Linear Scales	ST36B ST36C (ST36A) (ST36D)	Yes	No	4μm	- (PSU-200)	400	0.01μm	3000mm	70mm/s	125ns	P8 - 11	
						200	0.02μm		150mm/s			
						80	0.05μm		260mm/s			
						40	0.1μm		720mm/s			
	ST46-EZA	Yes	No	20μm	-	400	0.05μm	3000mm	450mm/s	100ns	P12 - 22	
						200	0.1μm		900mm/s			
						40	0.5μm		2600mm/s			
						20	1μm		2600mm/s			
	ABS ST700 Compact type	-	Yes	-	-	-	-	0.1μm	6000mm	5000mm/s	-	P42 - 47
AT402E	Yes	△	20μm	-	-	-	3040mm	2000mm/s	1Vp-p differential sine wave	P23 - 27		
Assembly Type Linear Scales	AT211	Yes	No	-	-	200	0.1μm	1500mm	710mm/s	125ns	P28 - 33	
						100	0.2μm		1400mm/s			
						40	0.5μm		2000mm/s			250ns
						20	1μm					500ns
						8	2.5μm					1000ns
						4	5μm					
	AT203	Yes	No	-	-	200	0.1μm	6000mm	333mm/s	250ns	P34 - 37	
						40	0.5μm		1833mm/s			
						20	1μm		2000mm/s			
	AT217-TL/ AT217-TL-B	Yes	No	20μm	-	20	1μm	1500mm	833mm/s	800ns	P38 - 39	
ABS AT500 * ⁵												-
	ABS AT1100	-	Yes	-	-	-	-	0.05μm	3040mm	3000mm/s	-	

*1 Maximum response speed of pulse output type uses the logical value (IC specification) with a margin of about 10%.

*2 For information on minimum edge interval, see "Explanation of Terms" on page 86.

The guaranteed value for minimum edge interval is +0%, -10%.

For some models, values other than shown above can also be selected.

*3 It depends on the interface.

*4 Maximum response speed of H type with 0.005μm resolution is 1200mm/s.

*5 Resolution and maximum response speed of Siemens IF are different from the above table.

Separate Type ST Series

Sinusoidal signal & Square-Wave Signal Output Scale Unit (High Accuracy Type)

ST36



Features

- High accuracy type, 0.5μm class (effective range up to 300mm)
- Has a thinner detector head (thickness 11.5mm).
- The maximum effective measurement length of 3000mm enables use on large machines.
- 4 different types available for each signal output specification.
- LED display function for indicating signal errors.

Specifications

Item	Code	ST36A	ST36B	ST36C	ST36D
Detection method		Reflective photoelectric linear encoder			
Main scale grating pitch		8μm			
Signal output pitch		4μm			
Output signal		2-phase sinusoidal signals	2-phase square wave signals (reset input type)	2-phase square wave signals 2-phase sinusoidal signals	1Vp-p differential sinusoidal signals
Effective range		10 - 3000mm			
Accuracy (20°C)		Effective range 10 to 300mm: ±0.5 μm Effective range 350 to 500mm: ±1.0μm Effective range 600 to 1000mm: ±2.0μm Effective range 1100 to 3000mm: ±2.0μm/m			
Thermal expansion coefficient		≈ 8 × 10 ⁻⁶ / K			
Maximum response speed		1200mm/s (with sinusoidal signals output) (For 2-phase square wave signal types, see page 10)			
Scale reference point*		With scale reference point (50mm pitch, 10 to 80mm: Center point)			
Power supply		5VDC±5%			
Maximum current consumption		120mA	250mA		190mA
Operating temperature/humidity		0 to 40°C, 20 to 80% RH (no condensation)			
Storage temperature/humidity		-20 to 60°C, 20 to 80%RH (no condensation)			
Alarm indication		A scale alarm is indicated with an LED on the I/F box			

*Maximum speed for scale reference point detection is 20mm/s.

Parts

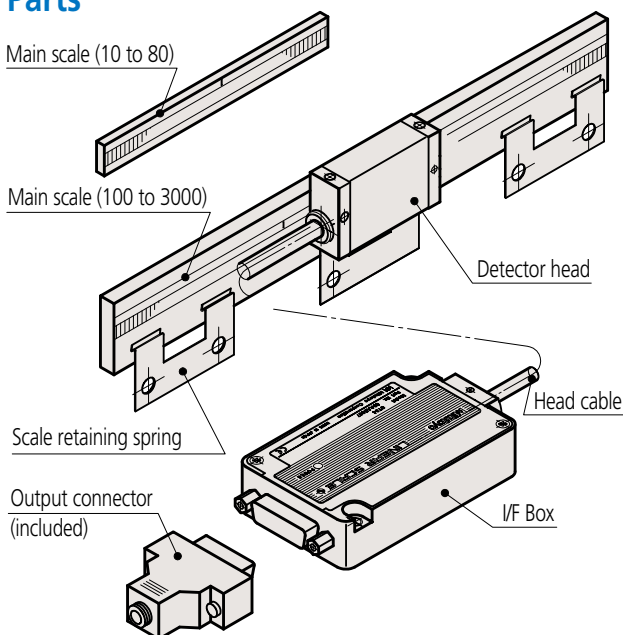

Alarm reset transmission/reception signal circuit (B Type)

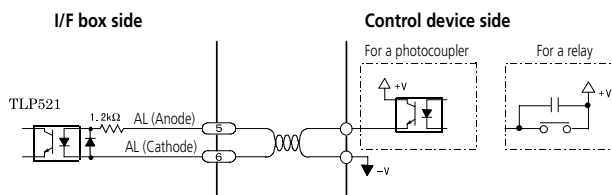

Reset input

Connect the alarm reset input circuit so that the current is 3 to 10mA. Also, the device has an internal resistor (1.2kΩ), so by applying 5 to 12V with a pulse width of at least 10ms across AL (anode)-AL (cathode), the alarm can be reset. When applying 12V or more, add an external resistance to limit the current to within the range stated above.

Output signal waveform

• 2-phase sinusoidal signals (Type A, C)

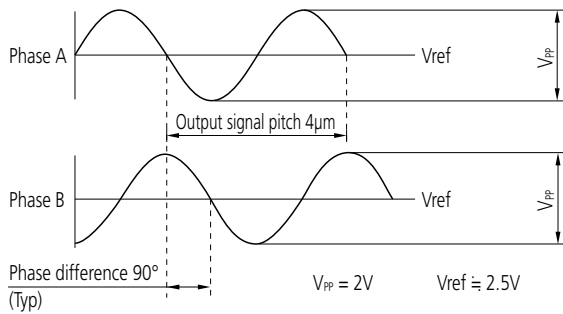

• Scale reference point

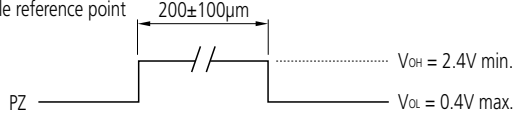

(Note) The phase difference between the PZ signal and the Phase A signal (and the Phase B signal) are not defined.

• 2-phase square wave signals (Type B, C)

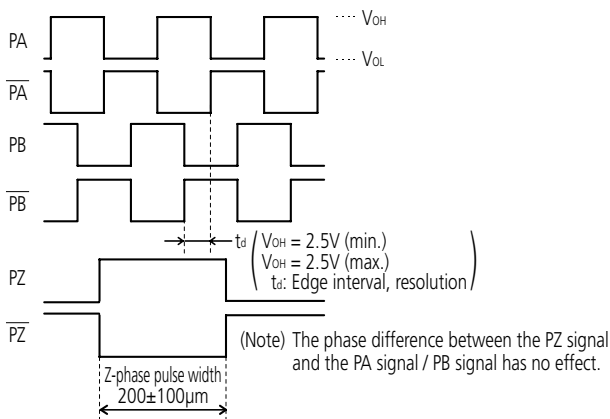

• 1Vp-p differential sinusoidal signals (Type D)

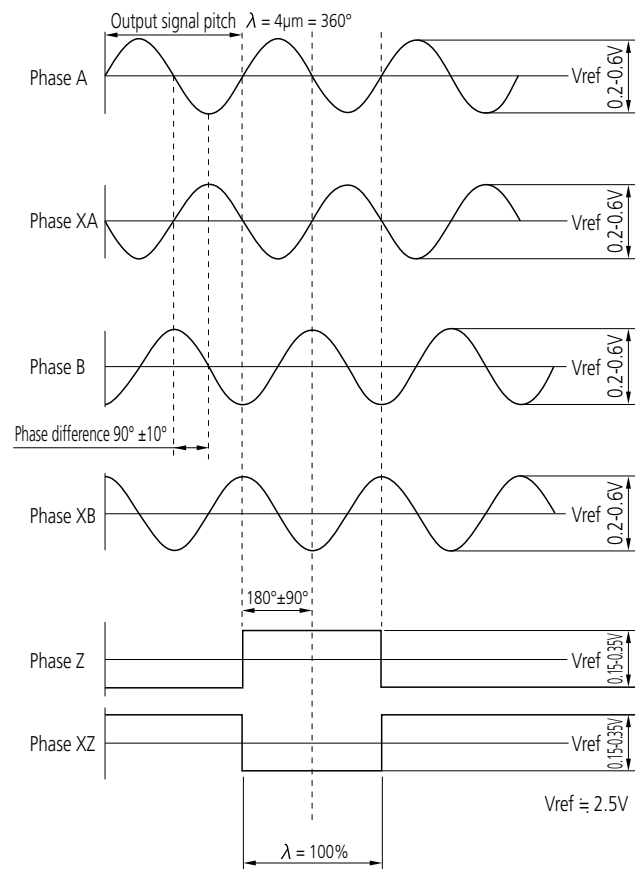

Output specification

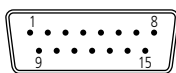

1. Output connector specification (Type A, B, C)

- Output connector (pin type): RDAD-15P-LNA(05) (Hirose Electric or equivalent)
- Applicable connector (standard accessory): D15-403N-110 (Technical Electron or equivalent)

2. Output connector specification (Type D)

- Output connector (pin type): RDAD-15P-LNA(05) inch screws (Hirose Electric or equivalent)
- Applicable connector (standard accessory): D15-403N-150 inch screws (Technical Electron or equivalent)

Pin No.	Type A Signal	Type B Signal	Type C Signal	Type D Signal
1	0V (GND)	0V (GND)	0V (GND)	Phase XA
2	0V (GND)	0V (GND)	0V (GND)	Phase XB
3	+5V	+5V	+5V	Phase Z
4	+5V	+5V	+5V	+5V (V_{DD})
5	Phase A	Reset input (anode)	Phase A	+5V (V_{DD})
6	Phase B	Reset input (cathode)	Phase B	N.C
7	Vref	Vref	Vref	N.C
8	PZ (scale reference point)	PZ (scale reference point)	PZ (scale reference point)	N.C
9	N.C	ALM (alarm, negative logic)	ALM (alarm, negative logic)	Phase A
10	Vref	PA	PA	Phase B
11	N.C	\overline{PA}	\overline{PA}	Phase XZ
12	N.C	PB	PB	0V (GND)
13	N.C	\overline{PB}	\overline{PB}	0V (GND)
14	N.C	PZ	PZ	N.C
15	F.G	F.G (= 0V)	F.G (= 0V)	0V (GND)

Specification Selection Method

- There is an extensive selection of specifications for ST36.
 - Choose the appropriate numbers and letters below according to specification required.
- If standard specifications (recommended items marked with ●/◎ symbols below) meet your requirements, please order using the code numbers shown on page 11.

How to read the code

ST36 - - - -

Signal output

Code	Output
A	Sinusoidal signal
B	Square wave signal + external reset input
C	Sinusoidal signal + Square wave signal
D	1Vp-p differential

Effective range

Code	Effective range (mm)	Code	Effective range (mm)
0010	10	0900	900
0025	25	1000	1000
0050	50	1100	1100
0075	75	1200	1200
0080	80	1300	1300
0100	100	1400	1400
0150	150	1500	1500
0200	200	1600	1600
0250	250	1700	1700
0300	300	1800	1800
0350	350	2000	2000
0400	400	2200	2200
0450	450	2400	2400
0500	500	2500	2500
0600	600	2600	2600
0700	700	2800	2800
0800	800	3000	3000

Note: For the standard specification, the indicated effective range depends on the product code.

Example of standard specification
 Effective range 10mm: ST36 -0010
 Effective range 250mm: ST36 -0250

Scale reference point

Code	Details
●A	50mm pitch (100 to 3000)
◎B	Center point (10 to 3000)
Z	Special position specification

Note: For reference positions in the effective range of 10 to 80mm, [B: Center point] is the standard specification.

Resolution / Minimum edge interval

Resolution	Minimum edge interval			
	125ns	250ns	500ns	1000ns
0.01μm	A: 70mm/s	B: 30mm/s	C: 15mm/s	D: 8mm/s
0.02μm	E: 150mm/s	F: 70mm/s	G: 30mm/s	H: 15mm/s
0.05μm	J: 360mm/s	K: 180mm/s	L: 90mm/s	M: 45mm/s
0.1 μm	N: 720mm/s	●P: 360mm/s	Q: 180mm/s	R: 90mm/s
—	◎Z: When [Signal output] is [A][D], maximum response speed at Sinusoidal signal -3 dB attenuation is 1.2m/s.			

Note: The minimum edge interval varies 0 to -10% based on the operating environmental conditions.

Special codes

Code	Details
●None	Standard selection specification
Z	Special specification

Note: If there are special details, please select Z.

Head cable length

Code	Length
●A	1m (High flex)
B	0.5m (High flex)
Z	Special length specification (max. 2.5m)

Note: If there are special details, please select Z.

Alarm output

Code	Details
●S	Alarm signal
H	High impedance
◎Z	When [Signal output] is [A] or [D]

Direction

Code	Details
●1	Normal: PA goes ahead
2	Reverse: PB goes ahead
◎Z	When [Signal output] is [A] or [D]

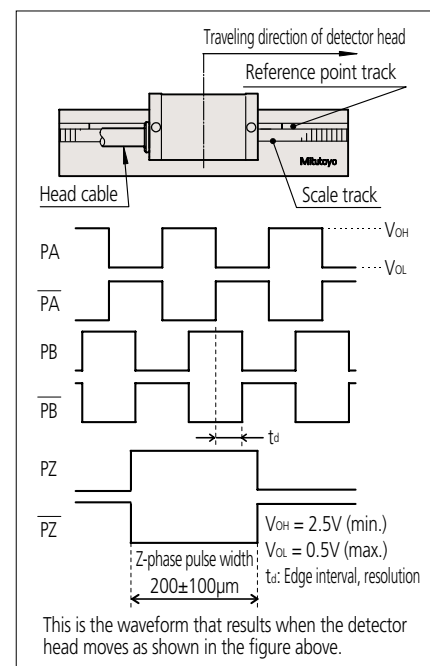

Mounting dimensions

• 10 to 80mm (Adhesive fixing type)

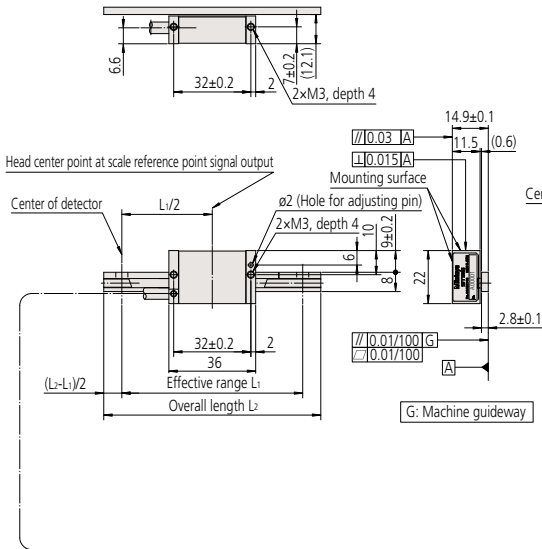

• 100 to 3000mm

Unit: mm

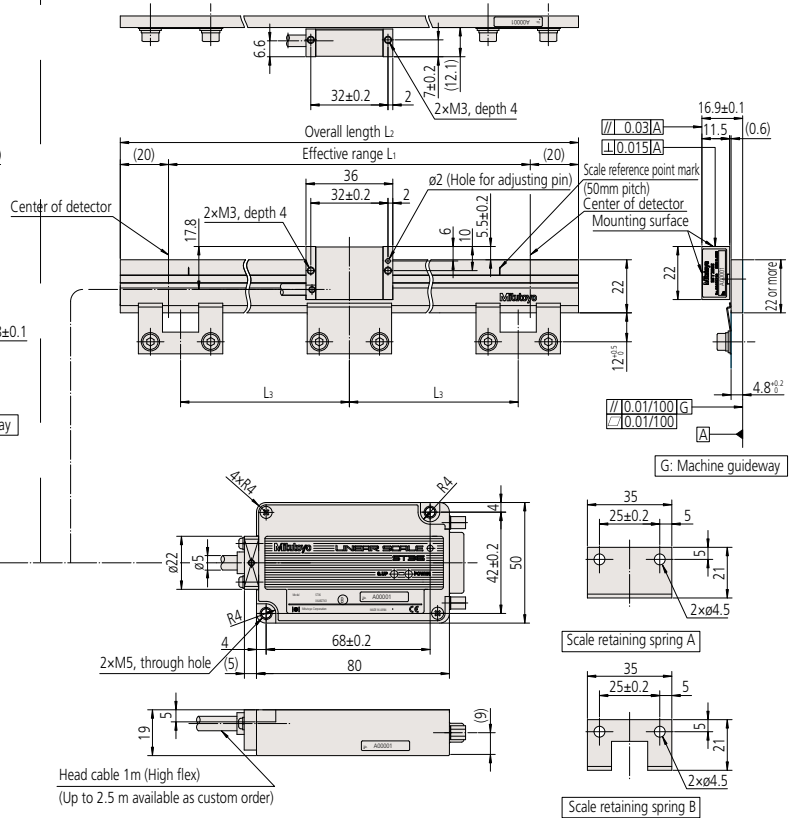

Dimensions of scale units

Order No.*	Code*	Effective range L ₁ (mm)	Overall length L ₂ (mm)	Scale fixing pitch L ₃ (mm)	Retaining spring A	Retaining spring B
579-501-0□	ST36◇-10	10	30	-	-	-
579-502-0□	ST36◇-25	25	45	-	-	-
579-503-0□	ST36◇-50	50	70	-	-	-
579-504-0□	ST36◇-75	75	90	-	-	-
579-505-0□	ST36◇-80	80	100	-	-	-
579-506-0□	ST36◇-100	100	140	50	1 pc.	2 pcs.
579-507-0□	ST36◇-150	150	190	75	1 pc.	2 pcs.
579-508-0□	ST36◇-200	200	240	100	1 pc.	2 pcs.
579-509-0□	ST36◇-250	250	290	60	1 pc.	4 pcs.
579-510-0□	ST36◇-300	300	340	75	1 pc.	4 pcs.
579-511-0□	ST36◇-350	350	390	85	1 pc.	4 pcs.
579-512-0□	ST36◇-400	400	440	100	1 pc.	4 pcs.
579-513-0□	ST36◇-450	450	490	75	1 pc.	6 pcs.
579-514-0□	ST36◇-500	500	540	80	1 pc.	6 pcs.
579-515-0□	ST36◇-600	600	640	100	1 pc.	6 pcs.
579-516-0□	ST36◇-700	700	740	85	1 pc.	8 pcs.
579-517-0□	ST36◇-800	800	840	100	1 pc.	8 pcs.

Order No.*	Code*	Effective range L ₁ (mm)	Overall length L ₂ (mm)	Scale fixing pitch L ₃ (mm)	Retaining spring A	Retaining spring B
579-518-0□	ST36◇-900	900	940	90	1 pc.	10 pcs.
579-519-0□	ST36◇-1000	1000	1040	100	1 pc.	10 pcs.
579-520-0□	ST36◇-1100	1100	1140	90	1 pc.	12 pcs.
579-521-0□	ST36◇-1200	1200	1240	100	1 pc.	12 pcs.
579-522-0□	ST36◇-1300	1300	1340	130	1 pc.	10 pcs.
579-523-0□	ST36◇-1400	1400	1440	100	1 pc.	14 pcs.
579-524-0□	ST36◇-1500	1500	1540	125	1 pc.	12 pcs.
579-525-0□	ST36◇-1600	1600	1640	100	1 pc.	16 pcs.
579-526-0□	ST36◇-1700	1700	1740	120	1 pc.	14 pcs.
579-527-0□	ST36◇-1800	1800	1840	100	1 pc.	18 pcs.
579-528-0□	ST36◇-2000	2000	2040	100	1 pc.	20 pcs.
579-529-0□	ST36◇-2200	2200	2240	100	1 pc.	22 pcs.
579-530-0□	ST36◇-2400	2400	2440	100	1 pc.	24 pcs.
579-531-0□	ST36◇-2500	2500	2540	95	1 pc.	26 pcs.
579-532-0□	ST36◇-2600	2600	2640	100	1 pc.	26 pcs.
579-533-0□	ST36◇-2800	2800	2840	100	1 pc.	28 pcs.
579-534-0□	ST36◇-3000	3000	3040	100	1 pc.	30 pcs.

* The above code numbers are for recommended items marked with ●/◎ symbols. If recommended specifications meet your requirements, use these code numbers to order.

* The □ and ◇ symbols in the tables above have the following meanings:
 ◇→A (2-phase sinusoidal signals) : □→1
 ◇→B (2-phase square wave signals + reset input) : □→2
 ◇→C (2-phase sinusoidal signals + 2-phase square wave signals) : □→3
 ◇→D (1Vp-p differential) : □→4

Separate Type ST Series

Sinusoidal signal & Square-Wave Signal Output Scale Unit (Compact Type)

ST46-EZA Glass Scale Type

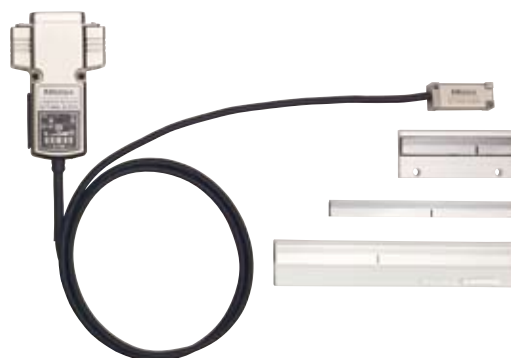

Separate Type ST Series
ST46-EZA

Features

- Includes an automatic adjusting function for the signal (EZA function) at the push of a button.
- Detector head mounting and signal adjustment possible without oscilloscope or PC.
- A setup indicator for checking signal strength is included.
- I/F circuit integrated in connector shell reduces volume to 60% compared to conventional interface.
- The thickness of the detector head is only 7.5 mm. The metal tape scale type has a mounting surface area of 12.5 by 9.325 mm, allowing use in applications where a space-saving design is important.

Specifications

Item	Code	ST46-EZA
Detection method		Reflective photoelectric linear encoder
Scale specifications		Grating pitch: 20μm, Material: glass
Main scale grating pitch		20μm
Output signal		Type B: 2-phase square wave signals, reference point pulse, external reset input Type C: 2-phase square wave signals, reference point pulse, 2-phase sinusoidal signals
Effective range		10 to 3000mm
Accuracy (20°C)		Effective range 10 to 300mm: ±1μm Effective range 350 to 500mm: ±2μm Effective range 600 to 1000mm: ±3μm Effective range 1100 to 3000mm: ±3μm/m
Thermal expansion coefficient		≈ 8 x 10 ⁻⁶ / K
Scale reference point		With scale reference point (50mm pitch, 10 to 80mm: Center point)
Maximum response speed		2.6m/s (at sine wave amplitude -3dB)
Power supply voltage		5VDC±5%
Maximum current consumption		250mA
Operating temperature/humidity		0 to 40°C, 20 to 80%RH (no condensation)
Storage temperature/humidity		-20 to 60°C, 20 to 80%RH (no condensation)

System Configuration

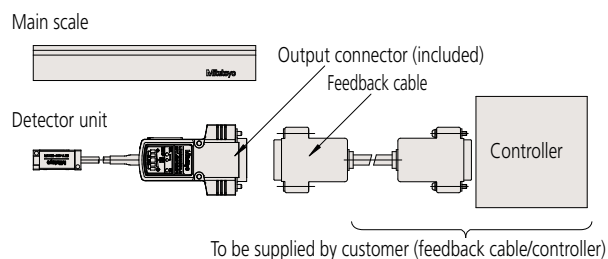

Output specification

- Connector pin assignment (Type B)

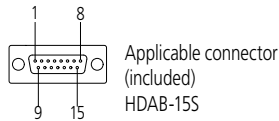

Pin No.	Signal	Pin No.	Signal
1, 2	0V (GND)	10	PA (main signal pulse_Normal phase)
3, 4	+5V (Vcc)	11	PA (main signal pulse_Reverse phase)
5	Reset input AL (anode)	12	PB (main signal pulse_Normal phase)
6	Reset input AL (cathode)	13	PB (main signal pulse_Reverse phase)
7	NC	14	PZ (reference point pulse_Reverse phase)
8	PZ (reference point pulse_Normal phase)	15	F. G
9	ALM (alarm)		

- Connector pin assignment (Type C)

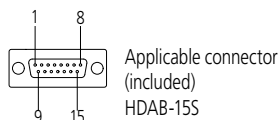

Pin No.	Signal	Pin No.	Signal
1, 2	0V (GND)	10	PA (main signal pulse_Normal phase)
3, 4	+5V (Vcc)	11	PA (main signal pulse_Reverse phase)
5	Phase A (sinusoidal signal)	12	PB (main signal pulse_Normal phase)
6	Phase B (sinusoidal signal)	13	PB (main signal pulse_Reverse phase)
7	Vref ($\approx V_{cc} / 2$)	14	PZ (reference point pulse_Reverse phase)
8	PZ (reference point pulse_Normal phase)	15	F. G
9	ALM (alarm)		

- Application program (Option, Part No.06AEF800)

Connector control unit has setup indicator

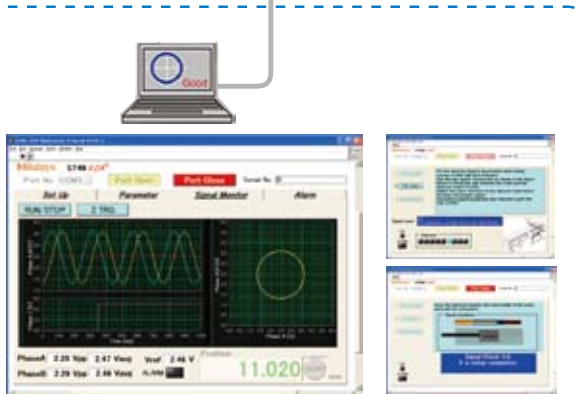
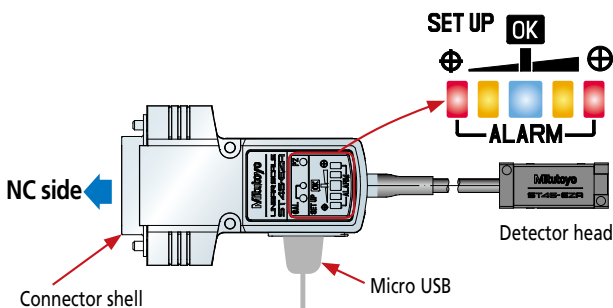

Signal strength checking and parameter setup can be performed on a PC (PC to be prepared by customer)

Output signal waveform and specification

- 2-phase square wave signals (Type B)

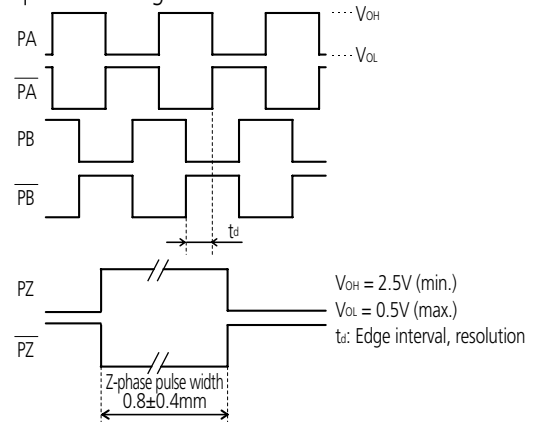

- 2-phase sinusoidal signals, 2-phase square wave signals (Type C)

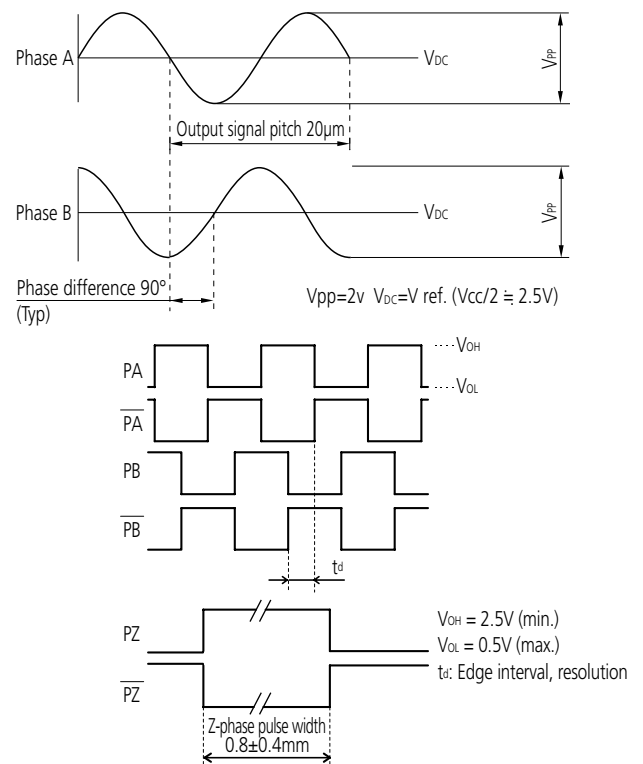

Specification Selection Method

(Glass Scale Type)

How to read the code

ST46-EZA - -

Signal output

Code	Details
B	Square wave signal + external reset input
C	Sinusoidal signal + Square wave signal

Special codes

Code	Details
●None	Standard selection specification
Z	Special specification

Effective range

Code	Effective range (mm)	Code	Effective range (mm)	Code	Effective range (mm)
0010	10	0450	450	1600	1600
0025	25	0500	500	1700	1700
0050	50	0600	600	1800	1800
0075	75	0700	700	2000	2000
0080	80	0800	800	2200	2200
0100	100	0900	900	2400	2400
0150	150	1000	1000	2500	2500
0200	200	1100	1100	2600	2600
0250	250	1200	1200	2800	2800
0300	300	1300	1300	3000	3000
0350	350	1400	1400		
0400	400	1500	1500		

Head cable length

Code	Length
●A	1m (standard)
B	0.5m
C	2m
Z	Special length specification (max. 2.5m)

Alarm output

Code	Details
●S	Alarm signal
H	High impedance

Direction

Code	Details
●1	Normal
2	Reverse

Note: For the standard specification, the indicated effective range depends on the product code.

Example of standard specification
 Effective range 10mm: **ST46EZA** **0010**
 Effective range 250mm: **ST46EZA** **0250**

- There is an extensive selection of specifications for the ST46-EZA.
- Choose the appropriate numbers and letters below according to specification required. If standard specifications (recommended items marked with ● symbol below) meet your requirements, please order using the code numbers shown on pages 19 - 20.

Reference point/ Scale shape

Code	Details (Effective range)	Details - Cross-section (Effective range)
●A	50mm pitch (100 to 3000mm)	Glass, separate: t4.8 x w22 (100 to 3000mm)
●B	Center point (10 to 80mm)	Glass, separate: t2.8 x w8 (10 to 80mm)
●C	Center point (10 to 80mm)	With aluminum base: t5.1 x w23 (10 to 80mm)
Z	Special position specification	Special shape

When the direction is normal, the sinusoidal signal, the 2-phase square wave output signal (Phase A, Phase B) and the reference point signal waveform are as shown below.

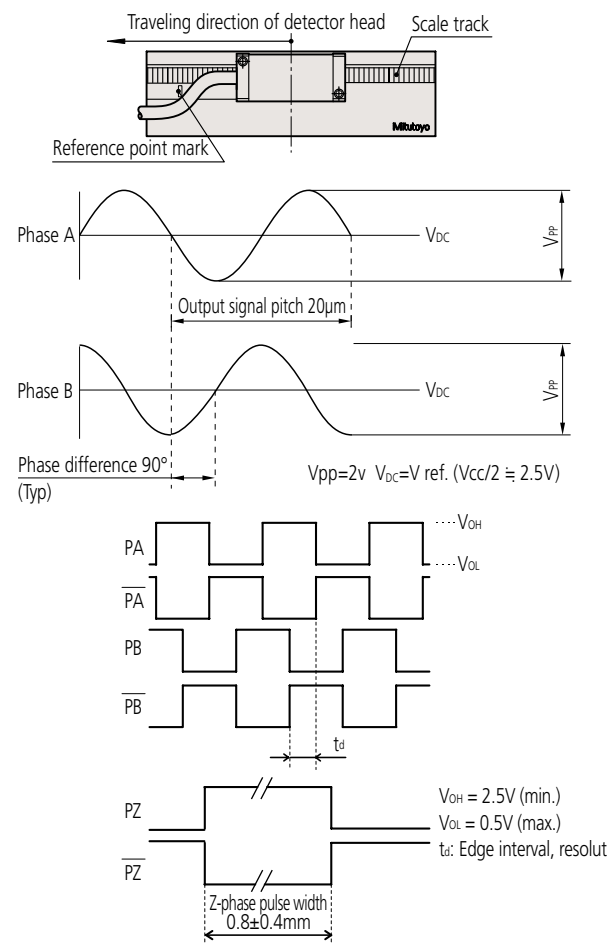

Resolution / Minimum edge interval

Code	Resolution	Minimum edge interval	Maximum response speed
A	0.05 μm	100 ns	450 mm/s
B		200 ns	225 mm/s
C		400 ns	112 mm/s
D		800 ns	56 mm/s
E	0.1 μm	100 ns	900 mm/s
●F		200 ns	450 mm/s
G		400 ns	225 mm/s
H		800 ns	112 mm/s
J	0.5 μm	100 ns	2600 mm/s
K		200 ns	2250 mm/s
L		400 ns	1125 mm/s
M		800 ns	562 mm/s
N	1 μm	100 ns	2600 mm/s
P		200 ns	2250 mm/s
Q		400 ns	1125 mm/s
R		800 ns	562 mm/s
S	5 μm	100 ns	2600 mm/s
T		200 ns	2600 mm/s
U		400 ns	2600 mm/s
V		800 ns	2600 mm/s



Separate Type ST Series ST46-EZA

(Glass Scale Type)

ST46-EZA Scale unit mounting dimensions

- Effective range 10 to 80mm (No aluminum base)

- Effective range 10 to 80mm (With aluminum base)

Unit: mm

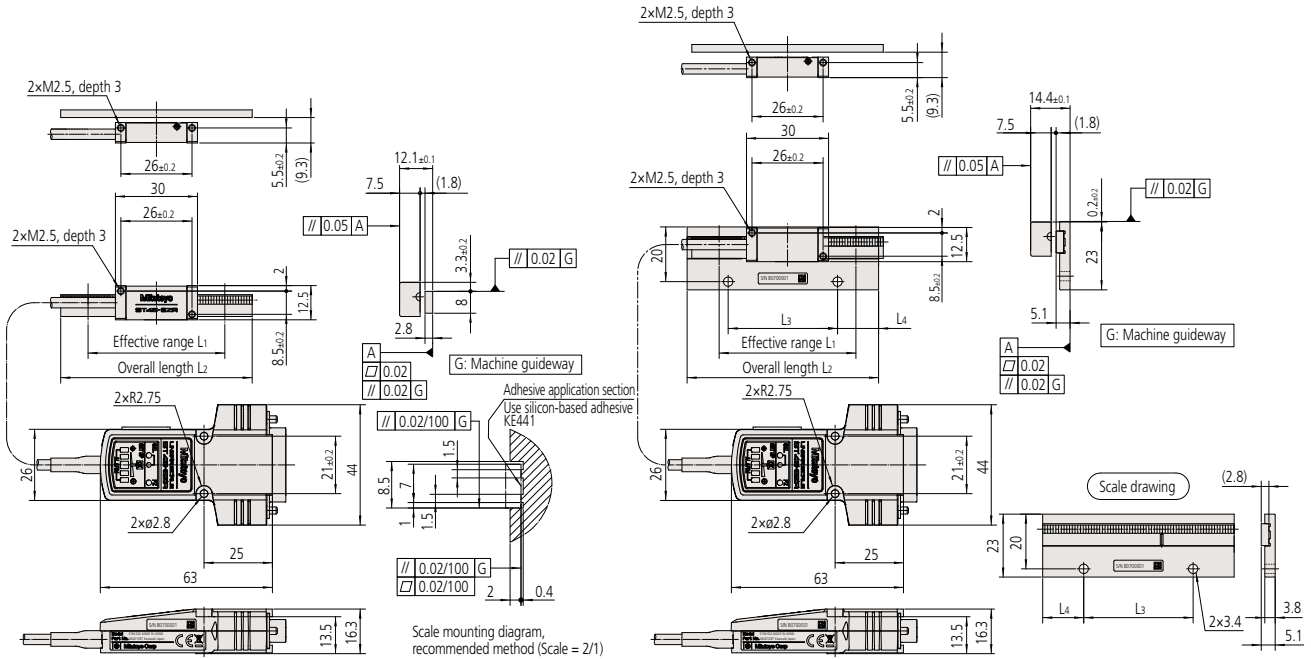

Dimensions of scale units

- 10 to 80mm (No aluminum base)

- 10 to 80 mm (With aluminum base)

Order No.	Code	Effective range L ₁ (mm)	Overall length L ₂ (mm)
579-665-12	ST46EZAB-10B	10	30
579-666-12	ST46EZAB-25B	25	45
579-667-12	ST46EZAB-50B	50	70
579-668-12	ST46EZAB-75B	75	90
579-669-12	ST46EZAB-80B	80	100
579-665-22	ST46EZAC-10B	10	30
579-666-22	ST46EZAC-25B	25	45
579-667-22	ST46EZAC-50B	50	70
579-668-22	ST46EZAC-75B	75	90
579-669-22	ST46EZAC-80B	80	100

Order No.	Code	Effective range L ₁ (mm)	Overall length L ₂ (mm)	L ₃ (mm)	L ₄ (mm)
579-665-13	ST46EZAB-10C	10	30	15	7.5
579-666-13	ST46EZAB-25C	25	45	25	10
579-667-13	ST46EZAB-50C	50	70	40	15
579-668-13	ST46EZAB-75C	75	90	60	15
579-669-13	ST46EZAB-80C	80	100	70	15
579-665-23	ST46EZAC-10C	10	30	15	7.5
579-666-23	ST46EZAC-25C	25	45	25	10
579-667-23	ST46EZAC-50C	50	70	40	15
579-668-23	ST46EZAC-75C	75	90	60	15
579-669-23	ST46EZAC-80C	80	100	70	15

- Effective range 100 to 3000mm

Unit: mm

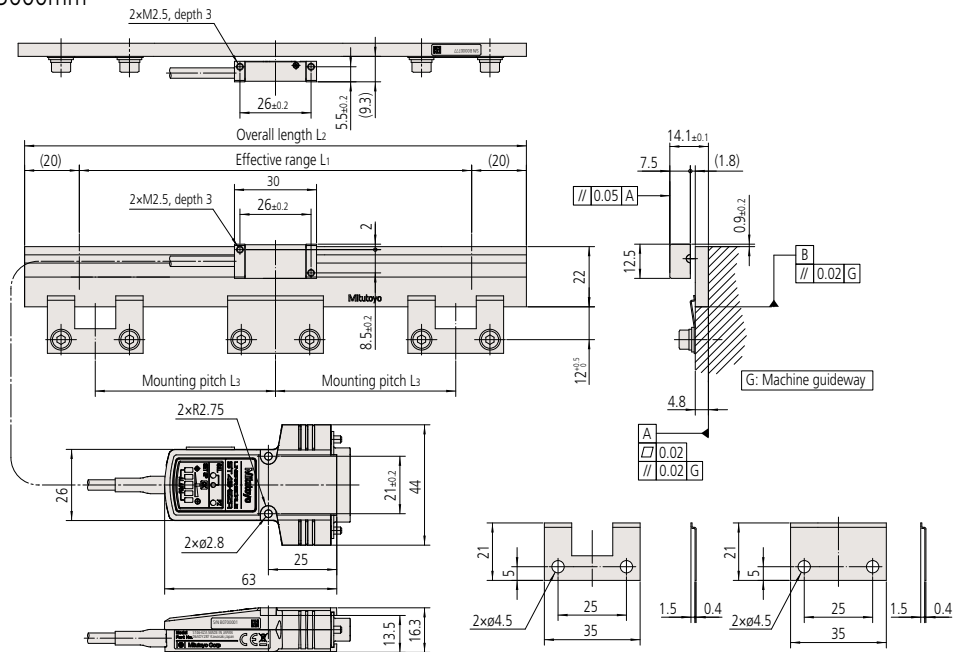

Dimensions of scale units

Order No.*	Code*	Effective range L ₁ (mm)	Overall length L ₂ (mm)	Scale fixing pitch L ₃ (mm)	Scale retaining spring A (pcs.)	Scale retaining spring B (pcs.)
579-670-□1	ST46EZA◇- 100A	100	140	50	1	2
579-671-□1	ST46EZA◇- 150A	150	190	75		2
579-672-□1	ST46EZA◇- 200A	200	240	100		2
579-673-□1	ST46EZA◇- 250A	250	290	60		4
579-674-□1	ST46EZA◇- 300A	300	340	75		4
579-675-□1	ST46EZA◇- 350A	350	390	85		4
579-676-□1	ST46EZA◇- 400A	400	440	100		4
579-677-□1	ST46EZA◇- 450A	450	490	75		6
579-678-□1	ST46EZA◇- 500A	500	540	80		6
579-679-□1	ST46EZA◇- 600A	600	640	100		6
579-680-□1	ST46EZA◇- 700A	700	740	85		8
579-681-□1	ST46EZA◇- 800A	800	840	100		8
579-682-□1	ST46EZA◇- 900A	900	940	90		10
579-683-□1	ST46EZA◇-1000A	1000	1040	100		10
579-684-□1	ST46EZA◇-1100A	1100	1140	90		12
579-685-□1	ST46EZA◇-1200A	1200	1240	100		12
579-686-□1	ST46EZA◇-1300A	1300	1340	130		10
579-687-□1	ST46EZA◇-1400A	1400	1440	100		14
579-688-□1	ST46EZA◇-1500A	1500	1540	125		12
579-689-□1	ST46EZA◇-1600A	1600	1640	100		16
579-690-□1	ST46EZA◇-1700A	1700	1740	120		14
579-691-□1	ST46EZA◇-1800A	1800	1840	100		18
579-692-□1	ST46EZA◇-2000A	2000	2040	100		20
579-693-□1	ST46EZA◇-2200A	2200	2240	100		22
579-694-□1	ST46EZA◇-2400A	2400	2440	100		24
579-695-□1	ST46EZA◇-2500A	2500	2540	95		26
579-696-□1	ST46EZA◇-2600A	2600	2640	100		26
579-697-□1	ST46EZA◇-2800A	2800	2840	100		28
579-698-□1	ST46EZA◇-3000A	3000	3040	100		30

* The above code numbers are for recommended items marked with ● symbol. If recommended specifications meet your requirements, please use these code numbers to order.

- ◇ → B (2-phase square wave signals + external reset input): □ → 1
- ◇ → C (2-phase square wave signals + 2-phase sinusoidal signals): □ → 2

Separate Type ST Series

Sinusoidal signal & Square-Wave Signal Output Scale Unit (Compact Type)

ST46-EZA Metal Tape Scale Type

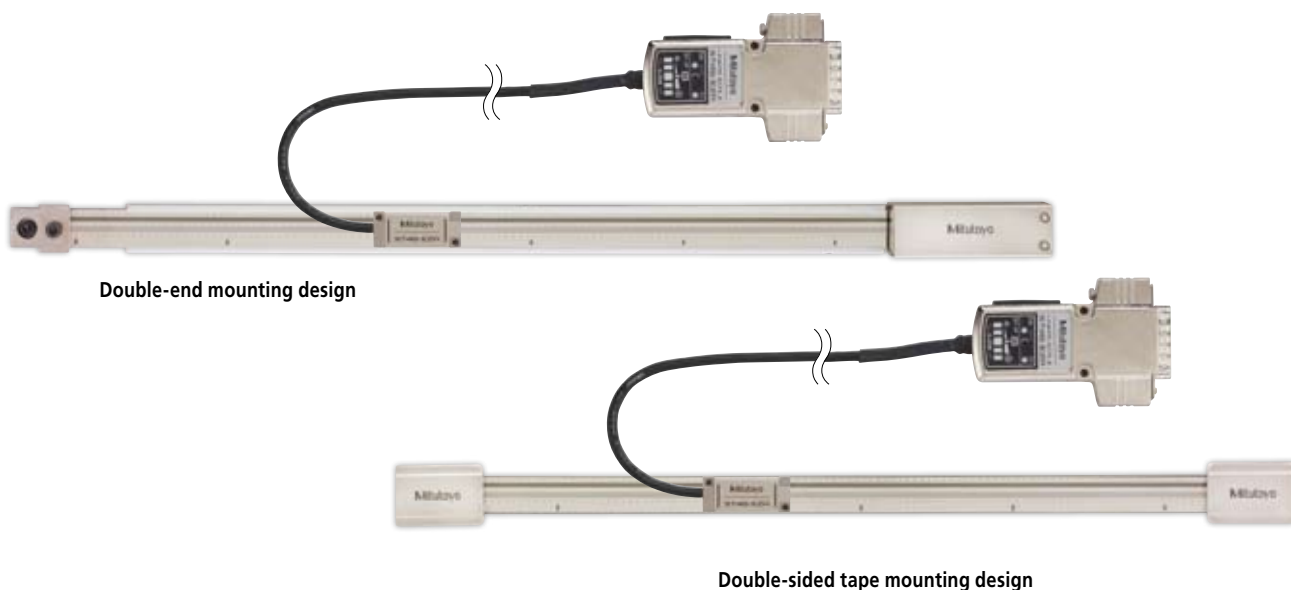

Features

- Includes an automatic adjusting function for the signal (EZA function) at the push of a button.
- Detector head mounting and signal adjustment possible without oscilloscope or PC.
- A setup indicator for checking signal strength is included.
- I/F circuit integrated in connector shell reduces volume to 60% compared to conventional interface.
- The thickness of the detector head is only 7.5 mm. The metal tape scale type has a mounting surface area of 12.5 by 9.325 mm, allowing use in applications where a space-saving design is important.

SPECIFICATIONS

Model	ST46-EZA
Detection method	Reflective photoelectric linear encoder
Scale type	Metal tape
Main scale grating pitch	20μm
Output signal	Type B: 2-phase square wave signals, reference point pulse, external reset input. Type C: 2-phase square wave signals, reference point pulse, 2-phase sinusoidal signals.
Effective range	10 to 3000mm
Accuracy (20°C)	Effective range 10 to 1000mm: ±5μm Effective range 1100 to 3000mm: ±5μm/m (The above accuracy applies to individual scales. For double-end mounting designs, perform point-to-point correction after ensuring the metal tape is tensioned correctly.)
Maximum response speed	2.6m/s (With sinusoidal signal amplitude of -3dB)
Scale reference point	50mm pitch, 10 to 80mm: Center point
Power supply voltage	5VDC±5%
Operating temperature/ humidity range	0 to 40°C, RH 20 to 80% (no condensation)
Storage temperature/ humidity range	-20 to 60°C, RH 20 to 80% (no condensation)

System Configuration

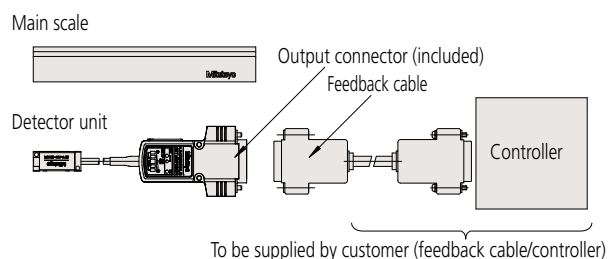

Output specification

- Connector pin assignment (Type B)

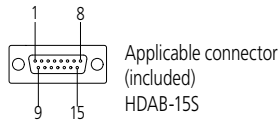

Pin No.	Signal	Pin No.	Signal
1, 2	0V (GND)	10	PA (main signal pulse_Normal phase)
3, 4	+5V (Vcc)	11	PA (main signal pulse_Reverse phase)
5	Reset input AL (anode)	12	PB (main signal pulse_Normal phase)
6	Reset input AL (cathode)	13	PB (main signal pulse_Reverse phase)
7	NC	14	PZ (reference point pulse_Reverse phase)
8	PZ (reference point pulse_Normal phase)	15	F. G
9	ALM (alarm)		

- Connector pin assignment (Type C)

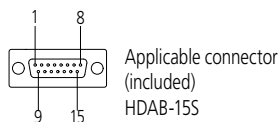

Pin No.	Signal	Pin No.	Signal
1, 2	0V (GND)	10	PA (main signal pulse_Normal phase)
3, 4	+5V (Vcc)	11	PA (main signal pulse_Reverse phase)
5	Phase A (sinusoidal signal)	12	PB (main signal pulse_Normal phase)
6	Phase B (sinusoidal signal)	13	PB (main signal pulse_Reverse phase)
7	Vref ($\approx V_{cc} / 2$)	14	PZ (reference point pulse_Reverse phase)
8	PZ (reference point pulse_Normal phase)	15	F. G
9	ALM (alarm)		

- Application program (Option, Part No.06AEF800)

Connector control unit has setup indicator

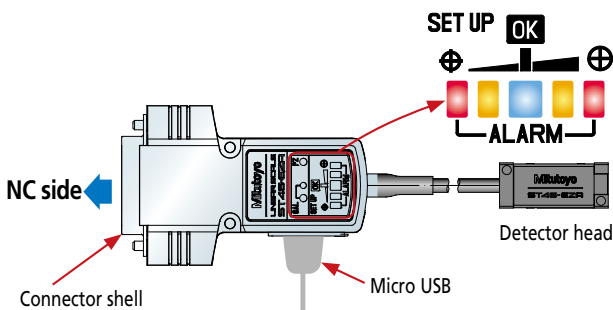

Output signal waveform and specification

- 2-phase square wave signals (Type B)

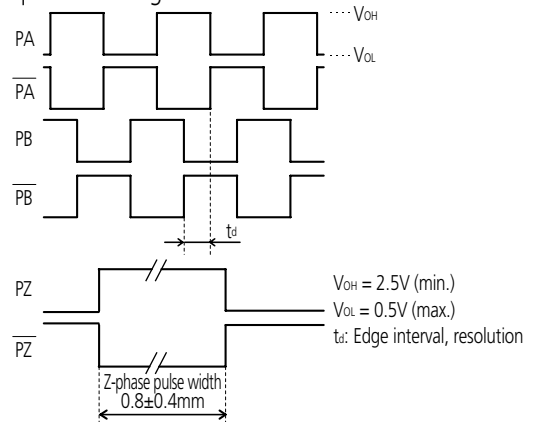

- 2-phase sinusoidal signals, 2-phase square wave signals (Type C)

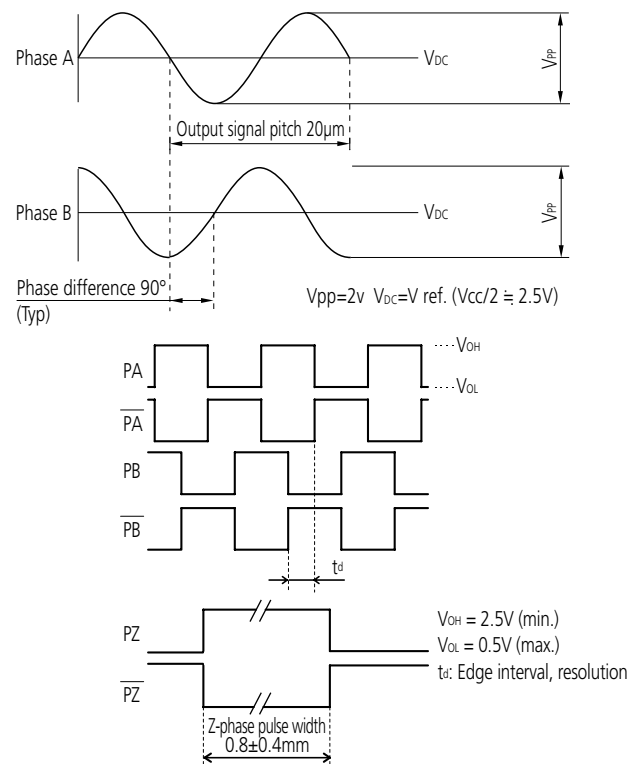

Specification Selection Method

(Metal Tape Scale Type)

How to read the code

ST46-EZA - -

Signal output

Code	Details
B	Square wave signal + external reset input
C	Sinusoidal signal + Square wave signal

Effective range

Code	Effective range (mm)	Code	Effective range (mm)	Code	Effective range (mm)
0010	10	0450	450	1600	1600
0025	25	0500	500	1700	1700
0050	50	0600	600	1800	1800
0075	75	0700	700	2000	2000
0080	80	0800	800	2200	2200
0100	100	0900	900	2400	2400
0150	150	1000	1000	2500	2500
0200	200	1100	1100	2600	2600
0250	250	1200	1200	2800	2800
0300	300	1300	1300	3000	3000
0350	350	1400	1400		
0400	400	1500	1500		

Note: For the standard specification, the indicated effective range depends on the product code.

Example of standard specification

Effective range 10mm: **ST46EZA**-**0010**

Effective range 250mm: **ST46EZA**-**0250**

Reference point/ Scale shape

Code	Details (Effective range)	Details - Cross-section (Effective range)
D	50mm pitch (500 to 3000mm)	Metal Tape Scale double-end mounting: t0.2 x w13 (500 to 3000mm)
E	Center point (10 to 80mm) 50mm pitch (100 to 3000mm)	Metal Tape Scale Double-sided tape mounting: t0.2 x w13 (10 to 3000mm)
Z	Special position specification	Special shape

Resolution / Minimum edge interval

Code	Resolution	Minimum edge interval	Maximum response speed
A	0.05 μ m	100 ns	450 mm/s
B		200 ns	225 mm/s
C		400 ns	112 mm/s
D		800 ns	56 mm/s
E	0.1 μ m	100 ns	900 mm/s
F		200 ns	450 mm/s
G		400 ns	225 mm/s
H		800 ns	112 mm/s
J	0.5 μ m	100 ns	2600 mm/s
K		200 ns	2250 mm/s
L		400 ns	1125 mm/s
M		800 ns	562 mm/s
N	1 μ m	100 ns	2600 mm/s
P		200 ns	2600 mm/s
Q		400 ns	2250 mm/s
R		800 ns	1125 mm/s
S	5 μ m	100 ns	2600 mm/s
T		200 ns	2600 mm/s
U		400 ns	2600 mm/s
V		800 ns	2600 mm/s

- There is an extensive selection of specifications for the ST46-EZA.
 - Choose the appropriate numbers and letters below according to specification required.
- If standard specifications (recommended items marked with ● symbol below) meet your requirements, please order using the code numbers shown on pages 19 - 20.

Special codes

Code	Details
●None	Standard selection specification
Z	Special specification

Head cable length

Code	Length
●A	1m (standard)
B	0.5m
C	2m
Z	Special length specification (max. 2.5m)

Alarm output

Code	Details
●S	Alarm signal
H	High impedance

Direction

Code	Details
●1	Normal
2	Reverse

When the direction is normal, the sinusoidal signal, the 2-phase square wave output signal (Phase A, Phase B) and the reference point signal waveform are as shown below.

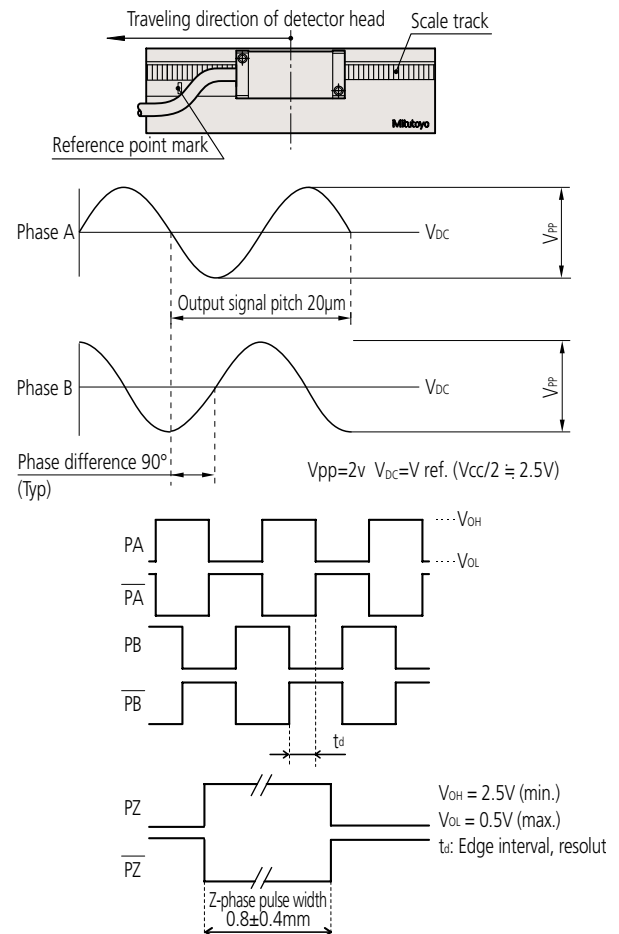

(Metal Tape Scale Type)

- Double-end mounting design (effective range 500 to 1000mm)

Unit: mm

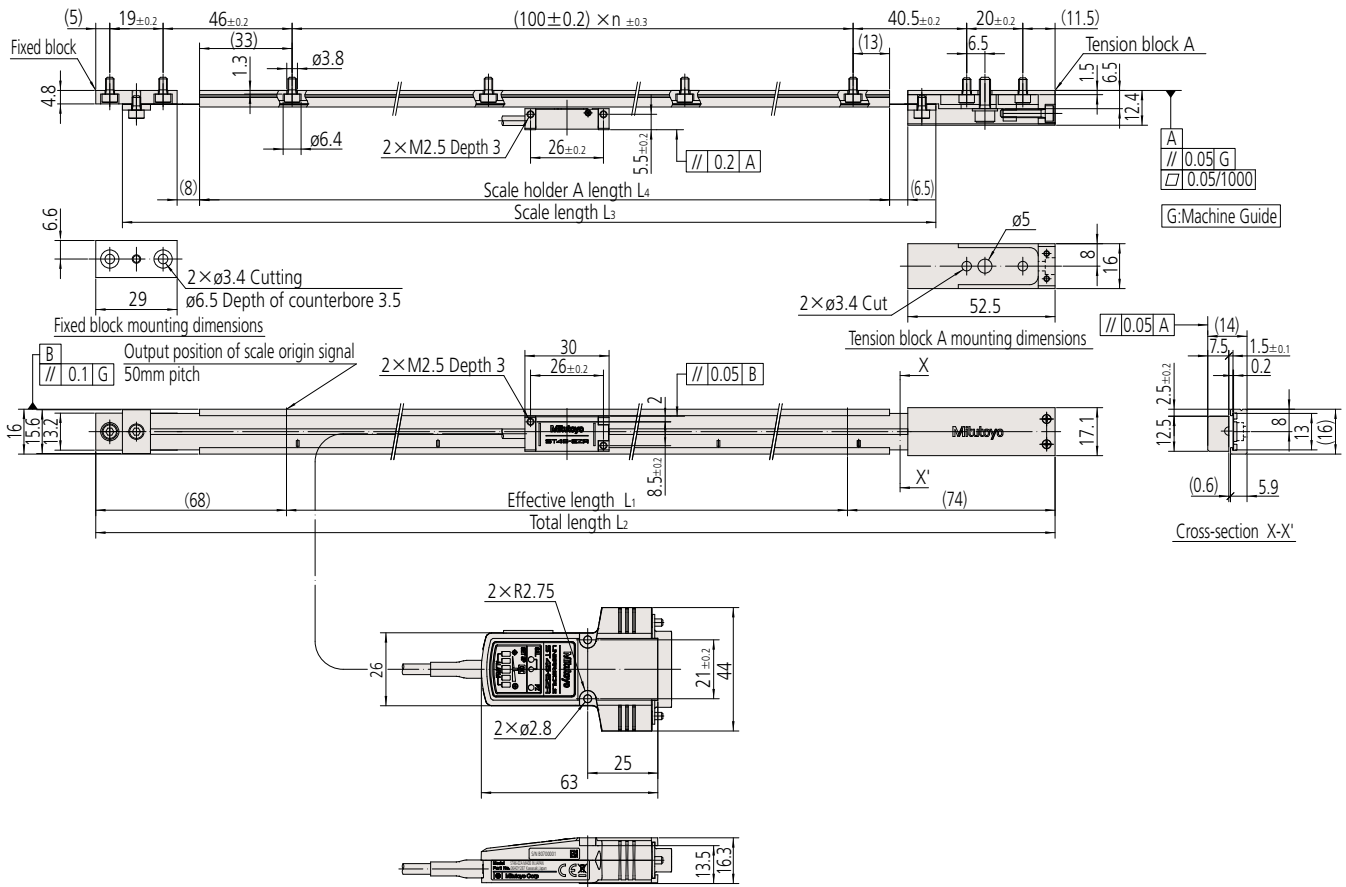

Dimensions of scale units

Order No.	Code	Effective range L_1 (mm)	Scale Overall length L_2 (mm)	Scale length L_3 (mm)	Scale holder A length L_4 (mm)	n
579-678-□4	ST46EZA◇- 500D	500	642	590	546	5
579-679-□4	ST46EZA◇- 600D	600	742	690	646	6
579-680-□4	ST46EZA◇- 700D	700	842	790	746	7
579-681-□4	ST46EZA◇- 800D	800	942	890	846	8
579-682-□4	ST46EZA◇- 900D	900	1042	990	946	9
579-683-□4	ST46EZA◇-1000D	1000	1142	1090	1046	10

* The above code numbers are for recommended items marked with symbol. If recommended specifications meet your requirements, please use these code numbers to order.

◇ → B (2-phase square wave signals + external reset input): □ → 1

◇ → C (2-phase square wave signals + 2-phase sinusoidal signals): □ → 2

- Double-end mounting design (effective range 1100 to 3000mm)

Unit: mm

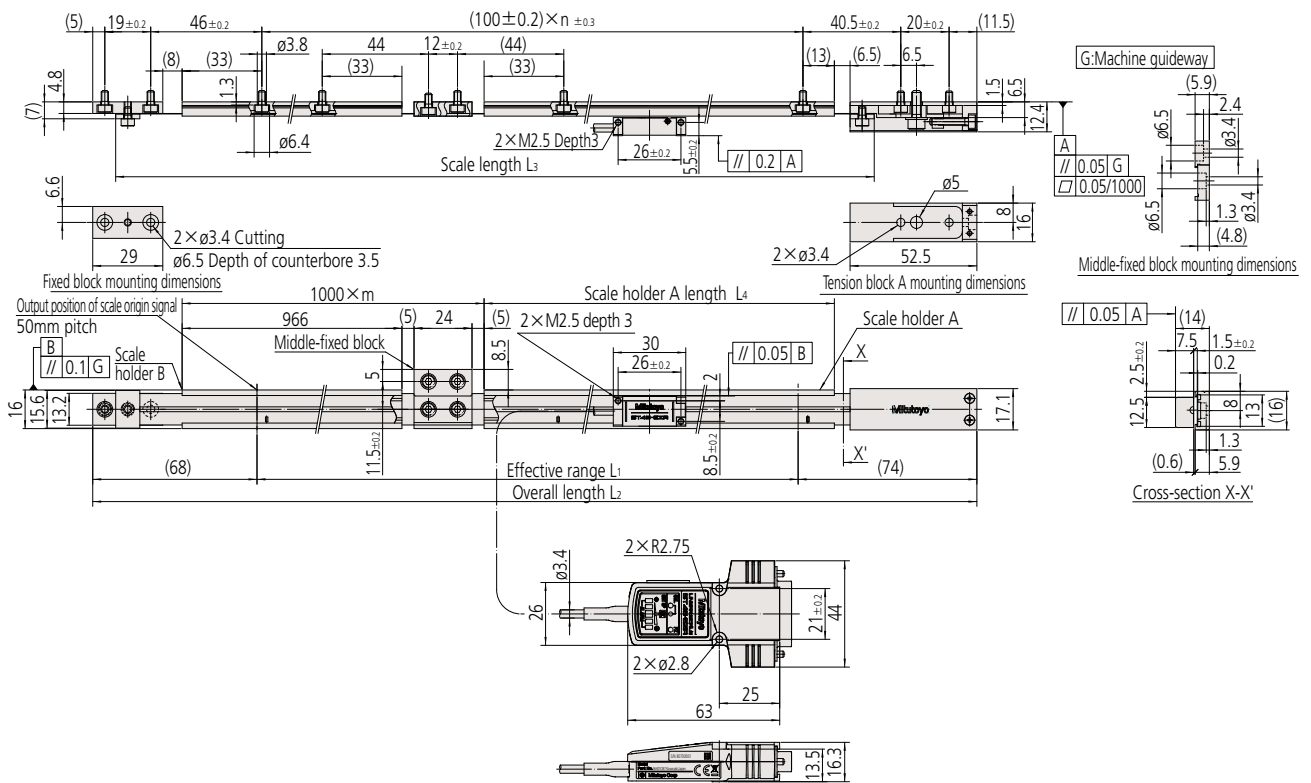

Dimensions of scale units

Order No.	Code	Effective range L ₁ (mm)	Scale Overall length L ₂ (mm)	Scale length L ₃ (mm)	Scale holder A length L ₄ (mm)	m	n
579-684-□4	ST46EZA◇-1100D	1100	1242	1190	146	1	11
579-685-□4	ST46EZA◇-1200D	1200	1342	1290	246	1	12
579-686-□4	ST46EZA◇-1300D	1300	1442	1390	346	1	13
579-687-□4	ST46EZA◇-1400D	1400	1542	1490	446	1	14
579-688-□4	ST46EZA◇-1500D	1500	1642	1590	546	1	15
579-689-□4	ST46EZA◇-1600D	1600	1742	1690	646	1	16
579-690-□4	ST46EZA◇-1700D	1700	1842	1790	746	1	17
579-691-□4	ST46EZA◇-1800D	1800	1942	1890	846	1	18
579-692-□4	ST46EZA◇-2000D	2000	2142	2090	1046	1	20
579-693-□4	ST46EZA◇-2200D	2200	2342	2290	246	2	22
579-694-□4	ST46EZA◇-2400D	2400	2542	2490	446	2	24
579-695-□4	ST46EZA◇-2500D	2500	2642	2590	546	2	25
579-696-□4	ST46EZA◇-2600D	2600	2742	2690	646	2	26
579-697-□4	ST46EZA◇-2800D	2800	2942	2890	846	2	28
579-698-□4	ST46EZA◇-3000D	3000	3142	3090	1046	2	30

* The above code numbers are for recommended items marked with symbol. If recommended specifications meet your requirements, please use these code numbers to order.

- ◇ → B (2-phase square wave signals + external reset input): □ → 1
- ◇ → C (2-phase square wave signals + 2-phase sinusoidal signals): □ → 2

• Double-sided tape mounting design

Unit: mm

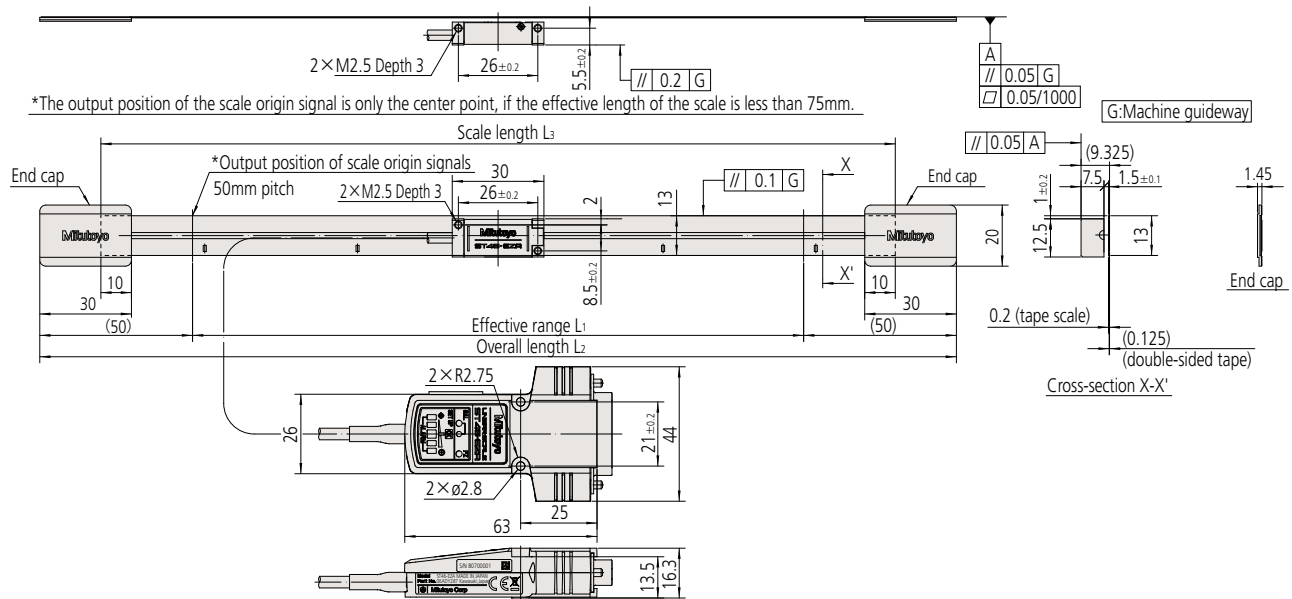

Separate Type ST Series
ST46-EZA

Dimensions of scale units

Order No.	Code	Effective range L ₁ (mm)	Scale Overall length L ₂ (mm)	Scale length L ₃ (mm)
579-665-□5	ST46EZA◇- 10E	10	110	70
579-666-□5	ST46EZA◇- 25E	25	125	85
579-667-□5	ST46EZA◇- 50E	50	150	110
579-668-□5	ST46EZA◇- 75E	75	175	135
579-670-□5	ST46EZA◇- 100E	100	200	160
579-671-□5	ST46EZA◇- 150E	150	250	210
579-672-□5	ST46EZA◇- 200E	200	300	260
579-673-□5	ST46EZA◇- 250E	250	350	310
579-674-□5	ST46EZA◇- 300E	300	400	360
579-675-□5	ST46EZA◇- 350E	350	450	410
579-676-□5	ST46EZA◇- 400E	400	500	460
579-677-□5	ST46EZA◇- 450E	450	550	510
579-678-□5	ST46EZA◇- 500E	500	600	560
579-679-□5	ST46EZA◇- 600E	600	700	660
579-680-□5	ST46EZA◇- 700E	700	800	760
579-681-□5	ST46EZA◇- 800E	800	900	860
579-682-□5	ST46EZA◇- 900E	900	1000	960
579-683-□5	ST46EZA◇-1000E	1000	1100	1060
579-684-□5	ST46EZA◇-1100E	1100	1200	1160
579-685-□5	ST46EZA◇-1200E	1200	1300	1260
579-686-□5	ST46EZA◇-1300E	1300	1400	1360
579-687-□5	ST46EZA◇-1400E	1400	1500	1460
579-688-□5	ST46EZA◇-1500E	1500	1600	1560
579-689-□5	ST46EZA◇-1600E	1600	1700	1660
579-690-□5	ST46EZA◇-1700E	1700	1800	1760
579-691-□5	ST46EZA◇-1800E	1800	1900	1860
579-692-□5	ST46EZA◇-2000E	2000	2100	2060
579-693-□5	ST46EZA◇-2200E	2200	2300	2260
579-694-□5	ST46EZA◇-2400E	2400	2500	2460
579-695-□5	ST46EZA◇-2500E	2500	2600	2560
579-696-□5	ST46EZA◇-2600E	2600	2700	2660
579-697-□5	ST46EZA◇-2800E	2800	2900	2860
579-698-□5	ST46EZA◇-3000E	3000	3100	3060

* The above code numbers are for recommended items marked with symbol. If recommended specifications meet your requirements, please use these code numbers to order.
 ◇ → B (2-phase square wave signals + external reset input): □ → 1
 ◇ → C (2-phase square wave signals + 2-phase sinusoidal signals): □ → 2



Assembly Type AT Series

1Vpp Differential Signal Output Type Scale Unit

AT402E



Features

- Ideal for machine tools for heavy cutting as well as linear motors.
- Has multi-point elastic fixing for excellent vibration resistance (200m/s^2), shock resistance (400m/s^2), and temperature characteristics.
- The adoption of the Absolute Interval Code has enabled a simplified, low-cost ABS system.

Specifications

Item	Code	AT402E-A Type	AT402E-B Type	AT402E-C Type
Cable configuration		3m single wire	3m European CNC manufacturers' specification	3m FANUC LTD. specification
Detection method		Photoelectric linear encoder		
Base position of elongation due to temperature changes		Midpoint of the screws used for rigid fixing near the midpoint of the effective range.		
Effective range		140 to 3040mm		
Output signal		Signal: 1Vpp differential Sinusoidal signal, differential reference point pulse: Absolute Interval Code compatible		
Signal output pitch		20 μm		
Maximum response speed		120m/min (with Sinusoidal signal amplitude of -3db)		
Accuracy (20°C)		Effective range 140 to 540mm : $\pm 2\mu\text{m}$ Effective range 640 to 940mm : $\pm 3\mu\text{m}$ Effective range 1040 to 3040mm : $\pm 3\mu\text{m/m}$		
Thermal expansion coefficient		$\approx 8 \times 10^{-6} / \text{K}$		
Operating temperature/humidity		0 to 45°C 20 to 80% RH (no condensation)		
Storage temperature/humidity		-20 to 70°C 20 to 80% RH (no condensation)		
Vibration resistance		200 m/s^2 (55 to 2000Hz)		
Shock resistance		400 m/s^2 (half-sine 11ms)		
Power supply voltage		5VDC $\pm 5\%$		
Maximum current consumption		120mA		
Maximum sliding force		4N		
Air supply hole		With air supply hole (end of scale frame/detector head)		

Note 1: For details regarding the applicable system, please consult with the individual manufacturer.

Cable configuration

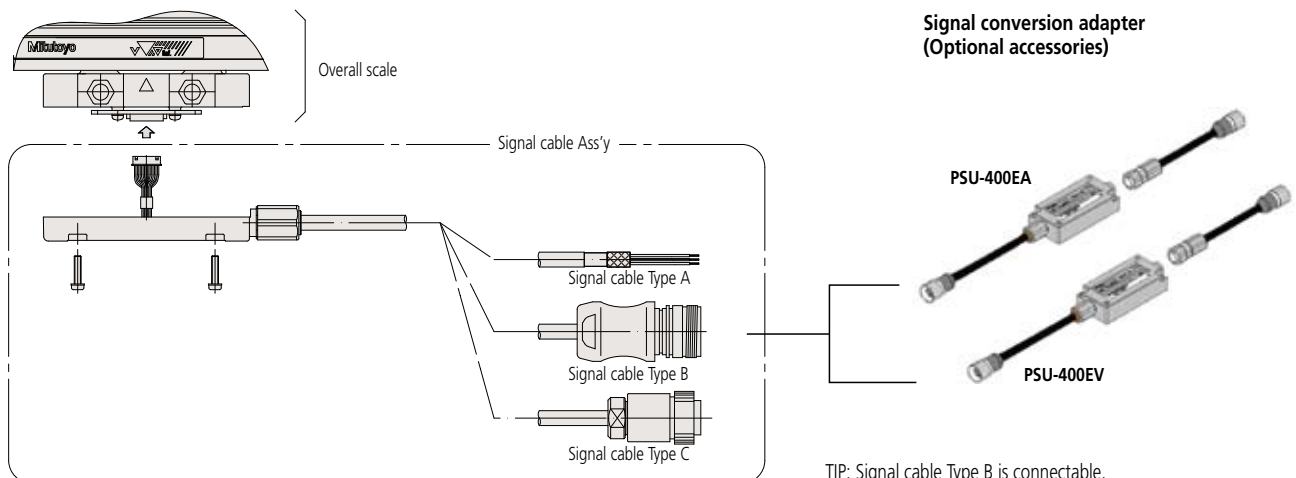

Interface Unit (Optional accessories) Signal Conversion Adapter PSU-400E



Features

- The PSU-400E series interface unit converts the 1Vp-p differential signal output by AT402E, so that NC feedback systems or measurement control devices can be used with linear scales in order to achieve highly accurate positioning.
- PSU-400EA interface unit converts the 1Vp-p differential signal output by AT402E to the 11 μ A differential signal.
- PSU-400EV interface unit splits the 1Vp-p differential signal output by AT402E into a minimum of 20 and a maximum of 4000 divisions, and converts the signal to a square wave.

Specifications

Order No. Items	539-008 PSU-400EA	539-009 PSU-400EV
Input signal	1Vpp differential Sinusoidal signal (AT402E)	
Output signal	11 μ A sine wave signal	TTL signal (RS422)
Output signal: Division number (Resolution)	—	TTL X5 (1 μ m), TTL X10 (0.5 μ m), TTL X20 (0.25 μ m), TTL X25 (0.2 μ m), TTL X50 (0.1 μ m), TTL X100 (0.05 μ m), TTL X250 (0.1 μ m), TTL X500 (0.01 μ m), TTL X1000 (0.005 μ m)
Minimum edge intervals	—	62.5, 125, 250, 500, 1000, 2000 [ns]
Maximum current consumption	60mA	130mA
Power supply	DC5V \pm 5%	
Storage temperature	-20 to 70°C 20 to 80%RH	
Operating temperature	0 to 50°C 20 to 80%RH	
External dimension	80(W) \times 40(D) \times 20(H)	
Status LED	Simple error display (without error output)	Error display (with error output)
Response speed	120m/min (100kHz)	It depends on number of interpolation and minimum edge intervals (Max: 100kHz)

TIP: Signal cable Type B is connectable.

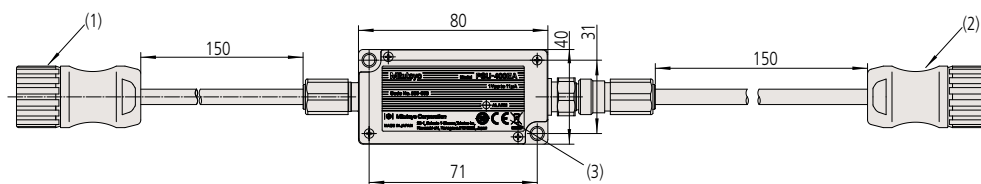

No.	Name	
(1)	INPUT connector	Connector for connecting with Linear Scale AT402E
(2)	OUTPUT connector	Connector for connecting with external device
(3)	ALM lamp	Lights red when alarming (Normally lights green)

Pin assignment

(1) Signal cable A (single wire specification)

Wire color	Signal	Wire color	Signal
White	+5V	Yellow	Phase XB
Black	GND	Green	Phase Z
Brown	Phase A	Blue	Phase XZ
Red	Phase XA	Shield	FG
Orange	Phase B		

Note 1: Ground the shield to the earth bar

(2) Signal cable B (European CNC manufacturer's specification)

12-pin Type Connector without locking ring

Pin	Signal	Pin	Signal
2,12	+5V	1	Phase XB
10,11	GND	3	Phase Z
5	Phase A	4	Phase XZ
6	Phase XA	Shell	FG
8	Phase B	7,9	Not used

(3) Signal cable C (FANUC LTD. specification)

12-pin Type Connector

Pin	Signal	Pin	Signal
1,2	+5V	8	Phase XB
3,4	GND	9	Phase Z
5	Phase A	10	Phase XZ
6	Phase XA	11, shell	FG
7	Phase B	12	Not used

Note 1: Connector used: RM15WTP-12P

Note 2: Applicable connector: RM15WTR-12S
(Hirose Electric or equivalent product)

(4) When connecting with PSU-400EA

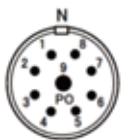

Pin	Cable color	Signal
1	White	IA+
2	Black	IA-
3	Brown	+5V
4	Red	GND
5	Orange	IB+
6	Yellow	IB-
7	Green	IZ+
8	Blue	IZ-
9	Pink	F.G. (shell)

(5) When connecting with PSU-400EV

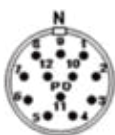

Pin	Cable color	Signal
1	Blue	PB
2	Brown	+5V
3	Purple	PZ
4	Grey	PZ̄
5	Orange	PA
6	Yellow	PĀ
7	Pink	ĀL
8	Green	PB
9	-	Not used
10	Red	GND
11	Black	GND
12	White	+5V

Output signal waveform

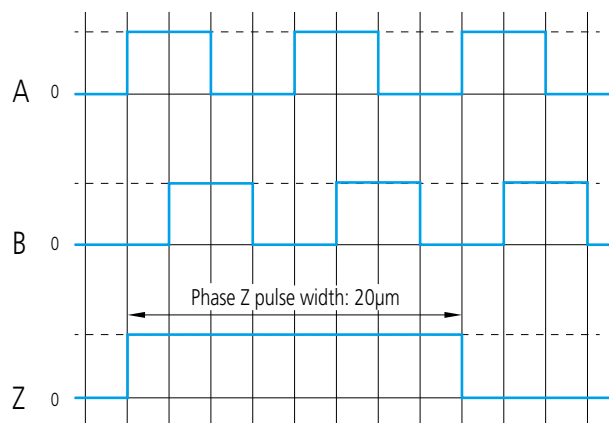
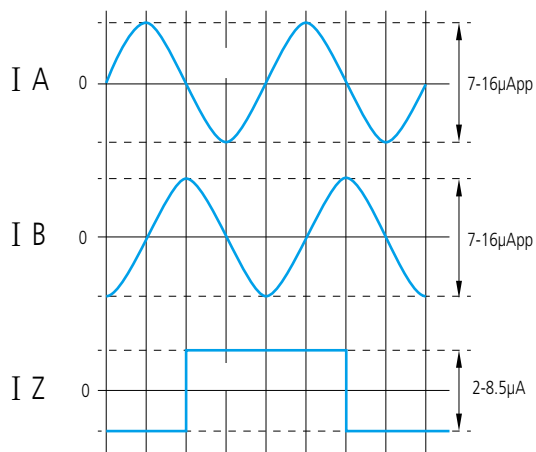
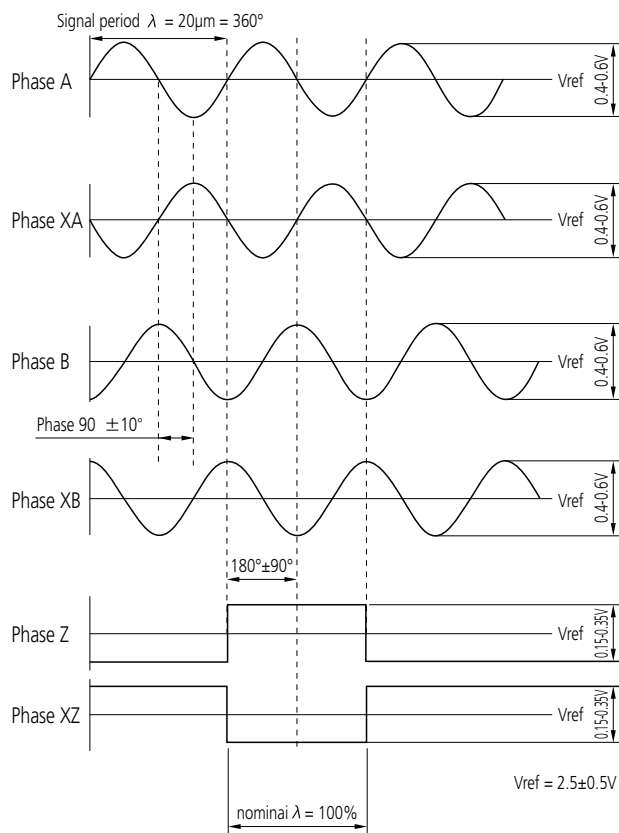

AT402E scale unit mounting dimensions

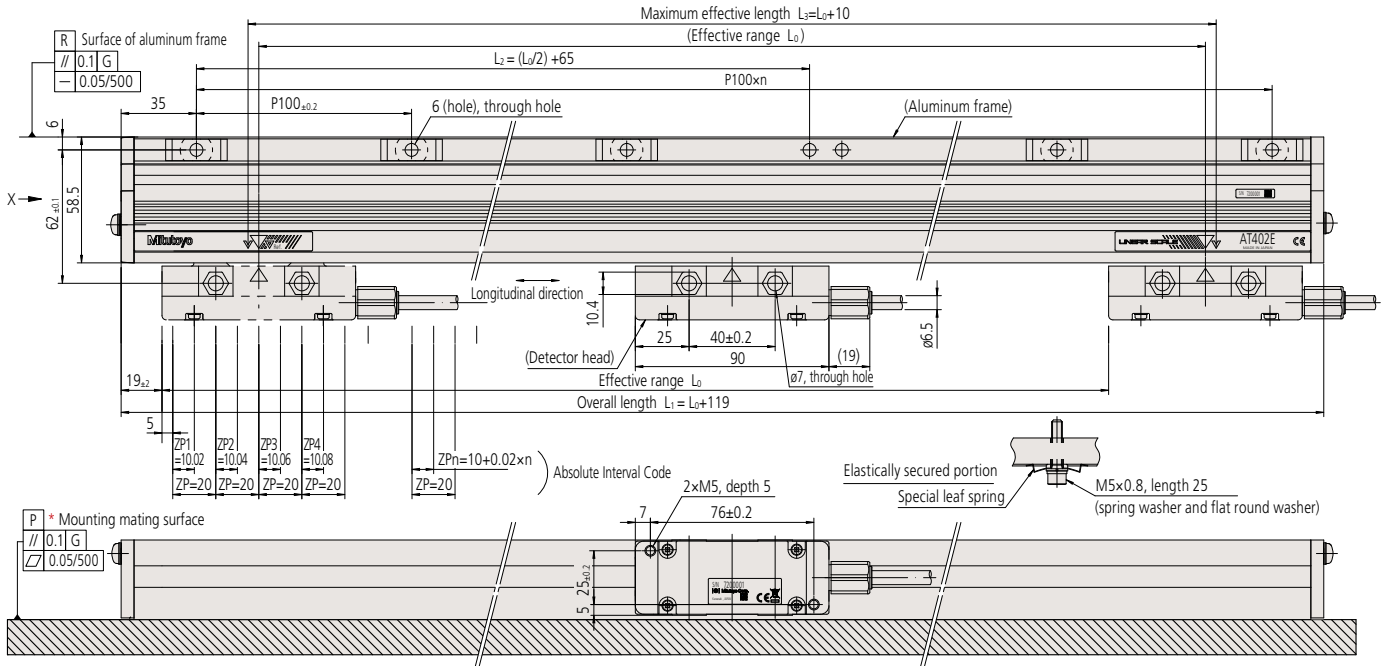

[Notes]

1. G indicates the machine guideway.
2. P indicates the mating surface for mounting the aluminum frame. S indicates the mating surface for mounting the detector head.
3. Q and R indicate the datum surfaces for mounting this linear scale.

Absolute Interval Code

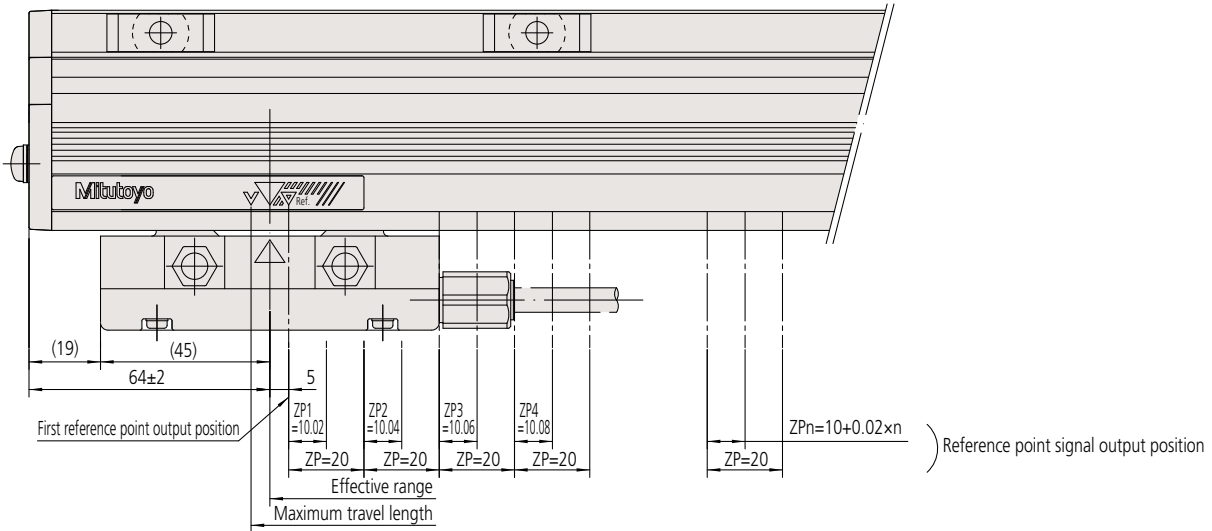

View from X direction

Mounting example 1

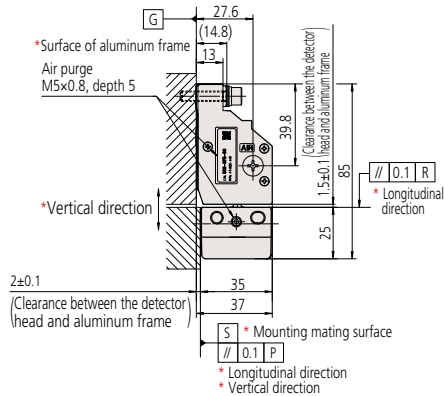

Mounting example 2

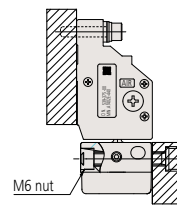

Mounting example 3

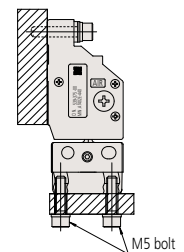

Dimensions of scale units

Code	Effective range L ₀ (mm)	Overall length L ₁ (mm)	L ₂ (mm)	Maximum travel length L ₃ (mm)	n (pcs)
AT402E-140	140	259	135	150	2
AT402E-240	240	359	185	250	3
AT402E-340	340	459	235	350	4
AT402E-440	440	559	285	450	5
AT402E-540	540	659	335	550	6
AT402E-640	640	759	358	650	7
AT402E-740	740	859	435	750	8
AT402E-840	840	985	485	850	9
AT402E-940	940	1059	535	950	10
AT402E-1040	1040	1159	585	1050	11
AT402E-1140	1140	1259	635	1150	12
AT402E-1240	1240	1359	685	1250	13
AT402E-1340	1340	1459	735	1350	14
AT402E-1440	1440	1559	785	1450	15
AT402E-1540	1540	1659	835	1550	16
AT402E-1640	1640	1759	885	1650	17
AT402E-1740	1740	1859	935	1750	18
AT402E-1840	1840	1959	985	1850	19
AT402E-2040	2040	2159	1085	2050	21
AT402E-2240	2240	2359	1185	2250	23
AT402E-2440	2440	2559	1285	2450	25
AT402E-2640	2640	2759	1385	2650	27
AT402E-2840	2840	2959	1485	2850	29
AT402E-3040	3040	3159	1585	3050	31

Codes and Order Numbers

Code	Scale unit + single wire cable 3m (A Type)	Scale unit + cable with European CNC manufacturer's connector 3m (B Type)	Scale unit + Cable with FANUC LTD. connector 3m (C Type)
	Order No.	Order No.	Order No.
AT402E-140	539-371-01	539-371-02	539-371-03
AT402E-240	539-373-01	539-373-02	539-373-03
AT402E-340	539-374-01	539-374-02	539-374-03
AT402E-440	539-375-01	539-375-02	539-375-03
AT402E-540	539-376-01	539-376-02	539-376-03
AT402E-640	539-377-01	539-377-02	539-377-03
AT402E-740	539-378-01	539-378-02	539-378-03
AT402E-840	539-379-01	539-379-02	539-379-03
AT402E-940	539-380-01	539-380-02	539-380-03
AT402E-1040	539-381-01	539-381-02	539-381-03
AT402E-1140	539-382-01	539-382-02	539-382-03
AT402E-1240	539-383-01	539-383-02	539-383-03
AT402E-1340	539-384-01	539-384-02	539-384-03
AT402E-1440	539-385-01	539-385-02	539-385-03
AT402E-1540	539-386-01	539-386-02	539-386-03
AT402E-1640	539-387-01	539-387-02	539-387-03
AT402E-1740	539-388-01	539-388-02	539-388-03
AT402E-1840	539-389-01	539-389-02	539-389-03
AT402E-2040	539-390-01	539-390-02	539-390-03
AT402E-2240	539-391-01	539-391-02	539-391-03
AT402E-2440	539-392-01	539-392-02	539-392-03
AT402E-2640	539-393-01	539-393-02	539-393-03
AT402E-2840	539-394-01	539-394-02	539-394-03
AT402E-3040	539-395-01	539-395-02	539-395-03

Assembly Type AT Series

Square-Wave Signal Output Type Scale Unit (Slim/High-speed types)

AT211

Mounting method: Multi-point fixing (excellent vibration and shock resistance)

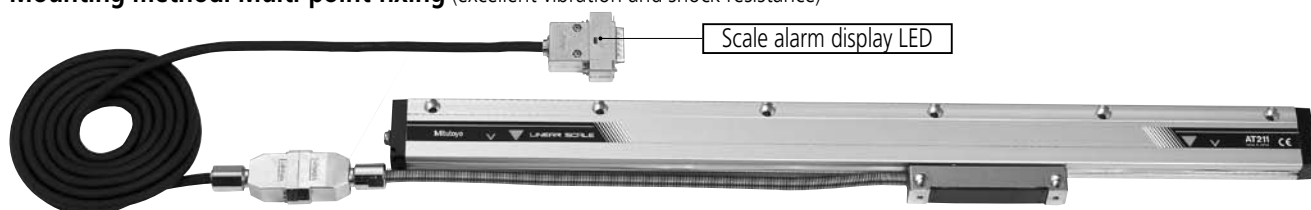

Mounting method: Double-end fixing (space-saving type)



Features

- This is a slim, sealed scale that can be directly connected to the control unit.
- High speed response up to 120m/min, making it compatible with a wide range of resolutions from 0.1 to 5 μ m.
- The multi-point fixing type has excellent vibration resistance.
- Scale alarm display makes for easy maintenance.
- Wide range of specifications enables easy choice to best suit your application.

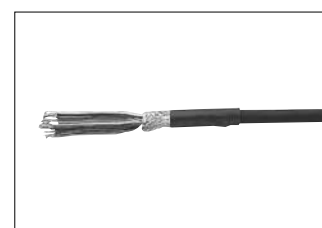

Single head cable type (no connector)

Specifications

Item	Code	AT211
Effective range (L _o)		100, 150, 200, 250, 300, 350, 400, 450, 500, 600, 700, 750, 800, 900, 1000, 1100, 1200, 1300, 1400, 1500 mm
Scale reference point		50mm pitch, center point, left end, right end (fixed when shipped)
Accuracy (20°C)		(3+3L _o /1000) μ m (For L _o 500mm, we can also fabricate a high-accuracy type: (2+2L _o /1000) μ m) L _o : Effective range (mm)
Vibration resistance		200 m/s ² (Conditions: 55 to 2000Hz) (Multi-point fixing type)
Shock resistance		250 m/s ² (Conditions: half-sine, 11ms) (Multi-point fixing type)
Air supply hole		With air supply hole (Multi-point fixing type)
Output signal	Type	PA/P \bar{A} , PB/P \bar{B} , PZ/P \bar{Z}
	Electrical specifications	Conforms to RS422
Main scale grating pitch		20 μ m
Minimum resolution		0.1, 0.2, 0.5, 1, 2.5, 5 μ m (fixed when shipped)
Minimum edge interval		125, 250, 333, 500, 1000ns (fixed when shipped)
Maximum response speed		5.4 to 120 m/min (Determined by minimum resolution and minimum edge interval)
Power supply voltage		5VDC \pm 5%
Maximum current consumption		200 mA
Sliding force		5N max.
Operating temperature		0 to 45°C
Storage temperature		-20 to 70°C
Operating/storage humidity		20 to 80%RH (no condensation)
Direction switching		Standard/Reverse (set when shipped)
Alarm function	Alarm detection	Over-speed, scale signal error
	Alarm output	Output for PA/P \bar{A} , PB/P \bar{B} , and PZ/P \bar{Z} are all high-impedance
	Alarm display	Red LED on NC side connector of signal cable turns on (this does not include single head cable types)

Mounting dimensions for multi-point fixing type

Unit: mm

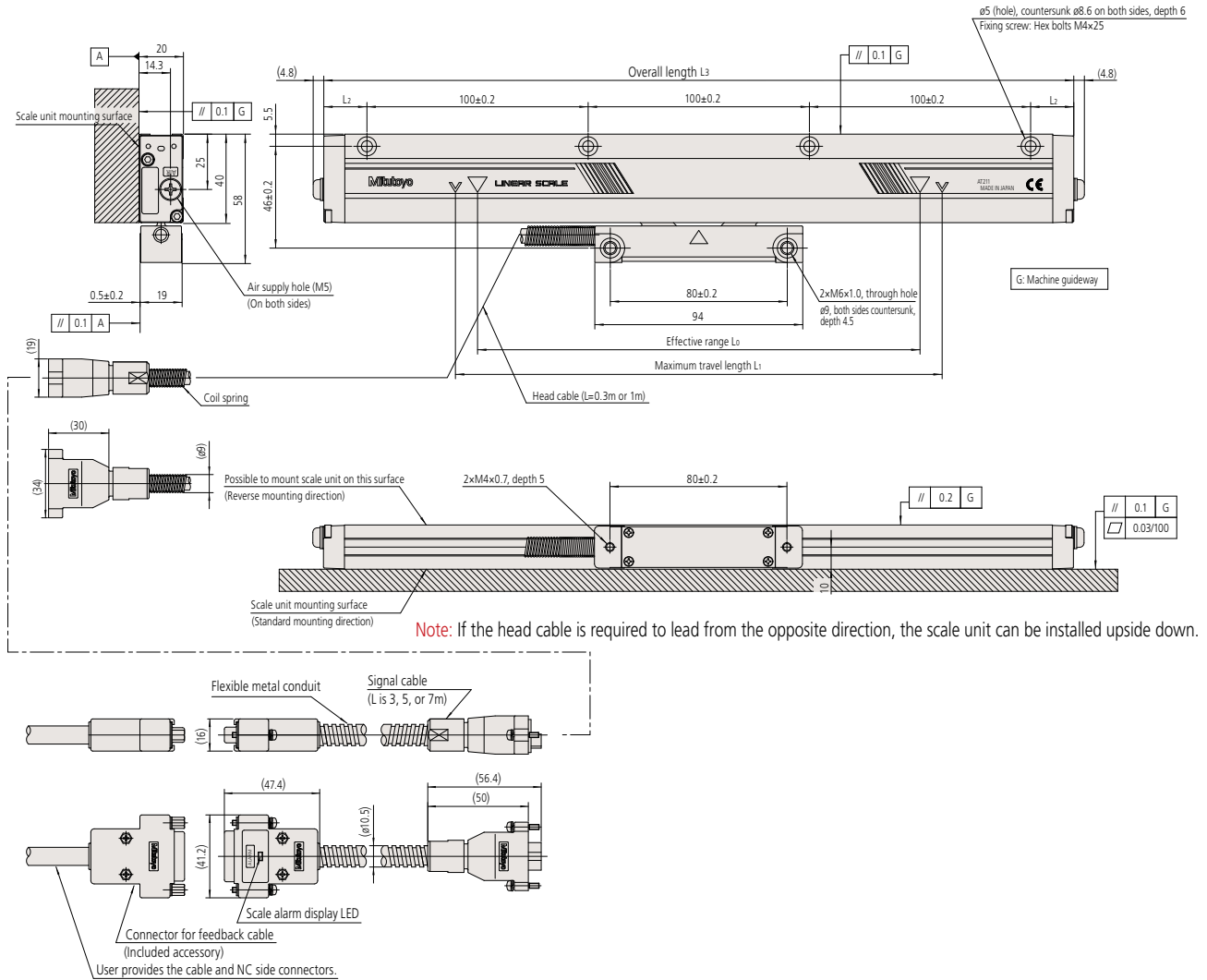

Mounting dimensions for multi-point fixing type

Scale unit	Effective range L_0 (mm)	Maximum travel length L_1 (mm)	End surface dimensions L_2 (mm)	Overall length L_3 (mm)	No. of mounting holes on scale unit (pcs)
AT211- 100A	100	120	19.5	239	3
AT211- 150A	150	170	44.5	289	3
AT211- 200A	200	220	19.5	339	4
AT211- 250A	250	270	44.5	389	4
AT211- 300A	300	330	24.5	449	5
AT211- 350A	350	380	49.5	499	5
AT211- 400A	400	430	24.5	549	6
AT211- 450A	450	480	49.5	599	6
AT211- 500A	500	540	29.5	659	7
AT211- 600A	600	640	29.5	759	8
AT211- 700A	700	740	29.5	859	9
AT211- 750A	750	780	49.5	899	9
AT211- 800A	800	840	29.5	959	10
AT211- 900A	900	940	29.5	1059	11
AT211-1000A	1000	1040	29.5	1159	12
AT211-1100A	1100	1140	29.5	1259	13
AT211-1200A	1200	1240	29.5	1359	14
AT211-1300A	1300	1340	29.5	1459	15
AT211-1400A	1400	1440	29.5	1559	16
AT211-1500A	1500	1540	29.5	1659	17

Mounting dimensions for double-end fixing type

Unit: mm

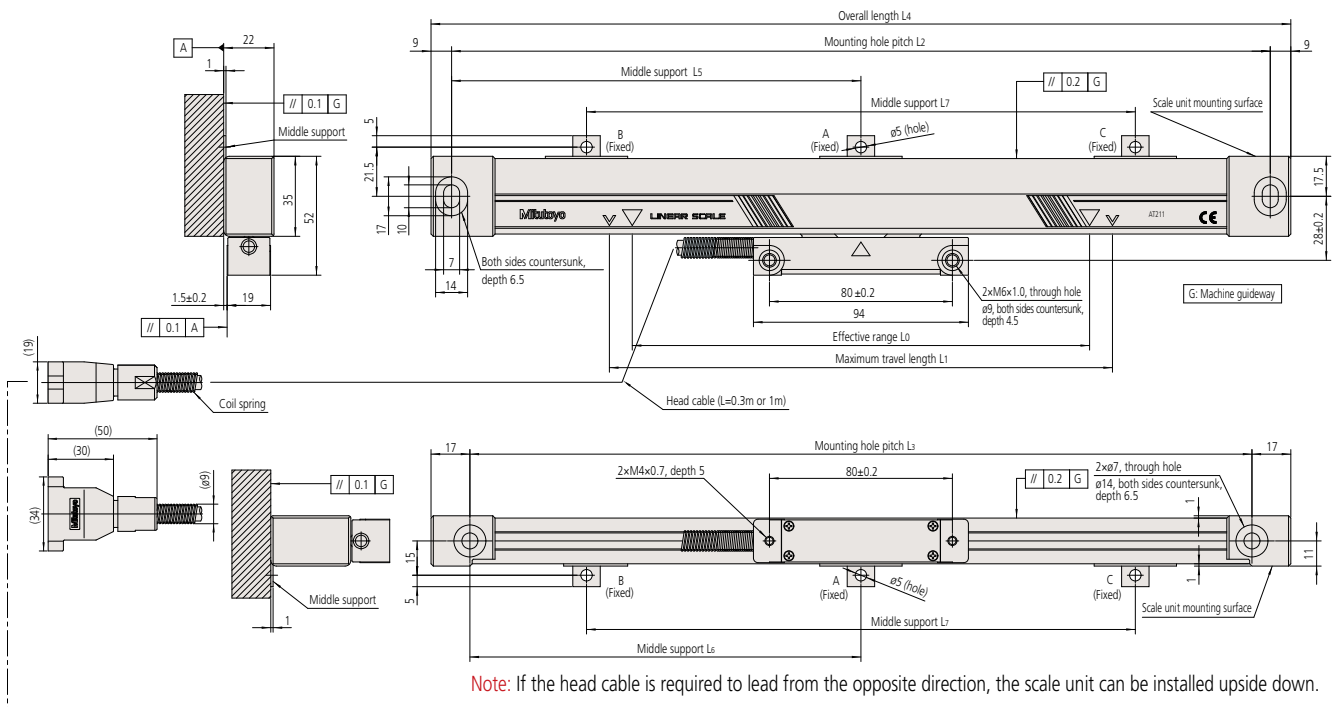

Note: If the head cable is required to lead from the opposite direction, the scale unit can be installed upside down.

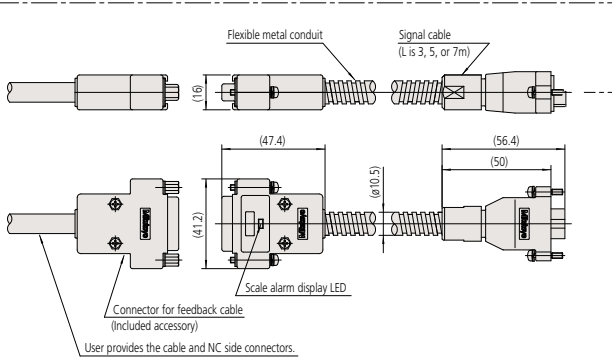

Mounting dimensions for double-end fixing type

Scale unit	Effective range L ₀ (mm)	Maximum travel length L ₁ (mm)	Mounting hole pitch (mm)		Overall length L ₄ (mm)	Middle support (mm)		
			L ₂ (mm)	L ₃ (mm)		L ₅	L ₆	L ₇
AT211- 100B	100	120	258	242	276			
AT211- 150B	150	170	308	292	326			
AT211- 200B	200	220	358	342	376			
AT211- 250B	250	270	408	392	426			
AT211- 300B	300	330	468	452	486			
AT211- 350B	350	380	518	502	536			
AT211- 400B	400	430	568	552	586			
AT211- 450B	450	480	618	602	636			
AT211- 500B	500	540	678	662	696	339	331	
AT211- 600B	600	640	778	762	796	389	381	
AT211- 700B	700	740	878	862	896	439	431	
AT211- 750B	750	780	918	902	936	459	451	
AT211- 800B	800	840	978	962	996	489	481	
AT211- 900B	900	940	1078	1062	1096	539	531	
AT211-1000B	1000	1040	1178	1162	1196	589	581	
AT211-1100B	1100	1140	1278	1262	1296			430
AT211-1200B	1200	1240	1378	1362	1396			460
AT211-1300B	1300	1340	1478	1462	1496			490
AT211-1400B	1400	1440	1578	1562	1596			530
AT211-1500B	1500	1540	1678	1662	1696			560

- The number of middle supports attached depends on the effective range.

Effective range (mm)	Middle support
500 to 1000	A (1 place)
1100 to 1500	B, C (2 places)

Cable pattern

Unit: mm

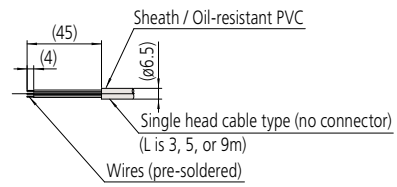
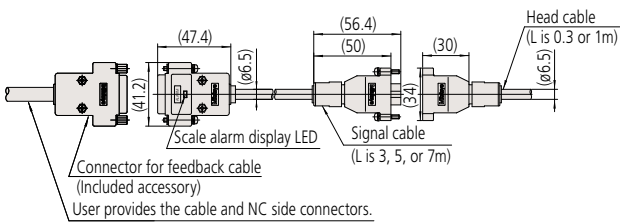
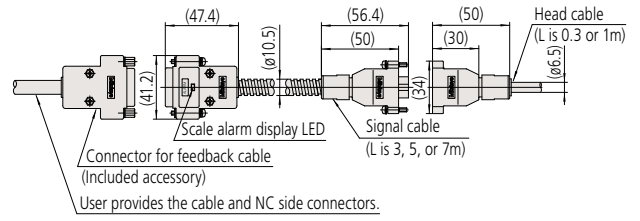
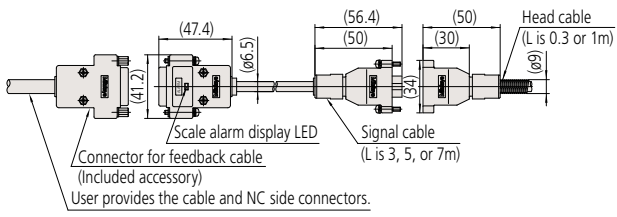

Specification Selection Method

- There is an extensive selection of specifications for the AT211.
- Choose the appropriate numbers and letters below according to specification required.
If you don't have a specification in mind, choose the option with the ●.
- * For special applications not shown in the specifications, please contact us. Additionally, we are also able to meet the 1VP-P Sinusoidal signal output specification.

How to read the code

AT211 - [] - [] - []

Effective range list

Code	Effective range (mm)	Code	Effective range (mm)	Code	Effective range (mm)
0100	100	0450	450	1000	1000
0150	150	0500	500	1100	1100
0200	200	0600	600	1200	1200
0250	250	0700	700	1300	1300
0300	300	0750	750	1400	1400
0350	350	0800	800	1500	1500
0400	400	0900	900		

Mounting method

Code	
A	Multi-point fixing
B	Double-end fixing

Scale reference point

Code	
● 1	50mm pitch
2	Center point
3	Left end
4	Right end

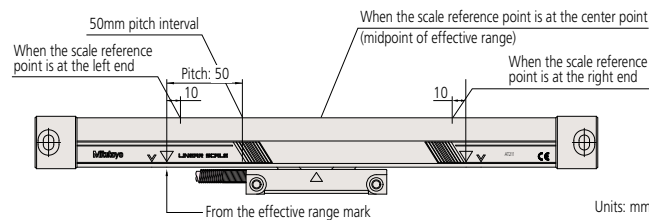

Accuracy (20°C)

Code	
● S	$(3+3L_0/1000) \mu\text{m}$
H	$(2+2L_0/1000) \mu\text{m}$

Note 1: L_0 is the effective range (mm).

Note 2: Type H is used for effective ranges of 500mm or less.

Specification combination table (resolution, response speed, and minimum edge interval)

Resolution (μm)	Minimum edge interval (ns)*					
	125	250	333	500	1000	
0.1	A: 43 (710)	B: 22 (360)	C: 16 (260)	D: 11 (180)	E: 5.4 (90)	
0.2	F: 86 (1400)	G: 43 (710)	H: 32 (530)	J: 22 (360)	K: 11 (180)	
0.5	L: 120 (2000)	M: 110 (1800)	N: 81 (1300)	P: 54 (900)	Q: 27 (450)	
1.0	—	R: 120 (2000)	S: 120 (2000)	T: 110 (1800)	U: 54 (900)	
2.5	—	—	—	W: 120 (2000)	X: 120 (2000)	
5.0	—	—	—	—	Y: 120 (2000)	

* Codes A to Y show the maximum response speed in m/min, values in () are mm/s.

Note: The minimum edge interval varies 0 to -10% based on the operating environmental conditions.

(Example)

AT211 - 1500A1S - P1 - AB

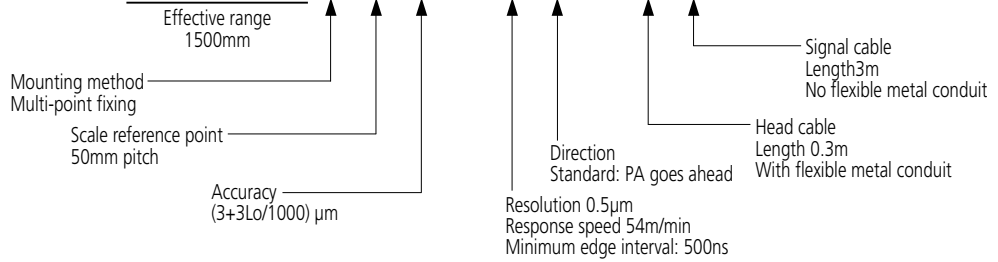

Signal cable

Code	Length (L)	Flexible metal conduit*1
● A	3m	Yes
B	3m	No
C	5m	Yes
D	5m	No
E	7m	Yes
F	7m	No
G*2	3m	No
H*2	5m	No
J*2	7m	No
X	No signal cable	

*1 The cable is enclosed in a flexible metal conduit or else is PVC sheathed.
 *2 The connector (CN3) for signal cables G, H, and J are half-pitch connectors.

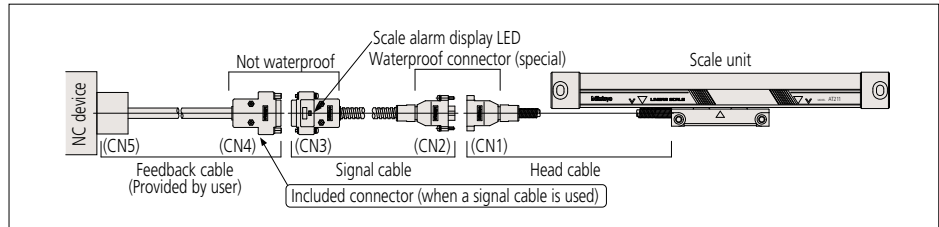

Connector for signal cable (CN3) (pin type)

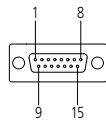

Pin No.	Signal	Pin No.	Signal
1, 2, 13	0V	8	PB
3, 4, 11	+5V	9	PZ
5	PA	10	PZ
6	PA	12, 14	Not used
7	PB	15	F.G

Applicable connector (CN4):
 HDAB-15S (Hirose Electric or equivalent product (D-sub series) may be used)

Output circuit specification

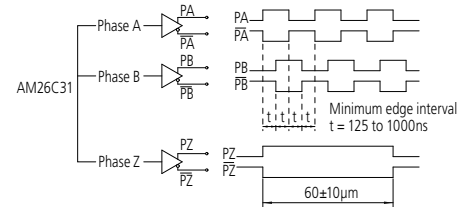

Head cable

Code	Length (L)	Flexible metal conduit	Connector (CN1)
● A	0.3m	Yes	Special waterproof
B	0.3m	No	Special waterproof
C	1m	No	Special waterproof
D	3m	No	No
E	4m		
F	5m		
H	7m		
J	8m		
K	9m		

Note: The cable is enclosed in a flexible metal conduit or else is PVC sheathed.

Single head cable type (no connector)

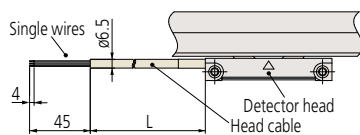

ALM signal for single head cable type (no connector)

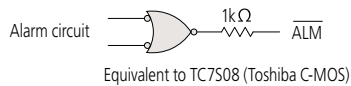

Wire color	Signal	Wire color	Signal
White, black	0V	Blue	PB
Brown, red	+5V	Purple	PZ
Orange	PA	Gray	PZ
Yellow	PA	Pink	ALM
Green	PB		

Direction

Code	
● 1	Standard: PA goes ahead
2	Reverse: PB goes ahead

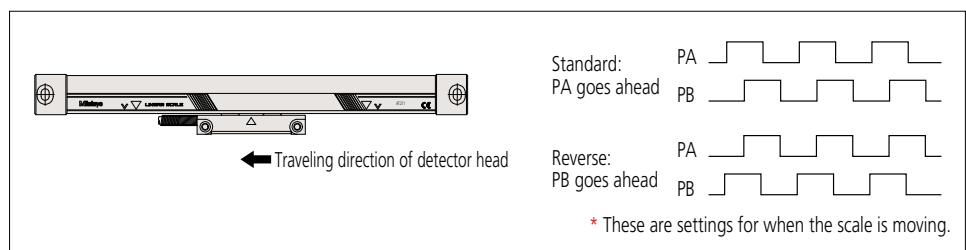

Assembly Type AT Series

Square Wave Signal Output Type Scale Unit (Standard type)

AT203



Features

- The maximum effective measurement length of 6000mm enables use on large machines (such as for LCD production).
- The travel length of the linear scale is output with 2-phase square wave signals, which can be used as a feedback signal for NC machine tools.
- The pulse signal unit (PSU) is no longer needed, and the AT203 can be directly connected to the NC machine tool.
- The maximum response speed is 2000mm/s. (When resolution is 1μm and the minimum edge interval is 250ns)

Specifications

Item	Code	AT203
Detection method		Photoelectric type transmission linear encoder
Output		Two 90° phase-shifted square wave signals
Output method		Differential line driver
Signal output pitch		20μm
Resolution		1, 0.5, 0.1μm (switched using DIP switches)
Effective range		100 to 6000mm
Accuracy (20°C)		Effective range 100 to 1500mm (3+3L ₀ /1000) μm Effective range 1600 to 3000mm (5+5L ₀ /1000) μm Effective range 3250 to 6000mm (5+8L ₀ /1000) μm L ₀ : Effective range (mm)
Maximum response speed		11 to 120m/min (Depends on the resolution and minimum edge interval) (See separate table)
Scale reference point pitch		50mm
Main scale thermal expansion coefficient		≈ 8 × 10 ⁻⁶ / K
Power supply voltage		5VDC ± 5%
Maximum current consumption		250mA
Operating/storage temperature		0 to 45°C, -20 to 70°C (no condensation)
Operating/storage humidity (relative humidity)		20 to 80% RH (no condensation)
Sliding force		5N max.

Signal cable 3m (optional accessory) **Part No.09AAA353B**

Signal cable 5m (included accessory) **Part No.09AAA353A**

Pin assignment

Pin No.	Function
1	0V
2	0V
3	+5V
4	+5V
5	PA
6	PA
7	PB
8	PB
9	PZ
10	PZ
11	+5V
12	N.C.
13	0V
14	N.C.
15	F.G

Connector used: HDAB-15P (Hirose Electric)

Applicable selectable: HDAB-15S (Hirose Electric)

Output signal waveform

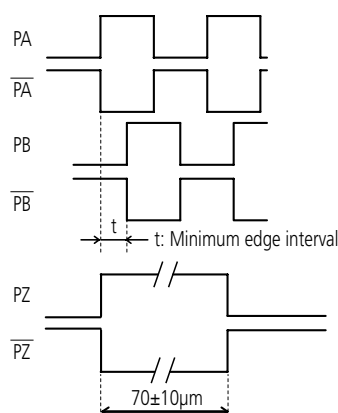

Maximum response speed*

Minimum edge interval	Resolution	Maximum response speed (m/min)		
		1 μm	0.5 μm	0.1 μm
500ns		★110 (50)	54 (50)	11 (11)
250ns		120 (50)	110 (50)	22 (22)

The ★ indicates the setting when shipped

* Values in () are for effective ranges of 3250mm and more.

* The minimum edge interval varies 0 to -10% based on the operating environmental conditions.

Direction

Internal DIP switches can be used to switch between the standard and reverse directions.

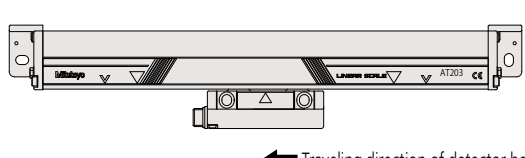

Standard:
PA goes ahead

Reverse:
PB goes ahead

* This is in the standard direction when shipped.

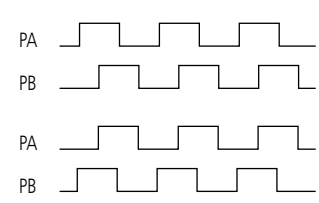

Wiring example

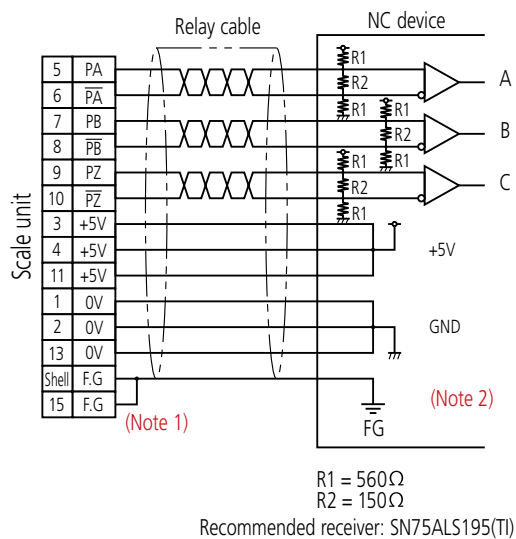

Note 1: When the shield has a drain wire, connect it to Pin 15.

Note 2: Always ground the shield for relay cables by, for example, connecting it to an earth conductor.

AT203 scale unit mounting dimensions

• AT203-100 to 3000

Unit: mm

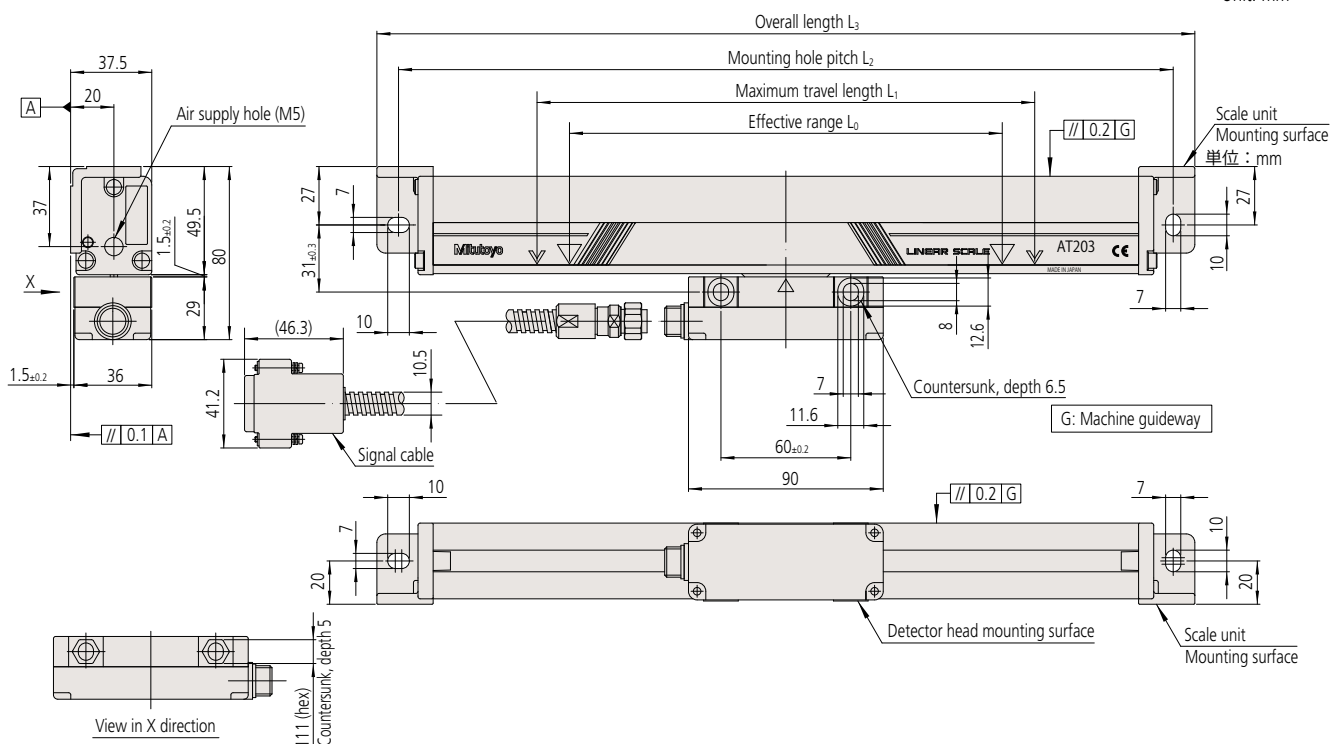

Order No.	Code	Effective range L_0 (mm)	Maximum travel length L_1 (mm)	Mounting hole pitch L_2 (mm)	Overall length L_3 (mm)	L_4 (mm)	L_5 (mm)	L_6 (mm)
539-411-30	AT203-100	100	120	248	268			
539-412-30	AT203-150	150	170	298	318			
539-413-30	AT203-200	200	220	348	368			
539-414-30	AT203-250	250	270	398	418			
539-415-30	AT203-300	300	330	458	478			
539-416-30	AT203-350	350	380	508	528			
539-417-30	AT203-400	400	430	558	578			
539-418-30	AT203-450	450	480	608	628			
539-419-30	AT203-500	500	540	668	688			
539-421-30	AT203-600	600	650	778	798			
539-423-30	AT203-700	700	760	888	908			
539-424-30	AT203-750	750	810	938	958			
539-425-30	AT203-800	800	860	988	1008			
539-426-30	AT203-900	900	960	1088	1108			
539-427-30	AT203-1000	1000	1060	1188	1208	594		
539-428-30	AT203-1100	1100	1160	1288	1308	644		
539-429-30	AT203-1200	1200	1260	1388	1408	694		
539-430-30	AT203-1300	1300	1360	1488	1508	744		
539-431-30	AT203-1400	1400	1460	1588	1608	794		
539-432-30	AT203-1500	1500	1560	1688	1708	844		
539-433-30	AT203-1600	1600	1690	1818	1838		610	
539-434-30	AT203-1700	1700	1790	1918	1938		650	
539-435-30	AT203-1800	1800	1890	2018	2038		670	
539-436-30	AT203-2000	2000	2100	2228	2248		740	
539-437-30	AT203-2200	2200	2300	2428	2448		800	
539-438-30	AT203-2400	2400	2500	2628	2648	1314	1300	650
539-439-30	AT203-2500	2500	2600	2728	2748	1364	1340	670
539-440-30	AT203-2600	2600	2700	2828	2848	1414	1400	700
539-441-30	AT203-2800	2800	2900	3028	3048	1514	1500	750
539-442-30	AT203-3000	3000	3100	3228	3248	1614	1600	800

• AT203-100 to 3000

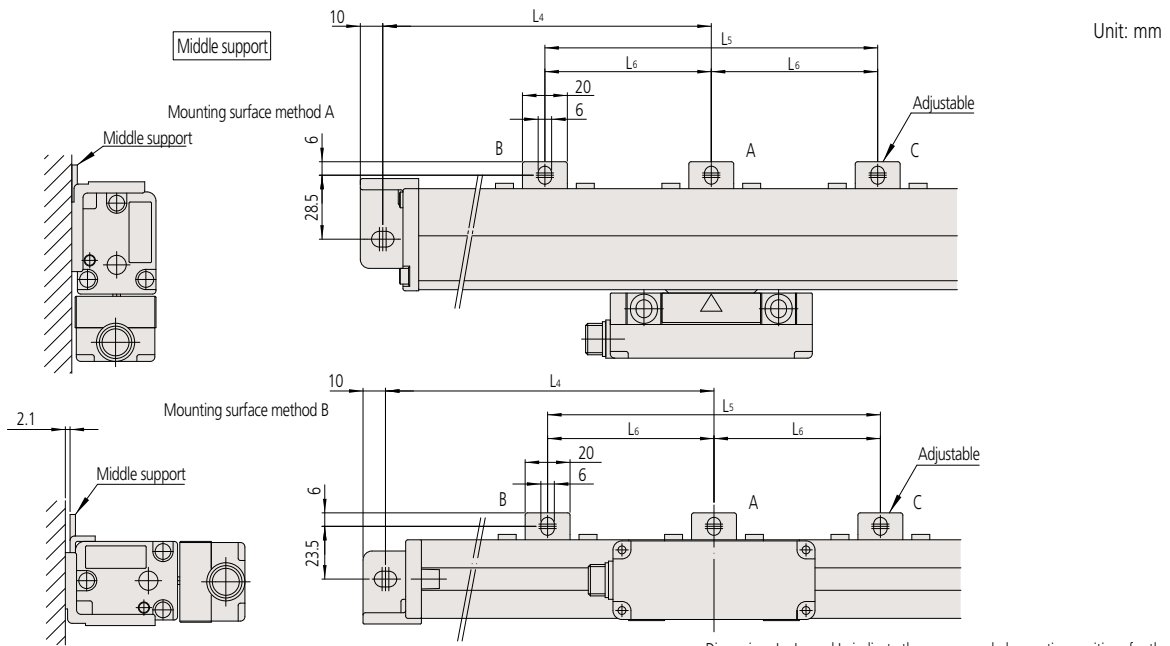

Unit: mm

• Dimensions L_4 , L_5 and L_6 indicate the recommended mounting positions for the middle supports included with scale units with an effective range of 1000mm and more. (The position of the middle support is adjustable in the measuring direction.)

Effective range (mm)	Middle support
1000 to 1500	A (1 place)
1600 to 2200	B, C (2 places)
2400 to 3000	A, B, C (3 places)

Assembly Type AT Series
AT203

• AT203-3250 to 6000

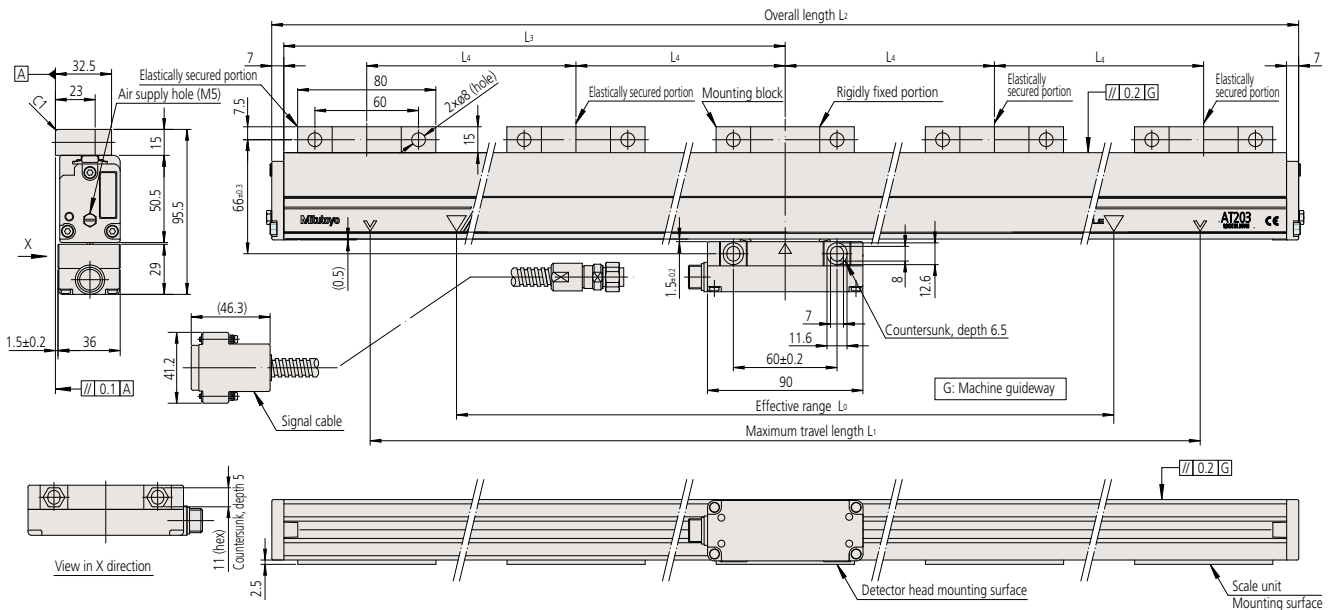

Order No.	Code	Effective range L_0 (mm)	Maximum travel length L_1 (mm)	Overall length L_2 (mm)	L_3 (mm)	L_4 (mm)	No. of mounting blocks
539-443-30	AT203-3250	3250	3350	3464	1725	800	5
539-444-30	AT203-3500	3500	3600	3714	1850	850	
539-445-30	AT203-3750	3750	3850	3964	1975	930	
539-446-30	AT203-4000	4000	4100	4214	2100	1000	
539-447-30	AT203-4250	4250	4350	4464	2225	1050	
539-448-30	AT203-4500	4500	4600	4714	2350	1100	7
539-449-30	AT203-4750	4750	4850	4964	2475	800	
539-450-30	AT203-5000	5000	5100	5214	2600	830	
539-451-30	AT203-5250	5250	5350	5464	2725	870	
539-452-30	AT203-5500	5500	5600	5714	2850	910	
539-453-30	AT203-5750	5750	5850	5964	2975	950	
539-454-30	AT203-6000	6000	6100	6214	3100	1000	

Assembly Type AT Series

Slim Sealed Type

AT217-TL / AT217-TL-B

Features

- The displacement of the scale is output in 2-phase square wave signals and it can be used as feedback signal.
- Can be connected directly to NC machine tools.
- Since cable can be separated from the detector head, it is excellent in maintenance.

Specifications

Model	AT217-TL/AT217-TL-B
Effective range	100 to 1500mm (20 models)
Resolution	1 μm
Accuracy (20°C)	(5+5L _o /1000)μm
Output signal	Two 90° phase-shifted sinusoidal signals
Maximum response speed	50m/min
Signal output pitch	20μm
Scale reference point	Output in 50mm pitch
Operating temperature	0 to 45°C

* The indication accuracy does not include quantizing error. L_o: Effective range (mm)

AT217-TL		Effective range L _o (mm)	Signal cable length (m)
Order No.	Model		
529-461-5	AT217-100TL	100 (4")	5
529-462-5	AT217-150TL	150 (6")	
529-463-5	AT217-200TL	200 (8")	
529-464-5	AT217-250TL	250 (10")	
529-465-5	AT217-300TL	300 (12")	
529-466-5	AT217-350TL	350 (14")	
529-467-5	AT217-400TL	400 (16")	
529-468-5	AT217-450TL	450 (18")	
529-469-5	AT217-500TL	500 (20")	
529-471-5	AT217-600TL	600 (24")	
529-473-5	AT217-700TL	700 (28")	
529-474-5	AT217-750TL	750 (30")	
529-475-5	AT217-800TL	800 (32")	
529-476-5	AT217-900TL	900 (36")	
529-477-5	AT217-1000TL	1000 (40")	
529-478-5	AT217-1100TL	1100 (44")	
529-479-5	AT217-1200TL	1200 (48")	
529-480-5	AT217-1300TL	1300 (52")	
529-481-5	AT217-1400TL	1400 (56")	
529-482-5	AT217-1500TL	1500 (60")	

AT217-TL-B		Effective range L _o (mm)	Signal cable length (m)
Order No.	Model		
529-461-7	AT217-100TL-B	100 (4")	5
529-462-7	AT217-150TL-B	150 (6")	
529-463-7	AT217-200TL-B	200 (8")	
529-464-7	AT217-250TL-B	250 (10")	
529-465-7	AT217-300TL-B	300 (12")	
529-466-7	AT217-350TL-B	350 (14")	
529-467-7	AT217-400TL-B	400 (16")	
529-468-7	AT217-450TL-B	450 (18")	
529-469-7	AT217-500TL-B	500 (20")	
529-471-7	AT217-600TL-B	600 (24")	
529-473-7	AT217-700TL-B	700 (28")	
529-474-7	AT217-750TL-B	750 (30")	
529-475-7	AT217-800TL-B	800 (32")	
529-476-7	AT217-900TL-B	900 (36")	
529-477-7	AT217-1000TL-B	1000 (40")	
529-478-7	AT217-1100TL-B	1100 (44")	
529-479-7	AT217-1200TL-B	1200 (48")	
529-480-7	AT217-1300TL-B	1300 (52")	
529-481-7	AT217-1400TL-B	1400 (56")	
529-482-7	AT217-1500TL-B	1500 (60")	

Meaning of Model No.

AT217 - 0100 TL - B

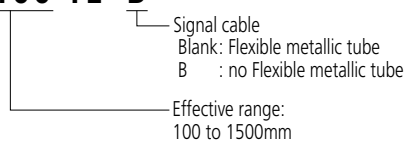

AT217-TL/AT-217-TL-B scale unit mounting dimensions

Unit: mm

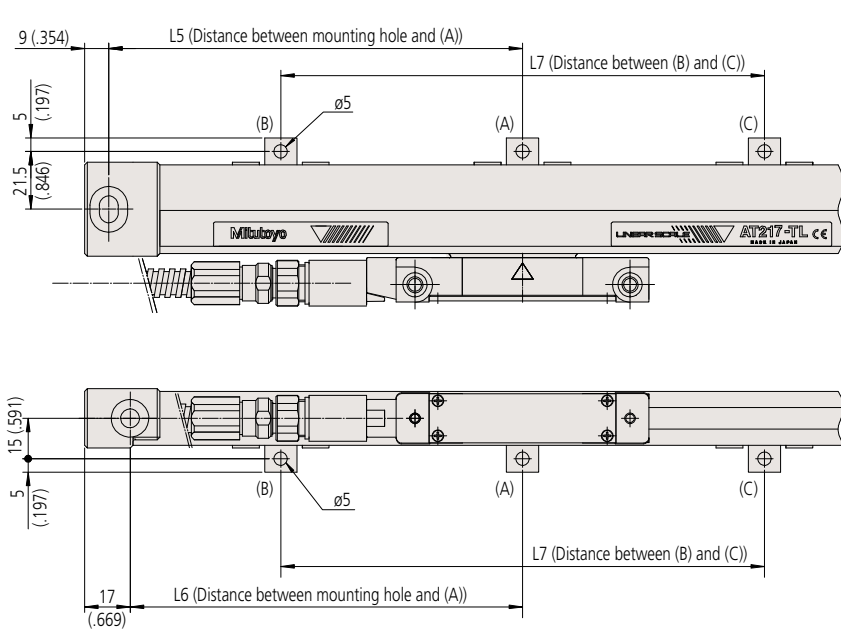
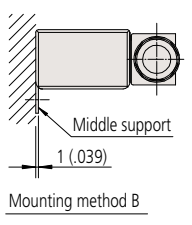
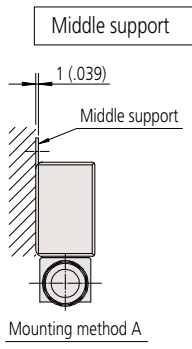
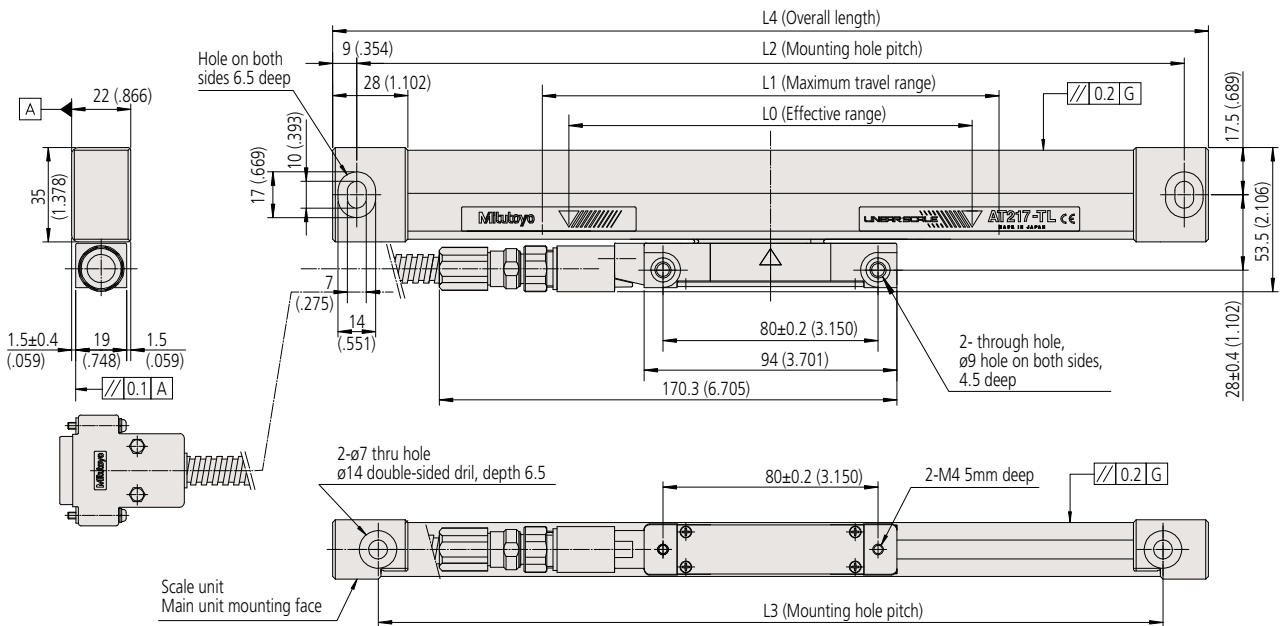

G: Machine guide

Assembly Type AT Series
 AT217-TL/AT217-TL-B

Absolute Scale Unit



Scale Format

Applicable Systems*1		Resolution				
		0.005μm	0.05μm	0.1μm	0.01μm	0.001μm
FANUC Ltd. NC control device	FS-i Series, POWER Mate i Serial i interface	ABS AT555	ABS AT553 ABS AT1153	ABS ST758	ABS ST1351	ABS ST1352
Mitsubishi Electric Corporation MITSUBISHI CNC Series	Applicable amplifier: MDS-D/MDS-DH Series	ABS AT545	ABS AT543 ABS AT1143	ABS ST748	—	—
Mitsubishi Electric Corporation MELSERVO Series	MR-J4/MR-J3 Series	ABS AT545A *2	ABS AT543A	ABS ST748A	ABS ST1341A	ABS ST1342A
Yaskawa Electric Corporation Σ-VII, Series	Servopack: SGDv, SGDS	—	—	ABS ST788A	ABS ST1381A	ABS ST1382A
Panasonic Corporation, Motor business unit MINAS Series	MINAS-A5, A5L, A5N, A5NL Series MINAS-A4, A4P, A4N, A4NL Series	—	ABS AT573A	ABS ST778A	ABS ST1371A	ABS ST1372A
Siemens AG	DRIVE-CLIQ	—	ABS AT1123	—	ABS AT524	ABS AT527
Servo Amplifier supporting Mitutoyo ENSIS Interface	Nikki Denso Co., Ltd. VCII / VC / VPS Series	—	ABS AT503A	ABS ST708A	ABS ST1301A	ABS ST1302A
	Servoland Corporation SVF Series					
	PMAC JAPAN Co., Ltd. UMAC-Turbo PMAC2					
	Other control device manufacturers	ABS AT505 ABS AT505A	ABS AT503			

*1 For details regarding the applicable system, please consult with the individual manufacturer.

*2 Only for the MR-J4/MR-J3 series

Specifications

Series	Scale Type	Maximum effective range	Maximum response speed	Accuracy (20°C)*4
ABS ST700 Compact Type Series	Separate Type	6000mm	5m/s	(5+5L ₀ /1000) μm
ABS ST1300 Series	Separate Type	12000mm	8m/s	±5μm
ABS AT500 Series	SC Type	2200mm	2.5m/s	(3+3L ₀ /1000) μm
	HC Type	1000mm	2.5m/s (1.2m/s*3)	(2+2L ₀ /1000) μm
	HR/HL Type	350mm		
ABS AT1100 Series	Assembly Type	3040mm	3m/s	(3+5L/1000) μm L=140 to 2040mm (5+5L/1000) μm L=2240 to 3040mm

*3 Maximum response speed of 0.005μm resolution type

*4 L₀=effective range (mm); scale base type accuracy for the ST700 compact type series

Absolute system, linear scale principle (e.g. ABS AT500 Series)

[Figure 1]

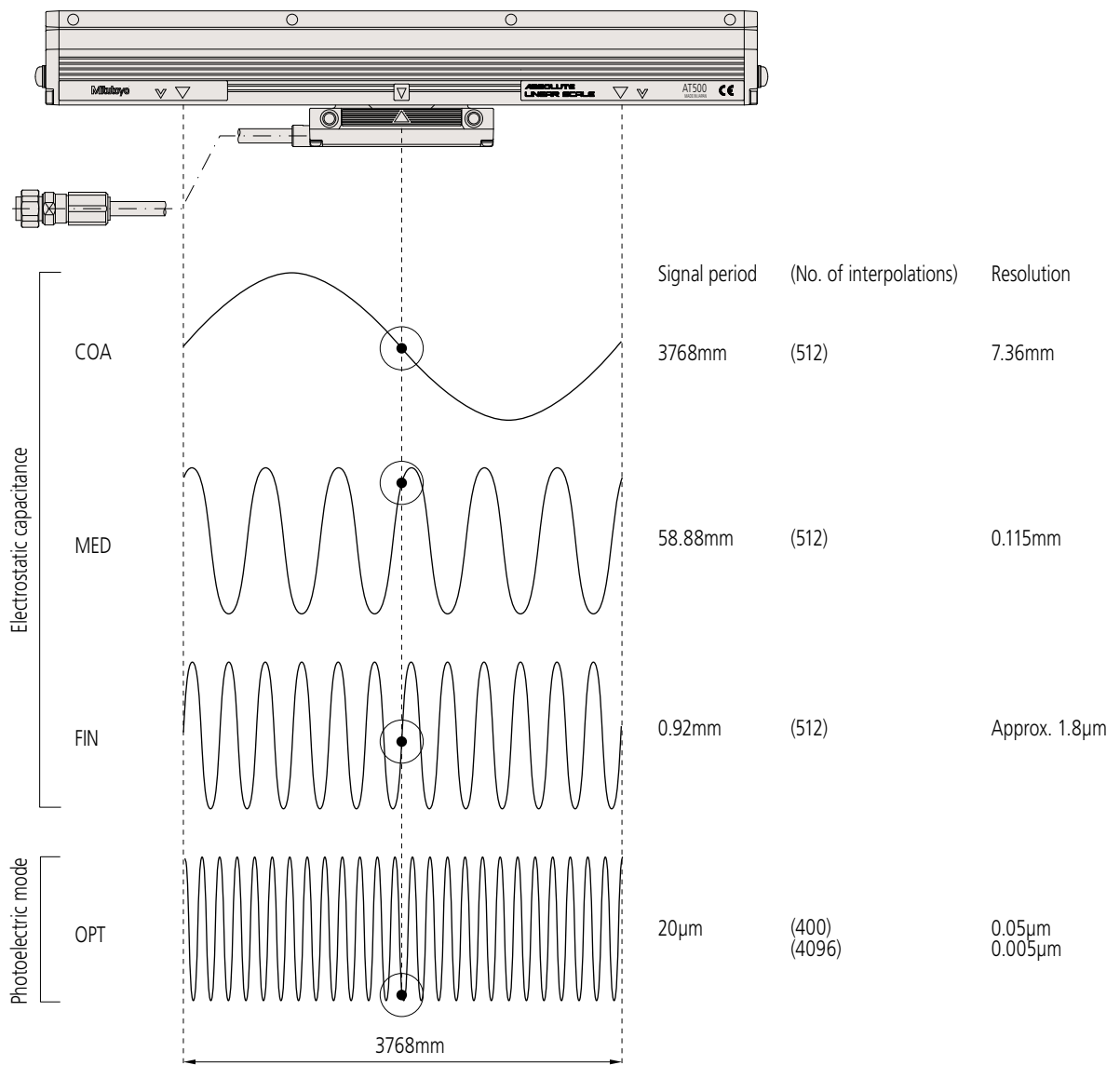

As shown in Figure 1, when power is supplied to the linear scale the COA signal position is detected, and based on this the MED wavelength and position is detected.

In the same way, from the microprocessor that detects the FIN and OPT signal positions, an ultimate absolute value of resolution of 0.05μm/0.005μm is obtained.

Direction of absolute unit scale data increase

- ABS ST700 Compact Type Series

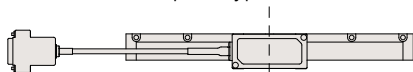

The data will increase when the detector moves in this direction.

- ABS ST1300 Series

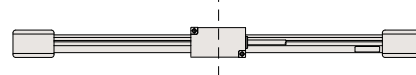

The data will increase when the detector moves in this direction.

- ABS AT1100 Series



The data will increase when the detector moves in this direction.

- ABS AT500 Series



The data will increase when the detector moves in this direction.

Separate Type ABS ST Series

Absolute Scale Unit (High environmental resistance type)

ABS ST700 Compact Type Series

ABSOLUTE™



Scale base type

Features

- Absolute measurement with separate type scales
- Non-contact detection is optimal for high speed and high acceleration of linear motors, etc.
- Electromagnetic induction principle means scales are unaffected by contamination
- The detector head is approximately 1/3 the previous model size: 50mm (W) × 28mm (D) × 11mm (H)
- Cable outlets can be in four directions, with mounting holes on the top and sides
- Accuracy (5+5L/1000)μm is realized (previous models: (8+5L/1000) μm)
*L: Effective range (mm)
- Compatible with servo amplifiers from a range of companies (high-speed serial interfaces)

How to read the code

ABS ST7 0 8 A L - 100 A - R

Absolute type

Series

Separate type Absolute linear scale

ABS ST700 compact type series (effective range ≤ 3m)

ABS ST700L compact type series (3.2m ≤ effective range ≤ 6m)

Interface specification*1

0: For Mitutoyo ENSIS high-speed serial

ABS ST708A, ST708AL

4: Mitsubishi Electric Corporation high-speed serial

ABS ST748A, ST748AL

ABS ST748, ST748L

5: FANUC Ltd. high-speed serial

ABS ST758, ST758L

7: Panasonic Corporation, Motor business unit high-speed serial

ABS ST778A, ST778AL

8: Yaskawa Electric Corporation high-speed serial

ABS ST788A, ST788AL

A: Scale base type

Effective range: 100mm to 6000mm

Blank: 100mm to 3000mm

L: 3200mm to 6000mm

Head cable outlets

R: Right

L: Left

U: Up

D: Down

Communication method

A: 2 wire

Blank: 4 wire

Detector head shape and resolution

8: Shape 50mm (W) × 28mm (D) × 11mm (H)

Resolution 0.1μm

Applicable interfaces

Applicable interfaces*1	FANUC Ltd. FS-i Series, POWER Mate i Series
	Mitsubishi Electric Corporation MELSERVO MR-J4/MR-J3 Series
	Mitsubishi Electric Corporation CNC Series MDS-D/MDS-DH Series
	Yaskawa Electric Corporation Σ-VII Series
	Panasonic Corporation, Motor business unit MINAS-A5, A5L, A5N, A5NL Series, MINAS-A4, A4P, A4N, A4NL Series
	Mitutoyo Corporation ENSIS*2 Nikki Denso Co., Ltd. VC II / VC / VPS Series Servoland Corporation SVF Series PMAC JAPAN Co., Ltd. UMAC-Turbo PMAC2

*1 For details (connectivity) regarding the applicable system, please consult with the individual manufacturer.

*2 ENSIS is a registered trademark of Mitutoyo Corporation.

Specifications

Item	Scale Type	Scale base type
Resolution		0.1μm (0.05μm: special order)
Detection method		Electromagnetic induction Absolute position detection method*
Shape		Separate type scale
Effective range (accuracy guarantee range)		100 to 3000mm / 3200 to 6000mm
Accuracy (20°C)		(5+5L/1000) μm L: Effective range mm
Maximum feed speed		5 m/s
Thermal expansion coefficient		(12.0±1.5) ×10 ⁻⁶ /°C (when attached to material equivalent to steel)
Operating conditions	Temperature	0 to 50°C
	Humidity	20 to 80%RH
Storage conditions	Temperature	-20 to 70°C
	Humidity	20 to 80%RH
Power supply voltage		5V±10% (at the detector head) (Ripple and spike noise should not exceed 100mV)
Current consumption		270mA (Max.)
Vibration resistance		300m/s ² (55 to 2000Hz)
Shock resistance		500m/s ² (half-sine, 11ms)
Head cable	Length/cable diameter	1m / ø3.8mm (high-flex cable)
	Connector	1) D-sub (15-pin pin type) connector (not waterproof) 2) D-sub (9-pin socket type) connector (not waterproof): for ST788A
Maximum signal cable length		Up to 29m (head cable length included) (Please consult the user's manual)
Detector mounting		1 location each on top and sides
Direction of cable outlet		4 sides (top, bottom, left, right) can be selected
EMC standard		CE mark standard

Note: If considering using in an environment in which cutting fluid, etc., is used, please consult our nearest sales department.

System configuration

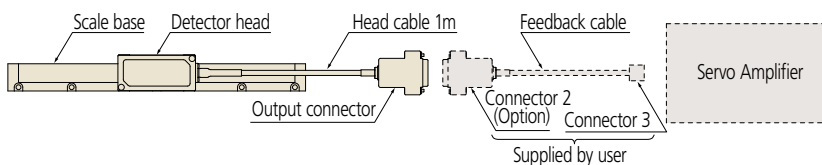

Feedback cable

Yaskawa Electric Corporation serial cable can be used as the feedback cable for connecting to the Yaskawa Electric Corporation servo amplifier.
Cable type number: JZSP-CLP70-□□E (03,05,10,15,20)

When wishing to connect a feedback cable to the Mitsubishi Electric Corporation MR-J4/MR-J3 series, please reference the code numbers below and order from our company.

For the MR-J4/MR-J3 series 5m: **No.06ACF117A**
10m: **No.06ACF117B**

Output specifications

• ST788A (L)

Output connector (socket type)
D-sub 9-pin
Applicable connector
17JE-23090-02 (D2C) (DDK)

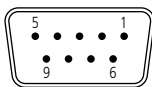

Alternately, an equivalent product (D-sub series) can be used

Pin No.	Signal
1	+5V (Vcc)
2	RQ/DT (S)
3	+5V (Vcc)
4	N.C
5	0V (GND)
6	RQ/DT (/S)
7	N.C
8	N.C
9	0V (GND)
Connector shell	F.G

Note: Leave test terminals (Pin No. 7 and 8) disconnected during use.

• ST748A (L), ST778A (L), ST708A (L)

Output connector (pin type)
D-sub 15-pin
Applicable connector
HDAB-15S (Hirose Electric)

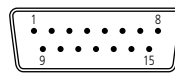

Alternately, an equivalent product (D-sub series) can be used

Pin No.	Signal
1	0V (GND)
2	0V (GND)
3	+5V
4	+5V
5	N.C
6	N.C
7	RQ/DT
8	RQ/DT
9	N.C
10	N.C
11	+5V
12	N.C
13	0V (GND)
14	N.C
15	F.G
Connector shell	F.G

Note: Leave test terminals (Pin No. 9 and 10) disconnected during use.

• ST748 (L), ST758 (L)

Output connector (pin type)
D-sub 15-pin
Applicable connector
HDAB-15S (Hirose Electric)

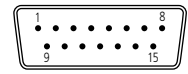

Alternately, an equivalent product (D-sub series) can be used

Pin No.	Signal
1	0V (GND)
2	0V (GND)
3	+5V
4	+5V
5	DT
6	DT
7	RQ
8	RQ
9	N.C
10	N.C
11	+5V
12	N.C
13	0V (GND)
14	N.C
15	F.G
Connector shell	F.G

Note: Leave test terminals (Pin No. 9 and 10) disconnected during use.

Mounting dimensions

- Scale base type (100 to 3000mm)

Unit: mm

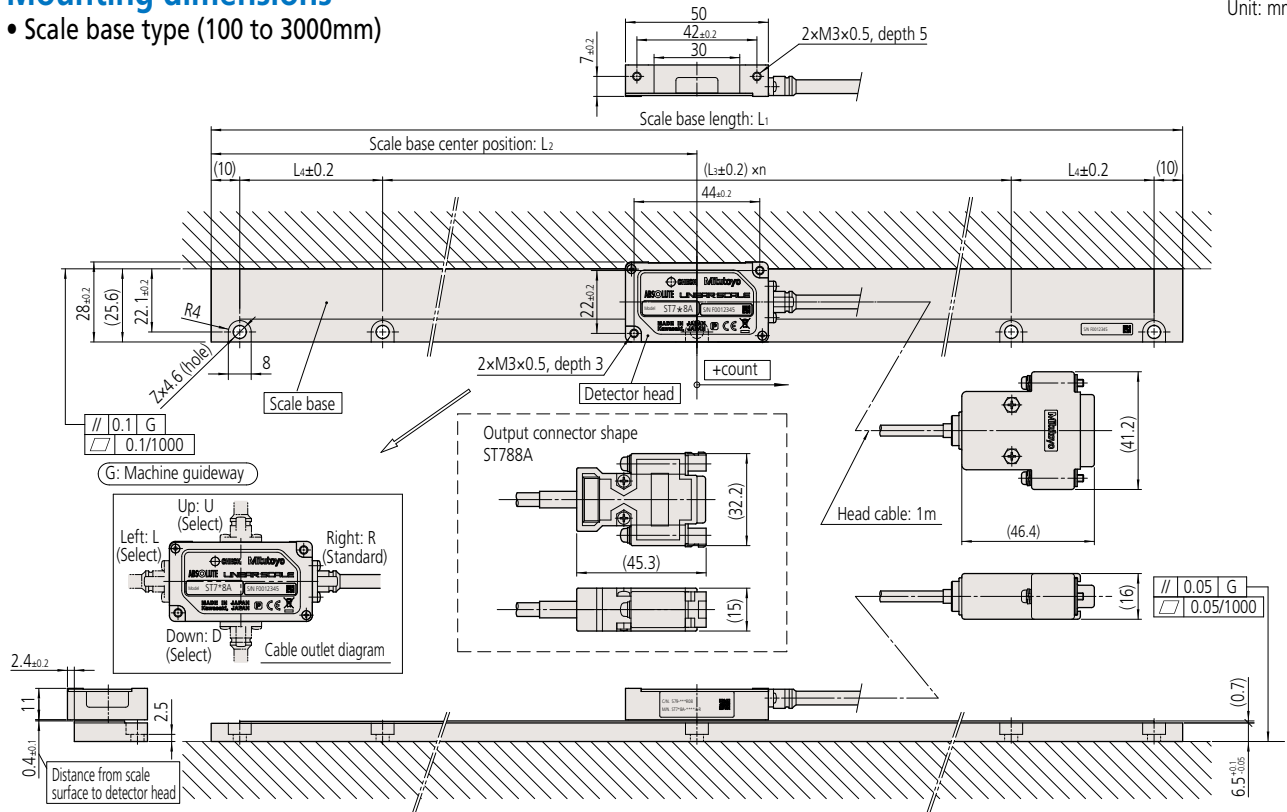

Dimensions

Order No.	Code	Effective range (mm)	Maximum travel length (mm)	L ₁ (mm)	L ₂ (mm)	L ₃ (mm)	n	L ₄ (mm)	No. of mounting holes Z
579-301* □ 8	ST7◇8 (A) -100A-*	100	110	180	90	80	2	—	3
579-302* □ 8	ST7◇8 (A) -200A-*	200	210	280	140	130			
579-303* □ 8	ST7◇8 (A) -300A-*	300	310	380	190	180			
579-304* □ 8	ST7◇8 (A) -400A-*	400	410	480	240	230	4	80	5
579-305* □ 8	ST7◇8 (A) -500A-*	500	510	580	290	230			
579-306* □ 8	ST7◇8 (A) -600A-*	600	610	680	340	230			
579-307* □ 8	ST7◇8 (A) -700A-*	700	710	780	390	230	6	80	7
579-308* □ 8	ST7◇8 (A) -800A-*	800	810	880	440	230			
579-309* □ 8	ST7◇8 (A) -900A-*	900	910	980	490	230			
579-310* □ 8	ST7◇8 (A) -1000A-*	1000	1010	1080	540	230	8	80	9
579-311* □ 8	ST7◇8 (A) -1100A-*	1100	1110	1180	590	230			
579-312* □ 8	ST7◇8 (A) -1200A-*	1200	1210	1280	640	230			
579-313* □ 8	ST7◇8 (A) -1300A-*	1300	1310	1380	690	230	10	80	11
579-314* □ 8	ST7◇8 (A) -1400A-*	1400	1410	1480	740	230			
579-315* □ 8	ST7◇8 (A) -1500A-*	1500	1510	1580	790	230			
579-316* □ 8	ST7◇8 (A) -1600A-*	1600	1610	1680	840	230	12	80	13
579-317* □ 8	ST7◇8 (A) -1700A-*	1700	1710	1780	890	230			
579-318* □ 8	ST7◇8 (A) -1800A-*	1800	1810	1880	940	230			
579-319* □ 8	ST7◇8 (A) -1900A-*	1900	1910	1980	990	230	14	80	15
579-320* □ 8	ST7◇8 (A) -2000A-*	2000	2010	2080	1040	230			
579-321* □ 8	ST7◇8 (A) -2100A-*	2100	2110	2180	1090	230			
579-322* □ 8	ST7◇8 (A) -2200A-*	2200	2210	2280	1140	230	12	80	17
579-323* □ 8	ST7◇8 (A) -2300A-*	2300	2310	2380	1190	230			
579-324* □ 8	ST7◇8 (A) -2400A-*	2400	2410	2480	1240	230			
579-325* □ 8	ST7◇8 (A) -2500A-*	2500	2510	2580	1290	230	14	80	17
579-326* □ 8	ST7◇8 (A) -2600A-*	2600	2610	2680	1340	230			
579-327* □ 8	ST7◇8 (A) -2700A-*	2700	2710	2780	1390	230			
579-328* □ 8	ST7◇8 (A) -2800A-*	2800	2810	2880	1440	230	14	80	17
579-328* □ 8	ST7◇8 (A) -2900A-*	2900	2910	2980	1490	230			
579-330* □ 8	ST7◇8 (A) -3000A-*	3000	3010	3080	1540	230			

The ◇ code indicates the interface specification (0,4,5,7,8).

The Order No. and the * code indicate the direction of the head cable (R, L, U, D).

The □ in the Order No. is as described below.

ST708A: 0
ST748A: 4
ST748: 3
ST758: 5
ST778A: 7
ST788A: 8

Mitutoyo

Mounting dimensions

- Scale base type (3200 to 6000mm)

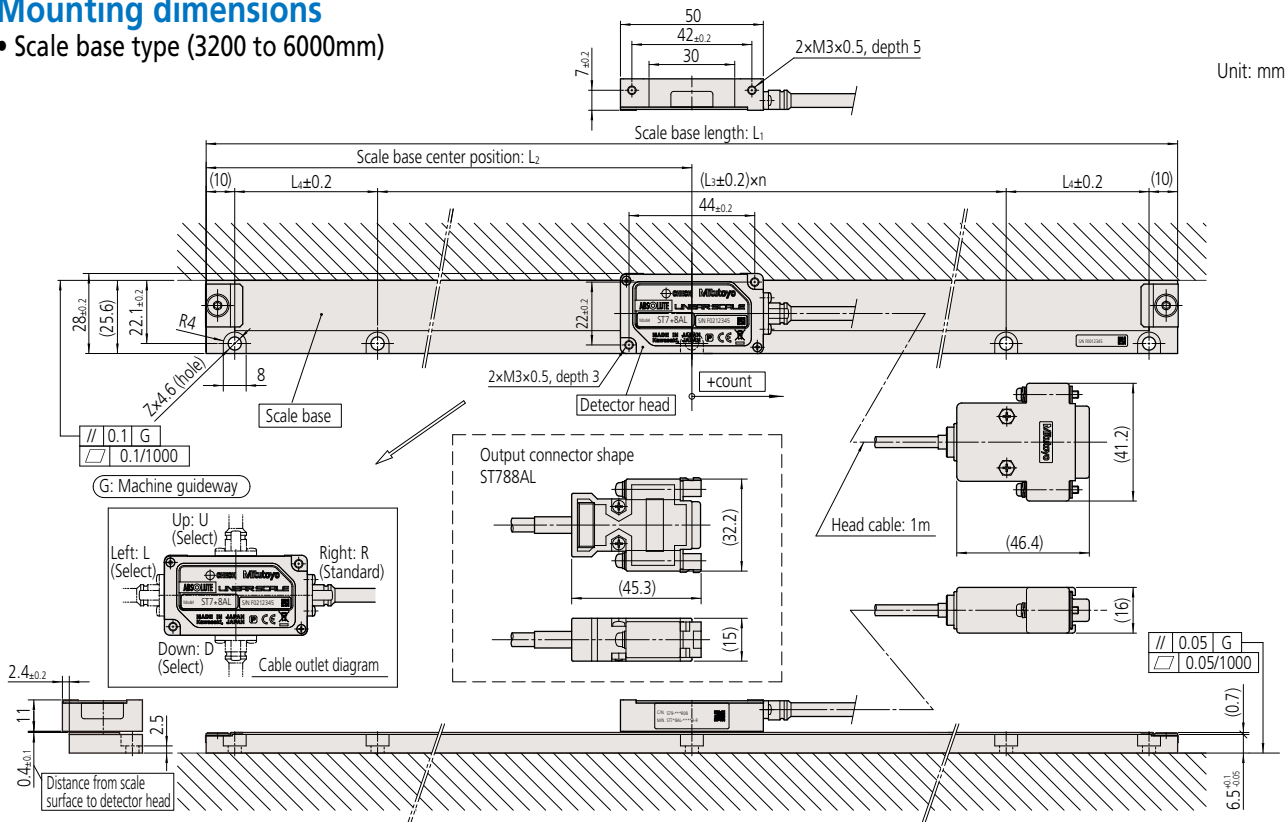

Dimensions

Order No.	Code	Effective range (mm)	Maximum travel length (mm)	L ₁ (mm)	L ₂ (mm)	L ₃ (mm)	n	L ₄ (mm)	Z
579-331* □ 8	ST7◇8 (A) L-3200A-*	3200	3210	3280	1640	200	14	230	17
579-332* □ 8	ST7◇8 (A) L-3400A-*	3400	3410	3480	1740		16	130	19
579-333* □ 8	ST7◇8 (A) L-3600A-*	3600	3610	3680	1840		16	230	19
579-334* □ 8	ST7◇8 (A) L-3800A-*	3800	3810	3880	1940		18	130	21
579-335* □ 8	ST7◇8 (A) L-4000A-*	4000	4010	4080	2040		18	230	21
579-336* □ 8	ST7◇8 (A) L-4200A-*	4200	4210	4280	2140		20	130	23
579-337* □ 8	ST7◇8 (A) L-4400A-*	4400	4410	4480	2240		20	230	23
579-338* □ 8	ST7◇8 (A) L-4600A-*	4600	4610	4680	2340		22	130	25
579-339* □ 8	ST7◇8 (A) L-4800A-*	4800	4810	4880	2440		22	230	25
579-340* □ 8	ST7◇8 (A) L-5000A-*	5000	5010	5080	2540		24	130	27
579-341* □ 8	ST7◇8 (A) L-5200A-*	5200	5210	5280	2640		24	230	27
579-342* □ 8	ST7◇8 (A) L-5400A-*	5400	5410	5480	2740		26	130	29
579-343* □ 8	ST7◇8 (A) L-5600A-*	5600	5610	5680	2840		26	230	29
579-344* □ 8	ST7◇8 (A) L-5800A-*	5800	5810	5880	2940		28	130	31
579-345* □ 8	ST7◇8 (A) L-6000A-*	6000	6010	6080	3040		28	230	31

The ◇ code indicates the interface specification (0,4,5,7,8).

The Order No. and the * code indicate the direction of the head cable (R, L, U, D).

The □ in the Order No. is as described below.

- ST708AL: 0
- ST748AL: 4
- ST748L: 3
- ST758L: 5
- ST778AL: 7
- ST788AL: 8

Signal Adjusting Method When Mounting ABS ST700 Series

In order to perform signal adjustment and confirmation after the unit is mounted, conditioning is necessary using a PC and application software (ABS ST700 Signal Adjustment Program). (For conditioning, allow a travel distance of at least 60mm.) The following settings and confirmation are possible with this software:

- 1) Scale signal automatic adjustment → It is necessary to mount the scale base and detector head detector with specified dimensions.
- 2) Scale signal amplitude (signal strength) confirmation
- 3) Scale origin (absolute position data of zero) setting
- 4) Absolute position data confirmation
- 5) Error history clear
- 6) ABS resultant error checking (effective range 3200mm to 6000mm)

• Required items

Item	Quantity	Details	Notes
PC*	1	DOS/V (Windows version)	Provided by user
Conversion unit	1	USB-485(422)DS15P (System Sacom Industry Corp.)	Option (bundle)
Connection cable A	1	USB cable	
Connection cable B	1	RS-485 cable or RS-422 cable	
Application software	1	ABS ST700 Signal Adjustment Program	

* This program requires a PC with the following operating environment.
 PC: DOS/V with Pentium 200 MHz or faster (with USB port)
 Memory: 64MB min. (128MB recommended)
 Program size: 10MB
 OS: Windows95 or later
 Monitor: 256 colors, 800×600 or higher (1024×768 or higher is recommended)
 USB: COM1 is normally used (other ports can also be used)

• "Conversion unit, application software" set

Set No.	Applicable model	Conversion unit	Connection cable B
06ADZ751	ST70 <input type="checkbox"/> A, ST70 <input type="checkbox"/> AL	USB-485 DS15P (main unit)	MIT cable
06ADT457	ST74 <input type="checkbox"/> A, ST74 <input type="checkbox"/> AL	USB-485 DS15P (main unit)	MEL-J4/J3 cable
06ADP485	ST77 <input type="checkbox"/> A, ST77 <input type="checkbox"/> AL ST78 <input type="checkbox"/> A, ST78 <input type="checkbox"/> AL	USB-485 DS15P (main unit)	Y/MAT cable
06ADZ752	ST74 <input type="checkbox"/> L, ST74 <input type="checkbox"/> L	USB-422 DS15P (main unit)	MDS cable
06ADR760	ST75 <input type="checkbox"/> L, ST75 <input type="checkbox"/> L	USB-422 DS15P (main unit)	FUNAC cable

• Connection method

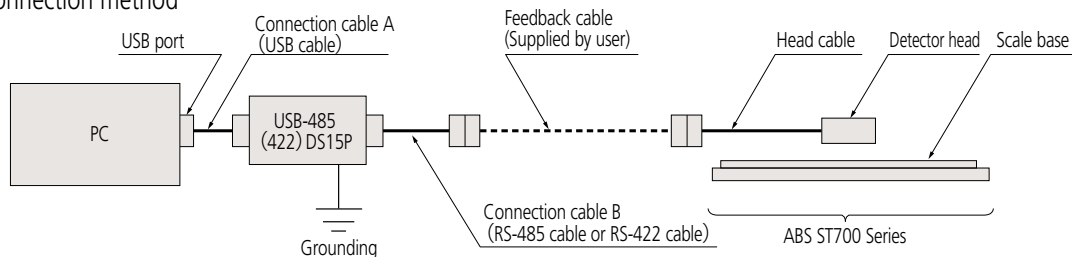

- * To prevent the possibility of electric shock the device must be grounded.
- * When using Part No.06ADZ751, connect the head cable and the connection cable B together.
- * The conversion unit's power source is supplied via connection cable A from the PC USB port.
- * In the "Applicable model" column, 1,2,3,4,8,9 apply to . Prepare the appropriate conversion unit and connection cable B for the scale to be used.

Compatibility of Detector Head and Main Scale

- Note that for the ST700 series (compact type) with an effective range 3000 mm or less or 3200 mm or more, the main scale and the detector head are different so they are not compatible.
- The communication standards are different for the ST7 (L) and ST7 A (L), so they are not compatible.

Main scale		Detector head
For effective range of 3200mm to 6000mm	← Compatible →	For effective range of 3200mm to 6000mm
	← Not compatible →	
For effective range of 3000mm or less	← Compatible →	For effective range of 3000mm or less

MEMO

Separate Type ABS ST Series

Absolute Scale Unit (High environmental resistance type)

ABS ST1300 Series

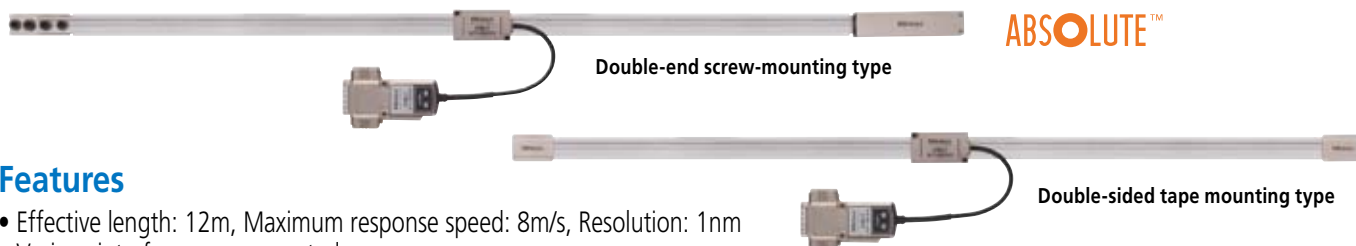

ABSOLUTE™

Features

- Effective length: 12m, Maximum response speed: 8m/s, Resolution: 1nm
- Various interfaces are supported.
- A new detection method has improved robustness in regards to contamination resistance and gap tolerance (in-house testing result).
- There is a choice of mounting method: double-sided tape or double-end screw.
- Signal check program enables integrity check and maintenance.

Meaning of Model No.

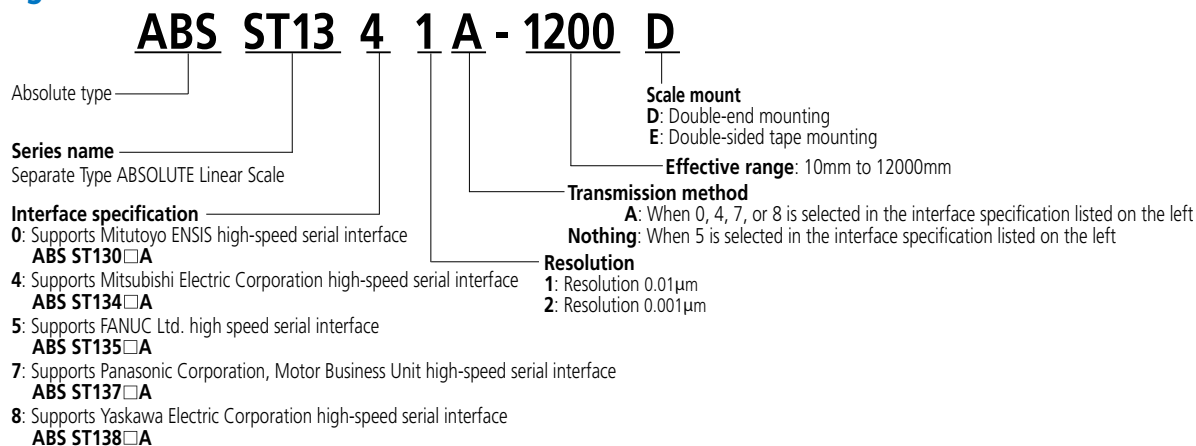

Available Interfaces

Applicable interfaces*1	Mitutoyo ENSIS*2
	Mitsubishi Electric Corporation, MELSERVO MR-J4 Series
	FANUC Ltd.
	Panasonic Corporation, Motor Business Unit MINAS-A5 Series
	Yaskawa Electric Corporation, Σ-VII Series

*1 Be sure to contact each manufacturer for details of the applicable systems (availability of connection).

*2 EENSIS is a registered trademark of Mitutoyo Corporation.

System Configuration

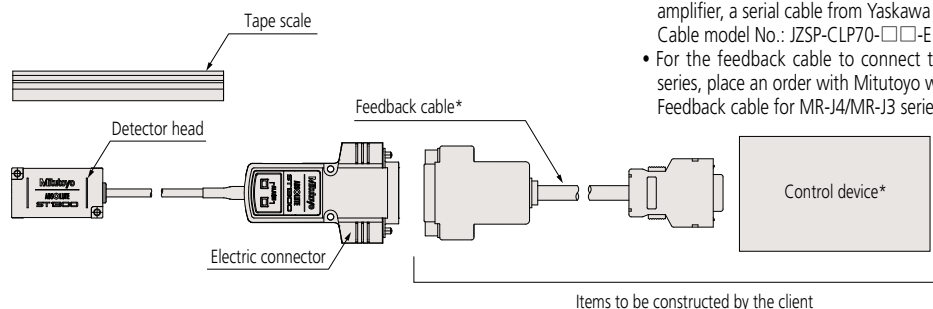

◇ About the feedback cable

- For the feedback cable to connect to the Yaskawa Electric Corporation's servo amplifier, a serial cable from Yaskawa Electric Corporation is available.
Cable model No.: JZSP-CLP70-□□-E (03,05,10,15, 20)
- For the feedback cable to connect to Mitsubishi Electric Corporation MR-J4/MR-J3 series, place an order with Mitutoyo with the following order No. specified.
Feedback cable for MR-J4/MR-J3 series, 5m: No. 06ACF117A, 10m: No.06ACF117B

Note: The feedback cable and control device are to be constructed and connected by the client.

If the feedback cable from Yaskawa Electric Corporation is used, the ST1380A connecting cable (optional: **06AFA434A**) is needed.

Mitutoyo

Specifications

Item	Model	ABS ST1300	
Detection method		Optical reflection type linear encoder	
Scale type		Metal tape	
		Double-end fixation	Double-stick tape fixation
Maximum effective length		12m	3m
Fixing part material		—	Equivalent to iron
			Other than equivalent to iron
Indication accuracy (20°C)		±5µm (1m or less) ±5µm/m (1.1m or more) *4	±5µm (1m or less) ±5µm/m (1.1m or more)
Resolution		0.001µm/0.01µm (switched at shipment)	
Maximum response speed		8m/s or less	
Applicable Interfaces		Mitutoyo ENSIS, Mitsubishi Electric Corporation I/F, FANUC Ltd. I/F, Yaskawa Electric Corporation I/F, Panasonic Corporation I/F	
Expansion coefficient		≈10×10 ⁻⁶ / K *5	≈10×10 ⁻⁶ / K *2
GAP allowance		Initial: ±0.1mm Kinetic: ±0.2mm	
Cable length		1m (Highly curved cable)	
Detector size		40 (D) × 22 (W) × 23 (H) mm	
Operation temperature		0 - 50°C	0 - 50°C *1 When mounting: ±10°C
Storage temperature		-20 - 70°C	-20 - 70°C *3

- *1: Double-sided tape fixing type, careful for the condition of operating temperature range, in case that the sealing surface material is except for Fe equivalent.
- *2: Thermal expansion coefficient occasionally change, as the difference between scale material's and sealing surface material's is excessive.
- *3: Double-sided tape fixing type, the accuracy compensation occasionally change, in case that the sealing surface material is except for Fe equivalent and stored in environment over operating temperature range. Imaging these conditions, double-end fixing type is adopted.
- *4: Tension fix is adopted to be stable the temperature property. Because scale tension is longer 250 µm/m, the accuracy compensation is needed over the system.
- *5: Thermal expansion coefficient after mounted conform to expansion/contraction of mounted surface by changing outer temperature(Double-end fixing type).

Relation between resolution for each supported interface, maximum effective length, and maximum response speed

	Resolution	Maximum effective length (mm)		Maximum response speed
		Double-end fixation	Double-stick tape fixation	
Mitutoyo ENSIS	10nm	12000mm	3000mm	8m/s
	1nm	±2100mm *	±1500mm *	8m/s
Mitsubishi Electric Corporation	10nm	12000mm	3000mm	4m/s
	1nm	±2100mm *	±1500mm *	4m/s
FANUC Ltd.	10nm	12000mm	3000mm	8m/s
	1nm	±2100mm *	±1500mm *	8m/s
Panasonic Corporation	10nm	12000mm	3000mm	4m/s
	1nm	±2100mm *	±1500mm *	0.4m/s
Yaskawa Electric Corporation	10nm	12000mm	3000mm	8m/s
	1nm	±1800mm *	±1500mm *	3.6m/s

* When the center of the effective length is set zero (ORIGIN) at default setting. When zero-set is executed at the edge of the scale, the maximum effective length will change.

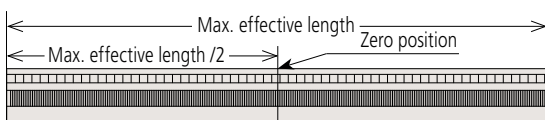

Effective length

(Double-end fixation): -2100 mm - +2100 mm
(Mitutoyo ENSIS, Mitsubishi Electric Corporation,
FANUC Ltd., Panasonic Corporation)
-1800 mm - +1800 mm
(Yaskawa Electric Corporation)
(Double-stick tape fixation): -1500 mm - +1500 mm

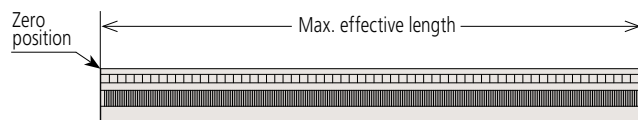

Effective length

(Double-end fixation/Double-stick tape fixation):
0 mm - +2100 mm
(Mitutoyo ENSIS, Mitsubishi Electric Corporation,
FANUC Ltd., Panasonic Corporation)
0 mm - +1800 mm
(Yaskawa Electric Corporation)

Output specification

Compatible connector
HDAB-15S
(Standard accessory)

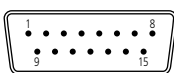

Pin assignment for Mitsubishi Electric Corporation MELSERVO

Pin No.	Signal	Pin No.	Signal
1, 2	0V (LG)	10	N.C
3, 4	+5V (P5)	11	+5V (P5)
5	N.C	12	N.C
6	N.C	13	0V (LG)
7	MR (RQ/DT)	14	N.C
8	MRR (RQ/DT)	15	F.G
9	N.C	Connector shell	F.G

Pin assignment for Panasonic Corporation MINAS

Pin No.	Signal	Pin No.	Signal
1, 2	GND	10	N.C
3, 4	+5V	11	+5V
5	N.C	12	N.C
6	N.C	13	GND
7	+REQ/+SD	14	N.C
8	-REQ/-SD	15	F.G
9	N.C	Connector shell	F.G

Pin assignment for FANUC Ltd. a/a i

Pin No.	Signal	Pin No.	Signal
1, 2	GND	10	N.C
3, 4	+5V	11	+5V
5	SD or SD/REQ	12	N.C
6	_SD or _SD/REQ	13	GND
7*	REQ or TEST	14	N.C
8*	_REQ or _TEST	15	F.G
9	N.C	Connector shell	F.G

* TEST/_TEST signal: Used as a communication line when checking signal.

Pin assignment for Yaskawa Electric Corporation Σ Series

Pin No.	Signal	Pin No.	Signal
1, 2	GND	10	N.C
3, 4	VCC	11	VCC
5	N.C	12	N.C
6	N.C	13	GND
7	S	14	N.C
8	/S	15	F.G
9	N.C	Connector shell	F.G

External View

- Double-end fixation type (Effective length: 500 to 1000mm)

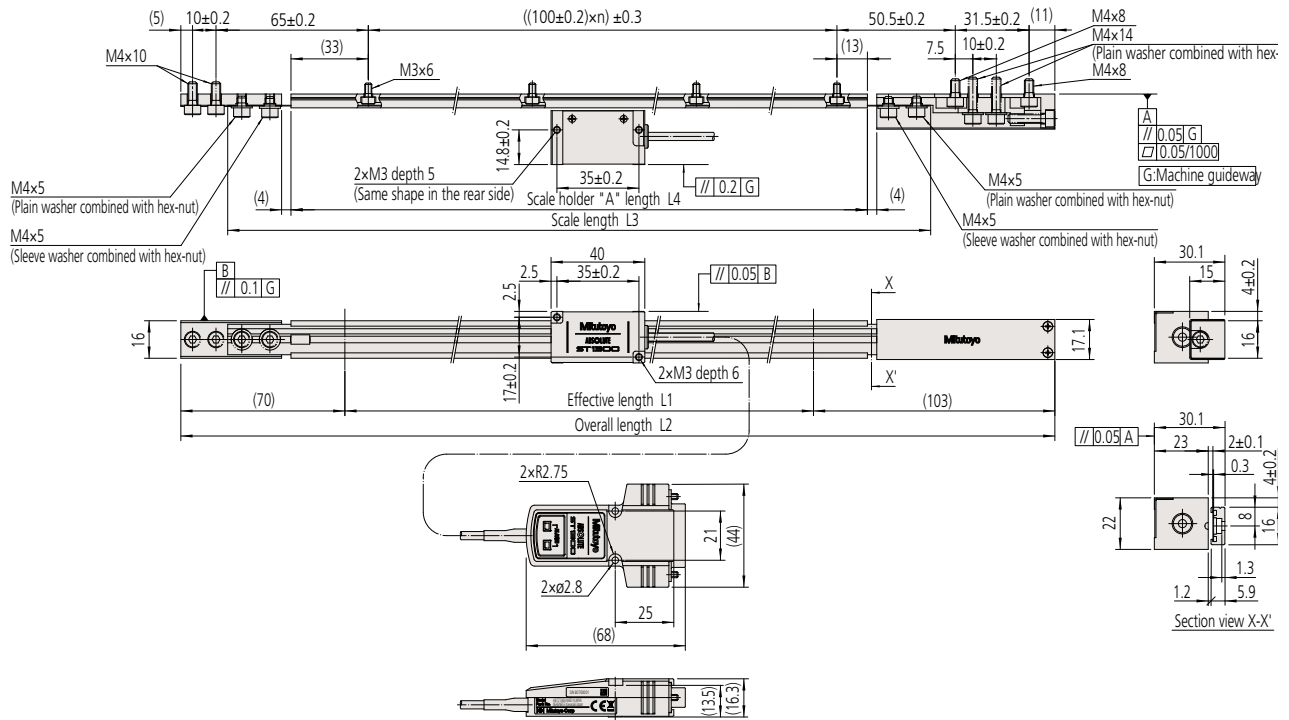

Dimensions

- Resolution: 0.01 μ m

Order No.	Code	Effective length L1 (mm)	Scale length L2 (mm)	Scale length L3 (mm)	Scale holder A L4 (mm)	No. of mounting holes	Mass (g)
579-434-□1	ST13◇1A-00500D	500	673	600	546	5	513
579-435-□1	ST13◇1A-00600D	600	773	700	646	6	534
579-436-□1	ST13◇1A-00700D	700	873	800	746	7	556
579-437-□1	ST13◇1A-00800D	800	973	900	846	8	578
579-438-□1	ST13◇1A-00900D	900	1073	1000	946	9	599
579-439-□1	ST13◇1A-01000D	1000	1173	1100	1046	10	621

Dimensions

- Resolution: 0.001 μ m

Order No.	Code	Effective length L1 (mm)	Scale length L2 (mm)	Scale length L3 (mm)	Scale holder A L4 (mm)	No. of mounting holes	Mass (g)
579-434-□2	ST13◇2A-00500D	500	673	600	546	5	513
579-435-□2	ST13◇2A-00600D	600	773	700	646	6	534
579-436-□2	ST13◇2A-00700D	700	873	800	746	7	556
579-437-□2	ST13◇2A-00800D	800	973	900	846	8	578
579-438-□2	ST13◇2A-00900D	900	1073	1000	946	9	599
579-439-□2	ST13◇2A-01000D	1000	1173	1100	1046	10	621

□ indicates the interface specification (0,4,5,7,8).
 ◇ indicates the interface specification (0,4,5,7,8).

External View

- Double-end fixation type (Effective length: 1100 to 12000mm)

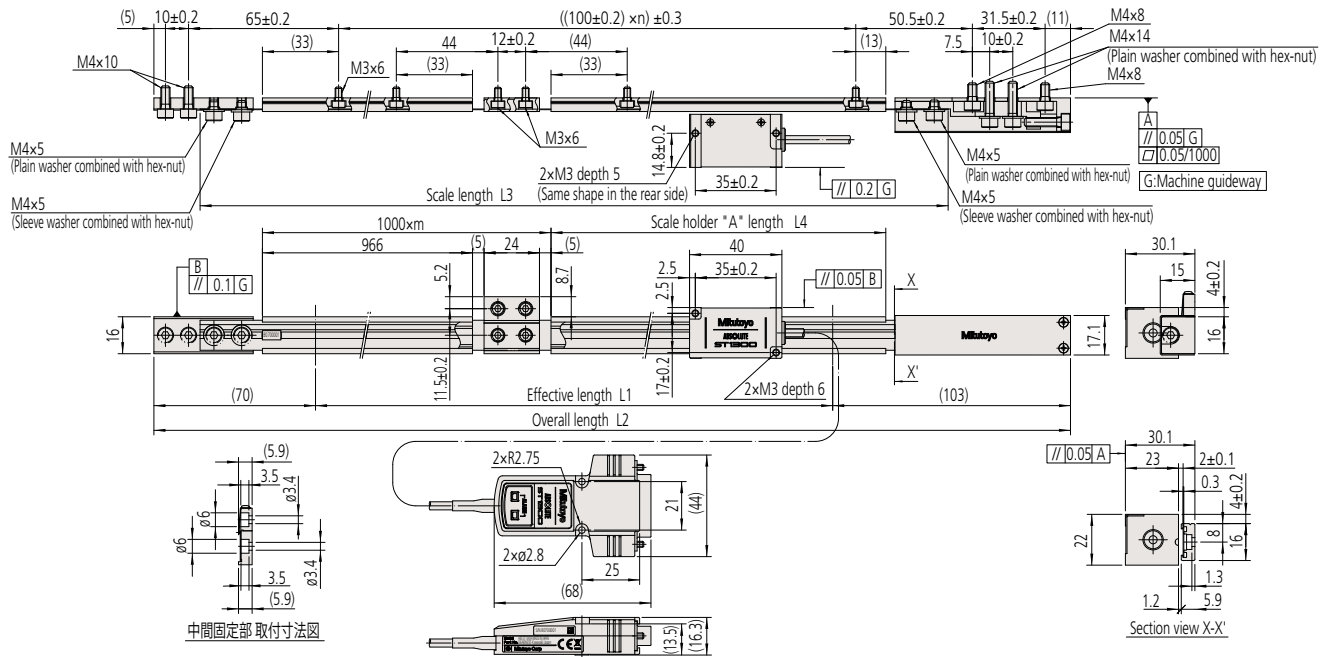

Dimensions

- Resolution: 0.01μm

Order No.	Code	Effective length L1 (mm)	Scale length L2 (mm)	Scale length L3 (mm)	Scale holder A L4 (mm)	No. of mounting holes	Mass (g)
579-440-1	ST13◇1A-01100D	1100	1273	1200	146	11	659
579-441-1	ST13◇1A-01200D	1200	1373	1300	246	12	680
579-442-1	ST13◇1A-01300D	1300	1473	1400	346	13	702
579-443-1	ST13◇1A-01400D	1400	1573	1500	446	14	724
579-444-1	ST13◇1A-01500D	1500	1673	1600	546	15	745
579-445-1	ST13◇1A-01600D	1600	1773	1700	646	16	767
579-446-1	ST13◇1A-01700D	1700	1873	1800	746	17	788
579-447-1	ST13◇1A-01800D	1800	1973	1900	846	18	810
579-448-1	ST13◇1A-02000D	2000	2173	2100	1046	20	853
579-449-1	ST13◇1A-02200D	2200	2373	2300	246	22	913
579-450-1	ST13◇1A-02400D	2400	2573	2500	446	24	956
579-451-1	ST13◇1A-02500D	2500	2673	2600	546	25	977
579-452-1	ST13◇1A-02600D	2600	2773	2700	646	26	999
579-453-1	ST13◇1A-02800D	2800	2973	2800	846	28	1042
579-454-1	ST13◇1A-03000D	3000	3173	3100	1046	30	1085
579-455-1	ST13◇1A-03200D	3200	3373	3300	246	32	1145
579-456-1	ST13◇1A-03400D	3400	3573	3500	446	34	1188
579-457-1	ST13◇1A-03600D	3600	3773	3700	646	36	1231
579-458-1	ST13◇1A-03800D	3800	3973	3900	846	38	1274
579-459-1	ST13◇1A-04000D	4000	4173	4100	1046	40	1318
579-460-1	ST13◇1A-04200D	4200	4373	4300	246	42	1377
579-461-1	ST13◇1A-04400D	4400	4573	4500	446	44	1420
579-462-1	ST13◇1A-04600D	4600	4773	4700	646	46	1463
579-463-1	ST13◇1A-04800D	4800	4973	4900	846	48	1507
579-464-1	ST13◇1A-05000D	5000	5173	5100	1046	50	1550
579-465-1	ST13◇1A-05200D	5200	5373	5300	246	52	1609
579-466-1	ST13◇1A-05400D	5400	5573	5500	446	54	1652
579-467-1	ST13◇1A-05600D	5600	5773	5700	646	56	1696
579-468-1	ST13◇1A-05800D	5800	5973	5900	846	58	1739
579-469-1	ST13◇1A-06000D	6000	6173	6100	1046	60	1782
579-470-1	ST13◇1A-06200D	6200	6373	6300	246	62	1841
579-471-1	ST13◇1A-06400D	6400	6573	6500	446	64	1885
579-472-1	ST13◇1A-06600D	6600	6773	6700	646	66	1928
579-473-1	ST13◇1A-06800D	6800	6973	6900	846	68	1971
579-474-1	ST13◇1A-07000D	7000	7173	7100	1046	70	2014
579-475-1	ST13◇1A-07200D	7200	7373	7300	246	72	2074
579-476-1	ST13◇1A-07400D	7400	7573	7500	446	74	2117
579-477-1	ST13◇1A-07600D	7600	7773	7700	646	76	2160
579-478-1	ST13◇1A-07800D	7800	7973	7900	846	78	2203
579-479-1	ST13◇1A-08000D	8000	8173	8100	1046	80	2246
579-480-1	ST13◇1A-08200D	8200	8373	8300	246	82	2306
579-481-1	ST13◇1A-08400D	8400	8573	8500	446	84	2349
579-482-1	ST13◇1A-08600D	8600	8773	8700	646	86	2392
579-483-1	ST13◇1A-08800D	8800	8973	8900	846	88	2435
579-484-1	ST13◇1A-09000D	9000	9173	9100	1046	90	2479

Order No.	Code	Effective length L1 (mm)	Scale length L2 (mm)	Scale length L3 (mm)	Scale holder A L4 (mm)	No. of mounting holes	Mass (g)
579-485-1	ST13◇1A-09200D	9200	9373	9300	246	92	2538
579-486-1	ST13◇1A-09400D	9400	9573	9500	446	94	2581
579-487-1	ST13◇1A-09600D	9600	9773	9700	646	96	2625
579-488-1	ST13◇1A-09800D	9800	9973	9900	846	98	2668
579-489-1	ST13◇1A-10000D	10000	10173	10100	1046	100	2711
579-490-1	ST13◇1A-10200D	10200	10373	10300	246	102	2770
579-491-1	ST13◇1A-10400D	10400	10573	10500	446	104	2814
579-492-1	ST13◇1A-10600D	10600	10773	10700	646	106	2857
579-493-1	ST13◇1A-10800D	10800	10973	10900	846	108	2900
579-494-1	ST13◇1A-11000D	11000	11173	11100	1046	110	2943
579-495-1	ST13◇1A-11200D	11200	11373	11300	246	112	3003
579-496-1	ST13◇1A-11400D	11400	11573	11500	446	114	3046
579-497-1	ST13◇1A-11600D	11600	11773	11700	646	116	3089
579-498-1	ST13◇1A-11800D	11800	11973	11900	846	118	3132
579-499-1	ST13◇1A-12000D	12000	12173	12100	1046	120	3175

Dimensions

- Resolution: 0.001μm

Order No.	Code	Effective length L1 (mm)	Scale length L2 (mm)	Scale length L3 (mm)	Scale holder A L4 (mm)	No. of mounting holes	Mass (g)
579-440-2	ST13◇2A-01100D	1100	1273	1200	146	11	659
579-441-2	ST13◇2A-01200D	1200	1373	1300	246	12	680
579-442-2	ST13◇2A-01300D	1300	1473	1400	346	13	702
579-443-2	ST13◇2A-01400D	1400	1573	1500	446	14	724
579-444-2	ST13◇2A-01500D	1500	1673	1600	546	15	745
579-445-2	ST13◇2A-01600D	1600	1773	1700	646	16	767
579-446-2	ST13◇2A-01700D	1700	1873	1800	746	17	788
579-447-2	ST13◇2A-01800D	1800	1973	1900	846	18	810
579-448-2	ST13◇2A-02000D	2000	2173	2100	1046	20	853
579-449-2	ST13◇2A-02200D	2200	2373	2300	246	22	913
579-450-2	ST13◇2A-02400D	2400	2573	2500	446	24	956
579-451-2	ST13◇2A-02500D	2500	2673	2600	546	25	977
579-452-2	ST13◇2A-02600D	2600	2773	2700	646	26	999
579-453-2	ST13◇2A-02800D	2800	2973	2900	846	28	1042
579-454-2	ST13◇2A-03000D	3000	3173	3100	1046	30	1085
579-455-2	ST13◇2A-03200D	3200	3373	3300	246	32	1145
579-456-2	ST13◇2A-03400D	3400	3573	3500	446	34	1188
579-457-2	ST13◇2A-03600D	3600	3773	3700	646	36	1231
579-458-2	ST13◇2A-03800D	3800	3973	3900	846	38	1274
579-459-2	ST13◇2A-04000D	4000	4173	4100	1046	40	1318
579-460-2	ST13◇2A-04200D	4200	4373	4300	246	42	1377

□ indicates the interface specification (0,4,5,7,8).
 ◇ indicates the interface specification (0,4,5,7,8).
 Effective length of ST1382A is up to 3600mm.

External View

- Double-end fixation type (Effective length: 10 to 3000mm)

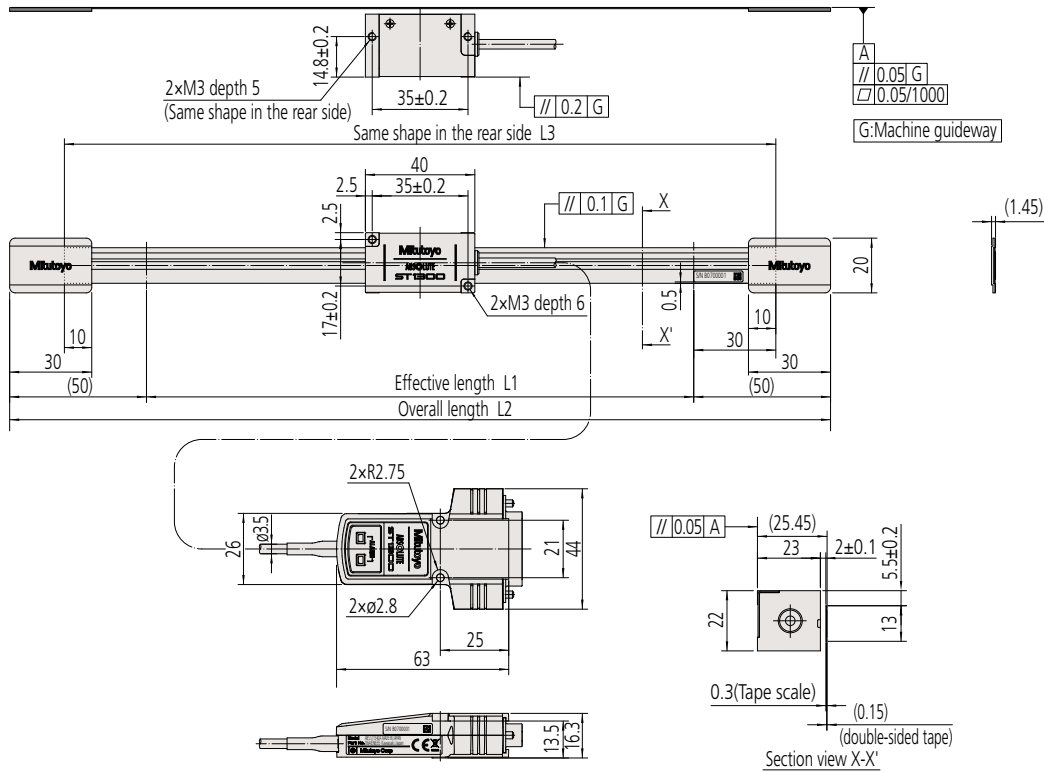

Dimensions

- Resolution: 0.01µm

Order No.	Code	Effective length L1 (mm)	Scale length L2 (mm)	Scale length L3 (mm)	Mass (g)
579-401-1	ST13◇1A-00010E	10	110	70	300
579-402-1	ST13◇1A-00025E	25	125	85	300
579-403-1	ST13◇1A-00050E	50	150	110	301
579-404-1	ST13◇1A-00075E	75	175	135	302
579-405-1	ST13◇1A-00100E	100	200	160	303
579-406-1	ST13◇1A-00150E	150	250	210	305
579-407-1	ST13◇1A-00200E	200	300	260	307
579-408-1	ST13◇1A-00250E	250	350	310	309
579-409-1	ST13◇1A-00300E	300	400	360	311
579-410-1	ST13◇1A-00350E	350	450	410	313
579-411-1	ST13◇1A-00400E	400	500	460	315
579-412-1	ST13◇1A-00450E	450	550	510	317
579-413-1	ST13◇1A-00500E	500	600	560	319
579-414-1	ST13◇1A-00600E	600	700	660	323
579-415-1	ST13◇1A-00700E	700	800	760	327
579-416-1	ST13◇1A-00800E	800	900	860	331
579-417-1	ST13◇1A-00900E	900	1000	960	335
579-418-1	ST13◇1A-01000E	1000	1100	1060	339
579-419-1	ST13◇1A-01100E	1100	1200	1160	343
579-420-1	ST13◇1A-01200E	1200	1300	1260	346
579-421-1	ST13◇1A-01300E	1300	1400	1360	350
579-422-1	ST13◇1A-01400E	1400	1500	1460	354
579-423-1	ST13◇1A-01500E	1500	1600	1560	358
579-424-1	ST13◇1A-01600E	1600	1700	1660	362
579-425-1	ST13◇1A-01700E	1700	1800	1760	366
579-426-1	ST13◇1A-01800E	1800	1900	1860	370
579-427-1	ST13◇1A-02000E	2000	2200	2060	378
579-428-1	ST13◇1A-02200E	2200	2400	2260	386
579-429-1	ST13◇1A-02400E	2400	2500	2460	394
579-430-1	ST13◇1A-02500E	2500	2600	2560	398
579-431-1	ST13◇1A-02600E	2600	2800	2660	402
579-432-1	ST13◇1A-02800E	2800	3000	2860	409
579-433-1	ST13◇1A-03000E	3000	3100	3060	417

Dimensions









- Resolution: 0.001µm

Order No.	Code	Effective length L1 (mm)	Scale length L2 (mm)	Scale length L3 (mm)	Mass (g)
579-401-2	ST13◇2A-00010E	10	110	70	300
579-402-2	ST13◇2A-00025E	25	125	85	300
579-403-2	ST13◇2A-00050E	50	150	110	301
579-404-2	ST13◇2A-00075E	75	175	135	302
579-405-2	ST13◇2A-00100E	100	200	160	303
579-406-2	ST13◇2A-00150E	150	250	210	305
579-407-2	ST13◇2A-00200E	200	300	260	307
579-408-2	ST13◇2A-00250E	250	350	310	309
579-409-2	ST13◇2A-00300E	300	400	360	311
579-410-2	ST13◇2A-00350E	350	450	410	313
579-411-2	ST13◇2A-00400E	400	500	460	315
579-412-2	ST13◇2A-00450E	450	550	510	317
579-413-2	ST13◇2A-00500E	500	600	560	319
579-414-2	ST13◇2A-00600E	600	700	660	323
579-415-2	ST13◇2A-00700E	700	800	760	327
579-416-2	ST13◇2A-00800E	800	900	860	331
579-417-2	ST13◇2A-00900E	900	1000	960	335
579-418-2	ST13◇2A-01000E	1000	1100	1060	339
579-419-2	ST13◇2A-01100E	1100	1200	1160	343
579-420-2	ST13◇2A-01200E	1200	1300	1260	346
579-421-2	ST13◇2A-01300E	1300	1400	1360	350
579-422-2	ST13◇2A-01400E	1400	1500	1460	354
579-423-2	ST13◇2A-01500E	1500	1600	1560	358
579-424-2	ST13◇2A-01600E	1600	1700	1660	362
579-425-2	ST13◇2A-01700E	1700	1800	1760	366
579-426-2	ST13◇2A-01800E	1800	1900	1860	370
579-427-2	ST13◇2A-02000E	2000	2100	2060	378
579-428-2	ST13◇2A-02200E	2200	2400	2260	386
579-429-2	ST13◇2A-02400E	2400	2500	2460	394
579-430-2	ST13◇2A-02500E	2500	2600	2560	398
579-431-2	ST13◇2A-02600E	2600	2800	2660	402
579-432-2	ST13◇2A-02800E	2800	3000	2860	409
579-433-2	ST13◇2A-03000E	3000	3100	3060	417

□ indicates the interface specification (0,4,5,7,8).
◇ indicates the interface specification (0,4,5,7,8).

ABS ST1300 Signal Verification Program

- When the ST1300 signal verification program has been installed in a PC, the program allows signal verification and maintenance work of the scale by connecting the conversion unit and the PC to the ABS ST1300 series. (The signal verification work is indispensable. For details, refer to the User's Manual.)
- Description of signal verification program

Item	Description	Screen photo
(1) Verification of the detector head mounting position	Allows checking and judgment of the mounting status by acquiring data from the tape scale.	
(2) Verification of the total length of the tape scale	Allows checking and judgment of the mounting status by acquiring data on the total length of the tape scale.	
(3) Setting the scale origin	Allows the scale origin (positional data: 0) to be set at an arbitrary point on the scale.	
(4) Verification of the absolute position data	Allows verification of the current position data with reference to the scale origin, and the alarm code and alarm information is output attached to the position data.	
(5) Clearing error records	Allows records of error detection in the scale to be cleared.	
(6) Writing system parameters	Allows system parameters to be written to the detector head.	
(7) Reading system parameters	Allows system parameters stored in the detector head to be read out and displayed.	
(8) Reading and storing error records	Allows readout of a detailed internal error code, verification of error code information and saving error codes as an error record file in the PC.	
(9) Signal monitor	Allows a check of the acquired data over the total length of the tape scale.	

• Connection details

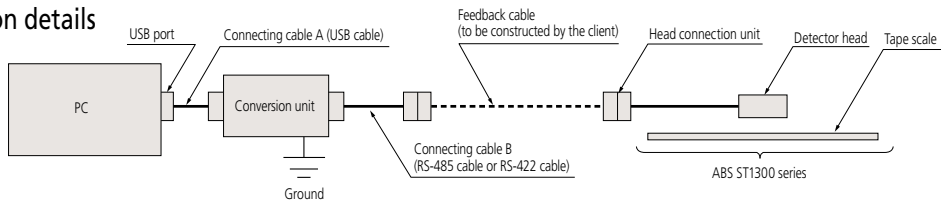

Note: To avoid the risk of electric shock, all exposed metalwork in the system must be grounded.

• Order No. of "conversion unit and signal verification program" set

Order No.	Conversion unit + Accessories	Connecting cable B
06AEX139	Signal verification program Conversion unit USB-485 DS15P	MEL-J3 cable (Mitsubishi Electric Corporation)
06AEX140	Conversion unit manual Device driver (CD-ROM)	Y/MAT cable (Yaskawa Electric Corporation)
06AFA406	Conversion unit USB device Installation manual	MIT cable (Nikki Denso)
06AFA407	Connecting cable A (USB cable) Connecting cable B	FANUC cable

Note: An Order No. is applicable to each company's interface because connecting cable B differs depending on the interface of the ABS ST1300 series.

Assembly Type ABS AT Series

Absolute Scale Unit (Standard Type)

DRIVE-CLIQ

ABS AT1100 Series

(Resolution 0.05 μ m Specification)



ABSOLUTE™

Features

- This series has adopted a new structure not easily subject to infiltration of coolant and a dust-proof rubber highly resistant to coolant attack. It offers a field support type linear scale with higher reliability than before.
- The sensor-to-scale air gap in this newly developed implementation of Mitutoyo's unique electromagnetic induction method is approximately 0.4mm – around 4 times as wide as that of a conventional optical or electromagnetic sensor. This much larger gap makes problems due to the ingress of foreign bodies, etc. unlikely to occur, and is the world's largest in a machine tool-oriented scale.
- The de facto standard frame multipoint mounting method has been adopted to provide high resistance to vibration and shock.
- The improvement of signal processing technology in the electromagnetic induction type absolute linear encoder has achieved approximately 6 times higher accuracy than that of previous scales.
- This series is compatible with the high-speed serial interface from leading machine-tool companies, allowing direct connection to an NC controller.

Meaning of Model No.

ABS AT11□□3 - □□□□
Effective length

Interface specifications

Applicable system	Scale model
FANUC Ltd., Serial α i interface	ABS AT1153
Mitsubishi Electric Corporation, High-speed serial interface	ABS AT1143
Siemens AG, DRIVE-CLIQ	ABS AT1123

Note: For the details of applicable systems, inquiries should be made of each manufacturer.

Scale configuration

[ABS AT1100 Series]

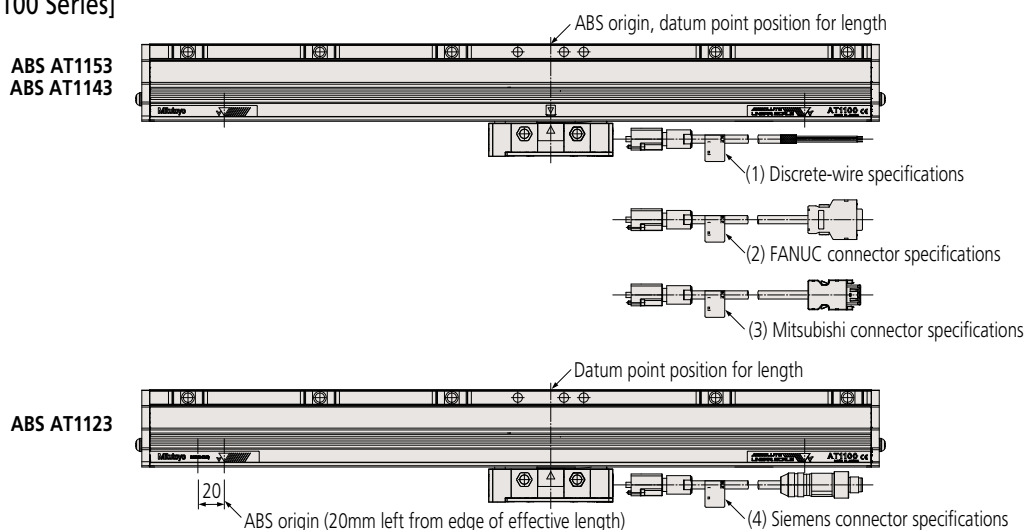

Mitutoyo

Specifications

Items	Model	ABS AT11□3
Detection method		Electromagnetic induction
Mounting method		Frame multipoint
Reference position for expansion due to temperature variation		Refer to the External View diagram (L5)
Detection method	24 types: 140,240,340,440,540,640,740,840,940,1040,1140,1240,1340,1440,1540,1640,1740,1840,2040,2240,2440,2640,2840,3040	
Resolution		0.05μm
Maximum response speed		3m/sec
Indication accuracy (20°C)		Effective length $L_0=140-2040\text{mm}$: $3+5L_0/1000$ (μm) Effective length $L_0=2240-3040\text{mm}$: $5+5L_0/1000$ (μm)
Expansion coefficient		$\approx 8 \times 10^{-6} / \text{K}$
Vibration resistance		$\leq 196\text{m/s}^2$ (20G) (55 - 2000Hz)
Shock resistance		Effective length $L_0=140-2040\text{mm}$: $\leq 343\text{m/s}^2$ (35G) Effective length $L_0=2240-3040\text{mm}$: $\leq 294\text{m/s}^2$ (30G) (1/2sin 11ms)
Power supply voltage		ABS AT1153/1143: DC5V±10% ABS AT1123: DC24V (Conforming to DRIVE-CLiQ)
Maximum current consumption		AT1153: 300mA (Max) AT1143: 290mA (Max) AT1123: 140mA (Max)
Operational temperature/humidity ranges		0 to 50°C 20 to 80%RH (non-condensing)
Storage temperature/humidity ranges		-20 to 70°C 20 to 80%RH (non-condensing)

System Configuration (Example)

[ABS AT1153/AT1143]

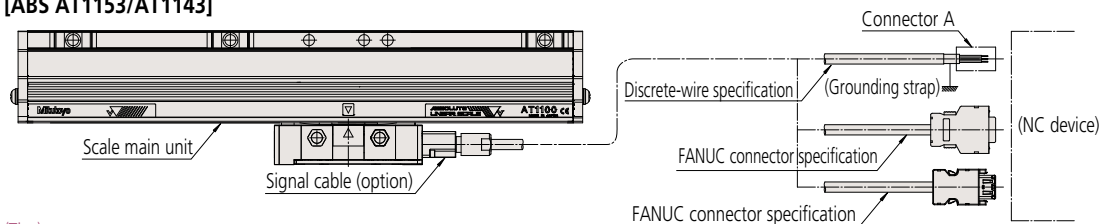

(Tips)

1. The signal cable is an option. The client should construct this according to the situation.
2. The client should configure connector A according to the situation.
3. Installation of connector A and the grounding strap is the responsibility of the client.

[ABS AT1123]

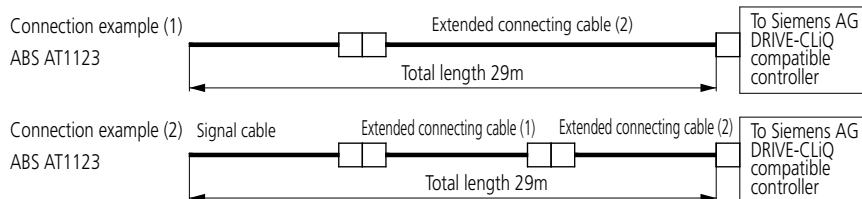
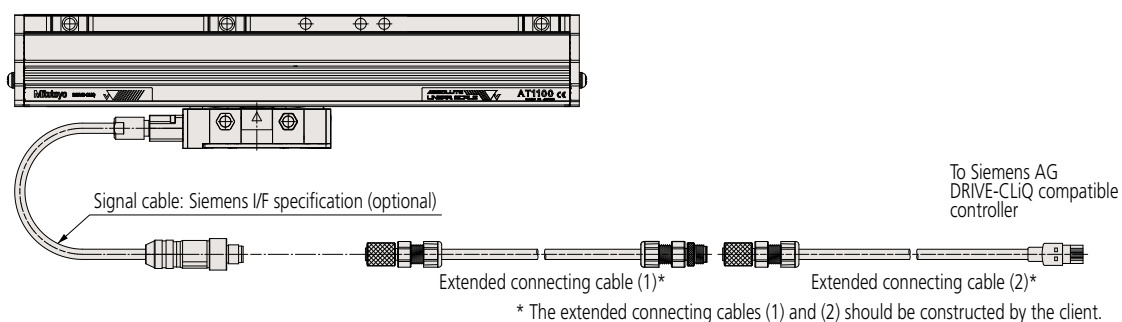

- Extended connecting cable (1) SIEMENS AG Model No. 6FX8002-2DC34 - □ □ □ □
- Extended connecting cable (2) SIEMENS AG Model No. 6FX8002-2DC30 - □ □ □ □

(NOTE)

1. The extended connecting cable(s) should be constructed by the client.
2. Keep the total length of signal cable and extended connecting cable(s) less than 29m.
3. For the signal cable specification and how to obtain, contact Siemens AG.

Output specifications

• ABS AT1153/1143 (discrete-wire)

Wire color	Signal
Brown	SD
Red	*SD
Orange	RQ (REQ)
Yellow	*RQ (REQ)
White (2P)	+5V
Black (2P)	GND
Shield wire	F.G

* Cable to be constructed by the client (A total of 29 meters with the signal cable).

• ABS AT1153

FANUC connector specifications (FI-20)

Pin No.	Signal
1	SD
2	*SD
5	RQ(REQ)
6	*RQ(REQ)
12.14	GND
18.20	+5V
16	F.G
3.4.7. - 13.15.17.19	Not used

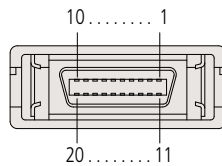

• ABS AT1143

Mitsubishi connector specifications (MDR)

Pin No.	Signal
1	5V
2	GND
3	RQDT
4	RQDT̄
7	DT
8	DT̄
5.6.9.10	Not used
Connector shell	F.G

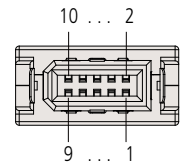

• ABS AT1123 (discrete-wire)

Siemens connector specifications

Wire color	Signal
White/Brown	+24V
Brown	GND
White/Blue	TEST
Blue	TEST̄
White/Orange	TXP
Orange	TXN
White/Green	RXP
Green	RXN
Shield	F.G

Note: Leave test terminals (TEST, TEST̄) disconnected during use.

• ABS AT1123

M12 connector specifications

Pin No.	Signal
1	+24V
2	TEST
3	RXP
4	RXN
5	GND
6	TXN
7	TXP
8	TEST̄
Shield sleeve	F.G

Note: Leave test terminals (TEST, TEST̄) disconnected during use.

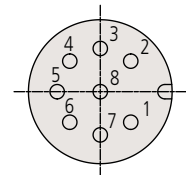

Cable Dimensions

Unit: mm

• ABS AT1153/1143 (discrete-wire specification)

Detector head (custom) side: Waterproof

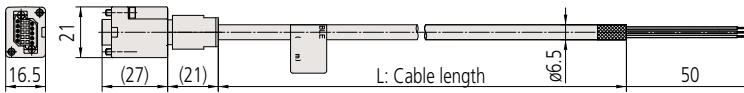

Code No.	Model	Cable length (m)
06AFG596-1	AT1100F/M discrete-wire cable 1m	1
06AFG596-3	AT1100F/M discrete-wire cable 3m	3
06AFG596-6	AT1100F/M discrete-wire cable 6m	6
06AFG596-9	AT1100F/M discrete-wire cable 9m	9
06AFG596-12	AT1100F/M discrete-wire cable 12m	12

* Discrete-wire cable can not be used for ABS AT1123 (SIEMENS I/F).

• ABS AT1153 (FANUC connector specifications)

Detector head (custom) side: Waterproof

NC (FI-20) side: Non-waterproof

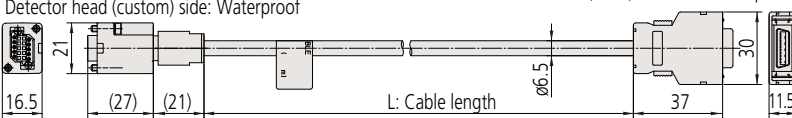

Code No.	Model	Cable length (m)
06AFF921-1	AT1100F Cable FUNUC 1m	1
06AFF921-3	AT1100F Cable FUNUC 3m	3
06AFF921-6	AT1100F Cable FUNUC 6m	6
06AFF921-9	AT1100F Cable FUNUC 9m	9

• ABS AT1143 (Mitsubishi connector specifications)

Detector head (custom) side: Waterproof

NC (MDR) side: Non-waterproof

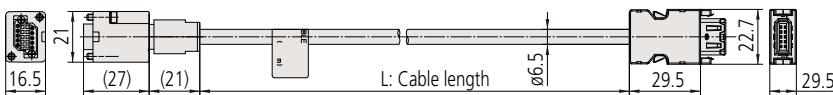

Code No.	Model	Cable length (m)
06AFF957-1	AT1100M Cable MDS-D 1m	1
06AFF957-3	AT1100M Cable MDS-D 3m	3
06AFF957-6	AT1100M Cable MDS-D 3m	6
06AFF957-9	AT1100M Cable MDS-D 9m	9

• ABS AT1123 (discrete-wire specification)

Detector head (custom) side: Waterproof

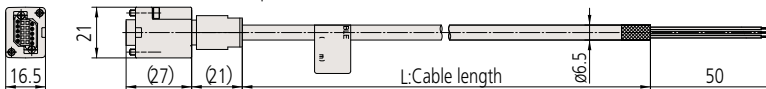

Code No.	Model	Cable length (m)
06AFM103-1	AT1100S discrete-wire cable 1m	1
06AFM103-3	AT1100S discrete-wire cable 3m	3
06AFM103-6	AT1100S discrete-wire cable 3m	6
06AFM103-9	AT1100S discrete-wire cable 3m	9
06AFM103-12	AT1100S discrete-wire cable 9m	12

• ABS AT1123 (M12 connector specifications)

Detector head (custom) side: Waterproof

NC (M12) side: Non-waterproof

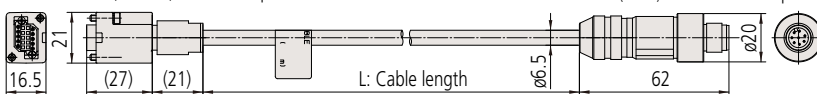

Code No.	Model	Cable length (m)
06AFL121-1	AT1100S Cable M12 1m	1
06AFL121-3	AT1100S Cable M12 3m	3
06AFL121-6	AT1100S Cable M12 6m	6
06AFL121-9	AT1100S Cable M12 9m	9

External View

• ABS AT1153/AT1143

Unit: mm

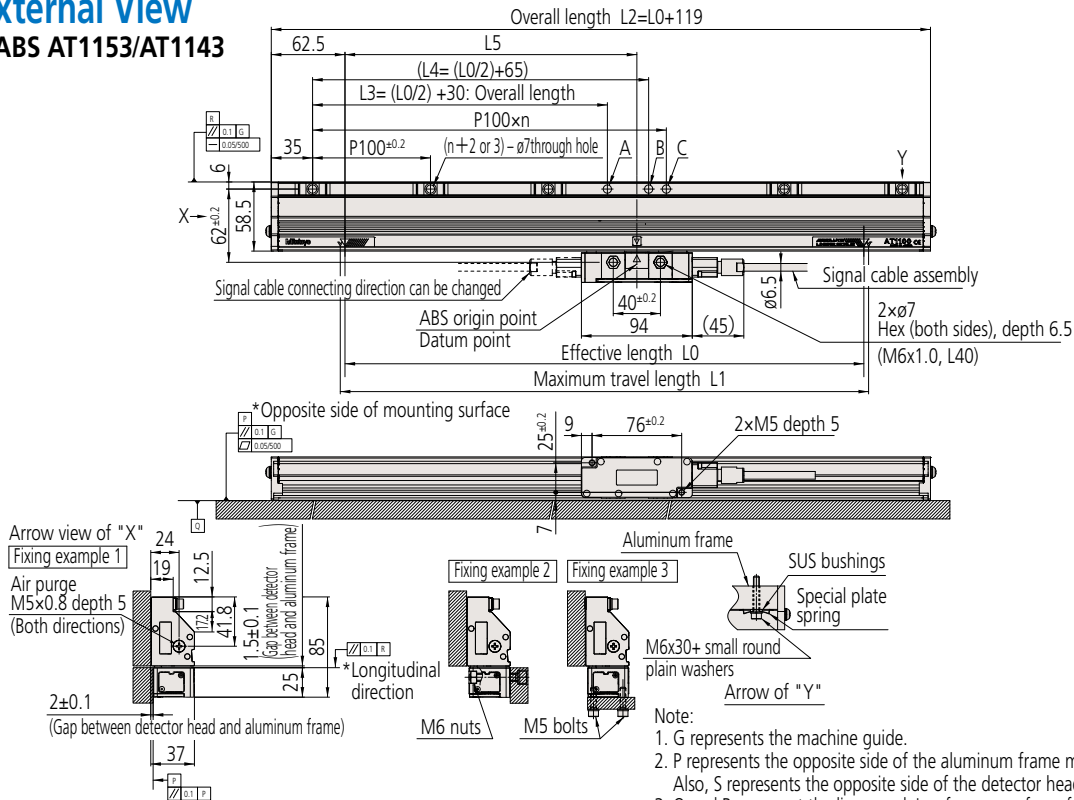

Dimensions

Order No.	Model	Effective length	Maximum travel length	Overall length	Mounting pitch			No. of mounting holes
		L_0 (mm)	L_1 (mm)	L_2 (mm)	L_3 (mm)	L_4 (mm)	L_5 (mm)	
559-100-□3	AT11□3-140	140	148	259	100	135	90	2
559-101-□3	AT11□3-240	240	248	359	150	185	147.5	3
559-102-□3	AT11□3-340	340	348	459	200	235	190	4
559-103-□3	AT11□3-440	440	448	559	250	285	247.5	5
559-104-□3	AT11□3-540	540	548	659	300	335	290	6
559-105-□3	AT11□3-640	640	648	759	350	385	347.5	7
559-106-□3	AT11□3-740	740	748	859	400	435	390	8
559-107-□3	AT11□3-840	840	848	959	450	485	447.5	9
559-108-□3	AT11□3-940	940	948	1059	500	535	490	10
559-109-□3	AT11□3-1040	1040	1048	1159	550	585	547.5	11
559-110-□3	AT11□3-1140	1140	1148	1259	600	635	590	12
559-111-□3	AT11□3-1240	1240	1248	1359	650	685	647.5	13
559-112-□3	AT11□3-1340	1340	1348	1459	700	735	690	14
559-113-□3	AT11□3-1440	1440	1448	1559	750	785	747.5	15
559-114-□3	AT11□3-1540	1540	1548	1659	800	835	790	16
559-115-□3	AT11□3-1640	1640	1648	1759	850	885	847.5	17
559-116-□3	AT11□3-1740	1740	1748	1859	900	935	890	18
559-117-□3	AT11□3-1840	1840	1848	1959	950	985	947.5	19
559-118-□3	AT11□3-2040	2040	2048	2159	1050	1085	1047.5	21
559-119-□3	AT11□3-2240	2240	2248	2359	1150	1185	1147.5	23
559-120-□3	AT11□3-2440	2440	2448	2559	1250	1285	1247.5	25
559-121-□3	AT11□3-2640	2640	2648	2759	1350	1385	1347.5	27
559-122-□3	AT11□3-2840	2840	2848	2959	1450	1485	1447.5	29
559-123-□3	AT11□3-3040	3040	3048	3159	1550	1585	1547.5	31

* □ in Order No. and Model indicates the interface specification as follows:
 AT1143: 4
 AT1153: 5

External View

• ABS AT1123

Unit: mm

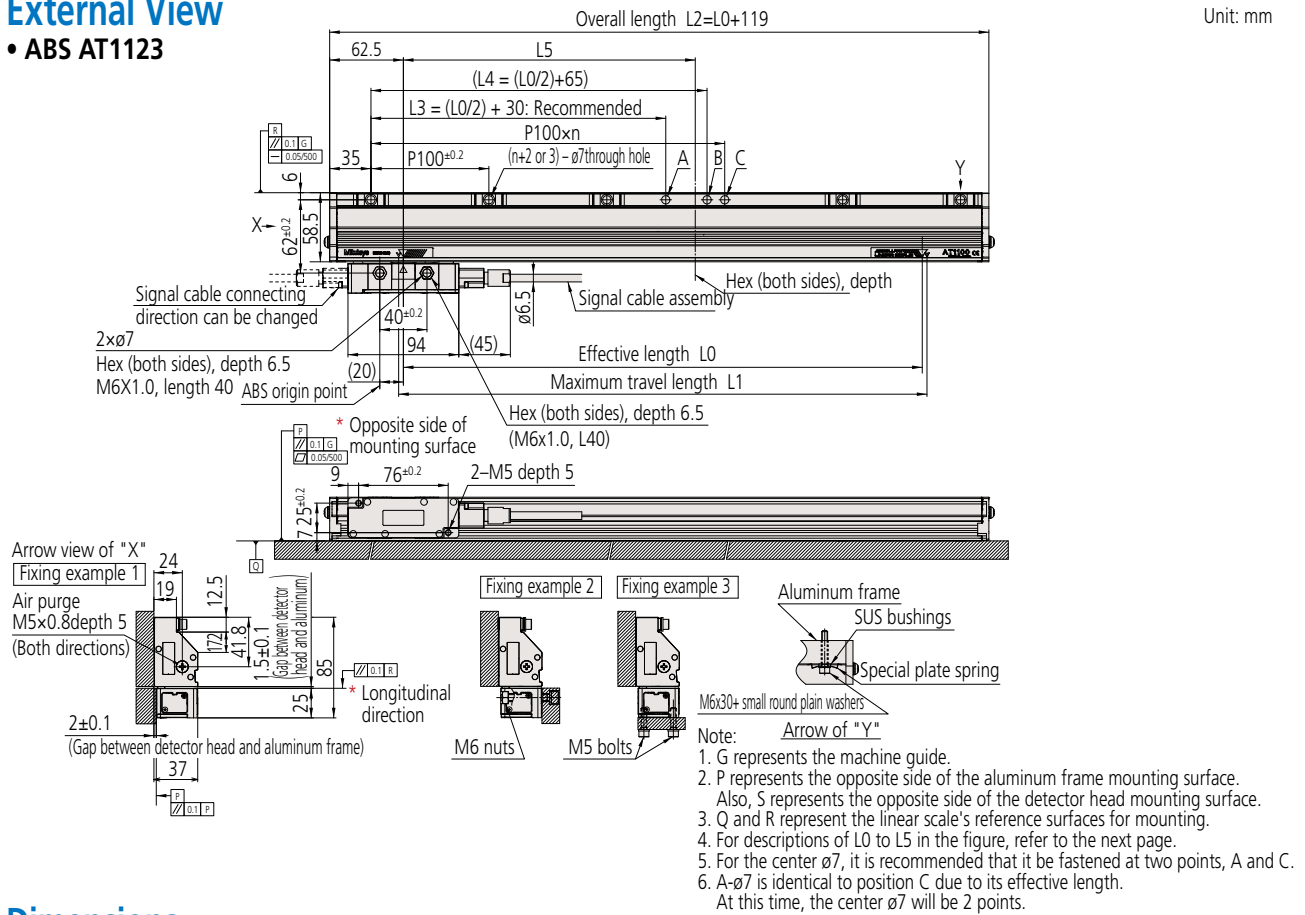

Dimensions

Order No.	Model	Effective length	Maximum travel length	Overall length	Mounting pitch			No. of mounting holes n
		L0 (mm)	L1 (mm)		L3 (mm)	L4 (mm)	L5 (mm)	
559-100-23	AT1123-140	140	148	259	100	135	90	2
559-101-23	AT1123-240	240	248	359	150	185	147.5	3
559-102-23	AT1123-340	340	348	459	200	235	190	4
559-103-23	AT1123-440	440	448	559	250	285	247.5	5
559-104-23	AT1123-540	540	548	659	300	335	290	6
559-105-23	AT1123-640	640	648	759	350	385	347.5	7
559-106-23	AT1123-740	740	748	859	400	435	390	8
559-107-23	AT1123-840	840	848	959	450	485	447.5	9
559-108-23	AT1123-940	940	948	1059	500	535	490	10
559-109-23	AT1123-1040	1040	1048	1159	550	585	547.5	11
559-110-23	AT1123-1140	1140	1148	1259	600	635	590	12
559-111-23	AT1123-1240	1240	1248	1359	650	685	647.5	13
559-112-23	AT1123-1340	1340	1348	1459	700	735	690	14
559-113-23	AT1123-1440	1440	1448	1559	750	785	747.5	15
559-114-23	AT1123-1540	1540	1548	1659	800	835	790	16
559-115-23	AT1123-1640	1640	1648	1759	850	885	847.5	17
559-116-23	AT1123-1740	1740	1748	1859	900	935	890	18
559-117-23	AT1123-1840	1840	1848	1959	950	985	947.5	19
559-118-23	AT1123-2040	2040	2048	2159	1050	1085	1047.5	21
559-119-23	AT1123-2240	2240	2248	2359	1150	1185	1147.5	23
559-120-23	AT1123-2440	2440	2448	2559	1250	1285	1247.5	25
559-121-23	AT1123-2640	2640	2648	2759	1350	1385	1347.5	27
559-122-23	AT1123-2840	2840	2848	2959	1450	1485	1447.5	29
559-123-23	AT1123-3040	3040	3048	3159	1550	1585	1547.5	31

Assembly Type ABS AT Series

Absolute Scale Unit (Slim Spar Type)

DRIVE-CLIQ

ABS AT500 Series

(Resolution 0.001 μ m/0.005 μ m/0.01 μ m)



ABS AT500-S Series

ABS AT500-H Series

Features

- This scale achieves the Absolute Linear Scale's highest level resolution of 0.001 μ m
- The ABS AT500-S Series realizes vibration resistance of 196m/s² (20G) and shock-resistance of 343m/s² (35G), suitable for use with heavy cutting equipment and for high-speed machining.
- The ABS AT500-H Series has high repeatability, excellent temperature characteristics, and enables highly accurate and stable positioning.
- Slim shape is suitable for space-saving designs.
- Compatible with servo amplifiers from a range of companies (high-speed serial interfaces).

How to read the code

ABS AT5 5 - -

Interface specification

Effective range

Applicable systems	Scale code
FANUC Ltd. control devices FS-i Series POWER Mate i	ABS AT555
Mitsubishi Electric Corporation control devices MITSUBISHI CNC Series MDS-D/MDS-DH Series	ABS AT545
Mitsubishi Electric Corporation MR-J4/MR-J3 Series	ABS AT545A
Amplifier compatible with the Mitutoyo ENSIS interface	ABS AT505 ABS AT505A
Siemens AG DRIVE-CLIQ	ABS AT524 AT527

Note: ABS AT55

Resolution

- 7: 0.001 μ m *only for AT524
- 5: 0.005 μ m (20 μ m/4096)
- 4: 0.01 μ m *only for AT524

Communication method

- Blank: Full-duplex communication
- A: Half-duplex communication
- AT524/527: DRIVE-CLIQ communication

Base position (the 'zero elongation' point)*

- C: Midpoint of effective range
- L: End of effective range (+ side end)
- R: End of effective range (- side end)

Note: L and R are only for the high-accuracy type
* This refers to the fixed point on the scale around which clamping arrangements ensure that any expansion or contraction due to temperature change occurs.

Scale unit specifications

- S: High-rigidity type
- H: High-accuracy type

Note: For details regarding the applicable system, please consult with the individual manufacturer.

Scale configuration

ABS AT500-S Series

- ABS AT55-SC
- ABS AT55A-SC
- ABS AT524-SC
- ABS AT527-SC

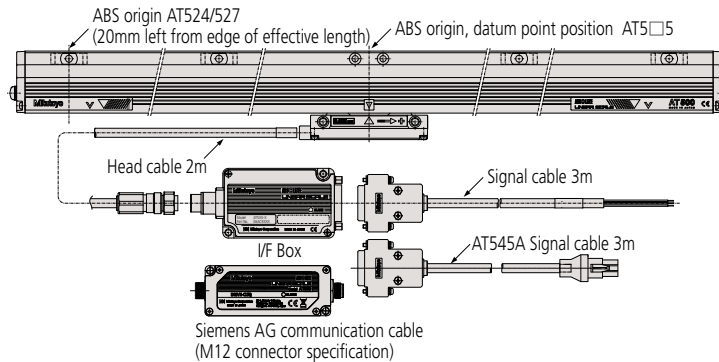

ABS AT500-H Series

- ABS AT55-HC
- ABS AT55A-HC
- ABS AT524-HC
- ABS AT527-HC

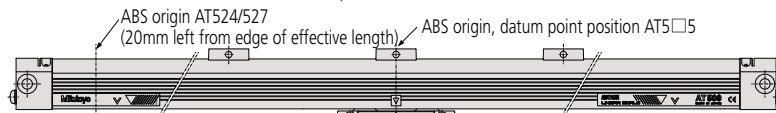

- ABS AT55-HR
- ABS AT55A-HR
- ABS AT524-HR
- ABS AT527-HR

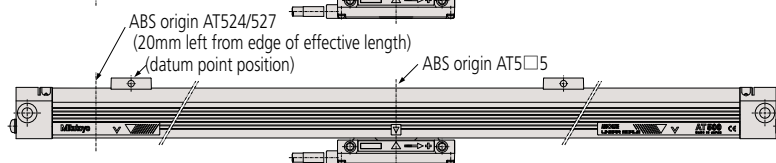

- ABS AT55-HL
- ABS AT55A-HL
- ABS AT524-HL
- ABS AT527-HL

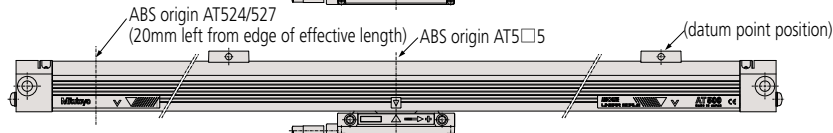

Specifications

Item	Code	High-rigidity type			High-accuracy type					
		ABS AT□□□-SC			ABS AT□□□-HC			ABS AT□□□-HL/HR		
		AT5□5/AT5□5A	AT524	AT527	AT5□5/AT5□5A	AT524	AT527	AT5□5/AT5□5A	AT524	AT527
Detection method	Electrostatic capacitance type / photoelectric type composite ABS linear encoder									
Scale mounting method	Multi-point elastic fixing			3 or 5-point elastic fixing			3 or 4-point elastic fixing			
Base position	Midpoint of effective range						End of effective range HL: (+ side of absolute value) HR: (- side of absolute value)			
Effective range	100 to 2200mm			100 to 1000mm			100 to 350mm			
Resolution	0.005μm (20μm/4096)*	0.01μm	0.001μm	0.005μm (20μm/4096)*	0.01μm	0.001μm	0.005μm (20μm/4096)*	0.01μm	0.001μm	
Maximum response speed	150m/min (2.5m/s)			72m/min (1.2m/s)						
Accuracy (20°C)	(3+3Lo/1000) μm Lo: Effective range (mm)			(2+2Lo/1000) μm Lo: Effective range (mm)						
Thermal expansion coefficient	≈ 8.5 x 10 ⁻⁶ / K									
Vibration resistance	196m/s ² (20G) (55 to 2000Hz)			147m/s ² (15G) (55 to 2000Hz)						
Shock resistance	343m/s ² (35G) (1/2sin 11ms)			196m/s ² (20G) (1/2sin 11ms)						
Power supply voltage	DC5V±5%	DC24V (Conforms to DRIVE-CLiQ)		DC5V±5%	DC24V (Conforms to DRIVE-CLiQ)		DC5V±5%	DC24V (Conforms to DRIVE-CLiQ)		
Maximum current consumption	270mA (Max)	110mA (Max)		270mA (Max)	110mA (Max)		270mA (Max)	110mA (Max)		
Maximum sliding force	4N									
Operating temperature/humidity	0 to 45°C 20 to 80%RH (no condensation)									
Storage temperature/humidity	-20 to 70°C 20 to 80%RH (no condensation)									
Alarm indication	Scale alarm indicated by LED on I/F Box									
Head cable length	2m									
Signal cable length	3m									
Data at "o" (ABS origin position)	Center of effective range	20mm left from edge of effective length		Center of effective range	20mm left from edge of effective length		Center of effective range	20mm left from edge of effective length		
I/O method	High-speed serial communication	DRIVE-CLiQ		High-speed serial communication	DRIVE-CLiQ		High-speed serial communication	DRIVE-CLiQ		

* Since the 20μm signal is divided by 4096, the actual value is 0.0048828125μm. When setting the minimum resolution on the controller, always enter the actual value.

System configuration (See instruction manual)

Configuration example 1

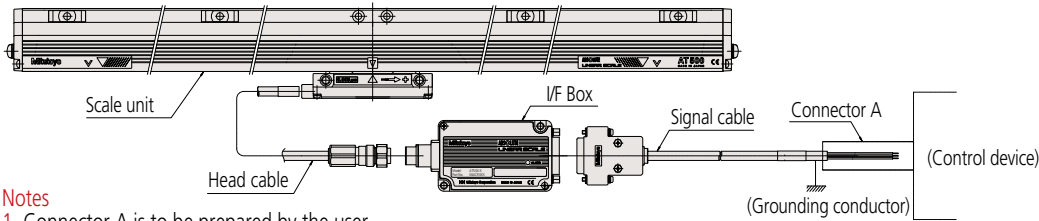

Notes

1. Connector A is to be prepared by the user.
2. Connector A and the grounding conductor are to be connected by the user.
3. In the above configuration, the maximum cable length is 10m for the head cable and 10m for the signal cable (total 20m). (Specifications other than the standard cable length are special order.)

Configuration example 2

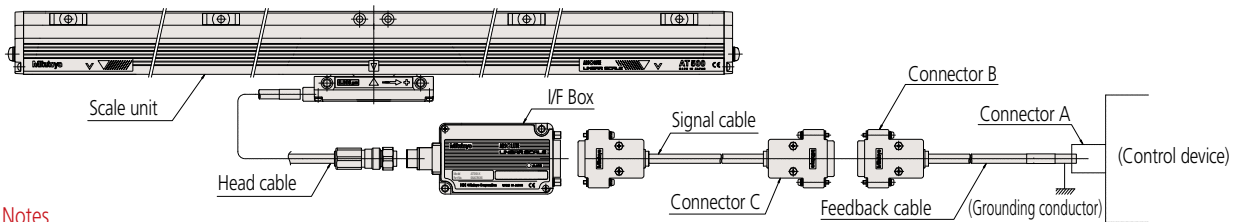

Notes

1. Connectors A/B/C and the feedback cable are to be prepared by the user.
2. Connectors A/B/C and the grounding conductor are to be connected by the user.
3. When fabricating a feedback cable, ensure that the total cable length is 29m or less. However, the maximum head cable length is 10m and the maximum signal cable length is 5m.

ABS AT545A

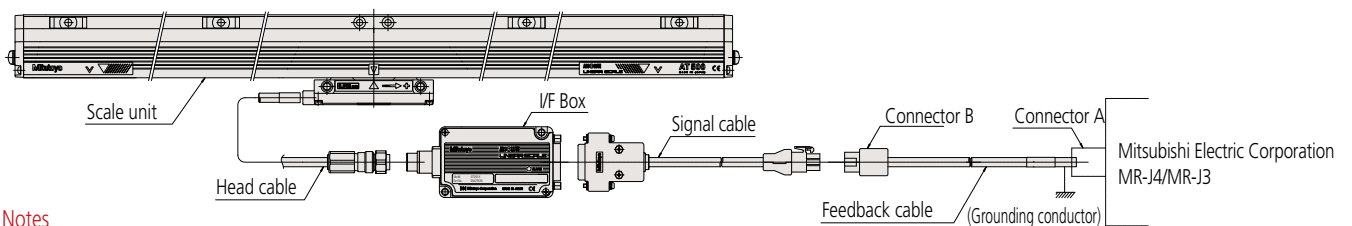

Notes

1. Connectors A/B and the feedback cable are to be prepared by the user.
2. Connectors A/B and the grounding conductor are to be connected by the user.
3. A Mitsubishi Electric Corporation encoder cable can be used as the feedback cable.
Model: MR-JCCBL□M-H □ is the cable length (2 or 5m)
* When using the encoder cable, ensure that the total cable length is 10m or less.
* The feedback cable configuration depends on the system. Please contact Mitsubishi Electric Corporation for details.

[ABS AT524/527]

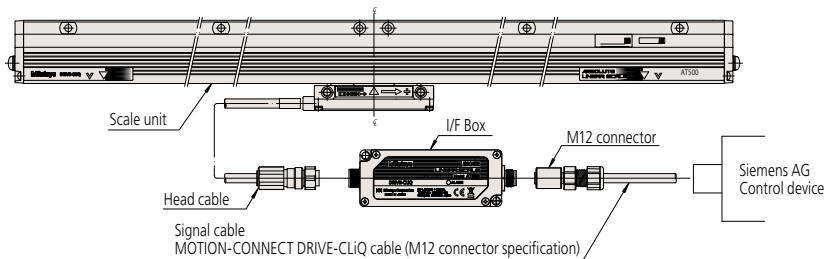

Notes

1. Siemens signal cable is to be used. MOTION-CONNECT DRIVE-CLiQ cable (M12 connector specification)
 2. Signal cable is to be prepared by the user.
- *A total length of head cable and signal cable should be 29 meters or shorter. However, maximum head cable length is 10m.

Output specification

• ABS AT555/AT545/AT505 (discrete-wire)

Wire color	Signal
Brown/Red	+5V
White/Black	GND
Orange	\overline{DT}
Yellow	DT
Green	\overline{REQ}
Blue	REQ
Purple	Phase A
Gray	Phase B
Shield	FG

Notes

- 1: Phase A and Phase B are used as test signals. Keep them disconnected during use.
- 2: Connect the shield wire to the grounding conductor.

• ABS AT505A (discrete-wire)

Wire color	Signal
Brown/Red	+5V
White/Black	GND
Orange	N.C
Yellow	N.C
Green	$\overline{REQ/DT}$
Blue	REQ/DT
Purple	Phase A
Gray	Phase B
Shield	FG

Notes

- 1: Phase A and Phase B are used as test signals. Keep them disconnected during use.
- 2: Connect the shield wire to the grounding conductor.

• ABS AT545A

Output connector (pin type): Tyco Electronics Japan
Mini-Universal Mate-N-Lock Connector 9P
172169-9 (Housing: Black)
Applicable connector: 172161-9 (Housing: Black)

Pin No.	Signal
1	MR (REQ/DT)
2	MRR ($\overline{REQ/DT}$)
4	(DT)
5	(\overline{DT})
7	PS (+5V)
8	OV (GND)
9	F.G
3.6	N.C

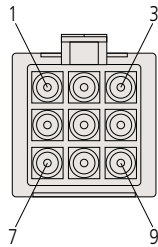

• ABS AT524/AT527

DRIVE CLiQ serial communication
Connector: M12 connector (male)

Pin No.	Signal
1	+24V
2	TEST
3	RXP
4	RXN
5	GND
6	TXN
7	TXP
8	\overline{TEST}
Shield sleeve	F.G

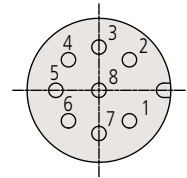

Note: Leave test terminals (TEST, \overline{TEST}) disconnected during use.

Cable dimensions

• ABS AT555/505

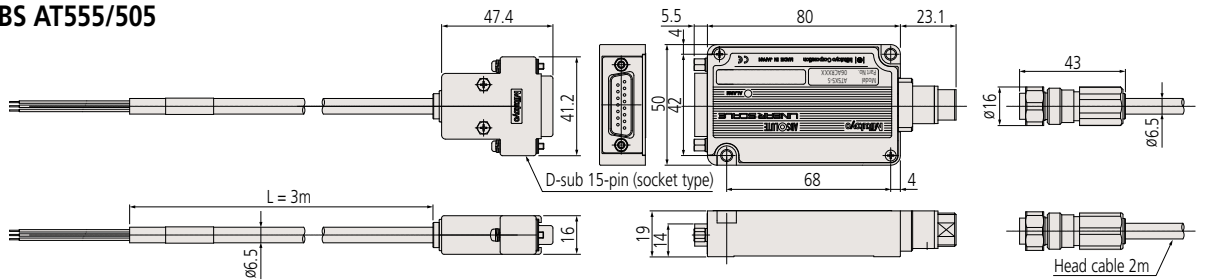

• ABS AT545A

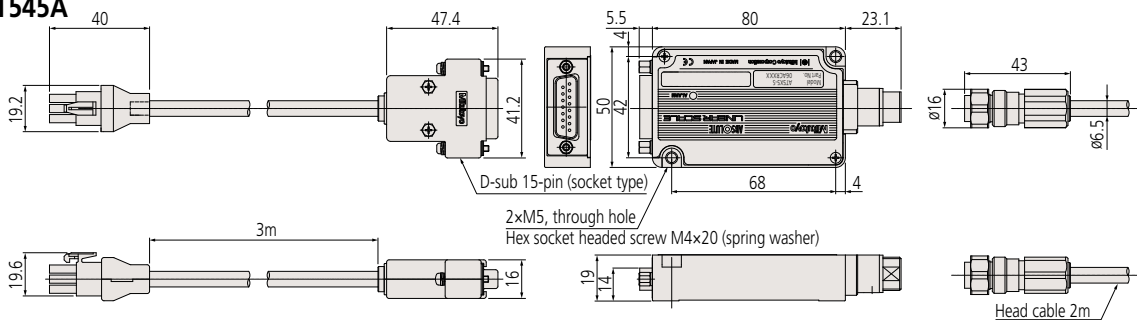

Mounting dimensions (SC Type)

Unit: mm

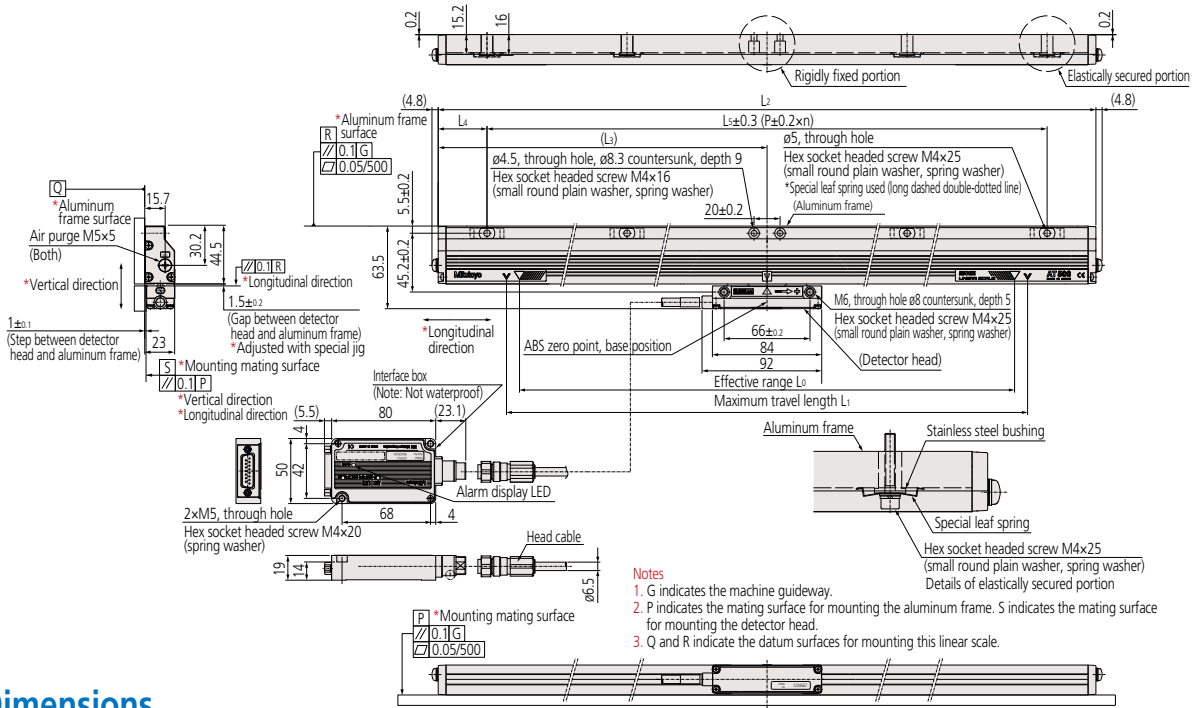

Dimensions

Effective range L ₀ (mm)	Maximum travel length L ₁ (mm)	Overall length L ₂ (mm)	Distance to center L ₃ (mm)	Mounting pitch			No. of mounting holes n
				L ₄ (mm)	L ₅ (mm)	P (mm)	
100	120	225	112.5	37.5	150	75	2
200	220	325	162.5	37.5	250	125	2
300	320	425	212.5	37.5	350	175	2
400	420	525	262.5	62.5	400	200	2
500	520	625	312.5	62.5	500	125	4
600	620	725	362.5	62.5	600	150	4
700	720	825	412.5	62.5	700	175	4
800	820	925	462.5	62.5	800	200	4
900	920	1025	512.5	62.5	900	150	6
1000	1020	1125	562.5	37.5	1050	175	6
1100	1120	1225	612.5	87.5	1050	175	6
1200	1220	1325	662.5	62.5	1200	200	6
1300	1320	1425	712.5	112.5	1200	150	8
1400	1420	1525	762.5	62.5	1400	175	8
1500	1520	1625	812.5	112.5	1400	175	8
1600	1620	1725	862.5	62.5	1600	200	8
1800	1820	1925	962.5	87.5	1750	175	10
2000	2020	2125	1062.5	62.5	2000	200	10
2200	2220	2325	1162.5	112.5	2100	175	12

Codes and Order Numbers

• ABS AT555-SC

Order No.	Code
539-761-50	AT555- 100-SC
539-763-50	AT555- 200-SC
539-765-50	AT555- 300-SC
539-767-50	AT555- 400-SC
539-769-50	AT555- 500-SC
539-771-50	AT555- 600-SC
539-773-50	AT555- 700-SC
539-775-50	AT555- 800-SC
539-776-50	AT555- 900-SC
539-777-50	AT555-1000-SC
539-778-50	AT555-1100-SC
539-779-50	AT555-1200-SC
539-780-50	AT555-1300-SC
539-781-50	AT555-1400-SC
539-782-50	AT555-1500-SC
539-783-50	AT555-1600-SC
539-785-50	AT555-1800-SC
539-786-50	AT555-2000-SC
539-787-50	AT555-2200-SC

• ABS AT545/AT545A-SC

Order No.	Code
539-731-□□	AT545(A)- 100-SC
539-733-□□	AT545(A)- 200-SC
539-735-□□	AT545(A)- 300-SC
539-737-□□	AT545(A)- 400-SC
539-739-□□	AT545(A)- 500-SC
539-741-□□	AT545(A)- 600-SC
539-743-□□	AT545(A)- 700-SC
539-745-□□	AT545(A)- 800-SC
539-746-□□	AT545(A)- 900-SC
539-747-□□	AT545(A)-1000-SC
539-748-□□	AT545(A)-1100-SC
539-749-□□	AT545(A)-1200-SC
539-750-□□	AT545(A)-1300-SC
539-751-□□	AT545(A)-1400-SC
539-752-□□	AT545(A)-1500-SC
539-753-□□	AT545(A)-1600-SC
539-755-□□	AT545(A)-1800-SC
539-756-□□	AT545(A)-2000-SC
539-757-□□	AT545(A)-2200-SC

• ABS AT505/AT505A-SC

Order No.	Code
539-161-□□	AT505(A)- 100-SC
539-163-□□	AT505(A)- 200-SC
539-165-□□	AT505(A)- 300-SC
539-167-□□	AT505(A)- 400-SC
539-169-□□	AT505(A)- 500-SC
539-171-□□	AT505(A)- 600-SC
539-173-□□	AT505(A)- 700-SC
539-175-□□	AT505(A)- 800-SC
539-176-□□	AT505(A)- 900-SC
539-177-□□	AT505(A)-1000-SC
539-178-□□	AT505(A)-1100-SC
539-179-□□	AT505(A)-1200-SC
539-180-□□	AT505(A)-1300-SC
539-181-□□	AT505(A)-1400-SC
539-182-□□	AT505(A)-1500-SC
539-183-□□	AT505(A)-1600-SC
539-185-□□	AT505(A)-1800-SC
539-186-□□	AT505(A)-2000-SC
539-187-□□	AT505(A)-2200-SC

* The □□ in the Order No. is as follows. AT545 : 50
AT545A: 51

* The □□ in the Order No. is as follows. AT505 : 50
AT505A: 51

Mounting dimensions AT524/527-SC

Unit: mm

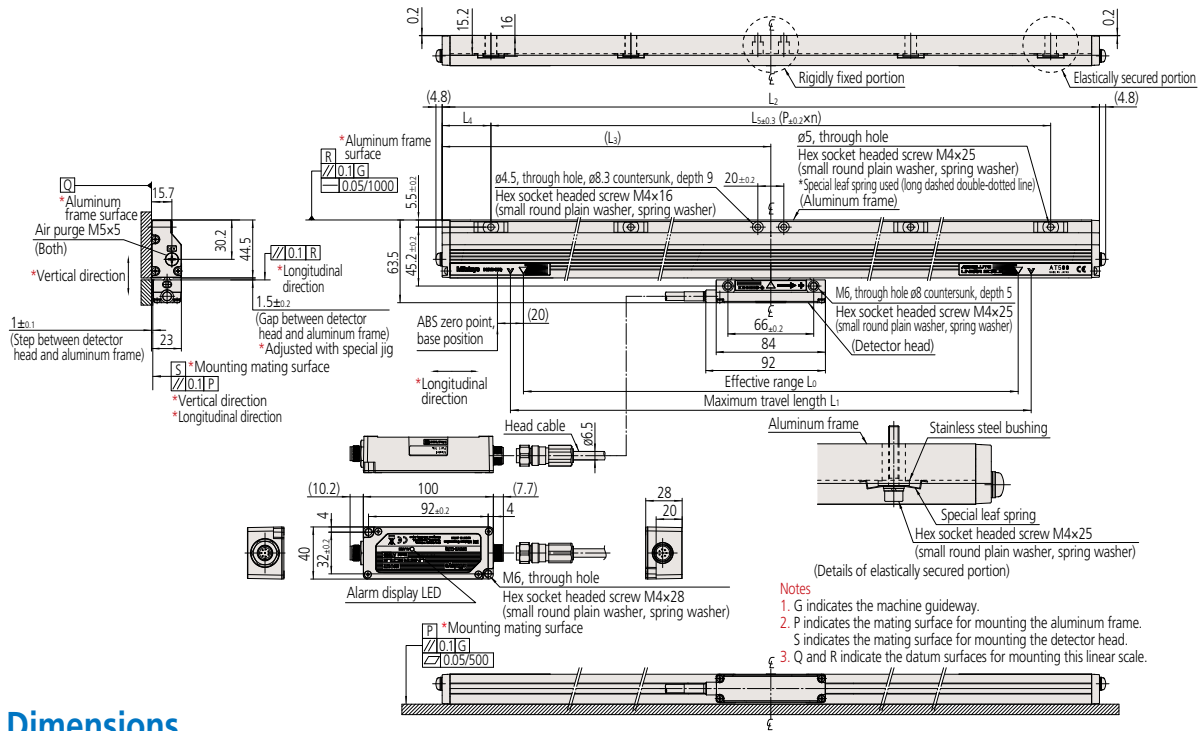

Dimensions

Effective range Lo (mm)	Maximum travel length L1 (mm)	Overall length L2 (mm)	Distance to center L3 (mm)	Mounting pitch			No. of mounting holes n
				L4 (mm)	L5 (mm)	P (mm)	
100	120	225	112.5	37.5	150	75	2
200	220	325	162.5	37.5	250	125	2
300	320	425	212.5	37.5	350	175	2
400	420	525	262.5	62.5	400	200	2
500	520	625	312.5	62.5	500	125	4
600	620	725	362.5	62.5	600	150	4
700	720	825	412.5	62.5	700	175	4
800	820	925	462.5	62.5	800	200	4
900	920	1025	512.5	62.5	900	150	6
1000	1020	1125	562.5	37.5	1050	175	6
1100	1120	1225	612.5	87.5	1050	175	6
1200	1220	1325	616.5	62.5	1200	200	6
1300	1320	1425	712.5	112.5	1200	150	8
1400	1420	1525	762.5	62.5	1400	175	8
1500	1520	1625	812.5	112.5	1400	175	8
1600	1620	1725	862.5	62.5	1600	200	8
1800	1820	1925	962.5	87.5	1750	175	10
2000	2020	2125	1062.5	62.5	2000	200	10
2200	2220	2325	1162.5	112.5	2100	175	12

Codes and Order Numbers

• ABS AT524-SC

Order No.	Code
539-901N-13	AT524- 100-SC
539-903N-13	AT524- 200-SC
539-905N-13	AT524- 300-SC
539-907N-13	AT524- 400-SC
539-909N-13	AT524- 500-SC
539-911N-13	AT524- 600-SC
539-913N-13	AT524- 700-SC
539-915N-13	AT524- 800-SC
539-916N-13	AT524- 900-SC
539-917N-13	AT524-1000-SC
539-918N-13	AT524-1100-SC
539-919N-13	AT524-1200-SC
539-920N-13	AT524-1300-SC
539-921N-13	AT524-1400-SC
539-922N-13	AT524-1500-SC
539-923N-13	AT524-1600-SC
539-924N-13	AT524-1800-SC
539-925N-13	AT524-2000-SC
539-926N-13	AT524-2200-SC

• ABS AT527-SC

Order No.	Code
539-901N-53	AT527- 100-SC
539-903N-53	AT527- 200-SC
539-905N-53	AT527- 300-SC
539-907N-53	AT527- 400-SC
539-909N-53	AT527- 500-SC
539-911N-53	AT527- 600-SC
539-913N-53	AT527- 700-SC
539-915N-53	AT527- 800-SC
539-916N-53	AT527- 900-SC
539-917N-53	AT527-1000-SC
539-918N-53	AT527-1100-SC
539-919N-53	AT527-1200-SC
539-920N-53	AT527-1300-SC
539-921N-53	AT527-1400-SC
539-922N-53	AT527-1500-SC
539-923N-53	AT527-1600-SC
539-924N-53	AT527-1800-SC
539-925N-53	AT527-2000-SC
539-926N-53	AT527-2200-SC

Mounting dimensions (HC Type)

Unit: mm

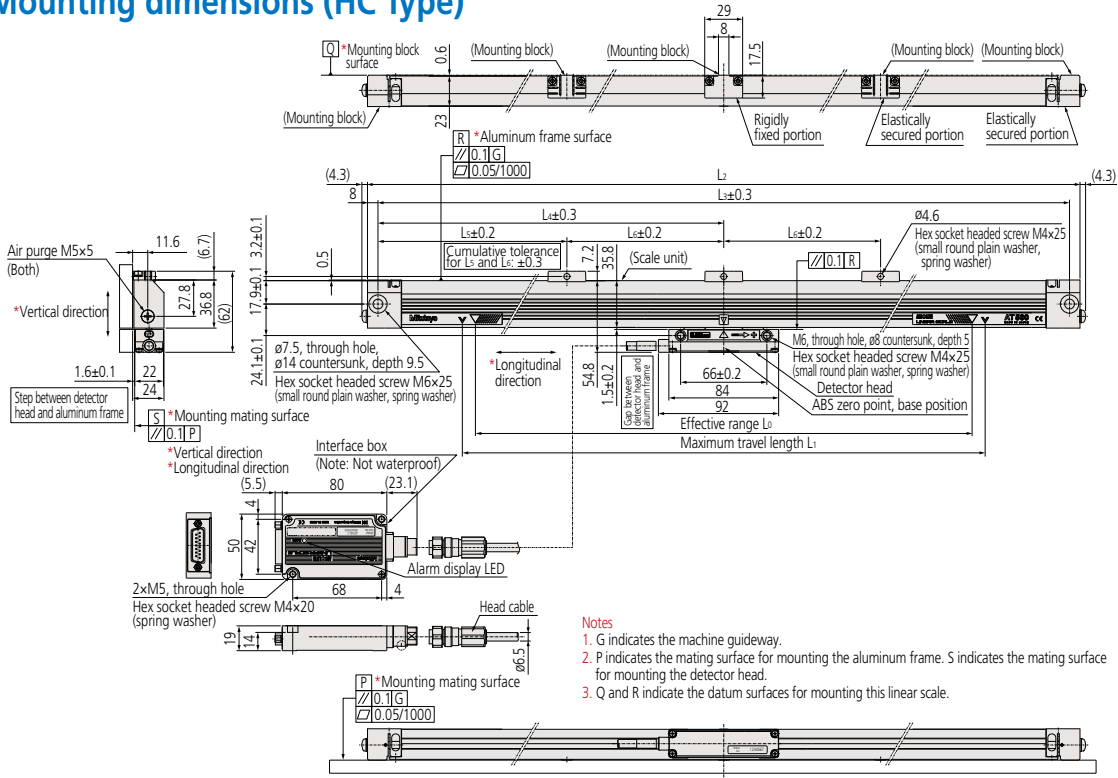

- Notes**
1. G indicates the machine guideway.
 2. P indicates the mating surface for mounting the aluminum frame. S indicates the mating surface for mounting the detector head.
 3. Q and R indicate the datum surfaces for mounting this linear scale.

Dimensions

Effective range L ₀ (mm)	Maximum travel length L ₁ (mm)	Overall length L ₂ (mm)	Mounting pitch			
			L ₃ (mm)	L ₄ (mm)	L ₅ (mm)	L ₆ (mm)
100	120	265	249	124.5	—	—
150	170	315	299	149.5	—	—
200	220	365	349	174.5	—	—
250	270	415	399	199.5	—	—
300	320	465	449	224.5	—	—
350	370	515	499	249.5	—	—
400	420	565	549	274.5	—	—
450	470	615	599	299.5	—	—
500	520	665	649	324.5	—	—
600	620	765	749	(374.5)	204.5	170
700	720	865	849	(424.5)	224.5	200
750	770	915	899	(449.5)	224.5	225
800	820	965	949	(474.5)	244.5	230
900	920	1065	1049	(524.5)	264.5	260
1000	1020	1165	1149	(574.5)	284.5	290

Codes and Order Numbers

• ABS AT555-HC

Order No.	Code
539-761-60	AT555- 100-HC
539-762-60	AT555- 150-HC
539-763-60	AT555- 200-HC
539-764-60	AT555- 250-HC
539-765-60	AT555- 300-HC
539-766-60	AT555- 350-HC
539-767-60	AT555- 400-HC
539-768-60	AT555- 450-HC
539-769-60	AT555- 500-HC
539-771-60	AT555- 600-HC
539-773-60	AT555- 700-HC
539-774-60	AT555- 750-HC
539-775-60	AT555- 800-HC
539-776-60	AT555- 900-HC
539-777-60	AT555-1000-HC

• ABS AT545/AT545A-HC

Order No.	Code
539-731-□□	AT545(A)- 100-HC
539-732-□□	AT545(A)- 150-HC
539-733-□□	AT545(A)- 200-HC
539-734-□□	AT545(A)- 250-HC
539-735-□□	AT545(A)- 300-HC
539-736-□□	AT545(A)- 350-HC
539-737-□□	AT545(A)- 400-HC
539-738-□□	AT545(A)- 450-HC
539-739-□□	AT545(A)- 500-HC
539-741-□□	AT545(A)- 600-HC
539-743-□□	AT545(A)- 700-HC
539-744-□□	AT545(A)- 750-HC
539-745-□□	AT545(A)- 800-HC
539-746-□□	AT545(A)- 900-HC
539-747-□□	AT545(A)-1000-HC

* The □□ in the Order No. is as follows. AT545 : 60
AT545A: 61

• ABS AT505/AT505A-HC

Order No.	Code
539-161-□□	AT505(A)- 100-HC
539-162-□□	AT505(A)- 150-HC
539-163-□□	AT505(A)- 200-HC
539-164-□□	AT505(A)- 250-HC
539-165-□□	AT505(A)- 300-HC
539-166-□□	AT505(A)- 350-HC
539-167-□□	AT505(A)- 400-HC
539-168-□□	AT505(A)- 450-HC
539-169-□□	AT505(A)- 500-HC
539-171-□□	AT505(A)- 600-HC
539-173-□□	AT505(A)- 700-HC
539-174-□□	AT505(A)- 750-HC
539-175-□□	AT505(A)- 800-HC
539-176-□□	AT505(A)- 900-HC
539-177-□□	AT505(A)-1000-HC

* The □□ in the Order No. is as follows. AT545 : 60
AT545A: 61

Mounting dimensions AT524/527-HC

Unit: mm

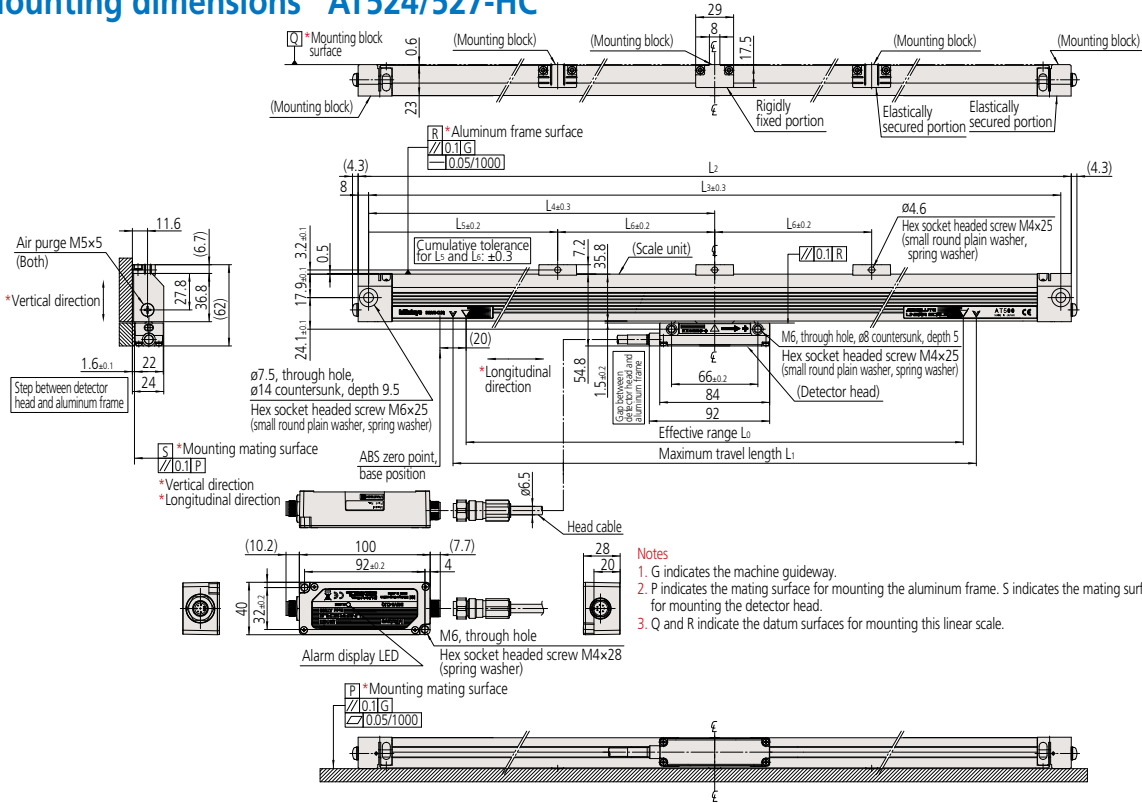

- Notes**
1. G indicates the machine guideway.
 2. P indicates the mating surface for mounting the aluminum frame. S indicates the mating surface for mounting the detector head.
 3. Q and R indicate the datum surfaces for mounting this linear scale.

Dimensions

Effective range L ₀ (mm)	Maximum travel length L ₁ (mm)	Overall length L ₂ (mm)	Mounting pitch			
			L ₃ (mm)	L ₄ (mm)	L ₅ (mm)	L ₆ (mm)
100	120	265	249	124.5	—	—
150	170	315	299	149.5	—	—
200	220	365	349	174.5	—	—
250	270	415	399	199.5	—	—
300	320	465	449	224.5	—	—
350	370	515	499	249.5	—	—
400	420	565	549	274.5	—	—
450	470	615	599	299.5	—	—
500	520	665	649	324.5	—	—
600	620	765	749	(374.5)	204.5	170
700	720	865	849	(424.5)	204.5	200
750	770	915	899	(449.5)	204.5	225
800	820	965	949	(474.5)	244.5	230
900	920	1065	1049	(524.5)	264.5	260
1000	1020	1165	1149	(574.5)	284.5	290

Codes and Order Numbers

• ABS AT524-HC

Order No.	Code
539-901N-23	AT524- 100-HC
539-902N-23	AT524- 150-HC
539-903N-23	AT524- 200-HC
539-904N-23	AT524- 250-HC
539-905N-23	AT524- 300-HC
539-906N-23	AT524- 350-HC
539-907N-23	AT524- 400-HC
539-908N-23	AT524- 450-HC
539-909N-23	AT524- 500-HC
539-911N-23	AT524- 600-HC
539-913N-23	AT524- 700-HC
539-914N-23	AT524- 750-HC
539-915N-23	AT524- 800-HC
539-916N-23	AT524- 900-HC
539-917N-23	AT524-1000-HC

• ABS AT527-HC

Order No.	Code
539-901N-63	AT527- 100-HC
539-902N-63	AT527- 150-HC
539-903N-63	AT527- 200-HC
539-904N-63	AT527- 250-HC
539-905N-63	AT527- 300-HC
539-906N-63	AT527- 350-HC
539-907N-63	AT527- 400-HC
539-908N-63	AT527- 450-HC
539-909N-63	AT527- 500-HC
539-911N-63	AT527- 600-HC
539-913N-63	AT527- 700-HC
539-914N-63	AT527- 750-HC
539-915N-63	AT527- 800-HC
539-916N-63	AT527- 900-HC
539-917N-63	AT527-1000-HC

Absolute Scale Unit
ABS AT500 Series

Mounting dimensions (HR Type)

Unit: mm

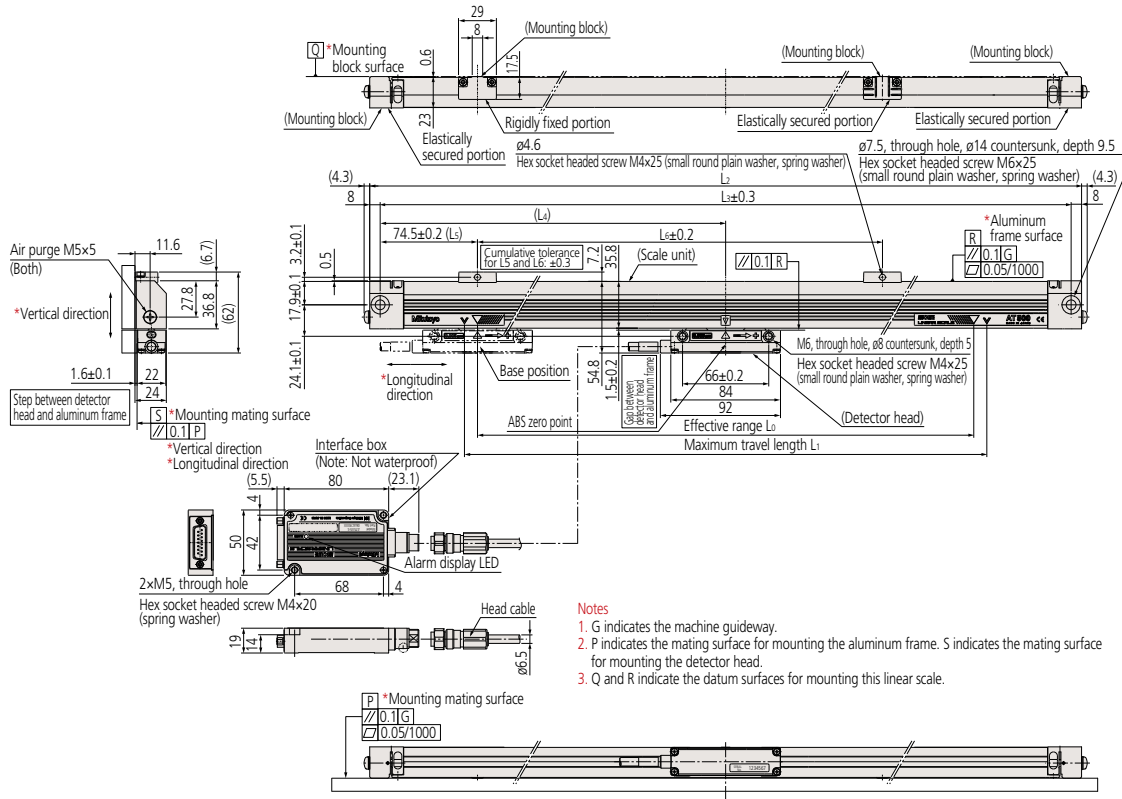

- Notes**
1. G indicates the machine guideway.
 2. P indicates the mating surface for mounting the aluminum frame. S indicates the mating surface for mounting the detector head.
 3. Q and R indicate the datum surfaces for mounting this linear scale.

Dimensions

Effective range L ₀ (mm)	Maximum travel length L ₁ (mm)	Overall length L ₂ (mm)	Mounting pitch		
			L ₃ (mm)	L ₄ (mm)	L ₆ (mm)
100	120	265	249	124.5	—
150	170	315	299	149.5	100
200	220	365	349	174.5	130
250	270	415	399	199.5	160
300	320	465	449	224.5	190
350	370	515	499	249.5	220

Codes and Order Numbers

• ABS AT555-HR

Order No.	Code
539-761-70	AT555-100-HR
539-762-70	AT555-150-HR
539-763-70	AT555-200-HR
539-764-70	AT555-250-HR
539-765-70	AT555-300-HR
539-766-70	AT555-350-HR

• ABS AT545/AT545A-HR

Order No.	Code
539-731-□□	AT545(A)-100-HR
539-732-□□	AT545(A)-150-HR
539-733-□□	AT545(A)-200-HR
539-734-□□	AT545(A)-250-HR
539-735-□□	AT545(A)-300-HR
539-736-□□	AT545(A)-350-HR

* The □□ in the Order No. is as follows. AT545 : 70
AT545A: 71

• ABS AT505/AT505A-HR

Order No.	Code
539-161-□□	AT505(A)-100-HR
539-162-□□	AT505(A)-150-HR
539-163-□□	AT505(A)-200-HR
539-164-□□	AT505(A)-250-HR
539-165-□□	AT505(A)-300-HR
539-166-□□	AT505(A)-350-HR

* The □□ in the Order No. is as follows. AT505 : 70
AT505A: 71

Mounting dimensions AT524/527-HR

Unit: mm

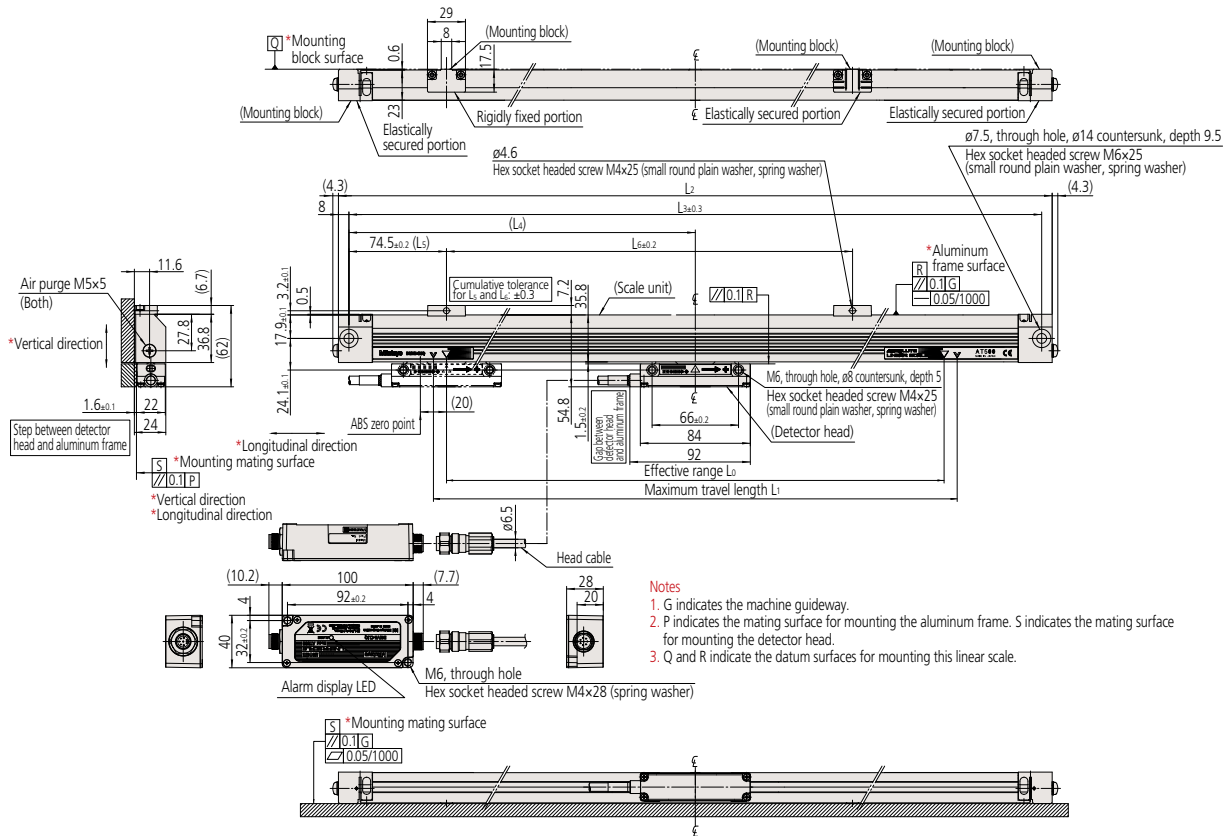

Dimensions

Effective range L ₀ (mm)	Maximum travel length L ₁ (mm)	Overall length L ₂ (mm)	Mounting pitch		
			L ₃ (mm)	L ₄ (mm)	L ₅ (mm)
100	120	265	249	124.5	—
150	170	315	299	149.5	100
200	220	365	349	174.5	130
250	270	415	399	199.5	160
300	320	465	449	224.5	190
350	370	515	499	249.5	220

Codes and Order Numbers

• ABS AT524-HR

Order No.	Code
539-901N-33	AT524- 100-HR
539-902N-33	AT524- 150-HR
539-903N-33	AT524- 200-HR
539-904N-33	AT524- 250-HR
539-905N-33	AT524- 300-HR
539-906N-33	AT524- 350-HR

• ABS AT527-HR

Order No.	Code
539-901N-73	AT527- 100-HR
539-902N-73	AT527- 150-HR
539-903N-73	AT527- 200-HR
539-904N-73	AT527- 250-HR
539-905N-73	AT527- 300-HR
539-906N-73	AT527- 350-HR

Mounting dimensions (HL Type)

Unit: mm

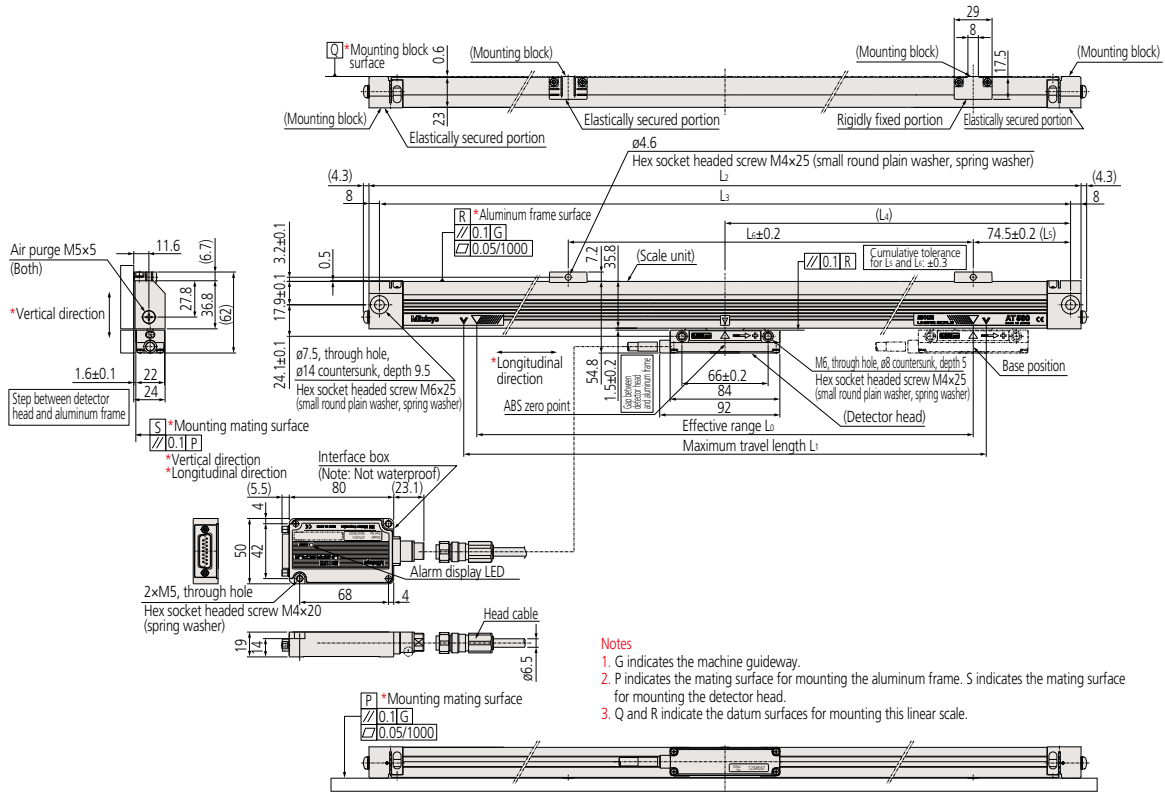

Dimensions

Effective range L ₀ (mm)	Maximum travel length L ₁ (mm)	Overall length L ₂ (mm)	Mounting pitch		
			L ₃ (mm)	L ₄ (mm)	L ₆ (mm)
100	120	265	249	124.5	—
150	170	315	299	149.5	100
200	220	365	349	174.5	130
250	270	415	399	199.5	160
300	320	465	449	224.5	190
350	370	515	499	249.5	220

Codes and Order Numbers

• ABS AT555-HL

Order No.	Code
539-761-80	AT555-100-HL
539-762-80	AT555-150-HL
539-763-80	AT555-200-HL
539-764-80	AT555-250-HL
539-765-80	AT555-300-HL
539-766-80	AT555-350-HL

• ABS AT545/AT545A-HL

Order No.	Code
539-731-□□	AT545(A)-100-HL
539-732-□□	AT545(A)-150-HL
539-733-□□	AT545(A)-200-HL
539-734-□□	AT545(A)-250-HL
539-735-□□	AT545(A)-300-HL
539-736-□□	AT545(A)-350-HL

* The □□ in the Order No. is as follows. AT545 : 80
AT545A: 81

• ABS AT505/AT505A-HL

Order No.	Code
539-161-□□	AT505(A)-100-HR
539-162-□□	AT505(A)-150-HR
539-163-□□	AT505(A)-200-HR
539-164-□□	AT505(A)-250-HR
539-165-□□	AT505(A)-300-HR
539-166-□□	AT505(A)-350-HR

* The □□ in the Order No. is as follows. AT505 : 80
AT505A: 81

Mounting dimensions AT524/527-HC

単位 : mm

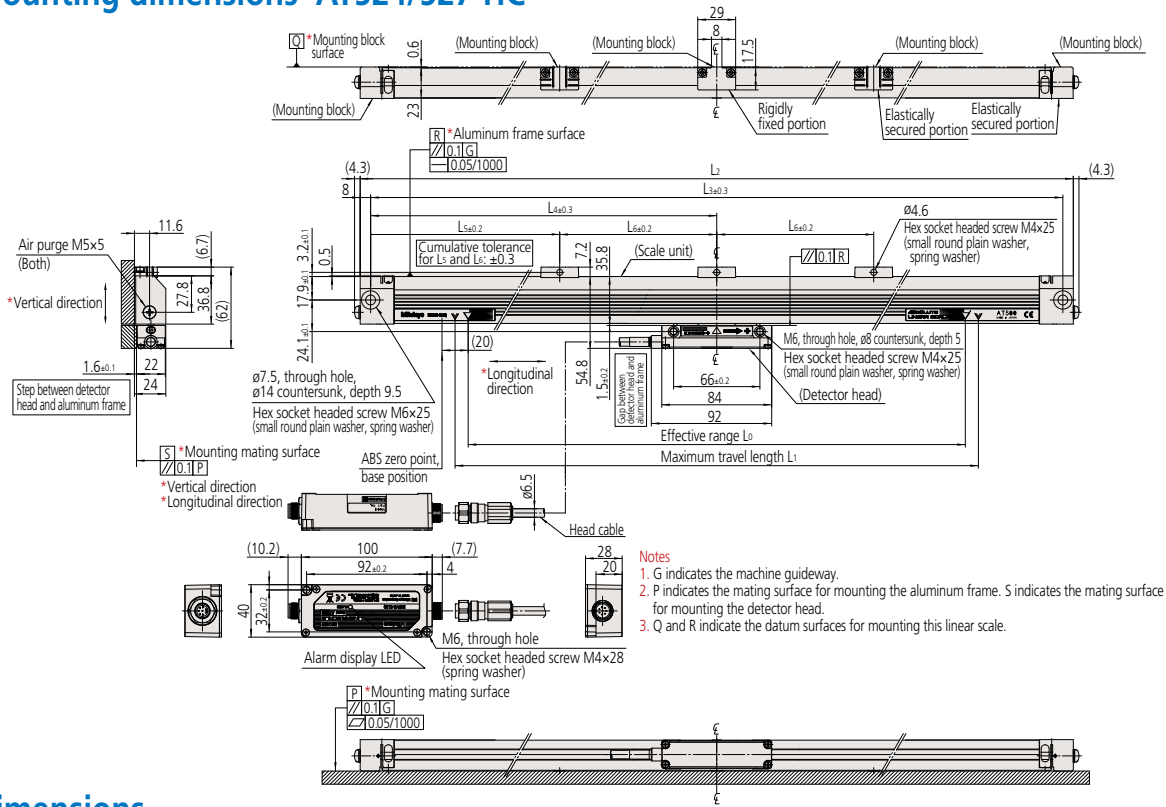

- Notes
1. G indicates the machine guideway.
 2. P indicates the mating surface for mounting the aluminum frame. S indicates the mating surface for mounting the detector head.
 3. Q and R indicate the datum surfaces for mounting this linear scale.

Dimensions

Effective range L ₀ (mm)	Maximum travel length L ₁ (mm)	Overall length L ₂ (mm)	Mounting pitch			
			L ₃ (mm)	L ₄ (mm)	L ₅ (mm)	L ₆ (mm)
100	120	265	249	124.5	—	—
150	170	315	299	149.5	—	—
200	220	365	349	174.5	—	—
250	270	415	399	199.5	—	—
300	320	465	449	224.5	—	—
350	370	515	499	249.5	—	—
400	420	565	549	274.5	—	—
450	470	615	599	299.5	—	—
500	520	665	649	324.5	—	—
600	620	765	749	(374.5)	204.5	170
700	720	865	849	(424.5)	204.5	200
750	770	915	899	(449.5)	204.5	225
800	820	965	949	(474.5)	244.5	230
900	920	1065	1049	(524.5)	264.5	260
1000	1020	1165	1149	(574.5)	284.5	290

Codes and Order Numbers

• ABS AT524-HC

Order No.	Code
539-901N-23	AT524- 100-HC
539-902N-23	AT524- 150-HC
539-903N-23	AT524- 200-HC
539-904N-23	AT524- 250-HC
539-905N-23	AT524- 300-HC
539-906N-23	AT524- 350-HC
539-907N-23	AT524- 400-HC
539-908N-23	AT524- 450-HC
539-909N-23	AT524- 500-HC
539-911N-23	AT524- 600-HC
539-913N-23	AT524- 700-HC
539-914N-23	AT524- 750-HC
539-915N-23	AT524- 800-HC
539-916N-23	AT524- 900-HC
539-917N-23	AT524-1000-HC

• ABS AT527-HC

Order No.	Code
539-901N-63	AT527- 100-HC
539-902N-63	AT527- 150-HC
539-903N-63	AT527- 200-HC
539-904N-63	AT527- 250-HC
539-905N-63	AT527- 300-HC
539-906N-63	AT527- 350-HC
539-907N-63	AT527- 400-HC
539-908N-63	AT527- 450-HC
539-909N-63	AT527- 500-HC
539-911N-63	AT527- 600-HC
539-913N-63	AT527- 700-HC
539-914N-63	AT527- 750-HC
539-915N-63	AT527- 800-HC
539-916N-63	AT527- 900-HC
539-917N-63	AT527-1000-HC

Absolute Scale Unit
ABS AT500 Series

Assembly Type ABS AT Series

Absolute Scale Unit (Slim Spar Type)

ABS AT500 Series

(Resolution 0.05 μ m)



ABSOLUTE™

Features

- High-performance Absolute Linear Scale with a resolution of 0.05 μ m and maximum response speed of 150 m/min.
- The ABS AT500-S Series realizes vibration resistance of 196m/s² (20G) and shock-resistance of 343m/s² (35G), suitable for use with heavy cutting equipment and for high-speed machining.
- The ABS AT500-H Series has high repeatability, excellent temperature characteristics, and enables highly accurate and stable positioning.
- Slim shape is suitable for space-saving designs.
- Compatible with servo amplifiers from a range of companies (high-speed serial interfaces).

How to read the code

ABS AT5 3 - -

Interface specification	Effective range
Applicable systems	Scale code
FANUC Ltd. control devices FS-i Series POWER Mate i	ABS AT553
Mitsubishi Electric Corporation control devices MITSUBISHI CNC Series MDS-D/MDS-DH Series	ABS AT543
Mitsubishi Electric Corporation MR-J4/MR-J3 Series	ABS AT543A
Panasonic Corporation, Motor business unit MINAS-A5, A5L, A5N, A5NL Series MINAS-A4, A4P, A4N, A4NL Series	ABS AT573A
Amplifier compatible with the Mitutoyo ENSIS interface Nikki Denso Co., Ltd. VCII/VC/VPS Series*1 Servoland Corporation SVF Series*1 PMAC JAPAN Co., Ltd. UMAC-Turbo PMAC2 Other machine types	ABS AT503A ABS AT503

Base position (the 'zero elongation' point)*
C: Midpoint of effective range
L: End of effective range (+ side end)
R: End of effective range (- side end)
 Note: L and R are only for the high-accuracy type
 * This refers to the base point of fixed point on the scale around which clamping arrangements ensure that any expansion or contraction due to temperature change occurs.

Scale unit specifications
S: High-rigidity type
H: High-accuracy type

*1 For connection to ABS AT503A

Note: ABS AT53

Communication method
Blank: Full-duplex communication
A: Half-duplex communication

Note: For details regarding the applicable system, please consult with the individual manufacturer.

Scale configuration

ABS AT500-S Series

ABS AT53-SC
 ABS AT53A-SC

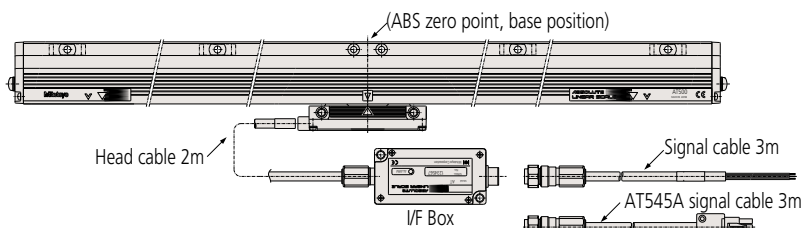

ABS AT500-H Series

ABS AT53-HC
 ABS AT53A-HC

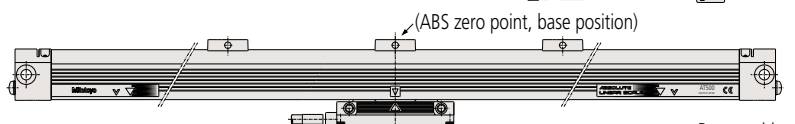

ABS AT53-HL
 ABS AT53A-HL

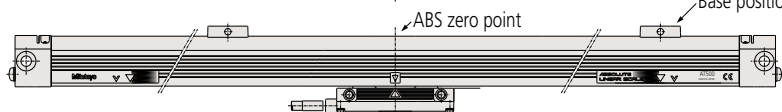

ABS AT53-HR
 ABS AT53A-HR

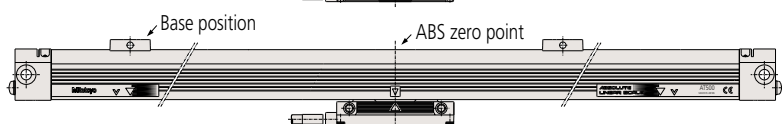

Absolute Scale Unit
ABS AT500 Series

Specifications

Item	Code	High-rigidity type	High-accuracy type	
		ABS AT5□3-SC	ABS AT5□3-HC	ABS AT5□3-HL/HR
Detection method		Electrostatic capacitance type / photoelectric type composite ABS linear encoder		
How to mount the scale unit		Multi-point elastic fixing	3 or 5-point elastic fixing	3 or 4-point elastic fixing
Base position		Midpoint of effective range		End of effective range HL: (+ side of absolute value) HR: (- side of absolute value)
Effective range		100 to 2200mm	100 to 1000mm	100 to 350mm
Resolution		0.05μm		
Maximum response speed		150m/min (2.5m/s)		
Accuracy (20°C)		(3+3L ₀ /1000) μm L ₀ : Effective range (mm)	(2+2L ₀ /1000) μm L ₀ : Effective range (mm)	
Thermal expansion coefficient		≈ 8.5 × 10 ⁻⁶ / K		
Vibration resistance		196 m/s ² (20G) (55 to 2000Hz)	147 m/s ² (15G) (55 to 2000Hz)	
Shock resistance		343m/s ² (35G) (half-sine 11ms)	196m/s ² (20G) (half-sine 11ms)	
Power supply voltage		5VDC±5%		
Maximum current consumption		270mA (Max)		
Maximum sliding force		4N		
Operating temperature/humidity		0 to 45°C, 20 to 80%RH (no condensation)		
Storage temperature/humidity		-20 to 70°C, 20 to 80%RH (no condensation)		
Alarm indication		Scale alarm indicated by LED on I/F Box		
Head cable length		2m		
Signal cable length		3m		

System configuration (See instruction manual)

Configuration example 1

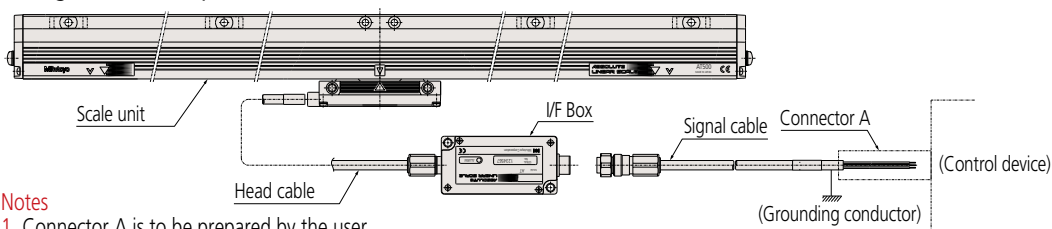

Notes

1. Connector A is to be prepared by the user.
2. Connector A and the grounding conductor are to be connected by the user.
3. In the above configuration, the maximum cable length is 10m for the head cable and 10m for the signal cable (total 20m). (Specifications other than the standard cable length are special order.)

Configuration example 2

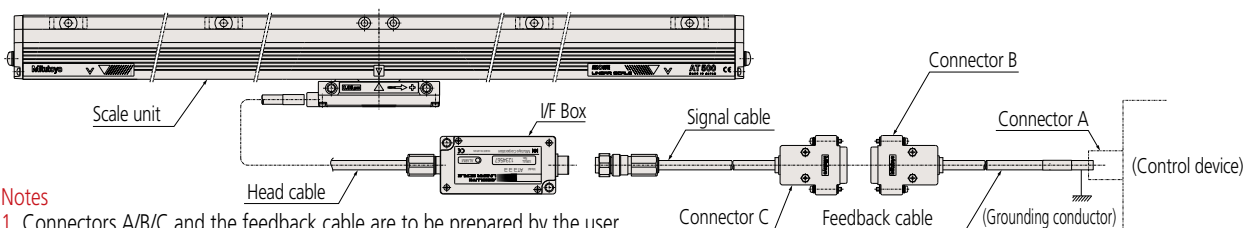

Notes

1. Connectors A/B/C and the feedback cable are to be prepared by the user.
2. Connectors A/B/C and the grounding conductor are to be connected by the user.
3. When fabricating a feedback cable, ensure that the total cable length is 29m or less. However, the maximum head cable length is 10m and the maximum signal cable length is 5m.

[ABS AT543A]

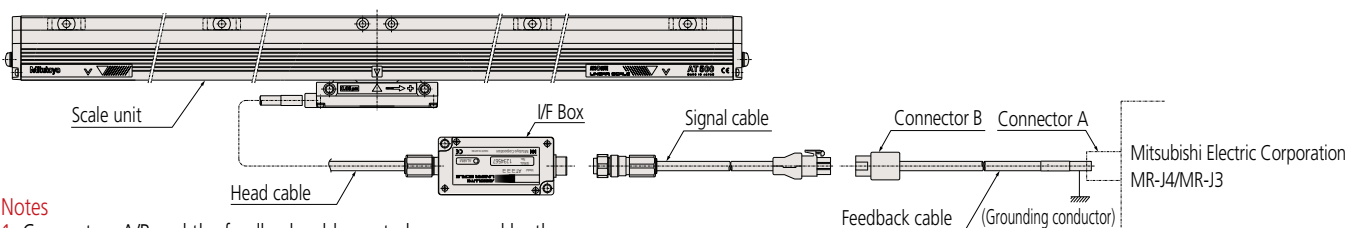

Notes

1. Connectors A/B and the feedback cable are to be prepared by the user.
2. Connectors A/B and the grounding conductor are to be connected by the user.
3. A Mitsubishi Electric Corporation encoder cable can be used as the feedback cable.
Model: MR-JCCBL□M-H □ is the cable length (2 or 5m)
* When using the encoder cable, ensure that the total cable length is 10m or less.
* The feedback cable configuration depends on the system. Please contact Mitsubishi Electric Corporation for details.

Output specification

• ABS AT553/AT543/AT503 (discrete-wire)

Wire color	Signal
Brown/Red	+5V
White/Black	GND
Orange	DT
Yellow	DT
Green	REQ
Blue	REQ
Purple	Phase A
Gray	Phase B
Shield	FG

Notes

- 1: Phase A and Phase B are used as test signals. Keep them disconnected during use.
- 2: Connect the shield wire to the grounding conductor.

• ABS AT545A

Output connector (pin type): Tyco Electronics Japan
Mini-Universal Mate-N-Lock Connector 9P
172169-9 (Housing: Black)
Applicable connector: 172161-9 (Housing: Black)

Pin No.	Signal
1	MR (REQ/DT)
2	MRR (REQ/DT)
4	(DT)
5	(DT)
7	PS (+5V)
8	LG (GND)
9	F.G
3.6	N.C

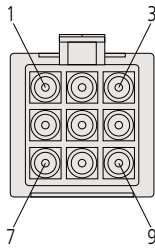

• ABS AT573A/AT503A (discrete-wire)

Wire color	Signal
Brown/Red	+5V
White/Black	GND
Orange	N.C
Yellow	N.C
Green	REQ/DT
Blue	REQ/DT
Purple	Phase A
Gray	Phase B
Shield	FG

Notes

- 1: Phase A and Phase B are used as test signals. Keep them disconnected during use.
- 2: Connect the shield wire to the grounding conductor.

Cable dimensions

• ABS AT553/AT543/AT573A/AT503 (A)

Unit: mm

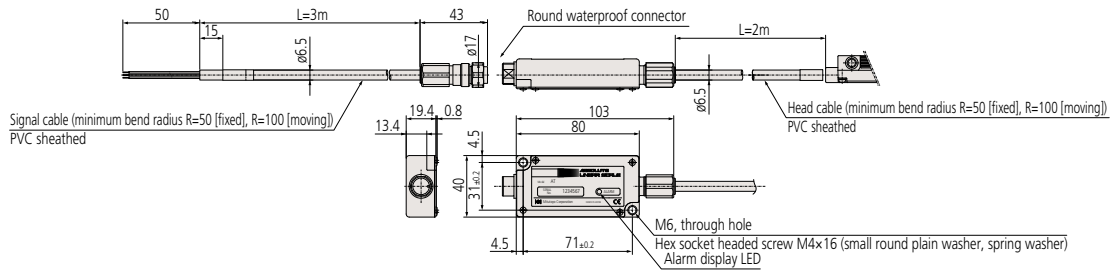

• ABS AT543A

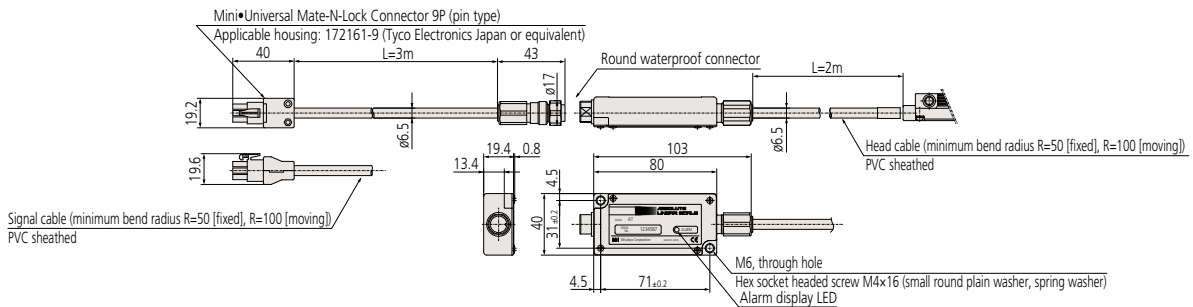

Mounting dimensions (SC Type)

Unit: mm

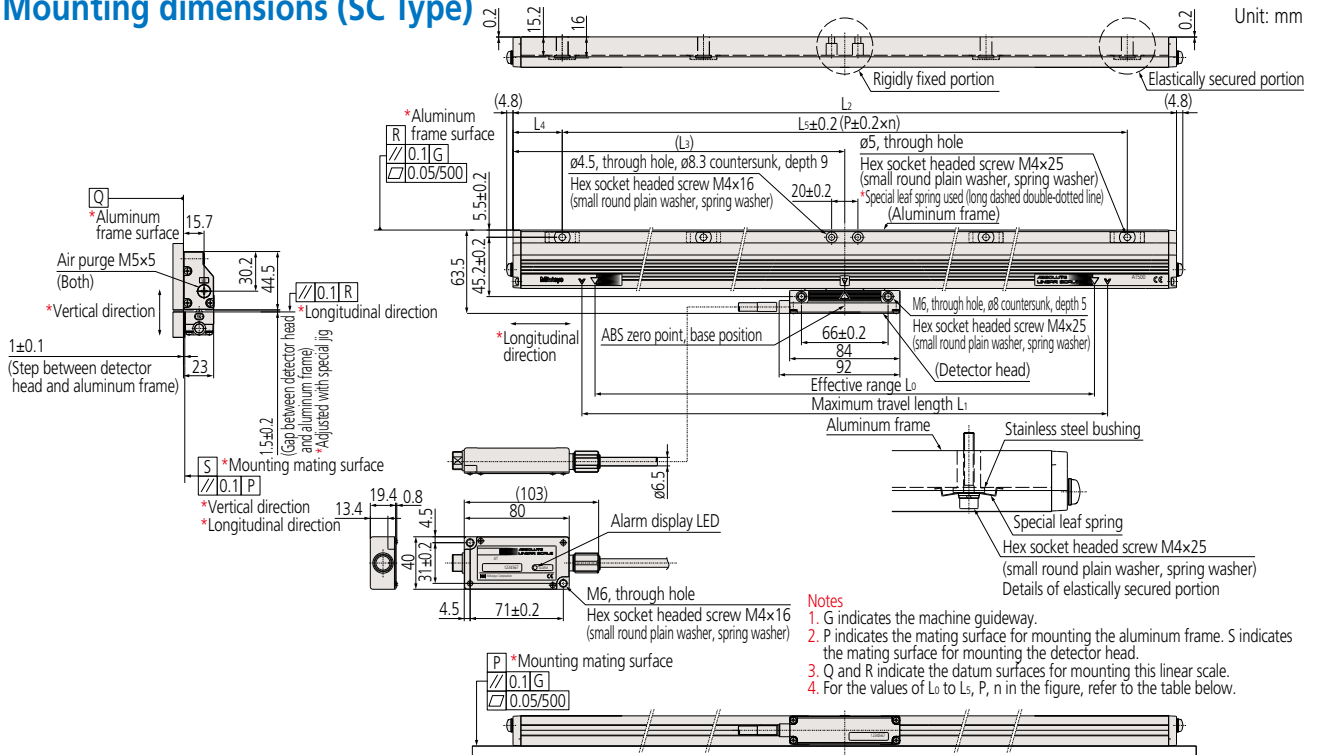

Dimensions

Effective range L_0 (mm)	Maximum travel length L_1 (mm)	Overall length L_2 (mm)	Distance to center L_3 (mm)	Mounting pitch			No. of mounting holes n
				L_4 (mm)	L_5 (mm)	P (mm)	
100	120	225	112.5	37.5	150	75	2
200	220	325	162.5	37.5	250	125	2
300	320	425	212.5	37.5	350	175	2
400	420	525	262.5	62.5	400	200	2
500	520	625	312.5	62.5	500	125	4
600	620	725	362.5	62.5	600	150	4
700	720	825	412.5	62.5	700	175	4
800	820	925	462.5	62.5	800	200	4
900	920	1025	512.5	62.5	900	150	6
1000	1020	1125	562.5	37.5	1050	175	6
1100	1120	1225	612.5	87.5	1050	175	6
1200	1220	1325	662.5	62.5	1200	200	6
1300	1320	1425	712.5	112.5	1200	150	8
1400	1420	1525	762.5	62.5	1400	175	8
1500	1520	1625	812.5	112.5	1400	175	8
1600	1620	1725	862.5	62.5	1600	200	8
1800	1820	1925	962.5	87.5	1750	175	10
2000	2020	2125	1062.5	62.5	2000	200	10
2200	2220	2325	1162.5	112.5	2100	175	12

Codes and Order Numbers

• ABS AT553-SC

Order No.	Code
539-761-10	AT553- 100-SC
539-763-10	AT553- 200-SC
539-765-10	AT553- 300-SC
539-767-10	AT553- 400-SC
539-769-10	AT553- 500-SC
539-771-10	AT553- 600-SC
539-773-10	AT553- 700-SC
539-775-10	AT553- 800-SC
539-776-10	AT553- 900-SC
539-777-10	AT553-1000-SC
539-778-10	AT553-1100-SC
539-779-10	AT553-1200-SC
539-780-10	AT553-1300-SC
539-781-10	AT553-1400-SC
539-782-10	AT553-1500-SC
539-783-10	AT553-1600-SC
539-785-10	AT553-1800-SC
539-786-10	AT553-2000-SC
539-787-10	AT553-2200-SC

• ABS AT543/AT543A-SC

Order No.	Code
539-731-□□	AT543(A)- 100-SC
539-733-□□	AT543(A)- 200-SC
539-735-□□	AT543(A)- 300-SC
539-737-□□	AT543(A)- 400-SC
539-739-□□	AT543(A)- 500-SC
539-741-□□	AT543(A)- 600-SC
539-743-□□	AT543(A)- 700-SC
539-745-□□	AT543(A)- 800-SC
539-746-□□	AT543(A)- 900-SC
539-747-□□	AT543(A)-1000-SC
539-748-□□	AT543(A)-1100-SC
539-749-□□	AT543(A)-1200-SC
539-750-□□	AT543(A)-1300-SC
539-751-□□	AT543(A)-1400-SC
539-752-□□	AT543(A)-1500-SC
539-753-□□	AT543(A)-1600-SC
539-755-□□	AT543(A)-1800-SC
539-756-□□	AT543(A)-2000-SC
539-757-□□	AT543(A)-2200-SC

* The □□ in the Order No. is as follows. AT543 : 10
AT543A: 11

• ABS AT573A-SC

Order No.	Code
539-871-11	AT573A- 100-SC
539-873-11	AT573A- 200-SC
539-875-11	AT573A- 300-SC
539-877-11	AT573A- 400-SC
539-879-11	AT573A- 500-SC
539-881-11	AT573A- 600-SC
539-883-11	AT573A- 700-SC
539-885-11	AT573A- 800-SC
539-886-11	AT573A- 900-SC
539-887-11	AT573A-1000-SC
539-888-11	AT573A-1100-SC
539-889-11	AT573A-1200-SC
539-890-11	AT573A-1300-SC
539-891-11	AT573A-1400-SC
539-892-11	AT573A-1500-SC
539-893-11	AT573A-1600-SC
539-895-11	AT573A-1800-SC
539-896-11	AT573A-2000-SC
539-897-11	AT573A-2200-SC

• ABS AT503/AT503A-SC

Order No.	Code
539-161-□□	AT503(A)- 100-SC
539-163-□□	AT503(A)- 200-SC
539-165-□□	AT503(A)- 300-SC
539-167-□□	AT503(A)- 400-SC
539-169-□□	AT503(A)- 500-SC
539-171-□□	AT503(A)- 600-SC
539-173-□□	AT503(A)- 700-SC
539-175-□□	AT503(A)- 800-SC
539-176-□□	AT503(A)- 900-SC
539-177-□□	AT503(A)-1000-SC
539-178-□□	AT503(A)-1100-SC
539-179-□□	AT503(A)-1200-SC
539-180-□□	AT503(A)-1300-SC
539-181-□□	AT503(A)-1400-SC
539-182-□□	AT503(A)-1500-SC
539-183-□□	AT503(A)-1600-SC
539-185-□□	AT503(A)-1800-SC
539-186-□□	AT503(A)-2000-SC
539-187-□□	AT503(A)-2200-SC

* The □□ in the Order No. is as follows. AT503 : 10
AT503A: 11

Mounting dimensions (HC Type)

Unit: mm

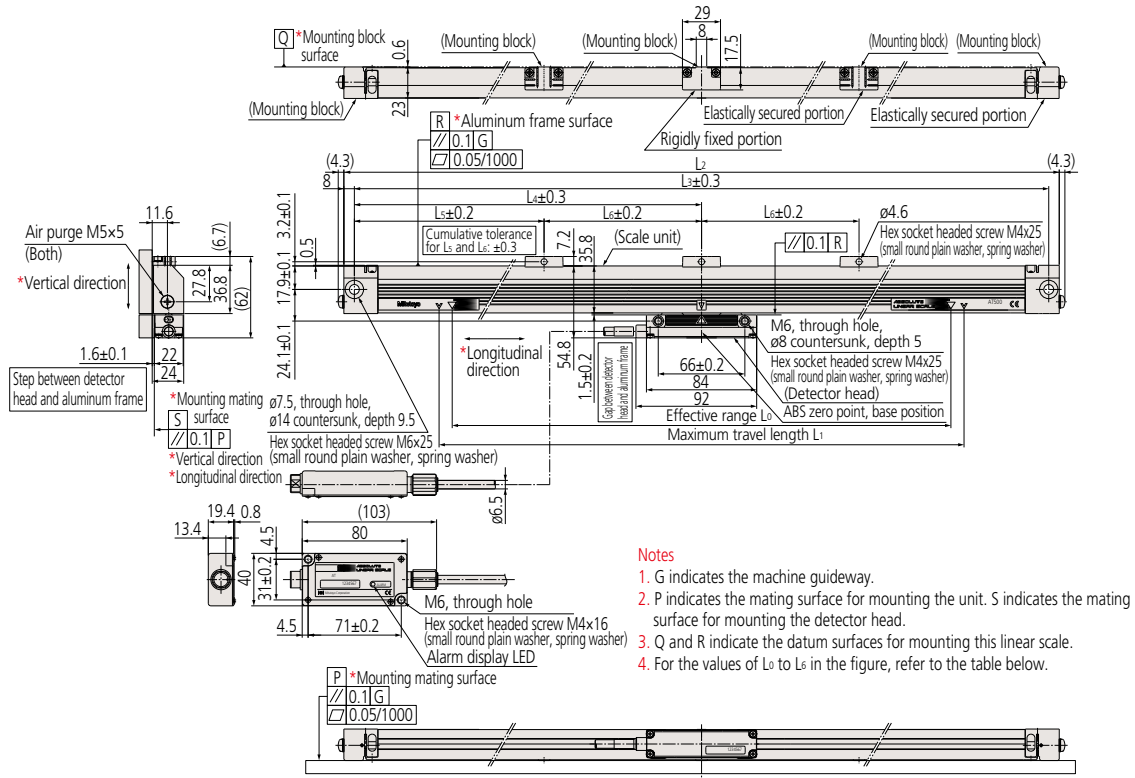

Dimension

Effective range L ₀ (mm)	Maximum travel length L ₁ (mm)	Overall length L _z (mm)	Mounting pitch			
			L ₃ (mm)	L ₄ (mm)	L ₅ (mm)	L ₆ (mm)
100	120	265	249	124.5	—	—
150	170	315	299	149.5	—	—
200	220	365	349	174.5	—	—
250	270	415	399	199.5	—	—
300	320	465	449	224.5	—	—
350	370	515	499	249.5	—	—
400	420	565	549	274.5	—	—
450	470	615	599	299.5	—	—
500	520	665	649	324.5	—	—
600	620	765	749	(374.5)	204.5	170
700	720	865	849	(424.5)	224.5	200
750	770	915	899	(449.5)	224.5	225
800	820	965	949	(474.5)	244.5	230
900	920	1065	1049	(524.5)	264.5	260
1000	1020	1165	1149	(574.5)	284.5	290

Codes and Order Numbers

• ABS AT553-HC

Order No.	Code
539-761-20	AT553- 100-HC
539-762-20	AT553- 150-HC
539-763-20	AT553- 200-HC
539-764-20	AT553- 250-HC
539-765-20	AT553- 300-HC
539-766-20	AT553- 350-HC
539-767-20	AT553- 400-HC
539-768-20	AT553- 450-HC
539-769-20	AT553- 500-HC
539-771-20	AT553- 600-HC
539-773-20	AT553- 700-HC
539-774-20	AT553- 750-HC
539-775-20	AT553- 800-HC
539-776-20	AT553- 900-HC
539-777-20	AT553-1000-HC

• ABS AT543/AT543A-HC

Order No.	Code
539-731-□□	AT543(A)- 100-HC
539-732-□□	AT543(A)- 150-HC
539-733-□□	AT543(A)- 200-HC
539-734-□□	AT543(A)- 250-HC
539-735-□□	AT543(A)- 300-HC
539-736-□□	AT543(A)- 350-HC
539-737-□□	AT543(A)- 400-HC
539-738-□□	AT543(A)- 450-HC
539-739-□□	AT543(A)- 500-HC
539-741-□□	AT543(A)- 600-HC
539-743-□□	AT543(A)- 700-HC
539-744-□□	AT543(A)- 750-HC
539-745-□□	AT543(A)- 800-HC
539-746-□□	AT543(A)- 900-HC
539-747-□□	AT543(A)-1000-HC

• ABS AT573A-HC

Order No.	Code
539-871-21	AT573A- 100-HC
539-872-21	AT573A- 150-HC
539-873-21	AT573A- 200-HC
539-874-21	AT573A- 250-HC
539-875-21	AT573A- 300-HC
539-876-21	AT573A- 350-HC
539-877-21	AT573A- 400-HC
539-878-21	AT573A- 450-HC
539-879-21	AT573A- 500-HC
539-881-21	AT573A- 600-HC
539-883-21	AT573A- 700-HC
539-884-21	AT573A- 750-HC
539-885-21	AT573A- 800-HC
539-886-21	AT573A- 900-HC
539-887-21	AT573A-1000-HC

• ABS AT503/AT503A-HC

Order No.	Code
539-161-□□	AT503(A)- 100-HC
539-162-□□	AT503(A)- 150-HC
539-163-□□	AT503(A)- 200-HC
539-164-□□	AT503(A)- 250-HC
539-165-□□	AT503(A)- 300-HC
539-166-□□	AT503(A)- 350-HC
539-167-□□	AT503(A)- 400-HC
539-168-□□	AT503(A)- 450-HC
539-169-□□	AT503(A)- 500-HC
539-171-□□	AT503(A)- 600-HC
539-173-□□	AT503(A)- 700-HC
539-174-□□	AT503(A)- 750-HC
539-175-□□	AT503(A)- 800-HC
539-176-□□	AT503(A)- 900-HC
539-177-□□	AT503(A)-1000-HC

* The □□ in the Order No. is as follows. AT543 : 20
AT543A: 21

* The □□ in the Order No. is as follows. AT503 : 10
AT503A: 11

Mounting dimensions (HR Type)

Unit: mm

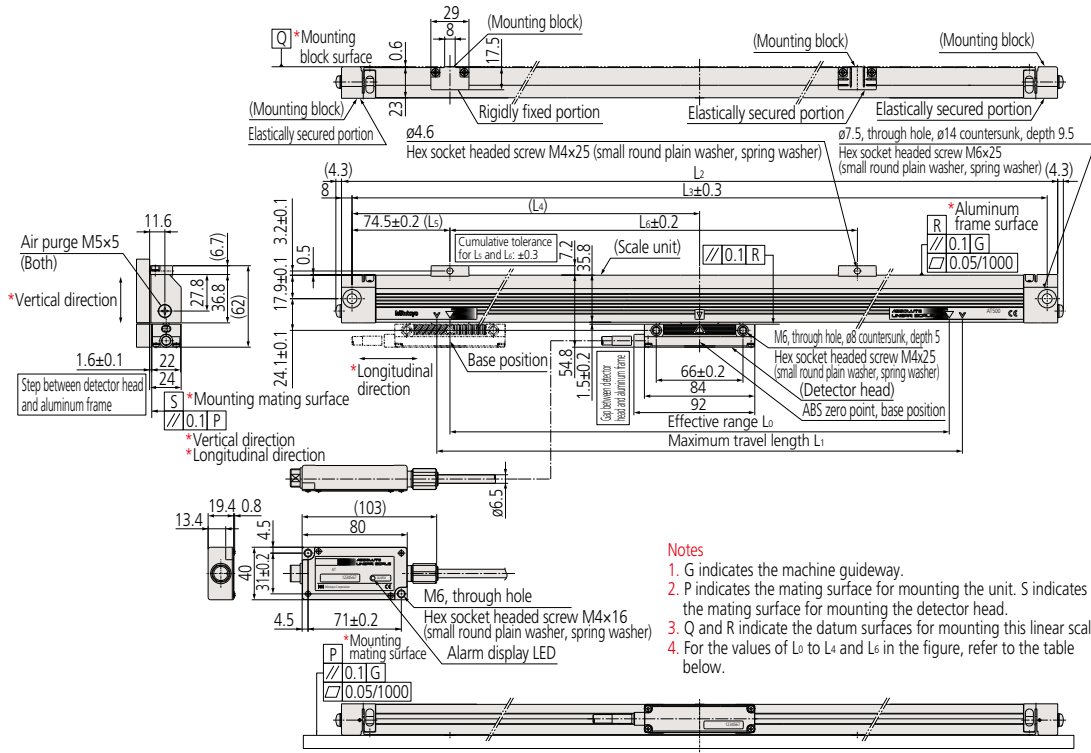

Dimensions

Effective range L_0 (mm)	Maximum travel length L_1 (mm)	Overall length L_2 (mm)	Mounting pitch		
			L_3 (mm)	L_4 (mm)	L_6 (mm)
100	120	265	249	124.5	—
150	170	315	299	149.5	100
200	220	365	349	174.5	130
250	270	415	399	199.5	160
300	320	465	449	224.5	190
350	370	515	499	249.5	220

Codes and Order Numbers

• ABS AT553-HR

Order No.	Code
539-761-30	AT553-100-HR
539-762-30	AT553-150-HR
539-763-30	AT553-200-HR
539-764-30	AT553-250-HR
539-765-30	AT553-300-HR
539-766-30	AT553-350-HR

• ABS AT543/AT543A-HR

Order No.	Code
539-731-□□	AT543(A)-100-HR
539-732-□□	AT543(A)-150-HR
539-733-□□	AT543(A)-200-HR
539-734-□□	AT543(A)-250-HR
539-735-□□	AT543(A)-300-HR
539-736-□□	AT543(A)-350-HR

* The □□ in the Order No. is as follows. AT543 : 30
AT543A: 31

• ABS AT573A-HR

Order No.	Code
539-871-31	AT573A-100-HR
539-872-31	AT573A-150-HR
539-873-31	AT573A-200-HR
539-874-31	AT573A-250-HR
539-875-31	AT573A-300-HR
539-876-31	AT573A-350-HR

• ABS AT503/AT503A-HR

Order No.	Code
539-161-□□	AT503(A)-100-HR
539-162-□□	AT503(A)-150-HR
539-163-□□	AT503(A)-200-HR
539-164-□□	AT503(A)-250-HR
539-165-□□	AT503(A)-300-HR
539-166-□□	AT503(A)-350-HR

* The □□ in the Order No. is as follows. AT503 : 30
AT503A: 31

Mounting dimensions (HL Type)

Unit: mm

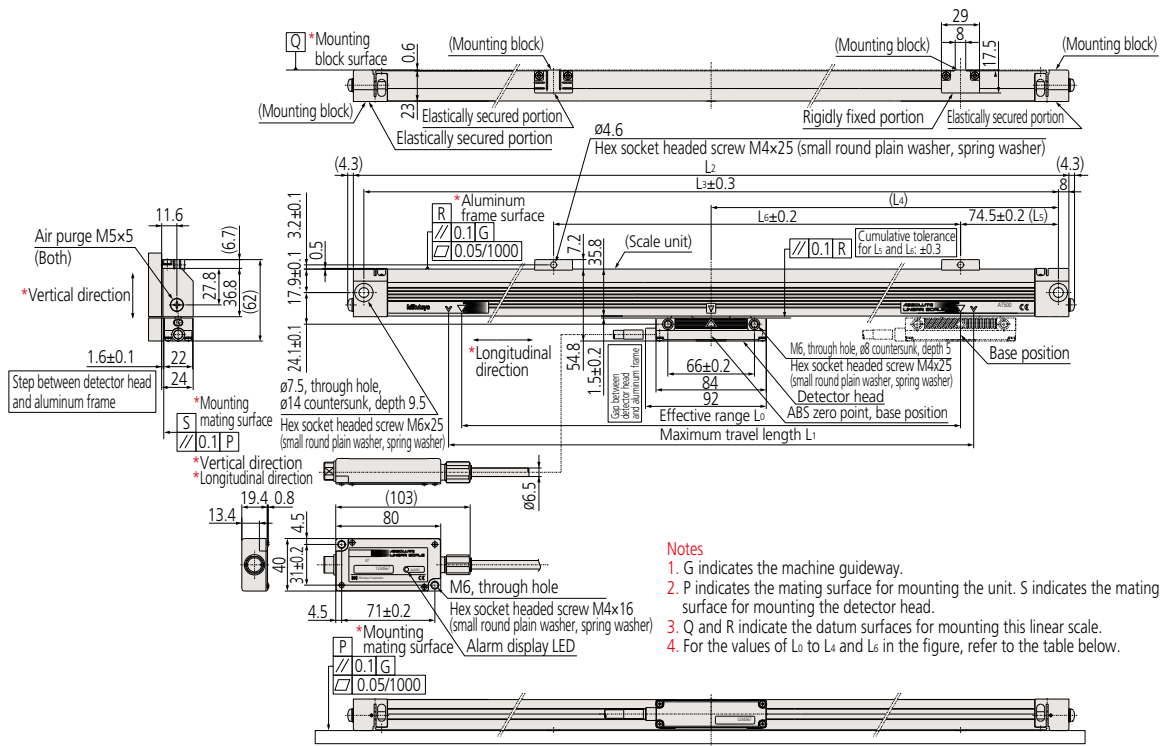

Dimensions

Effective range L ₀ (mm)	Maximum travel length L ₁ (mm)	Overall length L ₂ (mm)	Mounting pitch		
			L ₃ (mm)	L ₄ (mm)	L ₆ (mm)
100	120	265	249	124.5	—
150	170	315	299	149.5	100
200	220	365	349	174.5	130
250	270	415	399	199.5	160
300	320	465	449	224.5	190
350	370	515	499	249.5	220

Codes and Order Numbers

• ABS AT553-HL

Order No.	Code
539-761-40	AT553-100-HL
539-762-40	AT553-150-HL
539-763-40	AT553-200-HL
539-764-40	AT553-250-HL
539-765-40	AT553-300-HL
539-766-40	AT553-350-HL

• ABS AT543/AT543A-HL

Order No.	Code
539-731-□□	AT543(A)-100-HL
539-732-□□	AT543(A)-150-HL
539-733-□□	AT543(A)-200-HL
539-734-□□	AT543(A)-250-HL
539-735-□□	AT543(A)-300-HL
539-736-□□	AT543(A)-350-HL

* The □□ in the Order No. is as follows. AT543 : 40
AT543A: 41

• ABS AT573A-HL

Order No.	Code
539-871-41	AT573A-100-HL
539-872-41	AT573A-150-HL
539-873-41	AT573A-200-HL
539-874-41	AT573A-250-HL
539-875-41	AT573A-300-HL
539-876-41	AT573A-350-HL

• ABS AT503/AT503A-HL

Order No.	Code
539-161-□□	AT503(A)-100-HL
539-162-□□	AT503(A)-150-HL
539-163-□□	AT503(A)-200-HL
539-164-□□	AT503(A)-250-HL
539-165-□□	AT503(A)-300-HL
539-166-□□	AT503(A)-350-HL

* The □□ in the Order No. is as follows. AT503 : 40
AT503A: 41

ABS AT500 Series

Structural Features

- **ABS AT500-S Series** combines high vibration resistance with shock resistance

1. Example of vibration resistance characteristics

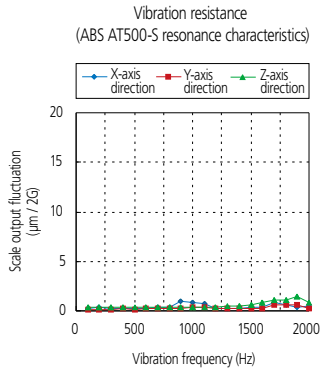

2. Vibration resistance

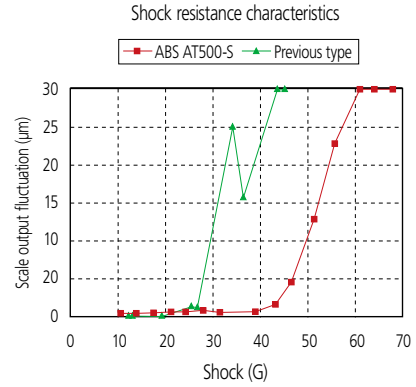

- **ABS AT500-H Series** combines outstanding thermal characteristics with high repeatability

1. Structural concept

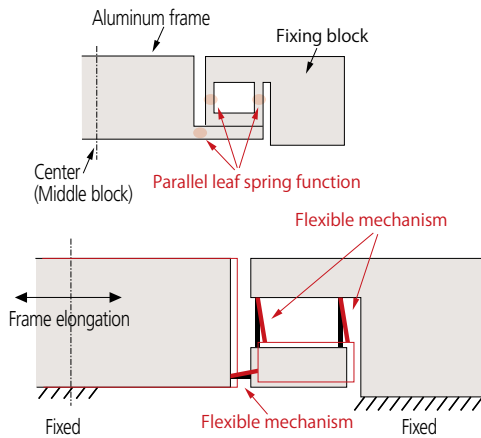

2. Example of thermal characteristics

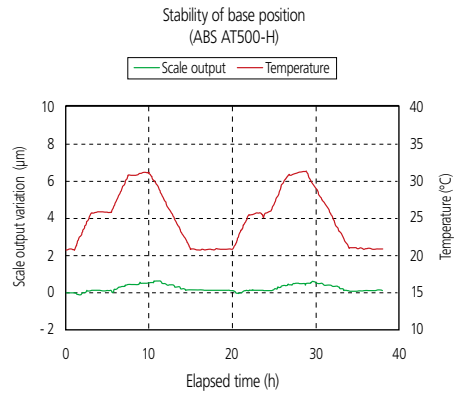

Note: This refers to the fixed point on the scale around which clamping arrangements ensure that any expansion or contraction due to temperature change occurs.

Discontinued models and succession models specification compatibility

△ : Compatible (with limitations)

Separate type ST scales

Discontinued models	Current model	Scale grating pitch	Output signal specifications	Accuracy	Mounting dimensions	Output connector specification pin assignment
ST31A, ST32A	ST36A	Yes	Yes	Yes	No	Yes
ST33C	ST36C	Yes	Yes	Yes	No	No
ST52B	ST46-EZA	Yes	Yes	Yes	No	No
ST62C	ST46-EZA	Yes	△*1	Yes	No	No
ST34C	ST36C	Yes	Yes	Yes	No	Yes
ST44B/ST44C	ST46-EZA	Yes	Yes	Yes	No	Yes
ST46	ST46-EZA	Yes	Yes	Yes	No	Yes
LHS21/23C	None	—	—	—	—	—

*1 Up/down pulse output cannot be supported.

Assembly type AT scales

Discontinued models	Current model	Scale grating pitch	Output signal specifications	Accuracy	Mounting dimensions	Output connector specification pin assignment
AT2-N	AT103	Yes	△*2	Yes	Yes	△*2
AT2-FN		Yes	△*2	Yes	Yes	△*2
AT11-N	AT113	Yes	△*2	Yes	Yes	△*2
AT11-FN		Yes	△*2	Yes	Yes	△*2
AT12-N	AT112	Yes	△*2	Yes	Yes	△*2
AT12		Yes	△*2	Yes	Yes	△*2
AT81-C	None	Yes	No	△*3	Yes	No
AT21-C	AT211	Yes	△*4	△*3	No	No
AT21		No	△*4	△*3	No	No
AT25	AT211	No	△*4	△*3	No	No
AT102	AT103	Yes	Yes	Yes	Yes	Yes
AT111	AT113	Yes	Yes	Yes	Yes	Yes
AT181	None	—	—	—	—	—
AT212	AT211	Yes	Yes	△*3	No	No

*2 This can only be supported with an adapter when connected to an old counter.

*3 This must be checked for each scale effective range.

*4 Compatible with the output signal of the pulse signal unit

TIP: Refer to the Linear Scale DRO Systems for AT103/AT112-F/AT113 (Catalog No. E13000).

Absolute scale unit

Discontinued models	Current model	Interface	Resolution	Maximum response speed	Mounting dimensions	Output connector specification pin assignment
AT3□2	ABS AT3□3	Yes	△*5	Yes	No	△*6
AT500 series	ABS AT500-S series	Yes	Yes	Yes	No	△*7
	ABS AT500-H series	Yes	Yes	Yes	No	△*7

*5 You can control this by changing the NC parameter settings. For details, contact your NC manufacturer.

*6 Check that pins No. 9 and 10 of the AT353 output connector are not connected before you make the connection.

*7 The AT543A is compatible. Other current models have discrete-wire specifications.

Handling linear scales

Mounting scales

1. AT scale mounting posture

The scale unit is designed so that it is difficult for contamination to enter the unit, but determine the mounting posture after considering the arrival directions of coolant and dust so that these substances do not come into direct contact with the aperture. Also, be sure to prepare a scale cover.

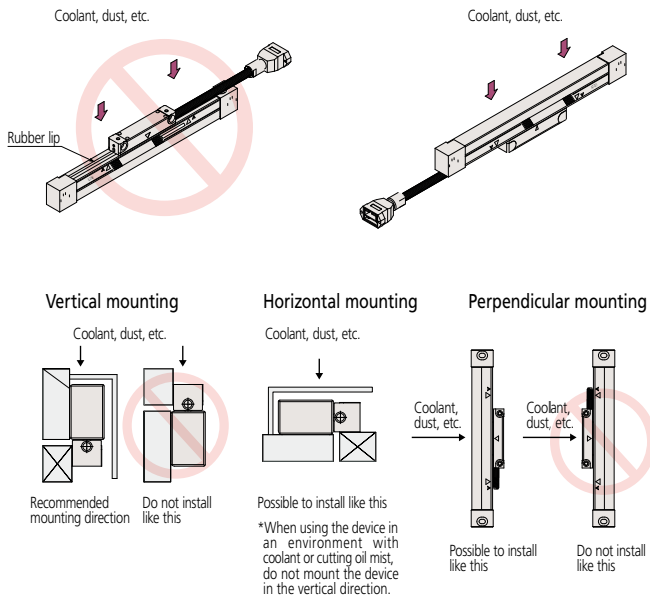

2. Mounting the AT scale unit

As shown in the following figure, use dial gauges or similar devices close to the two effective range marks to check and adjust their parallelism with the machine guideway.

To adjust the parallelism: (1) move the mechanically movable parts such as the slide table to adjust the parallelism of the scale unit or (2) measure the position from the mechanism's guide rail or from a corresponding reference.

- Permissible parallelism value: Less than 0.1mm or less than 0.2mm (This varies depending on the scale model.)

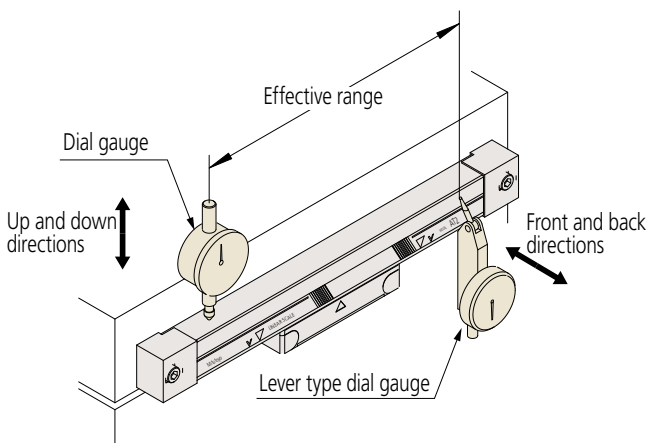

3. Cautions regarding mounting the ST scale (excluding the ABS ST700)

- Mount the main scale so that the detector head is facing the scale front surface (the surface on which rainbow colors are visible when light strikes the surface at an angle). (Models that have the Mitutoyo logo on the main scale are mounted correctly when the logo can be read from the detector head side.)
- Ambient light entering from the back of the main scale will cause incorrect operation, so the scale mounting design must ensure that ambient light does not enter.

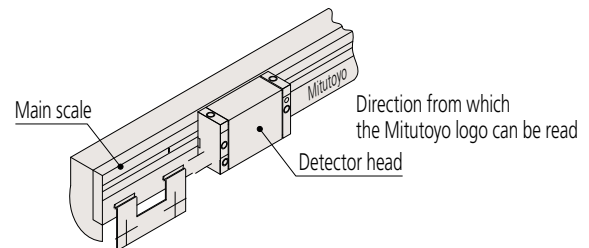

- Use a tool such as a lever type indicator or dial gage to move the head bracket and the scale mounting relatively in order to check whether the scale mounting surface has been prepared as shown in the mounting diagram.
- Use flexible adhesive with adhesive type scales. We recommend that you use KE441T manufactured by Shin-Etsu Chemical Co, Ltd.
- Remove the protective tape attached to the glass scale and detector head when you install the device.

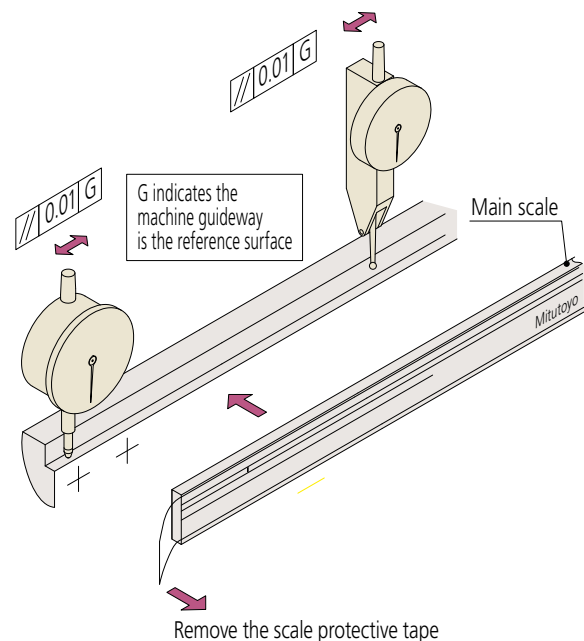

Specifications of Air Supply Unit for AT Scale

Supplying clean compressed air to the scale unit is important as a means of improving the environmental resistance (resistance to coolant and dust ingress) of assembly-type linear scales. Provide piping to either of the two M5 screw holes situated on both sides of the scale unit to enable compressed air delivery.

Note: **AT211** (multipoint fixed), **AT203**, **ABS AT500 series**, **AT1100 series** and **AT402E** are standard equipped with the air supply connector.

Note: This air supply method is an auxiliary measure. The orientation of air-supply piping is a matter of importance. Observe the piping orientation described in the manual to implement piping. After the air supply has been started, the air filter must be replaced periodically depending on the degree of contamination of the air source to be used. If a contaminated filter continues to be used this will allow contamination of the scale unit, resulting in failure.

1. Air quality specifications

ISO 85731-1 Class 1.4.1 or equivalent

Maximum particle diameter (µm)	0.1
Minimum-pressure dew point (°C)	+3
Oil concentration (mg/m ³)	0.01

2. Air flow rate 10 to 20 L/min (per axis)

IMPORTANT: This flow rate should be maintained to the degree that air leaks out slightly past the dustproof rubber.

2.1 Using the Mitutoyo-spec fixed reducer (fixed reducer diameter: ø0.9)

Adjust air pressure so that the air flow rate becomes 10 to 20 L/min (per axis). (TIP) When air pressure is 0.1 MPa for one axis, the airflow rate will be approx. 12.7 L/min.

When air pressure is 0.2 MPa, the airflow rate will be approx. 19 L/min.

2.2 Using any other fixed reducer

Adjust air pressure so that the air flow rate becomes 10 to 20 L/min (per axis). For the relation between flow rate and air pressure, refer to the flow rate characteristics (relation between flow rate depending on fixed reducer diameter and pressure) published by pneumatic device makers.

2.3 Using a flow regulating valve

Adjust air pressure so that the air flow rate becomes 10 to 20 L/min (per axis). However, be careful not to supply a large flow of air before adjustment. Otherwise damage may occur, resulting in a failure.

3. Air Supply Unit

[For a typical linear scale]

Be sure to use dry compressed air through an air dryer and a main line air filter without directly supplying air from the compressor. Replace each filter element every year. Mount the fixed reducer on the scale side.

• CKD Corporation air supply unit

Air dryer and main line air filter

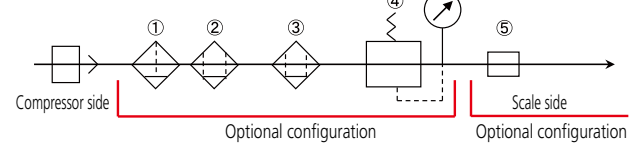

[For ABS AT1100 series]

The ABS AT1100 series does not need an air dryer and a high-performance oil mist filter. Be sure to use dry compressed air through a main line air filter without directly supplying air from the compressor.

• CKD Corporation air supply unit

Main line air filter

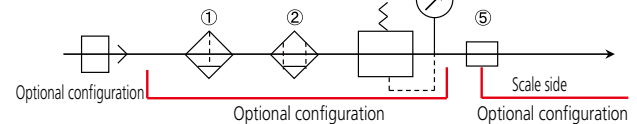

No.	Configuration element	Specifications	Part No.	
			Order No. (Mitutoyo)	Maker's model No. (Maker name)
①	Air filter	<ul style="list-style-type: none"> Used fluid: Compressed air Maximum allowable working pressure: 1.0MPa Guaranteed safe pressure: 1.5MPa Maximum particle diameter (filterability): 5µm Secondary oil concentration: — 	—	F1000-8-W (CKD)
②	Oil mist filter	<ul style="list-style-type: none"> Used fluid: Compressed air Maximum allowable working pressure: 1.0MPa Guaranteed withstanding pressure: 1.5MPa Maximum particle diameter (filterability): 5µm Secondary oil concentration: 0.01mg/m³ or less Element replacement: Every year (6000 hours) or upon pressure drop of 0.1MPa 	—	M1000-8-W (CKD)
③	High-performance oil mist filter	<ul style="list-style-type: none"> Used fluid: Compressed air Maximum allowable working pressure: 1.0MPa Guaranteed safe pressure: 1.5MPa Maximum particle diameter (filterability): 5µm Secondary oil concentration: 0.001mg/m³ or less Element replacement: Every year (6000 hours) or upon pressure drop of 0.1MPa 	—	MX1000-8-W (CKD)
④	Regulator	<ul style="list-style-type: none"> Used fluid: Compressed air Maximum allowable working pressure: 1.0MPa Guaranteed withstanding pressure: 1.5MPa Settable pressure range: 0.1 to 0.7MPa Banned-oil processing type 	—	RA-050-L (CKD)
⑤	Fixed reducer	<ul style="list-style-type: none"> Used fluid: Air Usable pressure range: 0.1 to 0.9MPa Screw clamping torque: 1.0 to 1.5N·m Flow rate at pressure of 0.1MPa: Approx. 12.7L/min Flow rate at pressure of 0.2MPa: Approx. 19L/min (per axis) 	06AC155	PC6-M5M-0.9 (Pisco custom-made part)
① to ④	Air unit (① Air filter + ② Oil mist filter + ③ High-performance oil mist filter + ④ Regulator)	<ul style="list-style-type: none"> ISO -8573-1 Class 1.4.1 or equivalent Maximum particle diameter (filterability): 0.01µm Minimum pressure dew point: — Oil concentration (oil mist concentration): 0.001mg/m³ or less Pressure: Flow rate at pressure of 0.1MPa: 12.7L/min (per axis) Maximum air flow rate: 75 L/min Replacement cycle of each filter element: Yearly 	06AC154	—

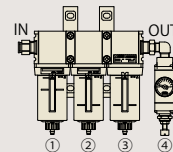

• Air Unit Dimensions

Unit: mm

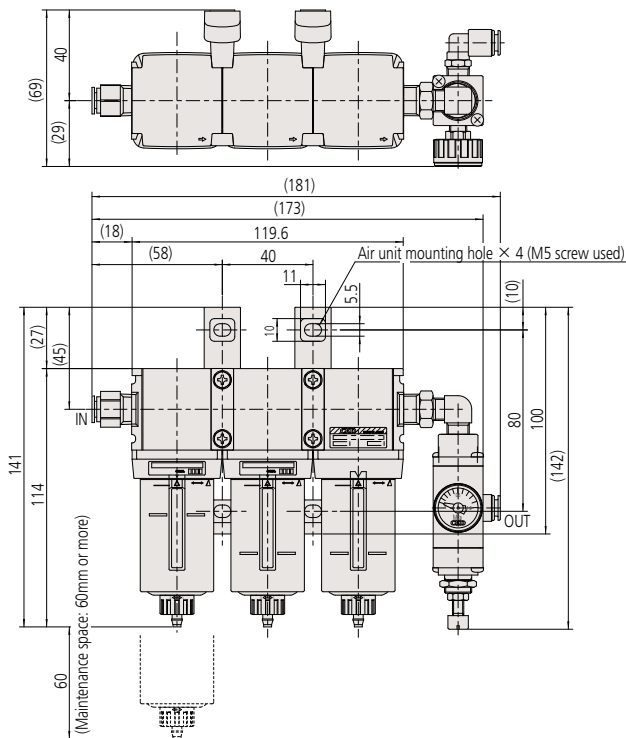

4. Connection Method

Be sure to use dry compressed air through an air dryer and a main line air filter without directly supplying air from the compressor. Also, mount the fixed reducer on the scale side.

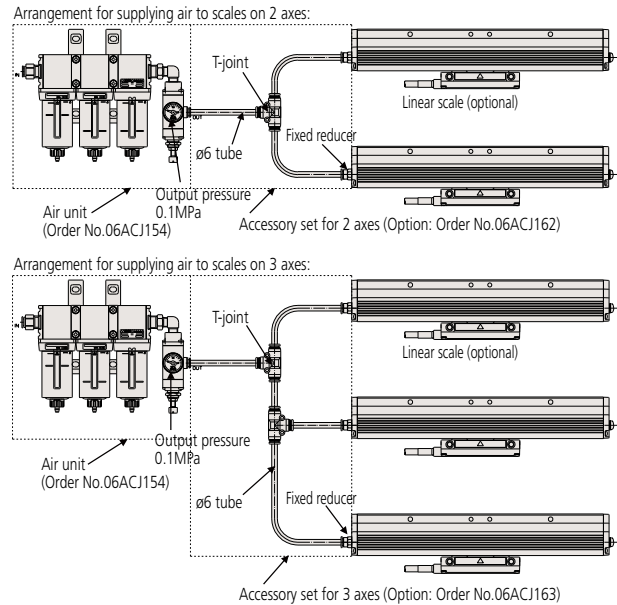

Note: One air supply unit allows connection of scales on up to 5 axes. Accessory sets for 2 axes and 3 axes are available. The combination of these 2 sets allows a maximum 4 or 5 axes to be connected. $\phi 6$ air tubes 20m in length are supplied with each accessory set. Supply air to each linear scale for approx. 30 minutes prior to use. It is also recommended to supply air to each scale for approx. 30 minutes after use to provide further protection to the scale.

5. Air Supply Unit Configuration and Maintenance Parts

Order No.	Name / Packaged items	Remarks
06ACJ154	Air unit (Appendix ① to ④)	
06ACJ162	Accessory set for 2 axes / Fixed reducer: 2 pcs, $\phi 6$ urethane tube: 20m, T-joint (2 pcs, one is a spare)	Optional accessory (extra-cost)
06ACJ163	Accessory set for 3 axes / Fixed reducer: 3 pcs, $\phi 6$ urethane tube: 20m, T-joint (3 pcs, one is a spare)	
06ACJ155	Fixed reducer / PC6-M5M-0.9 or equivalent (Appendix ⑤)	
06ACJ159*1	Air filter element (CKD) / F1000-ELEMENT-ASSY (for the first step)	Maintenance parts (extra-cost)
06ACJ160*1	Mist separator element (CKD) / M1000-MANTLE-ASSY (for the second step)	
06ACJ161*1	Micro-mist separator element (CKD) / MX1000-MANTLE-ASSY (for the third step)	

* 1: Replace the elements of 06ACJ159, 06ACJ160 and 06ACJ161 every year.

The replacement cycle differs depending on the usage and circumstances.

Note: For the maintenance method, confirm with the User's Manual supplied with the scale unit.

Technical Information

Structure and features of the assembly type linear scale (AT)

1. AT series detector joint mechanism (Adoption of simple joint structure offering high rigidity)

The detector head and slider (sensor) of the scale unit are connected by the joint shown in the following figure. Because of this structure, if values are less than or equal to the scale mounting standard values, detector head mounting errors and parallelism differences between the scale unit and the machine guideway are absorbed, and normal operation is assured. Also, the simple and highly rigid structure provides superior durability.

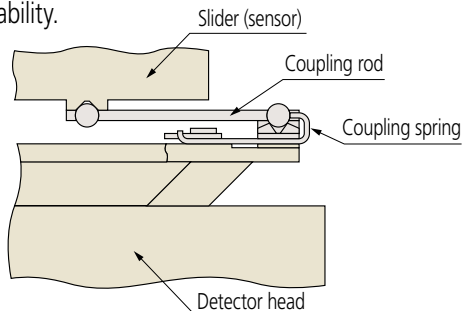

2. Advantage of special waterproof connectors

Adopting waterproof and oilproof connectors makes it possible to separate the signal cable. In turn, this makes installation and maintenance easy.

3. Signal cable conduit

Signal cables that are enclosed in a stainless-steel, spiral cover (conduit), for protection, are also available. The conduit will not rust or corrode, so these signal cables can be used over an extended period.

4. Adoption of rubber lip thrust method (Mitutoyo's proprietary technology)

The thrust part (see the following figure) pushes aside the rubber seal like a ship's keel pushes aside water.

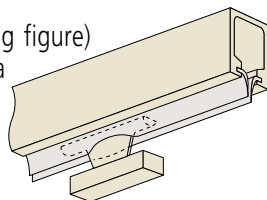

5. Adoption of specially formed urethane rubber lip with reinforcing wire

Resistance to oil and dust has been improved.

*Available with the AT103, AT203, ABS AT500, and ABS AT300.

*Can be specially ordered for the AT113 and AT211.

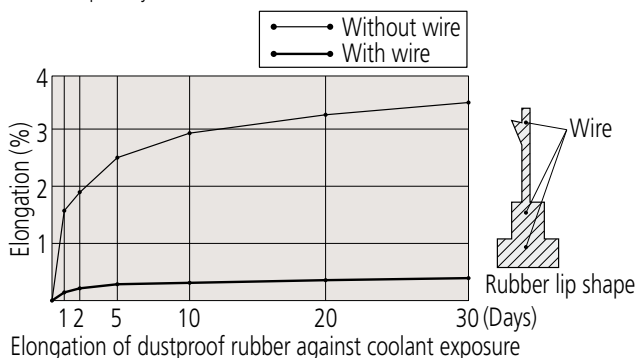

6. Maintenance of the seal

To maintain the dustproof property of the rubber seal and extend its life, apply a small amount of good-quality silicone grease (such as G-30L made by Shin-Etsu Chemical Co, Ltd.) to the contacting area of the rubber and detector head once a year. (The maintenance interval will vary slightly according to the operating conditions of the scale.)

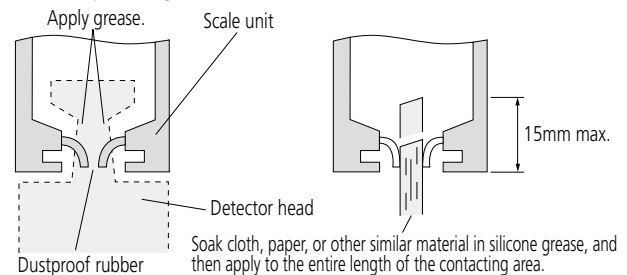

Durability of cables used with the linear scale

The life expectancy of the linear scale cables has been tested using the methods shown below.

Test method A

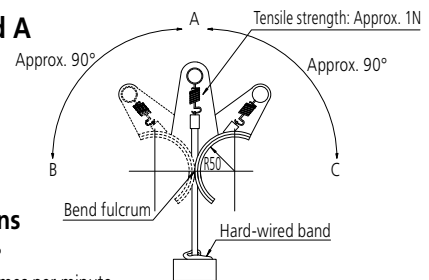

Test conditions

Bend angle: $\pm 90^\circ$

Test speed: 30 times per minute

(For the number of bends, A, B, A, C, and then A represents one bend.)

Bend radius: $R = 50\text{mm}$

Evaluation standard value: 3,000,000 times

(No breaks in the signal wires or shield)

Test method B

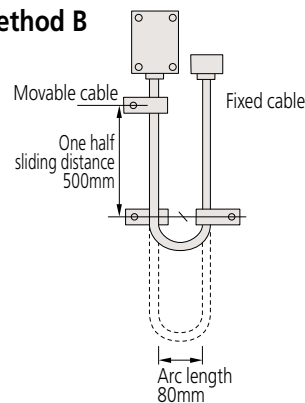

Test conditions

Bend radius: $R = 40\text{mm}$

Speed: 2m/s

Travel distance: 1000mm

Scales	Test method	Signal cable test result*1
AT100 series	A	3 million times
AT211	A	3 million times
AT203	A	3 million times
AT300 series	A	3 million times
AT500 series	A	3 million times
ST700 series	B	96 million times or more*2
ST36	B	96 million times or more*2
ST24	B	54 million times or more*2
ST422	A	96 million times
ST46	B	59 million times

*1 Also including the head cable

*2 Testing still ongoing as of September 2016

Note 1: The test data stated above does not represent guaranteed values. Depending on the bend conditions, the number of times that the cables can bend without failure may be less than indicated.

Note 2: When bending cables, the recommended bend radius is 100mm or more.

Alarm functions

1. Detection of detector disconnection and short-circuit errors

Disconnection of and short circuits to 0V of the phase A and phase B signal lines from the linear scale as well as other similar errors are detected.

2. Detection of excess response speed of detector feed (over-speed)

The feed speed of the linear scale (detector) exceeding the maximum feed speed as well as other similar errors are detected.

3. Detection of input signal errors

The amplitude voltage, DC voltage, or phase difference of the phase A and phase B signals from the linear scale being outside of the corresponding allowable range as well as other similar errors are detected.

4. Drop in line voltage

The line voltage supplied to the linear scale, PSU, and other devices (particularly devices that use a DC power supply) dropping below the allowable range is detected as an error.

5. Detection of momentary power failures

A momentary power failure or voltage drop greater than the allowable range occurring in the power supply that is being supplied to the PSU, counter, or other device (devices that use an AC power supply) is detected as an error.

6. Detection of scale errors

Errors that occur inside the linear scale are detected.

7. Detection of detector circuit errors

Errors caused by the incremental count or absolute count in absolute linear scales are detected.

8. Detection of CPU errors (detection of internal errors)

For linear scales, counters, and other devices that use CPUs, the CPU stopping operating normally is detected as an error.

Note: The alarm functions vary according to the product. For details, see the alarm functions available with each product. Also note that the allowable ranges used to detect alarms vary according to the product.

Alarm detection functions available with each product

(1) Alarm functions on the AT scales (sinusoidal signal output type) + PSU-200



Scale code	Alarm function				
	Detected inside the scale			Detected inside the PSU	
	Scale error	Over-speed	Input signal error	Detection of scale errors	Disconnection or short circuit in signal cable
AT103	Yes				
AT113	Yes				
AT112	No				
PSU-200		Yes	Yes	Yes	Yes
PSU-250 series		Yes	Yes	Yes	Yes

(2) Alarm functions on the AT scales (square wave signal output type)

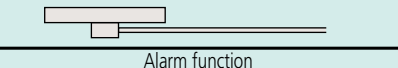

Scale code	Alarm function	
	Detected inside the detector head (inside the I/F on the AT212)	
	Over-speed	Input signal error
AT203	Yes	Yes
AT211	Yes	Yes

(3) Alarm functions on the ST scales (sinusoidal signal output type) + PSU-200



Scale code	Alarm function				
	Detected inside the scale			Detected inside the PSU	
	Scale error	Over-speed	Input signal error	Detection of scale errors	Disconnection or short circuit in signal cable
ST36A	Yes				
ST24	Yes				
PSU-200		Yes	Yes	Yes	Yes
PSU-250 series		Yes	Yes	Yes	Yes

(4) Alarm functions on the ST scales (square wave signal output type)

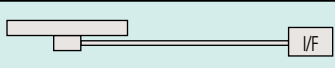

Scale code	Alarm function		
	Detected inside the I/F		
	Ove-speed	Input signal error	Disconnection or short circuit in signal cable
ST24B(C)	Yes	Yes	Yes
ST36	Yes	Yes	Yes
ST422	Yes	Yes	Yes
ST46-EZA	Yes	Yes	Yes

(5) Alarm functions on the absolute scales

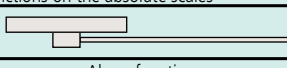

Scale code	Alarm function				
	Detected inside the I/F				
	Scale error	Over-speed	Input signal error	Detector circuit error	CPU error
ABS ST700 series	Yes	Yes	Yes	Yes	Yes
ABS ST1300 series	Yes	Yes	Yes	Yes	Yes
ABS AT300 series	Yes	Yes	Yes	Yes	Yes
ABS AT500 series	Yes	Yes	Yes	Yes	Yes
ABS AT1100 series	Yes	Yes	Yes	Yes	Yes

Explanation of terms

Linear scale accuracy

(1) Linear scale accuracy

As shown in Figure 1, the linear scale accuracy is determined by using an accuracy inspection device to perform comparisons at fixed intervals between the value measured with the linear scale and the reference value according to a laser length measuring device. The inspection environment temperature is 20°C, so the accuracy is at this temperature. The inspections are performed with other inspection conditions and standard values that comply with Mitutoyo's internal standards.

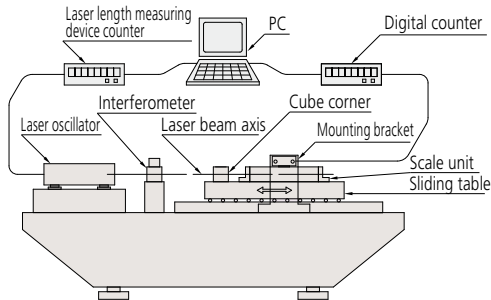

[Figure 1] Linear scale accuracy inspection device, overview

The accuracy (error) at each measured point is determined according to the following formula.

$$\text{Error} = \text{reference value of the laser length measuring device} - \text{value measured by the linear scale}$$

Here, the words "accuracy" and "error" have the same meaning.

We refer to the plot on a graph of the error at each measured point in the effective range as an accuracy chart.

Based on this accuracy chart, the accuracy of the linear scale is noted as the range between the maximum error and minimum error. There are the following two notation methods.

(1) Note the size of the range between the maximum error and minimum error as 'a'.

The value 'a' shown in Figure 2-1 indicates the accuracy. This standard value is indicated using the conversion formula $(\alpha + \beta L) \mu\text{m}$. Here, L is the effective range (in mm) and α and β are coefficients that are set on each model.

For example, for a linear scale with an accuracy standard value of $(3 + 3L/1000) \mu\text{m}$ and an effective range L of 1000mm, 'a' is $6\mu\text{m}$.

2) Note the size of the range between the maximum error and minimum error as '±a/2'.

The center value between the maximum error and minimum error is 0, the maximum value is noted as '+a/2', the minimum value is noted as '-a/2', and the size of the error range is noted as '±a/2'. This notation is mainly applied to ST scales.

In notations (1) and (2), 'a' in (1) and '±a/2' in (2) are the same accuracy standard value. Linear scales use a straight-line scale that has fixed-pitch graduations as the reference to detect the amount of movement and the amount of change in position. By detecting graduations, a linear scale obtains 2-phase sinusoidal signals that have the same pitch as the graduations. The linear scale is designed so that it can perform readings with greater detail than the straight-line scale by interpolating this sine wave signal with an electronic circuit. Interpolation means that these 2-phase sinusoidal signals are interpolated, and the result is divided into pulse signals corresponding to the resolution. For example, if the graduation pitch is $20\mu\text{m}$, readings can be performed with a resolution of $1\mu\text{m}$.

Here, error within the graduation pitch range will occur according to the accuracy of this interpolation processing. This is called interpolation accuracy.

The accuracy standard value of a linear scale includes the aforementioned errors inspected at fixed intervals and interpolation accuracy.

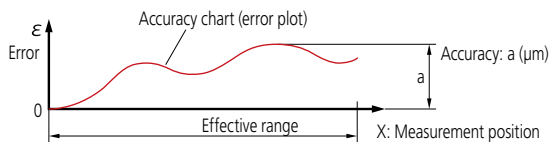

[Figure 2-1] Accuracy notation method (1)

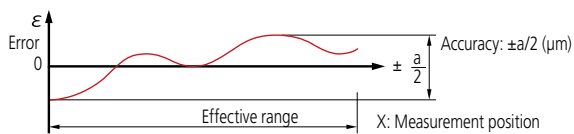

[Figure 2-1] Accuracy notation method (2)

Serial interface

This refers to a communication channel in which digital data is transmitted sequentially 1bit at a time. While it has inferior real-time characteristics, the advantages are that it requires less wiring and has high reliability. (This is the main communication method for feedback encoders.)

Line-driver output

This refers to signals that are output as square waves. A signal that has the inverted polarity of the output signal is generated, and the difference between these signals is set as the signal (differential signal output). This complies with EIA standards RS-422 and RS-485.

RS-422

This was standardized by the Electronic Industries Alliance (EIA) of the U.S. It is one of the balanced type serial communications standards, and it has excellent noise reducing characteristics. The maximum transmission speed is 10Mbps, but limitations on the transmission speed arise as the cable length increases.

RS-485

This was standardized by the Electronic Industries Alliance (EIA) of the U.S. It is one of the balanced type serial communications standards, and it ranks higher than RS-422. RS-422 is upwardly compatible with this standard. While RS-422 is a communication standard that supports point-to-point, multi-drop connections, this standard supports bus type multi-point connections and bidirectional communications.

Minimum edge interval

This refers to the minimum time between a rising edge or falling edge of a square wave being output (or input) and the next edge being output (or input). For square wave output type linear scales, even with the same resolution, the shorter the minimum edge interval, the faster the response speed.

Thermal expansion coefficient

This refers to the thermal expansion of an object in response to a change in temperature, which is measured as elongation per unit length for each 1°C increase in temperature of the material.

Full duplex communication and half duplex communication

Full duplex communication refers to a system in which devices (for example, a scale and a servo amplifier) each have two communication lines and can communicate with each other at the same time. On the other hand, half duplex communication refers to a system in which devices have a single communication line, so devices cannot communicate with each other at the same time, and communications can only be sent from a single device at any one time.

Full duplex communication

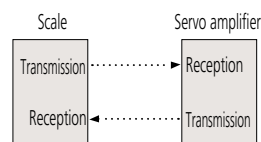

Half duplex communication

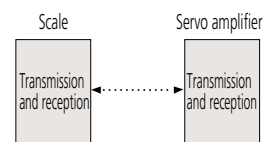

MEMO



Export permission by the Japanese government may be required for exporting our products according to the Foreign Exchange and Foreign Trade Law. Please consult our sales office near you before you export our products or you offer technical information to a nonresident.

- Coordinate Measuring Machines
- Vision Measuring Systems
- Form Measurement
- Optical Measuring
- Sensor Systems
- Test Equipment and Seismometers
- Digital Scale and DRO Systems
- Small Tool Instruments and Data Management

Note: All information regarding our products, and in particular the illustrations, drawings, dimensional and performance data contained in this pamphlet, as well as other technical data are to be regarded as approximate average values. We therefore reserve the right to make changes to the corresponding designs, dimensions and weights. The stated standards, similar technical regulations, descriptions and illustrations of the products were valid at the time of printing. Only quotations submitted by ourselves may be regarded as definitive. Our products are classified as regulated items under Japanese Foreign Exchange and Foreign Trade Law. Please consult us in advance if you wish to export our products to any other country. If the purchased product is exported, even though it is not a regulated item (Catch-All controls item), the customer service available for that product may be affected. If you have any questions, please consult your local Mitutoyo sales office.

Mitutoyo Corporation
 20-1, Sakado 1-Chome,
 Takatsu-ku, Kawasaki-shi,
 Kanagawa 213-8533, Japan
 T +81 (0) 44 813-8230
 F +81 (0) 44 813-8231
<http://www.mitutoyo.co.jp>

