

List 9580 (Continued)

PHX-PC-DFR, 3 Flute, Pencil Neck, Deep Feed, Corner Radius

SPEED FEED P1128-1130	CARBIDE	WXS		55°	SHANK h6
--------------------------	---------	-----	--	-----	-------------

Units: mm

EDP Number	Mill Diameter	Corner Radius	Overall Length	Length of Cut	Min. Neck Diameter	Maximum Neck Diameter	Neck Length	Effective Draft Angle	Neck Draft Angle	Shank Diameter	Type
	D	R	L	Lc	d1	d2	L1	α	β	d	
3098064	10	2.0	220	15.0	9.90	16.00	92.9	2.00°	2°	16	2
3098224	12	2.0	180	18.0	11.90	13.68	120.0	0.41°	0.5°	16	1
3098241	12	2.0	120	18.0	11.90	13.37	60.0	0.67°	1°	16	1
3098242	12	2.0	180	18.0	11.90	14.76	100.0	0.81°	1°	16	1
3098243	12	2.0	180	18.0	11.90	16.00	122.6	1.00°	1°	16	2
3098244	12	2.0	220	18.0	11.90	16.86	160.0	0.88°	1°	20	1
3098254	12	2.0	220	18.0	11.90	20.00	160.8	1.50°	1.5°	20	2

Packed: 1 pc.
Available WXS[®] coating only.

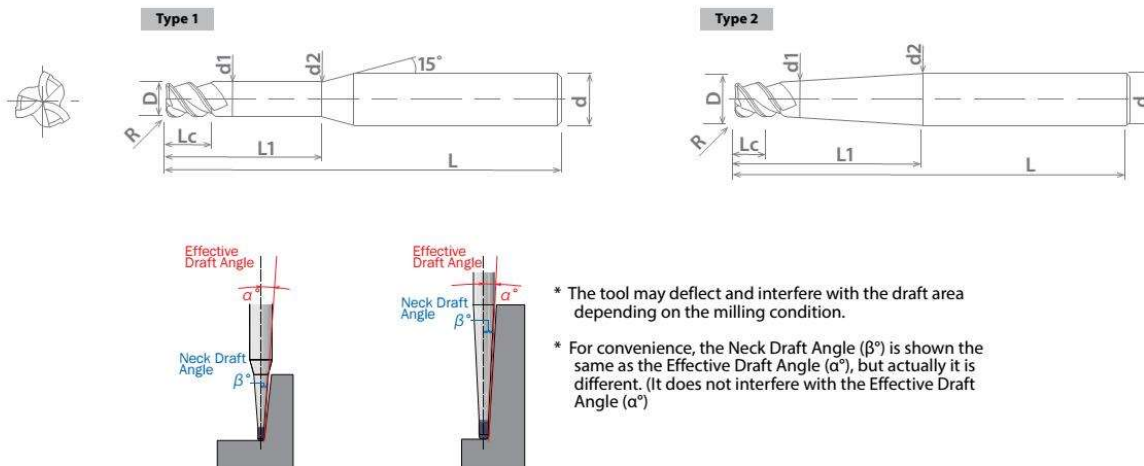

Work Material																
List No.	P					M			K	N		S	H			
	Carbon Steels			Alloy Steels	Die Steels	Stainless Steels			Cast Iron	Aluminum	Nickel Alloy	Titanium	Hardened Steels			
	Low	Med.	High	4140		4340	300	400		17-4 PH	6061	7075	Casting	Inconel	6Al4V (30 HRC)	~35 HRC
9580	<input type="checkbox"/>	<input type="checkbox"/>	<input type="checkbox"/>	<input type="checkbox"/>	<input type="checkbox"/>	<input type="checkbox"/>	<input type="checkbox"/>	<input type="checkbox"/>	<input type="checkbox"/>				<input type="checkbox"/>	<input type="checkbox"/>	<input type="checkbox"/>	<input type="checkbox"/>

good best

