



PROTO

**YOU'VE GOT TO PUT IN YOUR TIME
TO BE A MASTER TRADESMAN. SO DO YOUR TOOLS.**

Our plumbing and HVAC line includes master sets, by trade, featuring sockets, wrenches, pliers, screwdrivers, striking, cutting, and specialty tools. Just as important, these sets build on one another as you advance in your trade. So you can simply add a few tools or next-level sets without duplicating what you already own. Best of all, like every tool in this catalog, our plumbing and HVAC tools are built to the highest industry standards and warranted to become grizzled, uber-efficient veterans like you.

PLUMBING AND HVAC TOOLS

3/4" INCH PROTO® 724SL



Heavy-Duty Cast Iron Pipe Wrenches

PROTO

105 PIECE BASIC TOOL SET

Product #: **JTS-0105HVAC**



- › 105 Pieces.
- › 3/8" Drive Tools.
- › Designed for fastener sizes 3/8" - 7/8".
- › Contains: 28 Sockets and Accessories, 26 Wrenches, 7 Striking and Struck Tools, 8 Pliers, 13 Screwdrivers, 23 Miscellaneous Tools.
- › Weight: 40.36 lbs.



Representative Image; Contents May Differ

Contents	Description
J5270A	Adapter, Universal Joint 3/8" DR
J86012	Chisel, Cold 1/2" Super Duty
J86058	Chisel, Cold 5/8" Super Duty
J5259	Extension, 3/8" DR 1-3/4"
J5260	Extension, 3/8" DR 3"
J5260-06	Extension, 3/8" DR 6"
20-001	Hacksaw, High Tension Low Profile 12"
15-809	Hacksaw, Metal Mini
54-016	Hammer, Ball Pein Hickory 16 oz.
J4980	Hex Key, 13 Piece Standard Set
J2108	Holder, Punch and Chisel
10-788	Knife, QuickChange™ Retractable Blade Utility
43-609	Level, FatMax® Xtreme™ Torpedo 9"
J2370	Mirror, Inspect Circle 7/8"
J9206H	Nut Driver, 3/16" Hollow Shaft
J9208H	Nut Driver, 1/4" Hollow Shaft
J9210H	Nut Driver, 5/16" Hollow Shaft
J9212H	Nut Driver, 3/8" Hollow Shaft

Contents	Description
J9216H	Nut Driver, 1/2" Hollow Shaft
J207G	Pliers, Diagonal Cutting with Grip 7-5/16"
J252G	Pliers, Hose Clamp with Grip 7-3/4"
J291NC	Pliers, Locking Straight 7"
J228G	Pliers, Needle-Nose Long Handle 7-25/32"
J240G	Pliers, Needle-Nose Long Reach 11-9/16"
J276G	Pliers, Slip-Joint with Grip 6-9/16"
J260SG	Pliers, Tongue and Groove 10-3/16" with Grip
J299	Pliers, Wire Stripper/Crimper 8-1/2"
J4029	Puller Set Box
J413/8	Punch, Center
J48018	Punch, Pin 1/8" Super Duty
J48316	Punch, Pin 3/16" Super Duty
J5249	Ratchet, 3/8" DR
28-240	Scraper, Flexible Nylon 1-1/4"
66-095	Screwdriver, Vinyl Grip
65-903	Screwdriver, Vinyl Grip Phillips® 3 PT x 3"
66-565P	Screwdriver, 6 Piece Stanley® Vinyl Grip





Contents	Description
J5212	Socket, 3/8" DR 3/8" 12 PT
J5214	Socket, 3/8" DR 7/16" 12 PT
J5216	Socket, 3/8" DR 1/2" 12 PT
J5218	Socket, 3/8" DR 9/16" 12 PT
J5220	Socket, 3/8" DR 5/8" 12 PT
J5222	Socket, 3/8" DR 11/16" 12 PT
J5224	Socket, 3/8" DR 3/4" 12 PT
J5226	Socket, 3/8" DR 13/16" 12 PT
J5228	Socket, 3/8" DR 7/8" 12 PT
J5012	Socket, 3/8" DR 3/8" 12 PT Deep
J5014	Socket, 3/8" DR 7/16" 12 PT Deep
J5016	Socket, 3/8" DR 1/2" 12 PT Deep
J5018	Socket, 3/8" DR 9/16" 12 PT Deep
J5020	Socket, 3/8" DR 5/8" 12 PT Deep
J5022	Socket, 3/8" DR 11/16" 12 PT Deep
J5024	Socket, 3/8" DR 3/4" 12 PT Deep
J5026	Socket, 3/8" DR 13/16" 12 PT Deep
J5028	Socket, 3/8" DR 7/8" 12 PT Deep
J7210PF	Socket, Power 3/8" DR 5/16" Magnetic
J7212PF	Socket, Power 3/8" DR 3/8" Magnetic
J7214PF	Socket, Power 3/8" DR 7/16" Magnetic
J7216PF	Socket, Power 3/8" DR 1/2" Magnetic
J7218PF	Socket, Power 3/8" DR 9/16" Magnetic
33-725	Tape Rule, FatMax® 1-1/4" x 25'
518160M	Tote, Stanley® FatMax® 18"
J350	Tubing Cutter
J351	Tubing Flaring Tool
J708G	Wrench, Adjustable 8" Grip

Contents	Description
J712G	Wrench, Adjustable 12" Grip
J812HD	Wrench, Pipe 12"
J1111	Wrench, Ratchet Refrigeration, 1/4" - 3/16" Sq. x 9/16"
J1112	Wrench, Ratchet Refrigeration, 3/8" - 5/16" Sq. x 1/4"
J1208A	Wrench, Combination 1/4" 12 PT
J1210A	Wrench, Combination 5/16" 12 PT
J1212ASD	Wrench, Combination 3/8" 12 PT
J1214ASD	Wrench, Combination 7/16" 12 PT
J1216ASD	Wrench, Combination 1/2" 12 PT
J1218ASD	Wrench, Combination 9/16" 12 PT
J1220ASD	Wrench, Combination 5/8" 12 PT
J1222ASD	Wrench, Combination 11/16" 12 PT
J1224ASD	Wrench, Combination 3/4" 12 PT
J1226ASD	Wrench, Combination 13/16" 12 PT
J1228ASD	Wrench, Combination 7/8" 12 PT
J3764	Wrench, Flare Nut 3/8" x 7/16" 6 PT
J3768	Wrench, Flare Nut 1/2" x 9/16" 6 PT
J3772	Wrench, Flare Nut 5/8" x 11/16" 6 PT
J3812	Wrench, Flare Nut Ratcheting 3/8"
J3814	Wrench, Flare Nut Ratcheting 7/16"
J3816	Wrench, Flare Nut Ratcheting 1/2"
J3818	Wrench, Flare Nut Ratcheting 9/16"
J3820	Wrench, Flare Nut Ratcheting 5/8"
J3822	Wrench, Flare Nut Ratcheting 11/16"
J3824	Wrench, Flare Nut Ratcheting 3/4"

70 PIECE STARTER TOOL SET

Product #: **JTS-0070HVAC**



- ▶ 70 Pieces.
- ▶ Contains: 19 Wrenches, 7 Striking and Struck Tools, 8 Pliers, 12 Screwdrivers, 24 Miscellaneous Tools.
- ▶ Weight: 45 lbs.



Representative Image; Contents May Differ

Contents	Description
J86012	Chisel, Cold 1/2" Super Duty
J86058	Chisel, Cold 5/8" Super Duty
20-001	Hacksaw, High Tension Low Profile 12"
15-809	Hacksaw, Metal Mini
54-016	Hammer, Ball Pein Hickory 16 oz.
J4980	Hex Key, 13 Piece Standard Set
J2108	Holder, Punch and Chisel
10-788	Knife, Utility QuickChange™ Retractable Blade
43-609	Level, FatMax® Xtreme™ Torpedo 9"
J2370	Mirror, Inspect Circle 7/8"
J9208H	Nut Driver, 1/4" Hollow Shaft
J9210H	Nut Driver, 5/16" Hollow Shaft
J9212H	Nut Driver, 3/8" Hollow Shaft
J9216H	Nut Driver, 1/2" Hollow Shaft
J207G	Pliers, Diagonal Cutting with Grip 7-5/16"
J252G	Pliers, Hose Clamp with Grip 7-3/4"
J291NC	Pliers, Locking Straight 7"
J228G	Pliers, Needle-Nose Long Handle 7-25/32"
J240G	Pliers, Needle-Nose Long Reach 11-9/16"
J276G	Pliers, Slip-Joint with Grip 6-9/16"
J260SG	Pliers, Tongue and Groove 10-3/16" with Grip
J299	Pliers, Wire Stripper/Crimper 8-1/2"
J4029	Puller Set Box
J413/8	Punch, Center
J48018	Punch, Pin 1/8" Super Duty
J48316	Punch, Pin 3/16" Super Duty
28-240	Scraper, Flexible Nylon 1-1/4"

Contents	Description
66-095	Screwdriver, Vinyl Grip
65-903	Screwdriver, Vinyl Grip Phillips® 3 PT x 3"
66-565P	Screwdriver, 6 Piece Stanley® Vinyl Grip
33-725	Tape Rule, FatMax® 1-1/4" x 25'
518160M	Tote, Stanley® FatMax® 18"
J350	Tubing Cutter
J351	Tubing Flaring Tool
J708G	Wrench, Adjustable, 8" Grip
J712G	Wrench, Adjustable, 12" Grip
J1208A	Wrench, Combination 1/4" 12 PT
J1210A	Wrench, Combination 5/16" 12 PT
J1212ASD	Wrench, Combination 3/8" 12 PT
J1214ASD	Wrench, Combination 7/16" 12 PT
J1216ASD	Wrench, Combination 1/2" 12 PT
J1218ASD	Wrench, Combination 9/16" 12 PT
J1220ASD	Wrench, Combination 5/8" 12 PT
J1222ASD	Wrench, Combination 11/16" 12 PT
J1224ASD	Wrench, Combination 3/4" 12 PT
J1226ASD	Wrench, Combination 13/16" 12 PT
J1228ASD	Wrench, Combination 7/8" 12 PT
J3764	Wrench, Flare Nut 3/8" x 7/16" 6 PT
J3768	Wrench, Flare Nut 1/2" x 9/16" 6 PT
J3772	Wrench, Flare Nut 5/8" x 11/16" 6 PT
J812HD	Wrench, Pipe 12"
J1111	Wrench, Ratchet Refrigeration, 1/4" - 3/16" Sq. x 9/16"
J1112	Wrench, Ratchet Refrigeration, 3/8" - 5/16" Sq. x 1/4"



35 PIECE HVAC ADD-ON SET

Product #: JTS-0035HVAC



- › 35 Pieces.
- › 3/8" Drive Tools.
- › Designed for fastener sizes 3/8" - 7/8".
- › Tools only.
- › Contains: 28 Sockets and Accessories, 7 Wrenches.
- › Weight: 7 lbs.



Representative Image; Contents May Differ

Contents	Description
J5270A	Adapter, Universal Joint 3/8" DR
J5259	Extension 3/8" DR, 1-3/4"
J5260	Extension, 3/8" DR 3"
J5260-06	Extension, 3/8" DR 6"
J5249	Ratchet, 3/8" DR
J5212	Socket, 3/8" DR 3/8" 12 PT
J5214	Socket, 3/8" DR 7/16" 12 PT
J5216	Socket, 3/8" DR 1/2" 12 PT
J5218	Socket, 3/8" DR 9/16" 12 PT
J5220	Socket, 3/8" DR 5/8" 12 PT
J5222	Socket, 3/8" DR 11/16" 12 PT
J5224	Socket, 3/8" DR 3/4" 12 PT
J5226	Socket, 3/8" DR 13/16" 12 PT
J5228	Socket, 3/8" DR 7/8" 12 PT
J5012	Socket, 3/8" DR 3/8" 12 PT Deep
J5014	Socket, 3/8" DR 7/16" 12 PT Deep
J5016	Socket, 3/8" DR 1/2" 12 PT Deep
J5018	Socket, 3/8" DR 9/16" 12 PT Deep

Contents	Description
J5020	Socket, 3/8" DR 5/8" 12 PT Deep
J5022	Socket, 3/8" DR 11/16" 12 PT Deep
J5024	Socket, 3/8" DR 3/4" 12 PT Deep
J5026	Socket, 3/8" DR 13/16" 12 PT Deep
J5028	Socket, 3/8" DR 7/8" 12 PT Deep
J7210PF	Socket, Power 3/8" DR 5/16" Magnetic
J7212PF	Socket, Power 3/8" DR 3/8" Magnetic
J7214PF	Socket, Power 3/8" DR 7/16" Magnetic
J7216PF	Socket, Power 3/8" DR 1/2" Magnetic
J7218PF	Socket, Power 3/8" DR 9/16" Magnetic
J3812	Wrench, Flare Nut Ratcheting 3/8"
J3814	Wrench, Flare Nut Ratcheting 7/16"
J3816	Wrench, Flare Nut Ratcheting 1/2"
J3818	Wrench, Flare Nut Ratcheting 9/16"
J3820	Wrench, Flare Nut Ratcheting 5/8"
J3822	Wrench, Flare Nut Ratcheting 11/16"
J3824	Wrench, Flare Nut Ratcheting 3/4"



37 PIECE PLUMBER'S TOOL SET

Product #: **JTS-0037PLUM**



- › 37 Pieces.
- › Contains: 10 Wrenches, 5 Striking and Struck Tools, 6 Pliers, 4 Screwdrivers, 12 Miscellaneous Tools.
- › Enhanced version of Proto® 90-731 Plumber's Tool Set.
- › Weight: 41 lbs.



Representative Image; Contents May Differ

Contents	Description
95-112W	Flashlight, Stanley® Tripod - 20 Lumens
20-001	Hacksaw, High Tension Low Profile 12"
15-809	Hacksaw, Metal Mini
54-732	Hammer, Ball Pein Jacketed Graphite 32 oz.
51-505	Hammer, Jacketed Graphite Nailing CC - 16 oz.
10-788	Knife, Utility QuickChange™ Retractable Blade
43-609	Level, FatMax® Xtreme™ Torpedo 9"
J294WRXL	Pliers, Locking Curved Jaw with Cutter 7-15/32"
J240G	Pliers, Needle-Nose Long Reach 11-9/16"
J276G	Pliers, Slip-Joint with Grip 6-9/16"
J260SG	Pliers, Tongue and Groove 10-3/16" with Grip
J265SG	Pliers, Tongue and Groove 16" with Grip
20-556	Saw, FatMax® Jab
15-334	Saw, Sharptooth™ 15" 9 PT
62-559	Screwdriver, Prodriver™ Phillips® 3" x #1
62-561	Screwdriver, Prodriver™ Phillips® 4" x #2
62-553	Screwdriver, Prodriver™ Std 1/4" x 4"

Contents	Description
62-555	Screwdriver, Prodriver™ Std 5/16" x 6"
16-298	Chisel, 3 Piece Stanley® Cold Chisel Set
14-563	Snip, Aviation MaxSteel® Straight
33-725	Tape Rule, FatMax® 1-1/4" x 25'
518160M	Tote, Stanley® FatMax® 18"
J350	Tubing Cutter
J351	Tubing Flaring Tool
J708L	Wrench, Adjustable CliK-Stop® Chrome 8"
J712L	Wrench, Adjustable CliK-Stop® Chrome 12"
J801	Wrench, Chain
J806HD	Wrench, Pipe Heavy-Duty 6"
J810HD	Wrench, Pipe Heavy-Duty 10"
J814HD	Wrench, Pipe Heavy-Duty 14"
J140-38	Wrench, Pipe Internal 3/8"
J140-12	Wrench, Pipe Internal 1/2"
J140-34	Wrench, Pipe Internal 3/4"
J140-1	Wrench, Pipe Internal 1"





7 PIECE COMBINATION FLARE NUT WRENCH SET - 6 POINT

Product #: **J3700A**

- › Satin finish provides corrosion resistance and a slip-resistant grip.
- › Flare nut box end incorporates the TorquePlus™ system.
- › Weight (lbs): 2.24



Contents	Size (in)	Point Size	Overall Length (in)
J3751	3/8	6	5-11/16
J3752	7/16	6	6-1/32
J3753	1/2	6	6-7/16
J3754	9/16	6	6-15/16
J3755	5/8	6	7-5/8
J3756	11/16	6	8-11/16
J3757	3/4	6	9-3/16
J25TR03C	Tool Roll		



ASME B107.21



7 PIECE COMBINATION FLARE NUT WRENCH SET - 12 POINT

Product #: **J3700AT**

- › Satin finish provides corrosion resistance and a slip-resistant grip.
- › 12 point flare nut box end allows for fine indexing, helping to improve speed and access.
- › Fits 4, 6 and 12 point fasteners.
- › Flare nut box end incorporates the TorquePlus™ system.
- › Weight (lbs): 2.24



Contents	Size (in)	Point Size	Overall Length (in)
J3751T	3/8	12	5-11/16
J3752T	1/2	12	6-1/32
J3753T	7/16	12	6-7/16
J3754T	9/16	12	6-15/16
J3755T	5/8	12	7-5/8
J3756T	11/16	12	8-11/16
J3757T	3/4	12	9-3/16
J25TR03C	Tool Roll		



ASME B107.21



SATIN COMBINATION FLARE NUT WRENCHES - 6 POINT

- › Satin finish provides corrosion resistance and a slip-resistant grip.
- › Flare nut box end incorporates the TorquePlus™ system.



Product #	Size (in) (A)	Throat Depth (in) (B)	Outside Head Width (in) (C)	Head Thickness (in) (D)	Throat Depth (in) (B1)	Outside Head Width (in) (C1)	Head Thickness (in) (D1)	Overall Length (in)	Weight (lbs)
J3751	3/8	7/16	25/32	11/32	19/64	51/64	23/65	5-11/16	0.12
J3752	7/16	33/64	7/8	3/8	23/64	59/64	13/32	6-1/32	0.16
J3753	1/2	19/32	31/32	3/8	25/64	1-1/32	13/32	6-7/16	0.21
J3754	9/16	43/64	1-3/64	7/16	26/64	1-11/64	15/32	6-15/16	0.34
J3755	5/8	47/64	1-3/32	7/16	33/64	1-9/64	15/32	7-5/8	0.45
J3756	11/16	51/64	1-3/16	1/2	9/16	1-13/32	17/32	8-11/16	0.45
J3757	3/4	57/64	1-7/32	1/2	9/16	1-9/16	17/32	9-3/16	0.49



ASME B107.100

SATIN COMBINATION FLARE NUT WRENCHES - 12 POINT

- › Satin finish provides corrosion resistance and a slip-resistant grip.
- › 12 point flare nut box end allows for fine indexing, helping to improve speed and access.
- › Fits 4, 6 and 12 point fasteners.
- › Flare nut box end incorporates the TorquePlus™ system.



Product #	Size (in) (A)	Throat Depth (in) (B)	Outside Head Width (in) (C)	Head Thickness (in) (D)	Throat Depth (in) (B1)	Outside Head Width (in) (C1)	Head Thickness (in) (D1)	Overall Length (in)	Weight (lbs)
J3751T	3/8	7/16	25/32	11/32	19/64	51/64	3/8	5-11/16	0.13
J3752T	1/2	33/64	7/8	3/8	23/64	29/32	13/32	6-1/32	0.18
J3753T	7/16	19/32	31/32	3/8	25/64	1-1/32	13/32	6-7/16	0.19
J3754T	9/16	43/64	1-3/64	7/16	29/64	1-3/64	15/32	6-15/16	0.25
J3755T	5/8	47/64	1-3/32	7/16	33/64	1-19/64	15/32	7-5/8	0.32
J3756T	11/16	51/64	1-3/16	1/2	9/16	1-13/32	17/32	8-11/16	0.42
J3757T	3/4	57/64	1-7/32	1/2	9/16	1-9/16	17/32	9-3/16	0.46

ASME B107.100

3 PIECE DOUBLE END FLARE NUT WRENCH SET - 6 POINT

Product #: J3760

- › Satin finish provides corrosion resistance and a slip-resistant grip.
- › Flare nut box ends incorporate the TorquePlus™ system.
- › Weight (lbs): 0.97



Contents	Size (in)	Point Size	Overall Length (in)
J3764	3/8 x 7/16	6	6-1/4
J3768	1/2 x 9/16	6	7-1/2
J3772	5/8 x 11/16	6	8-3/4
J25TR17C	Tool Roll		10

ASME B107.100

5 PIECE METRIC DOUBLE END FLARE NUT WRENCH SET - 6 POINT

Product #: J3700M

- › Satin finish provides corrosion resistance and a slip-resistant grip.
- › Flare nut box ends incorporates the TorquePlus™ system.
- › Weight (lbs): 1.25



METRIC



Contents	Size (mm)	Point Size	Overall Length (in)
J3707M	7 x 8	6	5-11/16
J3709M	9 x 11	6	6-5/16
J3710M	10 x 12	6	6-15/16
J3713M	13 x 14	6	7-9/16
J3715M	15 x 17	6	7-63/64
J25TR06C	Tool Roll		

ASME B107.100

3 PIECE DOUBLE END FLARE NUT WRENCH SET - 12 POINT

Product #: J3760T

- › Satin finish provides corrosion resistance and a slip-resistant grip.
- › 12 point flare nut box end allows for fine indexing, helping to improve speed and access.
- › Fits 4, 6 and 12 point fasteners.
- › Flare nut box ends incorporate the TorquePlus™ system.
- › Weight (lbs): 0.97



Contents	Size (in)	Point Size	Overall Length (in)
J3764T	3/8 x 7/16	12	6-1/4
J3768T	1/2 x 9/16	12	7-1/2
J3772T	5/8 x 11/16	12	8-3/4
J25TR17C	Tool Roll		

ASME B107.100



5 PIECE METRIC DOUBLE END FLARE NUT WRENCH SET - 12 POINT

Product #: J3700MT

METRIC

- › Satin finish provides corrosion resistance and a slip-resistant grip.
- › 12 point flare nut box end allows for fine indexing, helping to improve speed and access.
- › Fits 4, 6 and 12 point fasteners.
- › Flare nut ends incorporate the TorquePlus™ system.
- › Weight (lbs): 1.29



Contents	Size (in)	Point Size	Overall Length (in)
J3707MT	7 x 8	12	5-11/16
J3709MT	9 x 11	12	6-5/16
J3710MT	10 x 12	12	6-15/16
J3713MT	13 x 14	12	7-9/16
J3715MT	15 x 17	12	7-63/64
J25TR06C	Tool Roll		

ASME B107.100



SATIN DOUBLE END FLARE NUT WRENCHES - 6 POINT

- › Satin finish provides corrosion resistance and a slip-resistant grip.
- › Flare nut box ends incorporate the TorquePlus™ system.



Product #	Size (in)	Mouth Width (in) (A)	Outside Head Width (in) (C)	Head Thickness (in) (D)	Mouth Width (in) (A1)	Outside Head Width (in) (C1)	Head Thickness (in) (D1)	Overall Length (in)	Weight (lbs)
J3764	3/8 x 7/16	19/64	51/64	11/32	23/64	57/64	3/8	6-1/4	0.18
J3768	1/2 x 9/16	25/64	31/32	3/8	13/32	1-3/64	7/16	7-1/2	0.27
J3772	5/8 x 11/16	33/64	1-7/64	7/16	37/64	1-13/64	31/64	8-3/4	0.38

ASME B107.100

SATIN METRIC DOUBLE END FLARE NUT WRENCHES - 6 POINT

- › Satin finish provides corrosion resistance and a slip-resistant grip.
- › Flare nut box ends incorporate the TorquePlus™ system.



Product #	Size (mm)	Mouth Width (in) (A)	Outside Head Width (in) (C)	Head Thickness (in) (D)	Mouth Width (in) (A1)	Outside Head Width (in) (C1)	Head Thickness (in) (D1)	Overall Length (in)	Weight (lbs)
J3707M	7 x 8	7/32	43/64	19/64	15/64	3/4	21/64	5-11/16	0.12
J3709M	9 x 11	9/32	13/16	23/64	11/32	29/32	25/64	6-5/16	0.17
J3710M	10 x 12	9/32	55/64	25/64	11/32	61/64	25/64	6-15/16	0.22
J3713M	13 x 14	3/8	1-1/64	25/64	7/16	1-3/32	29/64	7-9/16	0.26
J3715M	15 x 17	7/16	1-7/64	29/64	1/2	1-3/16	31/64	7-63/64	0.37
J3716M	16 x 18	1/2	1-9/64	29/64	37/64	1-15/64	33/64	8-13/16	0.39
J3719M	19 x 21	37/64	1-9/32	35/64	5/8	1-3/8	37/64	9-3/8	0.6



ASME B107.100

SATIN DOUBLE END FLARE NUT WRENCHES - 12 POINT

- › Satin finish provides corrosion resistance and a slip-resistant grip.
- › 12 point flare nut box end allows for fine indexing, helping to improve speed and access.
- › Fits 4, 6 and 12 point fasteners.
- › Flare nut box ends incorporate the TorquePlus™ system.



Product #	Size (in)	Mouth Width (in) (A)	Outside Head Width (in) (C)	Head Thickness (in) (D)	Mouth Width (in) (A1)	Outside Head Width (in) (C1)	Head Thickness (in) (D1)	Overall Length (in)	Weight (lbs)
J3764T	3/8 x 7/16	19/64	51/64	11/32	23/64	57/64	3/8	6-1/4	0.18
J3768T	1/2 x 9/16	25/64	31/32	3/8	13/32	1-1/16	7/16	7-1/2	0.27
J3772T	5/8 x 11/16	33/64	1-7/64	7/16	37/64	1-13/64	31/64	8-3/4	0.38



ASME B107.100

SATIN METRIC DOUBLE END FLARE NUT WRENCHES - 12 POINT

- › Satin finish provides corrosion resistance and a slip-resistant grip.
- › Flare nut box ends incorporate the TorquePlus™ system.
- › 12 point flare nut box end allows for fine indexing, helping to improve speed and access.
- › Fits 4, 6 and 12 point fasteners.



Product #	Size (mm)	Throat Depth (in) (B)	Outside Head Width (in) (C)	Head Thickness (in) (D)	Throat Depth (in) (B1)	Outside Head Width (in) (C1)	Head Thickness (in) (D1)	Overall Length (in)	Weight (lbs)
J3707MT	7 x 8	7/32	43/64	19/64	15/64	3/4	21/64	5-11/16	0.11
J3709MT	9 x 11	9/32	13/16	23/64	11/32	29/32	25/64	6-5/16	0.16
J3710MT	10 x 12	9/32	55/64	25/64	11/32	61/64	25/64	6-15/16	0.21
J3713MT	13 x 14	3/8	1-1/64	25/64	7/16	1-3/32	29/64	7-9/16	0.24
J3715MT	15 x 17	7/16	1-7/64	29/64	1/2	1-3/16	31/64	7-63/64	0.33
J3716MT	16 x 18	1/2	1-9/64	29/64	37/64	1-15/64	33/64	8-13/16	0.36
J3719MT	19 x 21	37/64	1-9/32	35/64	5/8	1-3/8	37/64	9-7/16	0.39



ASME B107.100



7 PIECE RATCHETING FLARE NUT WRENCH SET - 12 POINT

Product #: **J3800A**

- ▶ Black oxide finish.
- ▶ Non-reflective black oxide finish for use where non-plated products are required.
- ▶ 12 Point flare nut box end allows for fine indexing, helping to improve speed and access.
- ▶ Pivoting head allows user to place the wrench over the connected pipes to reach the fastener.
- ▶ Weight (lbs): 1.93



Contents	Size (in)	Point Size	Overall Length (in)
J3812	3/8	12	5-7/16
J3814	7/16	12	5-7/16
J3816	1/2	12	5-7/16
J3818	9/16	12	7-1/4
J3820	5/8	12	7-1/4
J3822	11/16	12	7-1/4
J3824	3/4	12	7-1/4
J25TR03C	Tool Roll		

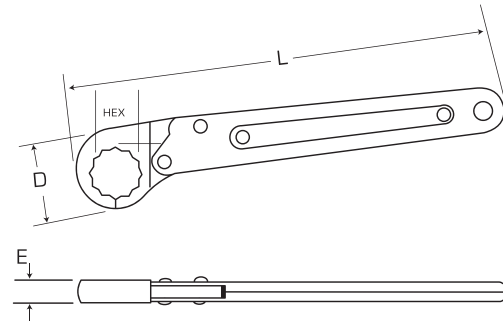
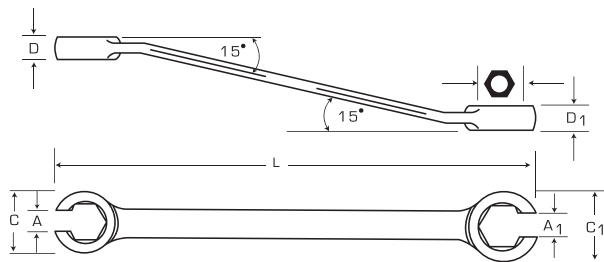

BLACK OXIDE RATCHETING FLARE NUT WRENCHES - 12 POINT

- ▶ Black oxide finish.
- ▶ Non-reflective black oxide finish for use where non-plated products are required.
- ▶ 12 Point flare nut box end allows for fine indexing, helping to improve speed and access.
- ▶ Pivoting head allows user to place the wrench over the connected pipes to reach the fastener.



Product #	Size (in)	Outside Head Width (in) (C)	Head Thickness (in) (D)	Overall Length (in)	Weight (lbs)
J3812	3/8	1	9/32	5-7/16	0.17
J3814	7/16	1	9/32	5-7/16	0.17
J3816	1/2	1	9/32	5-7/16	0.17
J3818	9/16	1-5/16	3/8	7-1/4	0.31
J3820	5/8	1-5/16	3/8	7-1/4	0.31
J3822	11/16	1-5/16	3/8	7-1/4	0.31
J3824	3/4	1-5/16	3/8	7-1/4	0.31
J3826	13/16	1-11/16	7/16	9-3/8	0.58
J3828	7/8	1-11/16	7/16	9-3/8	0.58
J3830	15/16	1-11/16	1/2	9-3/8	0.58
J3832	1	1-11/16	1/2	9-3/8	0.58

REFRIGERATION WRENCHES

- › Full polish finish provides corrosion resistance and easy to clean surfaces.
- › Designed for servicing automotive, commercial, and residential air conditioners, refrigeration units and freezers.
- › Hex openings are used for packing gland fittings, mounting bolts, clutch bolts, tubing fittings, dust cap nuts, and oil check plugs.
- › Square openings are used on male service valves, plug fittings, compressor valves, and refrigerant charging tanks.
- › Reversing switch lever allows for easy changes in turning direction which helps improve speed.



Product #	Size (in)	Size (in)	Overall Length (in)	Weight (lbs)
J1111	1/4 x 3/16 Square	9/16 x 1/2 Hex	6-3/4	0.35
J1112	3/8 x 5/16 Square	1/4 x 3/16 Hex	5-1/2	0.25



FACOM® SATIN MONKEY WRENCHES



- › Satin finish provides corrosion resistance and a slip-resistant grip.
- › Sturdy, wide-opening tools for heavy-duty work on farms and building sites.
- › Fixed jaw/handle and worm gear made from hardened steel.
- › Smooth jaw faces help prevent marring of fastener surfaces.

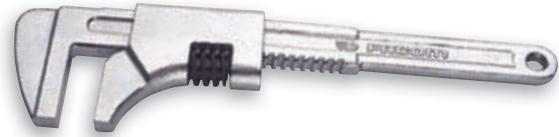

Product #	Max Opening (in)	Jaw Depth (in)	Jaw Thickness (in)	Height (in)	Overall Length (in)	Weight (lbs)
FA-105.230	2-3/8	1-25/32	25/32	19/32	9-1/16	1.15
FA-105.280	2-3/4	1-11/32	21/32	25/32	11-1/32	1.79
FA-105.375	3-1/8	1-25/32	7/8	7/8	14-23/32	3.36

PROTO-GRIP™ CAST IRON PIPE WRENCHES

- › Gripping jaw teeth and spring-loaded hook jaw; allow one-hand operation or hands free option along with a ratcheting action for job speed.
- › Standard handle lengths with wide gripping surface for increased comfort on all jobs.
- › Forged steel jaw provides outstanding strength.
- › Heel Jaw designed to work in both directions.
- › Spring hook jaw provides a ratcheting function making threaded pipe fitting efficient.
- › Hanging hole for storage.
- › Field repairable by removing the rivet pin located on the bottom side of the jaw.
- › Replacement parts available.



Product #	Max Opening (in)	Overall Length (in)	Weight (lbs)
J810PG	1-1/2	10	1.98
J814PG	2	14	3.64





ALUMINUM PIPE WRENCHES

- › Light weight aluminum for less job fatigue.
- › Standard handle lengths with wide gripping surface for increased comfort and one-hand operation.
- › Forged steel jaw provides outstanding strength.
- › Large knurl and power threads provide fast, positive jaw adjustment.
- › Graduation markings on hook jaw show approximate opening for pipe sizes.
- › Riveted jaw pin for safety.
- › Hanging hole for storage.
- › Field repairable by removing the rivet pin located on the bottom side of the jaw.
- › Replacement parts available.

Product #	Max Opening (in)	Overall Length (in)	Weight (lbs)
J810A	1-1/2	10	1.10
J812A	2	12	1.72
J814A	2	14	2.15
J818A	3-1/2	18	3.60
J824A	4	24	5.65
J836A	5	36	10.60
J848A	6	48	17.00



HEAVY-DUTY CAST IRON PIPE WRENCHES

- › Forged steel jaw provides outstanding strength.
- › Full floating hook jaw, provides instant grip, easy release.
- › Large knurl and power threads provide fast, positive jaw adjustment.

Product #	Max Opening (in)	Overall Length (in)	Weight (lbs)
J806HD	3/4	6	0.45
J808HD	1	8	0.8
J810HD	1-1/2	10	1.76
J812HD	2	12	2.66
J814HD	2	14	3.76
J818HD	3-1/2	18	5.82
J824HD	4	24	9.58
J836HD	5	36	19.32
J848HD	6	48	35.36
J860HD	8	60	41.4

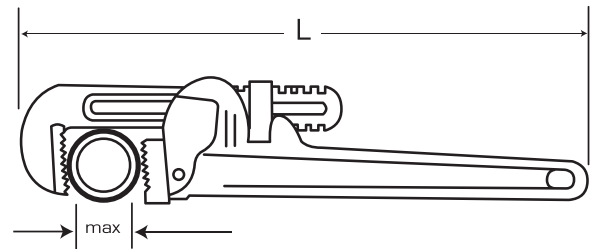

PIPE WRENCH REPLACEMENT PARTS

› Replacement parts for heavy-duty pipe wrenches.

Parts For	Handle, Heel Jaw, and Pin Assemble	Weight (lbs)	Hook Jaw	Weight (lbs)	Heel Jaw and Pin	Weight (lbs)	Knurl	Weight (lbs)	Coil and Flat Spring	Weight (lbs)
J806HD	J806H	0.33	J806B	0.11	J806C	0.02	J806D	0.03	J806E	0.01
J808HD	J808H	0.61	J808B	0.23	J808C	0.04	J808D	0.03	J808E	0.01
J810HD	J810H	1.20	J810B	0.45	J810C	0.08	J810D	0.07	J810E	0.01
J812HD	J812H	1.97	J812B	0.68	J812C	0.15	J812D	0.09	J812E	0.02
J814HD	J814H	2.79	J814B	0.97	J814C	0.15	J814D	0.11	J814E	0.03
J818HD	J818H	4.09	J818B	1.57	J818C	0.23	J818D	0.18	J818E	0.04
J824HD	J824H	7.35	J824B	2.36	J824C	0.32	J824D	0.31	J824E	0.06
J836HD	J836H	14.40	J836B	4.37	J836C	0.58	J836D	0.47	J836E	0.07
J848HD	-	-	J848B	7.31	J848C	0.72	J848D	0.68	J848E	0.11
J860HD	-	-	J860B	12.50	J860C	1.50	J860D	0.85	J860E	0.08

Parts For	Hook Jaw	Weight (lbs)	Heel Jaw	Weight (lbs)	Pin	Weight (lbs)	Spring	Weight (lbs)
J810PG	J810PGB	0.60	J810PGC	0.31	J810PGD	0.04	J810PGE	0.01
J814PG	J814PGB	0.84	J814PGC	0.29	J814PGD	0.08	J814PGE	0.01

4 PIECE INTERNAL PIPE WRENCH SET

Product #: **J140SET**

- › Ideal for removing broken threaded pipe ends, plugs, and fittings.
- › Installation and removal without thread damage.
- › Eccentric cam action engages wrench against the walls of the pipe.
- › Hex body allows for use of adjustable wrench for added torque.
- › Made from hardened steel and plated to help prevent rust.
- › Weight (lbs): 1.95

Contents	Size (in)	Overall Length (in)
J140-38	3/8	3
J140-34	3/4	3
J140-12	1/2	3
J140-1	1	3



INTERNAL PIPE WRENCHES

- › Ideal for removing broken threaded pipe ends pipe plugs and fittings.
- › Installation and removal without thread damage.
- › Eccentric cam action engages wrench against the walls of the pipe.
- › Hex body allows for use of adjustable wrench for added torque.
- › Made from hardened steel and plated to help prevent rust.

Product #	Size (in)	Overall Length	
		(in)	Weight (lbs)
J140-38	3/8	3	0.21
J140-34	3/4	3	0.49
J140-12	1/2	3	0.32
J140-1	1	3	0.85



UNIVERSAL CHAIN WRENCH

- › Fits any shape pipe.
- › Forged steel handle has deep milled teeth.
- › Chain capacity rating: 6,200 lbs.

Product #	Capacity Range	Overall Length (in)	Weight (lbs)
J801	7/8 to 4	16-1/2	2.33



UNIVERSAL CHAIN WRENCH REPAIR KIT

- › Fits any shape pipe.
- › Chain capacity rating: 6,200 lbs.

Product #	Overall Length (in)	Weight (lbs)
J801RK	6 1/5	0.73



CUSHION GRIP ADJUSTABLE WRENCHES

- › Soft cushion grip for additional comfort.
- › Extra wide jaw capacity.
- › Square jaw opening provides strength and tight fit.

Product #	Max Opening (in)	Overall Length (in)	Weight (lbs)
J704G	1/2	4	0.13
J706G	15/16	6	0.25
J708G	1-1/8	8	0.59
J710G	1-5/16	10	0.8
J712G	1-1/2	12	1.61



ASME B107.100

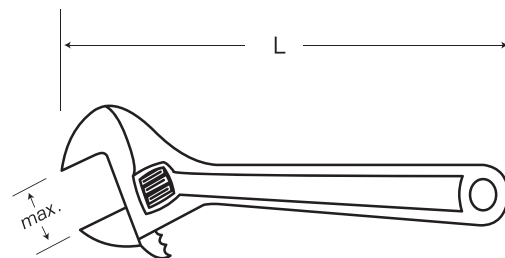

SATIN ADJUSTABLE WRENCHES

- › Satin finish provides corrosion resistance and a slip-resistant grip.
- › Extra wide jaw capacity.
- › Square jaw opening provides greater strength and better fit.
- › Rugged I-beam style handle and reinforced stress areas; radius corner design.

Product #	Max Opening (in)	Overall Length (in)	Weight (lbs)
J704	1/2	4	0.17
J706	15/16	6	0.28
J708	1-1/8	8	0.58
J710	1-5/16	10	0.9
J712	1-1/2	12	1.58
J715	1-11/16	15	3
J718	2-1/16	18	4.26
J724	2-7/16	24	6.41



AS4984

ASME B107.100

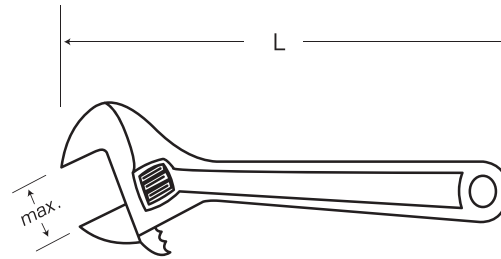

TUBING CUTTING AND FLARING SET

Product #: **J349**

- › Cuts tubing from 1/8" through 1-1/8" O.D. and puts 45° flare on tubing 3/16" through 5/8".
- › Weight (lbs): 4.40



Contents	Description
J350	Tubing Cutter
J351V	Flaring Block
J351Y	Flaring Yoke
J4029	Steel Storage Box



TUBING CUTTER

- › Cuts metal tubing from 1/8" through 1-1/8" O.D. quickly and cleanly.
- › Features heat-treated alloy steel cutting blade, special rollers, and heavy-duty screw mounted in durable steel frame.
- › Large screw-knob and retractable tubing reamer.



Product #	Diameter Dial	Weight (lbs)
J350	350c	0.82

TUBING FLARING TOOL

- › A complete flaring tool for tubing 3/16" through 5/8" O.D.
- › Includes multiple hole 45° V-block and flaring yoke with hardened, polished, ball-bearing mounted cone.
- › Ideal for use on copper tubing; not recommended for use on steel applications.



Product #	V-Blocks Only	Yoke Only	Weight (lbs)
J351	351V	351Y	0.82



7 PIECE PROTO® HOLLOW SHAFT NUT DRIVER SET

Product #: **J9200H**

- › Full hollow shaft design for maximum bolt clearance.
- › One-piece shaft design for greater strength and durability.
- › Ideal for electronics, assembly, and various industrial applications.
- › Color coded handles for easy size identification.
- › Weight (lbs): 4.22

Contents	Size (in)	Length (in) (L1)	Overall Length (in) (L)	ASME Spec.
J9206H	3/16	2-3/4	6-11/16	ASME B107.12
J9208H	1/4	2-3/4	6-11/16	ASME B107.12
J9210H	5/16	2-3/4	6-11/16	ASME B107.12
J9211H	11/32	2-3/4	6-11/16	ASME B107.12
J9212H	3/8	2-3/4	6-11/16	ASME B107.12
J9214H	7/16	2-3/4	6-11/16	ASME B107.12
J9216H	1/2	2-3/4	6-11/16	ASME B107.12
J9200CBB	Blow-Molded Case			



11 PIECE PROTO® NUT DRIVER SET

Product #: **J9200B**

- › Precision formed, heat-treated hex openings.
- › Color coded handles for easy identification.
- › One-piece shaft design for greater strength and durability.
- › Weight (lbs): 4.22

Contents	Size (in)	Length (in) (L1)	Overall Length (in) (L)	ASME Spec.
J9206	3/16	2-3/4	6-11/16	ASME B107.12
J9207	7/32	2-3/4	6-11/16	ASME B107.12
J9208	1/4	2-3/4	6-11/16	ASME B107.12
J9209	9/32	2-3/4	6-11/16	ASME B107.12
J9210	5/16	2-3/4	6-11/16	ASME B107.12
J9211	11/32	2-3/4	6-11/16	ASME B107.12
J9212	3/8	2-3/4	6-11/16	ASME B107.12
J9214	7/16	2-3/4	7	ASME B107.12
J9216	1/2	2-3/4	7	ASME B107.12
J9218	9/16	2-3/4	7	ASME B107.12
J9220	5/8	2-3/4	7	ASME B107.12
J9200DPB	Blow-Molded Case			



7 PIECE PROTO® NUT DRIVER SET

Product #: **J9200C**

- › Precision formed, heat-treated hex openings.
- › Color coded handles for easy identification.
- › One-piece shaft design for greater strength and durability.
- › Weight (lbs): 1.77

Contents	Size (in)	Length (in) (L1)	Overall Length (in) (L)	ASME Spec.
J9206	3/16	2-3/4	6-11/16	ASME B107.12
J9207	7/32	2-3/4	6-11/16	ASME B107.12
J9208	1/4	2-3/4	6-11/16	ASME B107.12
J9209	9/32	2-3/4	6-11/16	ASME B107.12
J9210	5/16	2-3/4	6-11/16	ASME B107.12
J9211	11/32	2-3/4	6-11/16	ASME B107.12
J9212	3/8	2-3/4	6-11/16	ASME B107.12
J25TR24C	Pouch			



TRADITIONAL NUT DRIVERS

- › Full hollow shaft design for maximum bolt clearance (part numbers ending with "H").
- › One-piece shaft design for greater strength and durability.
- › Ideal for electronics, assembly, and various industrial applications.
- › Color coded handles for easy size identification.

Product #	Size (in)	Size (mm)	Length (in) (L1)	Weight (lbs)
J9206H	3/16	–	2-3/4	0.18
J9208H	1/4	–	2-3/4	0.18
J9210H	5/16	–	2-3/4	0.19
J9211H	11/32	–	2-3/4	0.22
J9212H	3/8	–	2-3/4	0.19
J9214H	7/16	–	2-3/4	0.27
J9216H	1/2	–	2-3/4	0.27
J9206	3/16	–	2-3/4	0.20
J9207	7/32	–	2-3/4	0.20
J9208	1/4	–	2-3/4	0.19
J9209	9/32	–	2-3/4	0.23
J9210	5/16	–	2-3/4	0.23
J9211	11/32	–	2-3/4	0.22
J9212	3/8	–	2-3/4	0.23
J9214	7/16	–	2-3/4	0.34
J9216	1/2	–	2-3/4	0.34
J9218	9/16	–	2-3/4	0.45
J9220	5/8	–	2-3/4	0.50
J9204M	–	4	2-7/8	0.19
J9205M	–	5	2-7/8	0.19
J92055M	–	5.5	2-7/8	0.19
J9206M	–	6	2-7/8	0.19
J9207M	–	7	2-7/8	0.22
J9208M	–	8	2-7/8	0.22
J9209M	–	9	2-7/8	0.24
J9210M	–	10	2-7/8	0.29
J9211M	–	11	2-7/8	0.36
J9212M	–	12	2-7/8	0.36
J9213M	–	13	2-7/8	0.43
J9214M	–	14	2-7/8	0.50



ASME B107.12

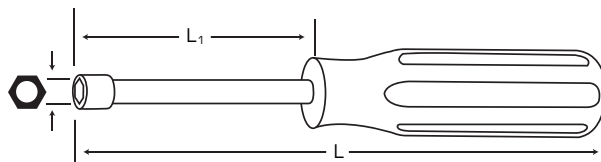

TONGUE AND GROOVE POWER-TRACK® II PLIERS

- › Precision milled undercut groove joint provides interlocking feature for powerful non-slip performance.
- › Special fastener ensures permanent assembly, yet allows for easy adjustment.
- › Angled teeth provide superior gripping power over standard right angled teeth.
- › Plastisol grips for added comfort.
- › Natural finish.



Product #	Overall Length (in) (L)	Max. Opening (in)	Jaw Length (in) (A)	Jaw Width (in) (B)	Jaw Thickness (in) (C)	Weight (lbs)
J261SG	4-5/8	15/32	7/8	13/16	3/16	0.15
J262SG	7-1/16	1-1/8	1-3/8	1-3/4	5/16	0.48
J260SG	10-3/16	2-1/8	1-15/16	2-3/4	13/32	1.00
J264SG	12	2-5/8	2-1/4	2-3/4	3/8	1.81
J265SG	16-7/8	4-1/16	3-3/8	4-1/8	17/32	3.50

 ASME B107.500

SOFT JAW - CANNON PLUG PLIERS

- › Capacity of 3/4" to 2-1/2".
- › Four position pivot design provides greater concentricity.
- › Replaceable urethane padded jaws protect work piece from marking or scratching
- › Plastisol grips for added comfort.



Product #	Overall Length (in) (L)	Max. Opening (in)	Replacement Item	Weight (lbs)
J253G	9-1/2	3/4 - 2-1/2	253GRK	0.54



HOSE CLAMP PLIERS

- › Installs and removes wire spring tension clamps.
- › Two position jaws grip full range of clamp sizes.
- › Plastisol grips for added comfort.

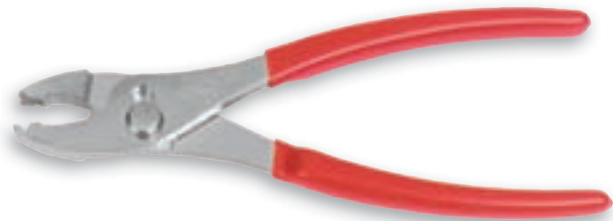

Product #	Overall Length (in) (L)	Weight (lbs)
J252G	7-3/4	0.56





OPTIMUM GRIP LOCKING PLIERS

- › Jaw configuration combining straight, curved and convex profiles.
- › Versatile tool securely gripping round, flat and large objects.
- › Multi-use for plumbers, welders and others.



Product #	Overall Length (in) (L)	Jaw Length (in) (A)	Jaw Width (in) (B)	Jaw Thickness (in) (C)	Weight (lbs)
J280XL	7-7/8	1-25/32	27/64	27/64	0.90
J281XL	9-27/32	2-5/32	1/2	1/2	1.43

LOCKING CHAIN PLIERS

- › Flexible heavy-duty, heat-treated chain which adjusts quickly around any shaped object even in awkward areas.
- › Use to remove oil filters or holding odd shapes for welding.
- › Replacement chain available - J262RC



Product #	Overall Length (in) (L)	Jaw Width (in) (B)	Weight (lbs)
J262XL	9-27/32	45/64	1.98

LOCKING CHAIN PIPE CUTTER

- › 13 Alloy steel cutting wheels to evenly cut difficult to reach thin wall pipes by hand ratcheting.
- › Locking mechanism - no squeezing, avoids risk of lateral movement and misaligned cutting.
- › Butterfly screw for easy feeding as cutting.
- › Cuts through steel, copper, aluminum, and some stainless steels.
- › Great for exhaust pipe repair and removal.
- › Use in plumbing and heating.
- › Replacement chain available - J263RC



Product #	Overall Length (in) (L)	Jaw Width (in) (B)	Weight (lbs)
J263XL	9-27/32	1-3/32	1.76

LOCKING CHAIN PIPE CUTTER PLUS

- › 15 Alloy steel cutting wheels to evenly cut difficult to reach piping up to 1/4 / 6 mm wall thickness by hand ratcheting.
- › Locking mechanism- no squeezing, avoids risk of lateral movement and misaligned cutting.
- › Cuts through galvanized steel, some stainless steels, copper, PVC, and aluminum.
- › Problem solving and time saving, ideal for plumbing, heating, joinery, and general maintenance.
- › Replacement chain available - J264RC



Product #	Overall Length (in) (L)	Jaw Width (in) (B)	Weight (lbs)
J264XL	11-9/11	1-11/64	2.76

TORQUE MULTIPLIER SQUARE DRIVE REPLACEMENT KITS

- Proto® torque multipliers provide overload protection with replaceable output square drives that are designed to twist off at 3%-10% over maximum output capacity.



Product #	Drive Size (in)	Torque Multiplier #	Weight (lbs)
J6212RD	3/4	J6212	0.20
J6222RD	1	J6222 or J6234	0.53
J6232RD	1	J6232	0.56
J6242RD	1-1/4	J6242	1.55
J6252RD	1-1/2	J6252	1.72



RATCHET HEAD REPAIR KITS - TORQUE WRENCH

- 1/4" to 1" ratchet wheels made from alloy steel for uncompromising strength and durability.
- Field repair your torque wrench ratchet head easily with the corresponding repair kit.



Product #	Drive Size (in)	Torque Wrench #	Weight (lbs)
J6062RK	1/4	J6062C, J6062CX, J6062CXCERT	0.06
J6064RK	3/8	J6064C, J6064CX, J6064CXCERT	0.07
J6006RK	3/8	J6006C, J6006CX, J6006CXCERT, J6006MC, J6006NMC, J6012C, J6066C, J6066CX, J6066CXCERT	0.18
J6014RK	1/2	J6014C, J6014CX, J6014CXCERT, J6014MC, J6014NMC, J6016C, J6016CX, J6016CXCERT, J6016MC, J6016NMC, J6068C, J6072C, J6072CX, J6072CXCERT	0.37
J6008RK	1/2	J6008C, J6008CX, J6008CXCERT	0.19
J6018RK	3/4	J6018AB, J6018CX, J6018CXCERT, J6020AB, J6020CX, J6020CXCERT, J6020NM	1.36
J6022RK	1	J6022B	1.51



3/4" DRIVE HEX BIT REPAIR KITS

Product #	Drive Size (in)	Hex Bit #	Weight (lbs)
J075901RK	3/4	J075901	0.94
J075903/4RK	3/4	J075903/4	0.41
J075905/8RK	3/4	J075905/8	0.21
J075907/8RK	3/4	J075907/8	0.62
J075909/16RK	3/4	J075909/16	0.18

**CANNON PLUG PLIERS REPAIR KIT**

Product #	Weight (lbs)
J253GRK	0.01

**UNIVERSAL CHAIN WRENCH REPAIR KIT**

- › Fits any shape pipe.
- › Chain capacity rating: 6,200 lbs

Product #	Weight (lbs)
J801RK	0.73



PIPE WRENCH REPLACEMENT PARTS

- › Replacement parts for heavy-duty pipe wrenches.

Parts For	Handle, Heel Jaw, and Pin Assemble	Weight (lbs)	Hook Jaw	Weight (lbs)	Heel Jaw and Pin	Weight (lbs)	Knurl	Weight (lbs)	Coil and Flat Spring	Weight (lbs)
J806HD	J806H	0.33	J806B	0.11	J806C	0.02	J806D	0.03	J806E	0.01
J808HD	J808H	0.61	J808B	0.23	J808C	0.04	J808D	0.03	J808E	0.01
J810HD	J810H	1.20	J810B	0.45	J810C	0.08	J810D	0.07	J810E	0.01
J812HD	J812H	1.97	J812B	0.68	J812C	0.15	J812D	0.09	J812E	0.02
J814HD	J814H	2.79	J814B	0.97	J814C	0.15	J814D	0.11	J814E	0.03
J818HD	J818H	4.09	J818B	1.57	J818C	0.23	J818D	0.18	J818E	0.04
J824HD	J824H	7.35	J824B	2.36	J824C	0.32	J824D	0.31	J824E	0.06
J836HD	J836H	14.40	J836B	4.37	J836C	0.58	J836D	0.47	J836E	0.07
J848HD	–	–	J848B	7.31	J848C	0.72	J848D	0.68	J848E	0.11
J860HD	–	–	J860B	12.50	J860C	1.50	J860D	0.85	J860E	0.08

Parts For	Hook Jaw	Weight (lbs)	Heel Jaw	Weight (lbs)	Pin	Weight (lbs)	Spring	Weight (lbs)
J810PG	J810PGB	0.60	J810PGC	0.31	J810PGD	0.04	J810PGE	0.01
J814PG	J814PGB	0.84	J814PGC	0.29	J814PGD	0.08	J814PGE	0.01

COMPRESSION GAUGE PARTS

Product #	Overall Length (in)	Use With	Weight (lbs)
JCT61	3-1/2	JCT21, JCTR10	0.39
JCT21RK	7-3/16	JCT21	0.29
JCTR10-7A	7/16	JCTR10	0.01
JCTR10RK	22-5/16	JCTR10	0.80
JCTR20-4C	2-5/16	JCTR20	0.35
JCTR20RK	9-1/2	JCTR20	0.48

