

X 1:1

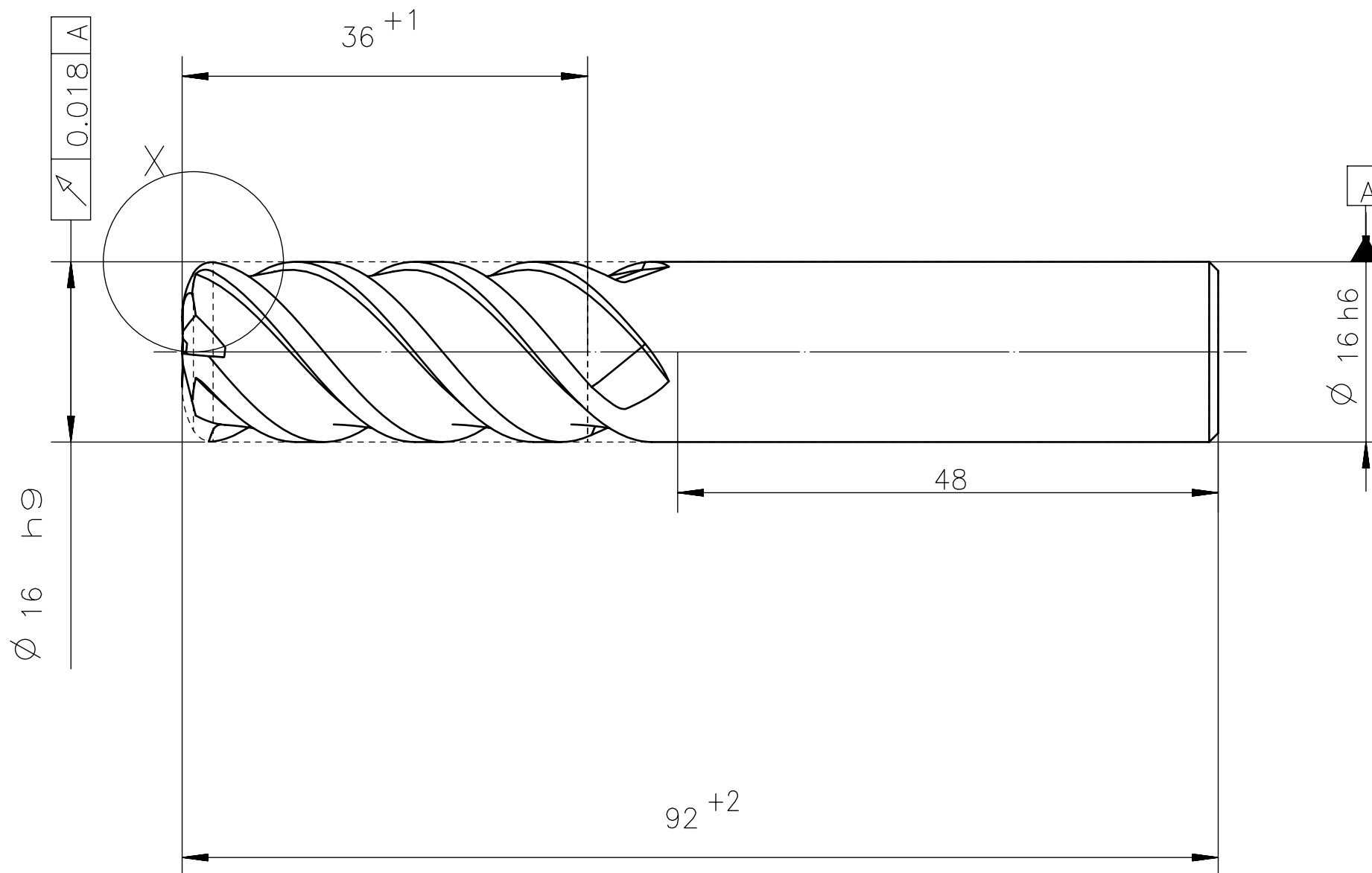

no center cut

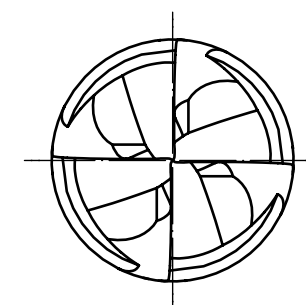

Characteristics:	
Number of teeth	4
Cutting direction	right
Spiral direction	right
Spiral angle	50
Type of face	no center cut
Type of shank	DIN 6535 HA

Qty.	Description	Det.	Dwg. No.	Material	
Proprietary Information DIN ISO 16016:2002-5 We reserve all Rights to this drawing including for the purpose of issuing patents and registration of petty patents. Without our written consent this drawing may not be copied, whole or partially, and may not be misused by the recipient as well as third parties. Any infraction will result in compensation for occurred damages and could lead to legal action by the author.				Scale: 2:1 Format: A3	
				Material: A1007 Surface: TAX	
		Date	Name	Description: Protostar Flash N50 16 x 36	
	Drawn	15.01.16	PROTOTYP		
	Checked				
				Drawing-No.:	
				H3094718-5082460	D10
Rev.	Revision	Date	Name	Cust. No.:	Ord.-Code: H3094718-16