

X

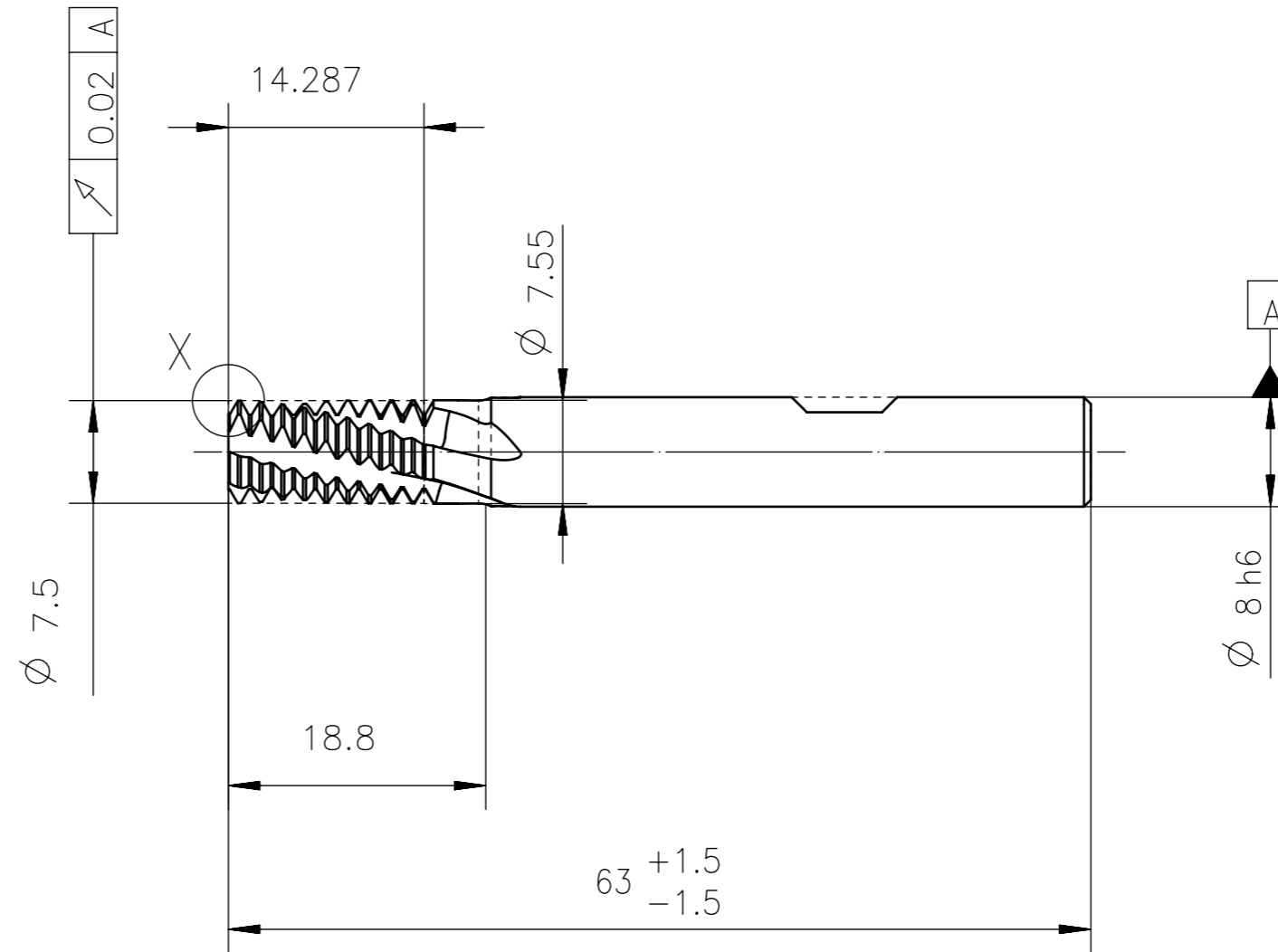

without end teeth

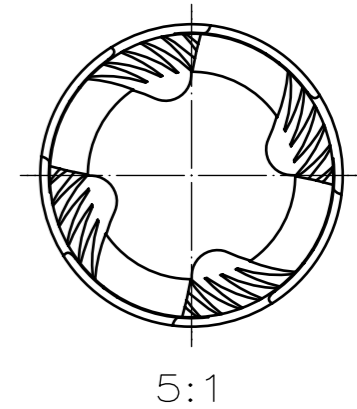

Characteristics:	
Number of teeth	4
Cutting direction	right
Spiral direction	right
Spiral angle	20
Type of face	without end teeth
Type of shank	DIN 6535 HB

Qty.	Description	Det.	Dwg. No.	Material	
Proprietary Information DIN ISO 16016:2002-5 We reserve all Rights to this drawing including for the purpose of issuing patents and registration of petty patents. Without our written consent this drawing may not be copied, whole or partially, and may not be misused by the recipient as well as third parties. Any infraction will result in compensation for occurred damages and could lead to legal action by the author.				Scale: 2:1	Format: A3
				Grade: WJ30RC	
		Date	Name	Description: TC610 Thread milling cutter 7.5 x 14.287 / 1.588 Internal  Drawing-No.: H5239108-6580349    D10	
		Drawn	12.12.13    PROTOTYP		
		Checked			
				Ord.-Code: TC610-UNC3/8-W0-WJ30RC	
Rev.	Revision	Date	Name	Cust. No.:	