

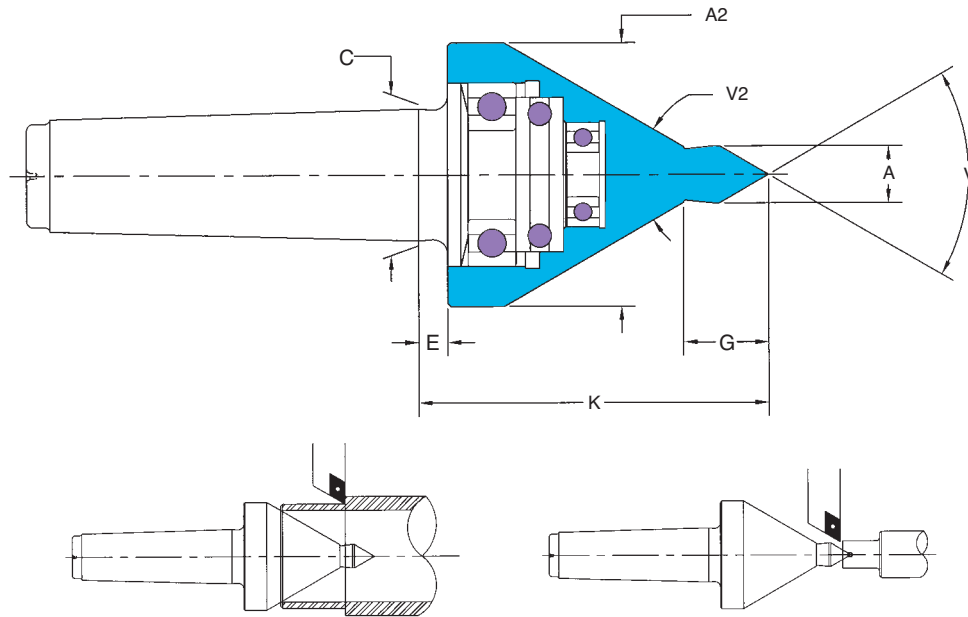

Multi-Use Live Center

- Accurate to $\pm .0001$.
- Great for manual lathe applications.
- Riten full service and repair.

The Multi-Use live center is ideal for general machine shop use. It can be used when machining thin-walled workpieces or general shaft work applications. The versatility of this center makes it a “must have” tool when your center needs change frequently.



MULTI-USE LIVE CENTER - MORSE TAPER

Model	MT	A	A2	C	E	G	K	V	V2	Max RPM	W. P. Weight
60222	2	0.50	2.25	0.700	0.25	0.75	3.19	60°	60°	5000	330
60223	3	0.50	2.25	0.938	0.25	0.75	3.19	60°	60°	5000	330
60263	3	0.63	2.63	0.938	0.25	0.94	3.75	60°	60°	4000	685
60264	4	0.63	2.63	1.231	0.39	0.94	3.89	60°	60°	4000	685
60354	4	0.76	3.50	1.231	0.38	1.13	4.63	60°	60°	3500	1165
60355	5	0.76	3.50	1.748	0.38	1.13	4.63	60°	60°	3500	1165