

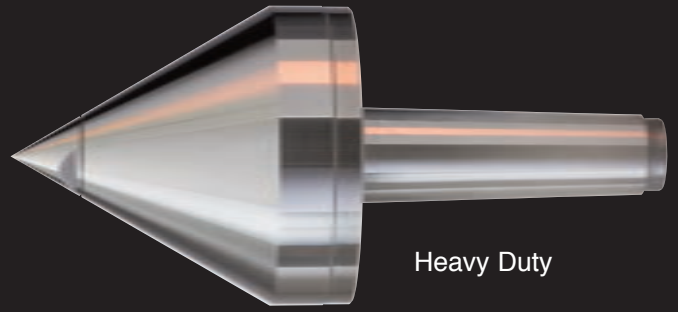

Heavy Duty & Standard Pipe Nose Live Centers

■ For use with pipe, tubing and thin walled piece parts.

Designed for use in machining pipe, tubing and other thin wall workpieces. One center fits a wide range of sizes. For the best support and chatter-free parts, choose a center where the part will seat as close to the large diameter as possible.



Heavy Duty

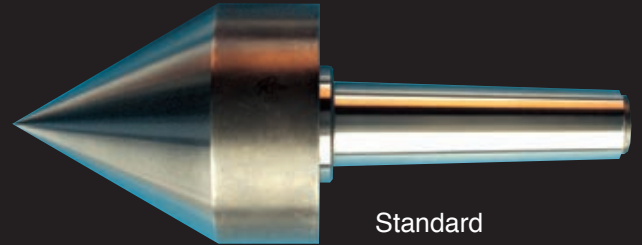

Standard

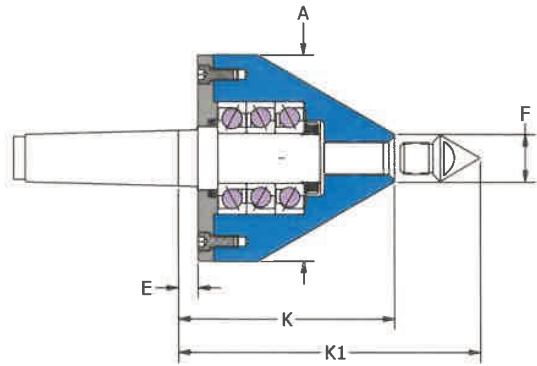

Accuracy guaranteed to $\pm .0001$

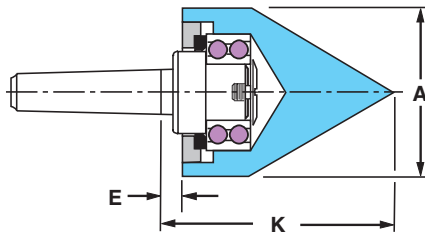

Accuracy guaranteed to $\pm .00025$

HEAVY DUTY - MORSE TAPER

Model	MT	A	F	E	K	K1	Max RPM	W. P. Weight	Point Part No.
65202*	2	2.50	-	0.26	-	3.76	8500	1350	-
65203*	3	2.50	-	0.38	-	3.88	8500	1350	-
65303	3	3.50	1.00	0.27	3.77	4.64	7800	2700	96501
65304	4	3.50	1.00	0.26	3.76	4.63	7800	2700	96501
65404	4	4.50	1.00	0.62	5.37	6.25	6000	4000	96501
65405	5	4.50	1.00	0.62	5.37	6.25	6000	4000	96501
65505	5	5.50	1.50	0.63	5.56	6.86	4000	7000	96515
65506	6	5.50	1.50	0.63	5.56	6.86	4000	7000	96515
65605	5	6.50	1.50	0.62	6.81	8.12	2600	10,000	96515
65606	6	6.50	1.50	0.62	6.81	8.12	2600	10,000	96515
65705	5	7.50	2.00	0.62	7.25	8.98	1900	15,000	96502
65706	6	7.50	2.00	0.62	7.25	8.98	1900	15,000	96502
65707	7	7.50	2.00	0.62	7.25	8.98	1900	15,000	96502

* Solid point in pipe nose design.

STANDARD - MORSE TAPER

Model	Taper	A	E	K	W. P. Weight
65252	2	2.50	0.31	3.76	260
65253	3	2.50	0.31	3.76	260
65254	4	2.50	0.31	3.76	260
65353	3	3.50	0.44	4.91	1500
65354	4	3.50	0.44	4.91	1500
65355	5	3.50	0.44	4.91	1500
65453	3	4.50	0.44	4.88	1500
65454	4	4.50	0.44	4.88	1500
65455	5	4.50	0.44	4.88	1500
65555	5	5.50	0.38	6.33	4500
65556	6	5.50	0.38	6.33	4500