

ROYAL COMBO CNC BAR PULLERS

Automate Any CNC Lathe

□ The Royal Combo CNC Bar Puller is both a bar puller and a cut-off tool in one unit. Benefits of this design include:

- Saving a turret station.
- **Reduced cycle time** because the turret does not need to index between the cut-off and pulling operations.

- Very easy to setup and use.
- Unit can pull round, square, and hex stock.
- Compact design enables it to be used on most CNC lathes.
- Each Combo Bar Puller includes one set of standard jaws and one blank spindle bushing. Order cut-off insert and holder separately.

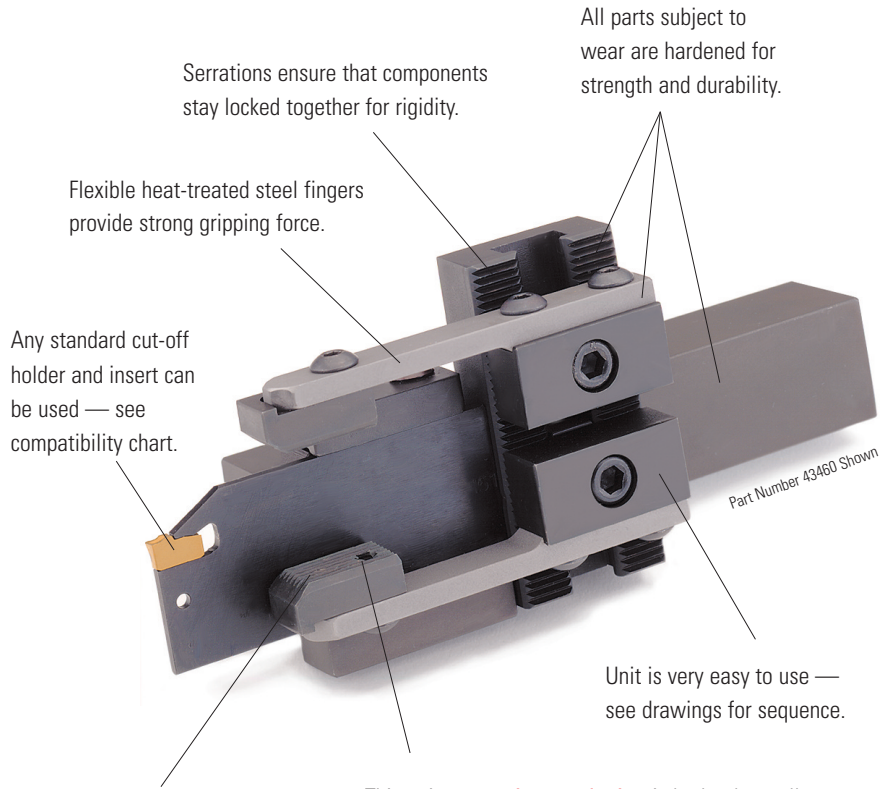

Any standard cut-off holder and insert can be used — see compatibility chart.

Serrated jaws provide positive grip. Smooth jaws are available for softer materials.

This unique **two-in-one design** is both a bar puller and a cut-off tool. Advantages include saving a turret station and reducing cycle time.

Here's how it works:

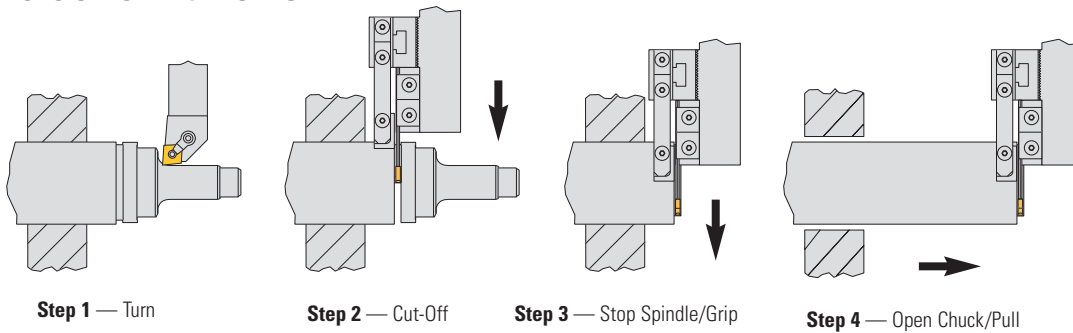

Check out the Royal Bar Puller Video
at www.barpullers.com

ROYAL COMBO CNC BAR PULLERS

Automate Any CNC Lathe

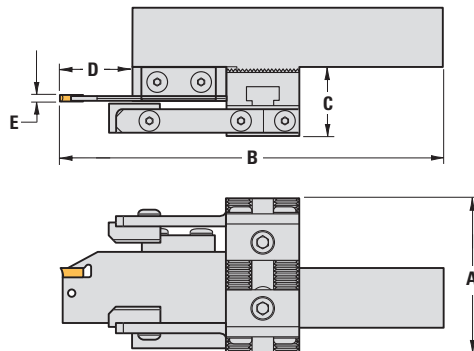
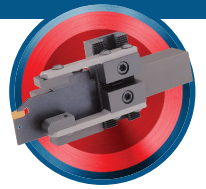

Please note dimension D (maximum depth of cut). If a greater depth of cut is required, we suggest using a separate cut-off tool and only using the bar puller for the pulling operation.

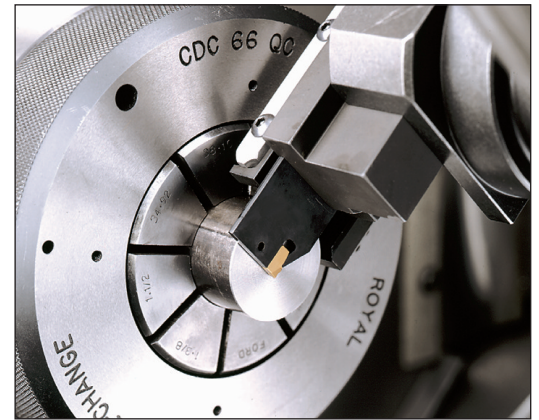

Cycle times are reduced because the turret does not need to index between cut-off and pulling operations.

Part Number 43460 Shown.

Royal Combo CNC Bar Pullers

SHANK SIZE	GRIPPING RANGE	A	B	C	MAX DEPTH OF CUT D ¹	E	PART NUMBER RIGHT HAND ² MODEL	PRICE ³
1/2" SQ	1/8" - 1 5/8"	2 1/8"	4 11/16"	1 3/16"	7/8"	0.125"	43452	\$972
3/4" SQ	1/8" - 2 1/4"	2 5/8"	4 3/4"	1 3/16"	7/8"	0.125"	43456	998
1" SQ	1/8" - 2 1/4"	2 5/8"	6 3/8"	1 3/16"	1 1/4"	0.125"	43460	1,013
1" SQ	1/8" - 3"	3 5/8"	6 3/8"	1 3/16"	1 1/4"	0.125"	43464	1,048
1" SQ	1/8" - 4"	3 5/8"	6 3/8"	1 3/16"	1 1/4"	0.125"	43468	1,191

- Cut-off holder and insert can be purchased separately from Royal Products or through your tooling supplier.
- Bar puller accepts many popular brands of holders and inserts (see chart).
- Cut-off holders not purchased from Royal must be slightly modified before being used with bar puller.

Royal Combo CNC Bar Pullers (Metric)

SHANK SIZE	GRIPPING RANGE	A	B	C	MAX DEPTH OF CUT D ¹	E	PART NUMBER RIGHT HAND ² MODEL	PRICE ³
20mm	3-57mm	67mm	121mm	30mm	22mm	3mm	43615	\$1,162
25mm	3-57mm	67mm	162mm	30mm	32mm	3mm	43625	1,173
25mm	3-76mm	92mm	162mm	30mm	32mm	3mm	43635	1,222

¹Maximum depth of cut.

²Most machines require a right-hand unit. If you need a left hand unit please contact one of our engineers at 1-800-645-4174.

³Includes bar puller, one set of standard jaws and one blank spindle bushing. Order insert holder and insert separately.

Replacement Parts — Combo Model

DESCRIPTION	PART NUMBER	PRICE/SET
Spring Finger Set	43505	\$93
Serrated Jaw Set	43500	134
Smooth Jaw Set	43502	164

Holder with Insert

BAR PULLER SHANK SIZE	PART NUMBER	PRICE*
1/2" or 3/4"	43520	\$181
1"	43522	197



*Includes one modified holder, one neutral cut-off insert, and one installation/removal tool. Royal supplies Kennametal insert GSP125N.

Compatibility Chart

BRAND	1/2", 3/4" AND 20mm SHANK	1" AND 25mm SHANK
Carbology	150.10-20-3	150.10-25-3
Iscar	SGFH26-3	SGFH32-3
Kennametal	DSB4-340-105	DSB5-340-110
Manchester	340-105	340-110
Sandvik	151.2-21-30	151.2-25-30
Valenite	VH101 26 3	VH101 32 3