

Mechanical Bottle Screw Jacks *Owner's Manual*



WARNING:

Important: read these instructions and all warnings prior to using this equipment. Understand all operating procedures, safety warnings and maintenance requirements. Failure to do so could cause an accident resulting in serious or fatal injury and/or personal property damage.

⚠️ WARNING!

- Read this entire owner's manual before using this product
- Always inspect the jack before using, replace if damaged or malfunctioning. Do not remove any of the labels from the jack
- Always ensure the jack is used on a hard flat and level surface
- Never lift any load over the rated capacity
- Always centre jack under load
- Never allow load to tilt on the jack as the jack may kick out causing injury to the operator and / or cause the load to fall
- When using more than one jack to lift a load, each jack must have the same lifting capacity of the entire load being lifted
- Never force the lifting screw past its safety stop, as the screw may come out of the jack and result in personal injury and property damage
- Always keep the screw lubricated for ease of operation and prevent against rust

⚠️ OPERATION

1. Select the appropriate lifting capacity mechanical bottle screw jack
2. Place the jack on a hard flat and level surface beneath the load that is to be lifted
3. Use hand to turn the lifting screw (counter-clockwise) out until the adjustable floating head support makes contact with the surface to be lifted
4. Insert steel handle-turning bar (not supplied - optional) in hole under lifting support
5. Rotate steel handle bar counter-clockwise to raise the lifting support until the desired height is reached

Mechanical Bottle Screw Jacks

Prod. No.	Mod. No.	Capacity (tons)	Bar Hole Size	Min Height	Lifting Height	Max Height	Net Weight
030173	SASJ-05	5	9/16" / 14.28 mm	9.45" / 240.0 mm	3.94" / 100.0 mm	13.39" / 340.0 mm	9.25 lb / 4.2 kg
030175	SASJ-10	10	11/16" / 17.46 mm	11-1/2" / 292.0 mm	6.3" / 160.0 mm	17.83" / 453.0 mm	15.64 lb / 7.1 kg
030178	SASJ-15	15	13/16" / 20.63 mm	13.86" / 352.0 mm	7.48" / 190.0 mm	21.38" / 543.0 mm	23.13 lb / 10.5 kg
030182	SASJ-20	20	1" / 25.40 mm	15.83" / 402.0 mm	9.06" / 230.0 mm	24.88" / 632.0 mm	34.36 lb / 15.6 kg
030186	SASJ-25	25	1" / 25.40 mm	16.61" / 422.0 mm	9.69" / 246.0 mm	26.34" / 669.0 mm	40.31 lb / 18.3 kg

Handle-Turning Bar for Mechanical Bottle Screw Jack - Sold Separately

Prod. No.	Mod. No.	Size	Net Weight	Fits Prod. No.	Fits Mod. No.
030174	SASJH-05	1/2" / 12.70 mm x 18" / 457.2 mm	1.23 lb / 0.56 kg	030173	SASJ-05
030176	SASJH-10	5/8" / 15.88 mm x 24" / 609.6 mm	2.11 lb / 0.96 kg	030175	SASJ-10
030179	SASJH-15	3/4" / 19.05 mm x 36" / 914.4 mm	4.96 lb / 2.25 kg	030178	SASJ-15
030183	SASJH-2025	1" / 25.40 mm x 42" / 1066.8 mm	9.05 lb / 4.11 kg	030182 / 030186	SASJ-20 / SASJ-25

⚠️ WARNING!

Each screw jack is provided with a safety stop to prevent the screw from coming all the way out when the stop is reached! Do not force the screw! Never force the screw past the safety stop! Failure to comply may cause serious injury and / or damage to property and the jack!

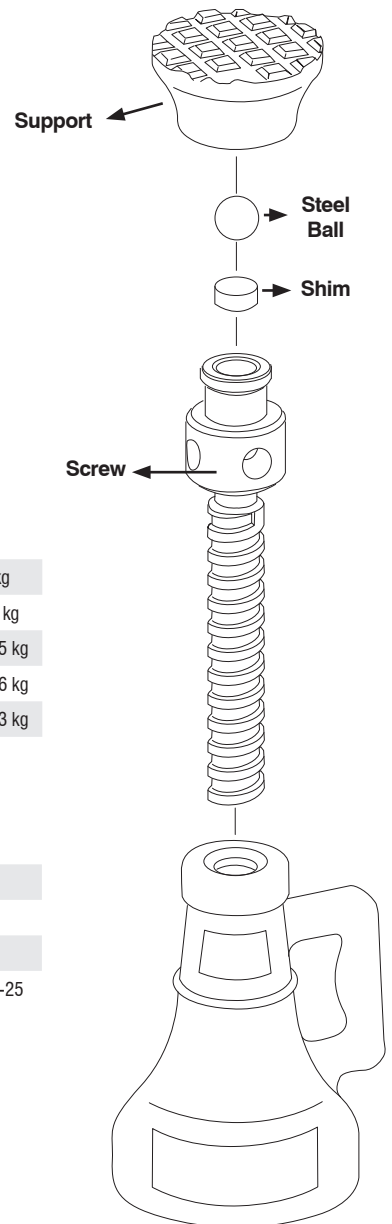

Mechanical Bottle Screw Jacks

PROD NO. 030173, 030174, 030175, 030176,
030178, 030179, 030182, 030183, 030186

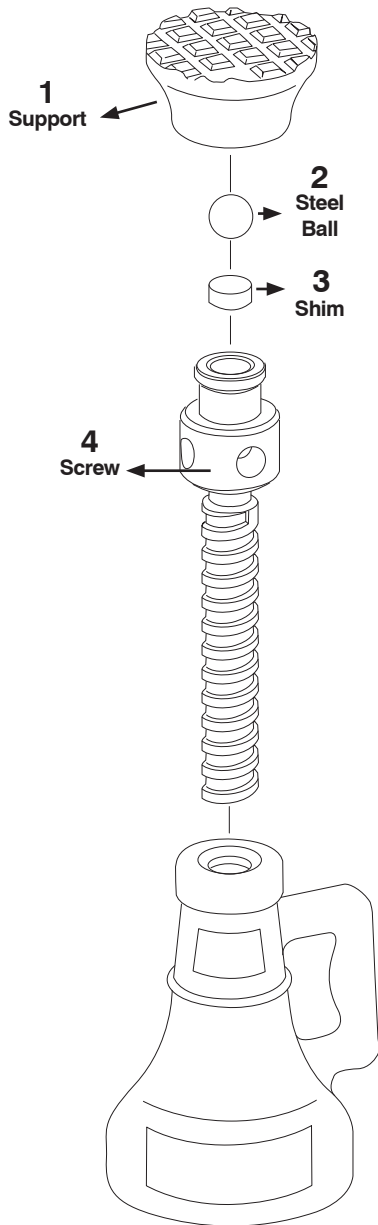

Parts Breakdown

Ref.	Part Number	Description	Req.
1	PCN-SJ05-1	Support (SASJ-05, SASJ-10, SASJ-15)	1
1	PCN-SJ20-1	Support (SASJ-20, SASJ-25)	1
2	PCN-SJ05-2	Steel ball (SASJ-05, SASJ-10, SASJ-15)	1
2	PCN-SJ20-2	Steel ball (SASJ-20, SASJ-25)	1
3	PCN-SJ05-3	Shim (SASJ-05, SASJ-10, SASJ-15)	1
3	PCN-SJ20-3	Shim (SASJ-20, SASJ-25)	1
4	PCN-SJ05-4	Main screw	1
4	PCN-SJ10-4	Main screw	1
4	PCN-SJ15-4	Main screw	1

Handle Not Shown

Prod. No.	Mod. No.	Description
030174	SASJH-05	Handle
030176	SASJH-10	Handle
030179	SASJH-15	Handle
030183	SJH-20/25	Handle

