

**STRONGARM**

LIFTING & HYDRAULIC EQUIPMENT

2 0 1 4

# Industrial Pumps and Rams





# SINGLE ACTING CYLINDERS

## CAPACITY 5-95 TON

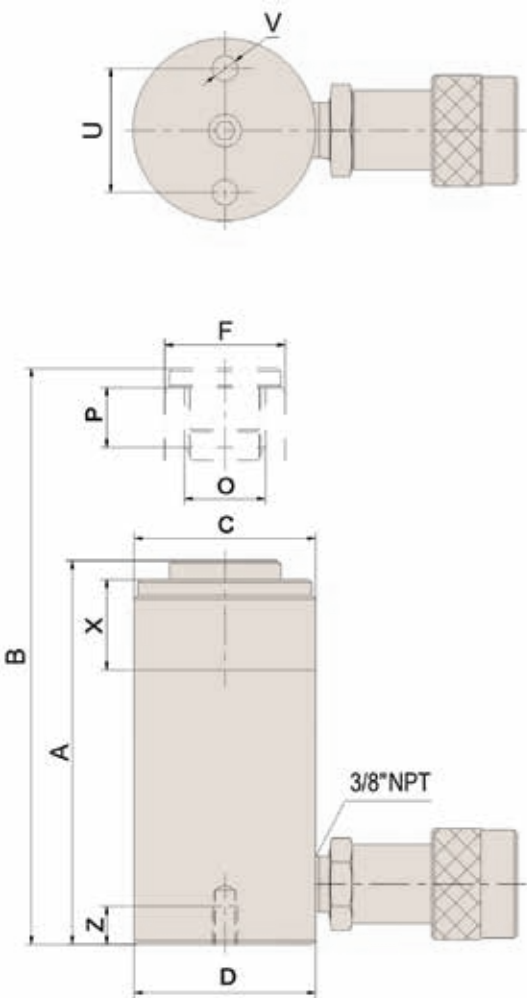

PRODUCT NO.	MODEL NO.	Cylinder Capacity @ 700 Bar (10,000 PSI)	Stroke	Cylinder Effective Area	Oil Capacity
		Metric Ton (US Ton)		IN <sup>2</sup>	
033001	<b>SACS50</b>	5 (5.5)	0.63	1.10	0.70
033005	<b>SACS55</b>	5 (5.5)	5.00	1.10	5.50
033010	<b>SACS102</b>	10 (11)	2.13	2.25	4.78
033011	<b>SACS104</b>	10 (11)	4.13	2.25	9.29
033012	<b>SACS106</b>	10 (11)	6.14	2.25	13.80
033013	<b>SACS108</b>	10 (11)	7.99	2.25	17.96
033014	<b>SACS1010</b>	10 (11)	10.12	2.25	22.73
033035	<b>SACS252</b>	25 (27.5)	1.97	5.15	10.13
033036	<b>SACS254</b>	25 (27.5)	4.02	5.15	20.66
033037	<b>SACS256</b>	25 (27.5)	6.22	5.15	32.00
033038	<b>SACS258</b>	25 (27.5)	8.27	5.15	42.53
033039	<b>SACS2510</b>	25 (27.5)	10.28	5.15	52.86
033050	<b>SACS506</b>	50 (55)	6.26	10.99	68.77
033060	<b>SACS1006</b>	95 (104.7)	6.61	20.62	136.30

- Complies with ASME B-30.1
- High strength alloy steel for safety and durability
- Inside cylinder treated to enhance durability
- Features collar threads, plunger threads and base mounting holes for optional fixture attachment.
- Heavy duty plunger spring return
- High quality 3/8"-18 NPT quick coupling
- Baked enamel finish for increased corrosion resistance





# SINGLE ACTING CYLINDERS

## CAPACITY 5-95 TON



Collapsed Height	Extended Height	Collar Thread	Collar Thread Length	Outside Diameter	Piston Rod Diameter	Piston Internal Thread	Piston Thread Length	Base Fixturing Holes			Product Weight
								BOLT CIRCLE U	THREAD V	THREAD DEPTH Z	
A	B	C	X	D	F	O	P	IN	IN	IN	lbs / kg
1.65	2.28	-	-	2.32 x 1.65	0.98	-	-	1.10	0.22	-	1.8 / 0.8
8.46	13.46	1-1/2 - 16	1.10	1.50	0.98	3/4 - 16UNF	0.63	0.98	1/4 - 20UNC	0.55	3.7 / 1.7
4.76	6.89	2-1/4 - 14	1.02	2.25	1.50	1 - 8UNC	0.75	1.54	5/16 - 18UNC	0.47	3.7 / 1.7
6.73	10.87	2-1/4 - 14	1.02	2.25	1.50	1 - 8UNC	0.75	1.54	5/16 - 18UNC	0.47	6.4 / 3
9.72	15.87	2-1/4 - 14	1.02	2.25	1.50	1 - 8UNC	0.75	1.54	5/16 - 18UNC	0.47	9.0 / 4.1
11.73	19.72	2-1/4 - 14	1.02	2.25	1.50	1 - 8UNC	0.75	1.54	5/16 - 18UNC	0.47	10.8 / 4.9
13.74	23.86	2-1/4 - 14	1.02	2.25	1.50	1 - 8UNC	0.75	1.54	5/16 - 18UNC	0.47	12.3 / 5.6
6.50	8.46	3-5/16 - 12	2.13	3.39	2.24	1-1/2 - 16UN	1.02	2.28	1/2 - 13UNC	0.75	13.6 / 6.2
8.46	12.48	3-5/16 - 12	2.13	3.39	2.24	1-1/2 - 16UN	1.02	2.28	1/2 - 13UNC	0.75	17.6 / 8
10.75	16.97	3-5/16 - 12	2.13	3.39	2.24	1-1/2 - 16UN	1.02	2.28	1/2 - 13UNC	0.75	22.7 / 10.3
12.72	20.98	3-5/16 - 12	2.13	3.39	2.24	1-1/2 - 16UN	1.02	2.28	1/2 - 13UNC	0.75	26.6 / 12.1
14.72	25.00	3-5/16 - 12	2.13	3.39	2.24	1-1/2 - 16UN	1.02	2.28	1/2 - 13UNC	0.75	31.0 / 14.1
11.10	17.36	5 - 12	2.17	5.00	3.15	-	-	3.74	1/2 - 13UNC	0.75	48.8 / 22.1
14.06	20.67	6-7/8 - 12	1.73	6.97	4.13	-	-	5.47	3/4 - 10UNC	0.98	131.3 / 159.6

1. Guide ring eliminates over travel, and provides support to reduce wear from off-centre loads.
2. Heavy duty wiper ring keeps dust and debris out of cylinder body, improving performance and service life.
3. Bearing ring provides additional support to reduce wear from off-centre loads.
4. All-steel body with baked enamel finish for durability.
5. Hardened and chromed piston increases durability and reduces wear.
6. Secondary gasket and industrial seal ring assembly prevents costly leaks.
7. Standard coupler on all cylinders provided with heavy duty dust cover.
8. High strength return spring.

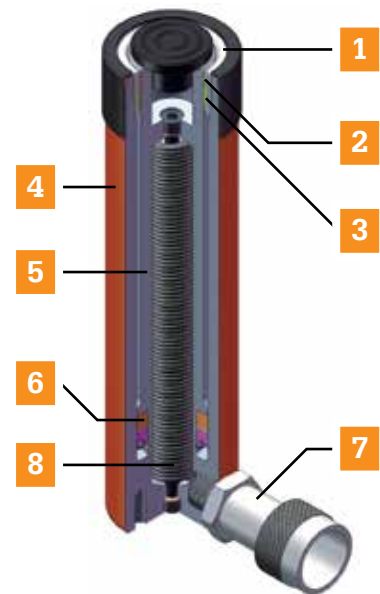



**Low Height**  
**SINGLE ACTING CYLINDERS**  
CAPACITY 5-50 TON



- For use in confined spaces
- Complies with ASME B-30.1
- High strength alloy steel for durability
- Mounting holes for fixture attachment
- Heavy duty plunger return springs
- High quality 3/8"-18NPT quick coupling
- Grooved plunger end with threaded hole for mounting tilt saddles
- Baked enamel finish for increased corrosion resistance



**Low Height**  
**SINGLE ACTING CYLINDERS**  
 CAPACITY 5-50 TON



1. Steel guide ring eliminates over travel and withstands full dead-end load, it also provides support to reduce wear from off-centre loads.
2. Hardened and chromed piston increases durability and reduces wear.
3. All-steel body with baked enamel finish for durability.
4. High strength return spring.
5. Secondary gasket and industrial seal ring assembly prevents costly leaks.
6. Standard coupler on all cylinders provided with heavy duty dust cover.

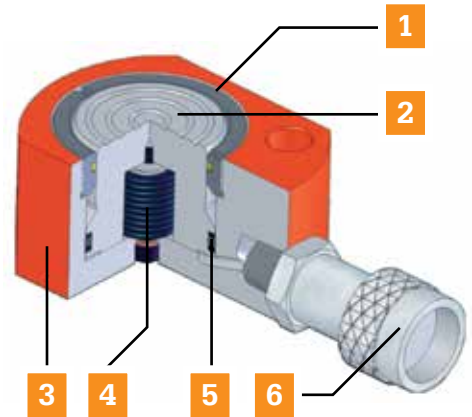

PRODUCT NO.	MODEL NO.	Cylinder Capacity @ 700 Bar (10,000 PSI)	Stroke	Cylinder Effective Area	Oil Capacity	Collapsed Height	Extended Height	Outside Diameter	Piston Rod Diameter	Top Dimensions				Product Weight
						A	B			D	F	M	L	
		Metric Ton (US Ton)	IN	IN <sup>2</sup>	IN <sup>3</sup>	IN	IN	IN	IN	IN	IN	IN	IN	lbs / kg
033061	<b>SACL50</b>	5 (5.5)	0.24	1.10	0.26	1.30	1.54	2.32 x 1.65	0.98	0.91	0.83	0.22	1.12	1.30 / 0.6
033063	<b>SACL100</b>	10 (11)	0.39	2.25	0.88	1.65	2.09	3.27 x 2.20	1.50	1.34	1.10	0.28	1.44	3.30 / 1.5
033065	<b>SACL200</b>	20 (22)	0.43	4.39	1.90	2.01	2.44	3.98 x 3.00	2.01	1.57	1.57	0.39	1.94	5.90 / 2.7
033070	<b>SACL300</b>	30 (33)	0.51	6.48	3.31	2.30	2.80	4.61 x 3.74	2.60	1.77	1.89	0.39	2.05	9.50 / 4.3
033074	<b>SACL500</b>	50 (55)	0.63	9.86	6.21	2.64	3.27	5.51 x 4.49	2.76	2.13	2.24	0.43	2.62	14.70 / 6.7

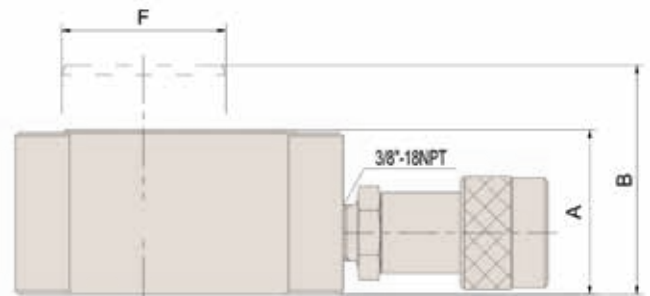
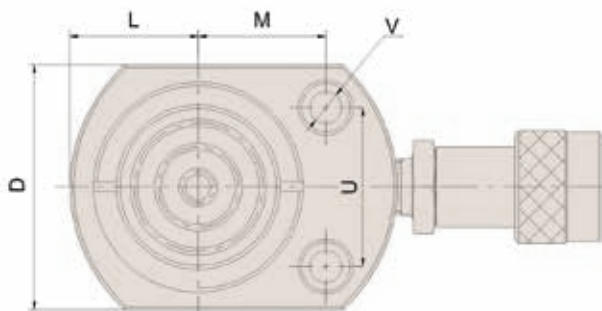



**Hollow Centre**  
**SINGLE ACTING CYLINDERS**  
 CAPACITY 20-30 TON

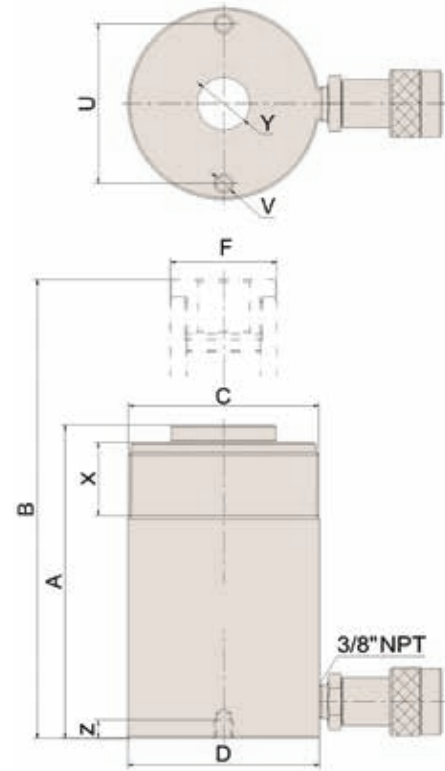

- Hollow plunger design allows for both push and pull forces
- Complies with ASME B-30.1
- High strength alloy steel for durability and added safety
- Single acting spring return
- High quality 3/8"-18NPT quick couplings
- Collar and plunger threads for fixture attachment
- Baked enamel finish for corrosion resistance

PRODUCT NO.	MODEL NO.	Cylinder Capacity @ 700 Bar (10,000 PSI)	Stroke	Cylinder Effective Area	Oil Capacity	Collapsed Height	Extended Height	Collar Thread	Collar Thread Length	Outside Diameter
						A	B	C	X	D
		Metric Ton (US Ton)	IN	IN <sup>2</sup>	IN <sup>3</sup>	IN	IN	IN	IN	IN
033076	<b>SACH202</b>	20 (22)	1.93	5.08	9.80	6.38	8.31	3-7/8 - 12	1.50	3.90
033077	<b>SACH206</b>	20 (22)	6.10	5.08	31.01	12.05	18.15	3-7/8 - 12	1.50	3.90
033078	<b>SACH302</b>	30 (33)	2.52	7.39	18.62	7.01	9.53	4-1/2 - 12	1.65	4.53
033079	<b>SACH306</b>	30 (33)	6.10	7.39	45.10	12.99	19.09	4-1/2 - 12	1.65	4.53



**Hollow Centre**  
**SINGLE ACTING CYLINDERS**  
 CAPACITY 20-30 TON



1. Steel guide ring eliminates over travel and withstands full dead-end load, it also provides support to reduce wear from off-centre loads.
2. Bearing ring provides additional support to reduce wear from off-centre loads.
3. Hardened and chromed piston increase durability and reduces wear.
4. High strength return spring.
5. All steel body with baked enamel finish for durability.
6. Industrial bearing ring provides additional support to reduce wear from off-centre loads.
7. Industrial seal ring assembly prevent costly leaks.
8. Standard coupler on all cylinders provided with heavy duty dust cover.

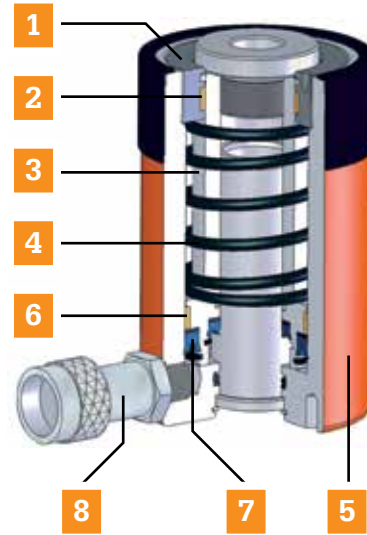

Piston Rod Diameter	Base Fixturing Holes			Center Hole Diameter	Product Weight
	BOLT CIRCLE U	THREAD V	THREAD DEPTH Z	Y	
IN	IN	IN	IN	IN	lbs / kg
2.17	3.25	3/8 - 16UNC	0.37	1.06	16.06 / 7.3
2.17	3.25	3/8 - 16UNC	0.37	1.06	29.48 / 13.4
2.56	3.63	3/8 - 16UNC	0.55	1.31	23.10 / 10.45
2.56	3.63	3/8 - 16UNC	0.55	1.31	42.46 / 19.3



# AIR/HYDRAULIC FOOT PUMPS



- Can be used with a variety of hydraulic cylinders, presses or other hydraulic equipment
- Provides up to 10,000 PSI of hydraulic pressure (0.6 - 1.0 Mpa)
- Air exhaust muffler for quiet operation
- Internal load limiting device provides overload protection
- Air input port thread 1/4"NPT, Oil output 3/8"-18NPT
- Features both air and oil filters to reduce risk of damage from environmental contaminants

PRODUCT NO.	MODEL NO.	Pressure Rating	Air Source Pressure	Usable Oil Capacity	Flow		Dimensions			Reservoir Material	Control Method	Product Weight
					No Load	Load	L	W	H			
		PSI	PSI	IN <sup>3</sup>	IN <sup>3</sup> /MIN		IN	IN	IN			lbs / kg
033125	<b>AHP002</b>	10,000	90 -145	98	49.5	7.6	10.3	5.3	7.3	Aluminum alloy	Foot pedal	19 / 9
033126	<b>AHP003</b>	10,000	90 -145	275	49.5	7.6	12.5	7	7.5	Steel	Foot pedal	28 / 13
033127	<b>AHP004</b>	10,000	90 -145	442	49.5	7.6	11	8.8	10	Steel	Foot pedal	36 / 16

## AIR/HYDRAULIC FOOT PUMP SELECTION

PRODUCT NO.	MODEL NO.	Stage	Flow (IN <sup>3</sup> )	Capacity (TONS)								
				5	10	15	25	30	50	75	100	150
				<b>Required time ( seconds ) for cylinder to lift 1 inch</b>								
033125	<b>AHP002</b>	Low Pressure	0.81	1.30	2.90	3.90	6.40	8.30	15.00	19.50		
		High Pressure	0.12	8.70	19.00	26.30	42.50	55.00	100.00	130.00		
033126	<b>AHP003</b>	Low Pressure	0.81	1.30	2.90	3.90	6.40	8.30	15.00	19.50	25.60	
		High Pressure	0.12	8.70	19.00	26.30	42.50	55.00	100.00	130.00	166.00	
033127	<b>AHP004</b>	Low Pressure	0.81	1.30	2.90	3.90	6.40	8.30	15.00	19.50	25.60	38.00
		High Pressure	0.12	8.70	19.00	26.30	42.50	55.00	100.00	130.00	166.00	252.50





# SINGLE ACTING HAND PUMPS

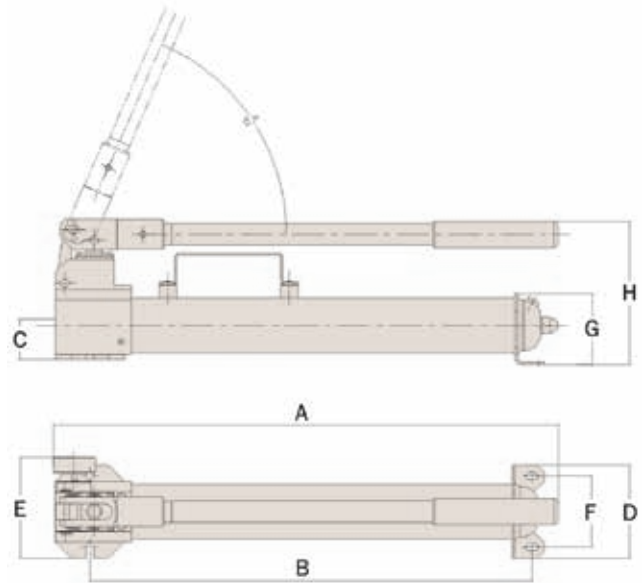

- Single acting hand pumps made of high strength alloy steel; corrosion resistant and engineered for use in extreme environments
- Internal pressure relief valve for overload protection
- Compact design for storage and transportation
- Compatible with various cylinders and tools

PRODUCT NO.	MODEL NO.	Speed	Usable Oil Volume	Pressure Rating		Oil Output Per Stroke		Handle Force	Oil Output Thread	Product Weight
				1st Stage	2nd Stage	1st Stage	2nd Stage			
			IN <sup>3</sup>	PSI	PSI	IN <sup>3</sup>	IN <sup>3</sup>	lbs	IN	lbs / kg
033101	<b>HPS55</b>	Dual	55	360	10,000	2.038	0.201	108	3/8 - 18NPT	16.06 / 4.56
033102	<b>HPS140</b>	Dual	140	360	10,000	2.038	0.201	108	3/8 - 18NPT	22.22 / 10.08

## HAND PUMP SELECTION CHART

PRODUCT NO.	MODEL NO.	Stage	Flow (IN <sup>3</sup> )	Capacity (TONS)						
				5	10	15	25	30	50	75
				Required Strokes for Cylinder to lift 1 inch						
033101	<b>HPS55</b>	1st Stage	2.038	1	2	2	3			
		2nd Stage	0.201	6	12	16	26			
033102	<b>HPS140</b>	1st Stage	2.038	1	2	2	3	4	6	8
		2nd Stage	0.201	6	12	16	26	31	55	81



**INDUSTRIAL**

# RUBBER HYDRAULIC HOSES



PRODUCT NO.	MODEL NO.	Hose Material	Internal Diameter	Working Pressure	Burst Pressure	Thread	Length
			IN	PSI	PSI	IN	FT
033130	<b>HPH8206</b>	Rubber	1/4	10,000	20,000	3/8 - NPT	6
033131	<b>HPH8210</b>	Rubber	1/4	10,000	20,000	3/8 - NPT	10
033132	<b>HPH8220</b>	Rubber	1/4	10,000	20,000	3/8 - NPT	20
033133	<b>HPH8306</b>	Rubber	3/8	10,000	20,000	3/8 - NPT	6
033134	<b>HPH8310</b>	Rubber	3/8	10,000	20,000	3/8 - NPT	10
033135	<b>HPH8320</b>	Rubber	3/8	10,000	20,000	3/8 - NPT	20

# QUICK COUPLERS

PRODUCT NO.	MODEL NO.	Max Pressure	Type	Thread	Coupler Type
		PSI		IN	
033140	<b>QC201MF</b>				Male / Female
033141	<b>QC201F</b>	10,000	High flow	3/8 - 18NPT	Female
033142	<b>QC201M</b>				Male



# HYDRAULIC VALVES

## 033165

Needle valve, manually controls the speed of cylinder, can be used as a shut-off valve for temporary load holding

## 033160

Manually operated check valve used to hold load with single or double acting cylinder, manually opened to allow oil to flow back to oil reserve when cylinder retracts.

033160



033165





**INDUSTRIAL**

# PRESSURE GAUGES

PRODUCT NO.	MODEL NO.	Pressure Range		Thread	Gauge Diameter
		MPa	PSI		
033150	<b>HPG2510</b>	0 - 100	0 - 15,000	1/4 - NPT	2.5
033151	<b>HPG4010</b>	0 - 100	0 - 15,000	1/2 - NPT	4



# GAUGE ADAPTORS

PRODUCT NO.	MODEL NO.	Female Coupler Thread	Male Coupler Thread	Gauge Thread	A	B	C	D	E	F
		IN	IN	IN	IN	IN	IN	IN	IN	IN
033152	<b>GA001</b>	3/8 - NPT	3/8 - NPT	1/2 - NPT	2.79	1.22	1/2 - NPT	3/8 - NPT	3/8 - NPT	1.25
033153	<b>GA002</b>	3/8 - NPT	3/8 - NPT	1/2 - NPT	6.1	1.37	1/2 - NPT	3/8 - NPT	3/8 - NPT	1.25
033154	<b>GA003</b>	3/8 - NPT	3/8 - NPT	1/4 - NPT	5.23	1.88	1/4 - NPT	3/8 - NPT	3/8 - NPT	1.25
033155	<b>GA004</b>	3/8 - NPT	1/4 - NPT	1/2 - NPT	4.37	1.37	1/2 - NPT	1/4 - NPT	3/8 - NPT	1.25
033156	<b>GA005</b>	3/8 - NPT	3/8 - NPT	1/4 - NPT	5.27	1.37	1/4 - NPT	3/8 - NPT	1/4 - NPT	1.25

