

Doosan Machine Tools

Lynx 220 LMS/LY/LSY, Lynx 2100 M/MS

Toolholder Program



Lynx 220 LMS/LY/LSY, Lynx 2100 M/MS

Coromant Capto® Program

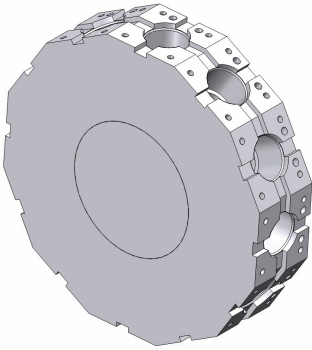

—

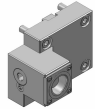

Straight clamping unit

C3	C3-TRE-BT45A	Standard
C3	C3-TLE-BT45A	Standard
C4	C4-TRE-BT45A	Standard
C4	C4-TLE-BT45A	Standard



—

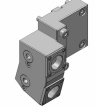

Straight clamping unit, double

C3	C3-TRE-BT45A-TT	Standard
C3	C3-TLE-BT45A-TT	Standard



—



Straight clamping unit, both sides

C3	343-830111C1228	For quotation
----	-----------------	---------------



—



Straight clamping unit, both sides

C4	C4-TRE-BT45A-DT	Standard
C4	C4-TLE-BT45A-DT	Standard



—



Right angle clamping unit, L2=65

C3	C3-TRI-BT45A	Standard
C3	C3-TLI-BT45A	Standard
C4	C4-TRI-BT45A	Standard
C4	C4-TLI-BT45A	Standard



—

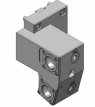

Right angle clamping unit, double

C3	C3-TRI-BT45A-TT	Standard
C3	C3-TLI-BT45A-TT	Standard



—

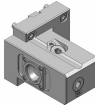

Right angle clamping unit, both sides

C3	C3-TRI-BT45A-DT	Standard
C3	C3-TLI-BT45A-DT	Standard

Lynx 220 LMS/LY/LSY, Lynx 2100 M/MS

Coromant Capto® Program

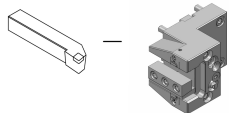

OD cutting holder, IC

20	ASH-TNE-BT45A-20HP	IC 80 bar	Standard
----	--------------------	-----------	----------

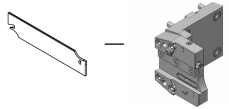

Cut-off holder, adjustable, IC

SH 26	APBR-BT45A-21-HP	IC 80 bar	Standard
SH 26	APBL-BT45A-21-HP	IC 80 bar	Standard

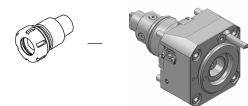

Straight drill/milling unit

C3	C3-DNE-BT45A-E	1:1	EC	Standard
C3	C3-DNE-BT45A-I	1:1	IC 80 bar	Standard

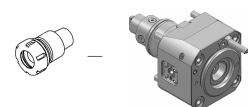

OD drill/milling unit (special offer!)

C3	343-830820N2493	1:1	EC	For quotation
C3	343-830820N2494	1:1	IC 80 bar	For quotation

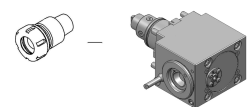

Right angle drill/milling unit

C3	C3-DNI-BT45A-E	1:1	EC	Standard
C3	C3-DNI-BT45A-I	1:1	IC 80 bar	Standard

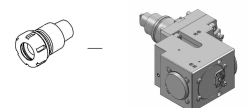

Right angle back set drill/milling unit

C3	C3-DNI-BT45A-E-SS	1:1	EC	Standard
C3	C3-DNI-BT45A-I-SS	1:1	IC 80 bar	Standard

Turning applications

Tool holder	Insert/Tool	Insert
T-Max® P	 > CNMG	
CoroTurn® 107	 > CCMT	
T-Max® P	 > DNMG	
CoroTurn® 107	 > DCMT	
CoroTurn® 107	 > VBMT	
CoroThread® 266	 > 266	
CoroTurn® SL	 > CoroTurn® 107	 > TCMT
CoroTurn® 107		
CoroTurn® 107		
Silent Tools™	 > CoroTurn® 107	 > VBMT
Drill adaptor	 > CoroDrill® 870	 > Exchangeable drill tip
	 > CoroDrill® 881	 > Indexable drilling insert
	 > EasyFix	 > Boring bars
		 > Boring bars
		 > Boring bars

Rotating applications

Tool holder	Insert/Collet/Tool	Insert
Coromant EH	 > CoroMill® 316	
	 > CoroMill® 390	 > R390 
	 > CoroMill® 490	 > 490R 
	 > CoroMill® 216	 > R216 
	 > CoroMill® 300	 > R300 
	 > CoroBore® 824	 > CXS 
	 > CoroBore® 825	 > TCMT 
CoroChuck™ 930	 > Cylindrical collet	 > CoroMill® Plura 
		 > CoroDrill® 860 
ER collet chuck	 > ER collet	 > CoroMill® Plura 
		 > CoroDrill® 860 
CoroMill® 390	 > R390	