

Okuma LB/LU 4000 EX M/MY

Toolholder Program



LB/LU 4000 EX M/MY

Coromant Capto® Program

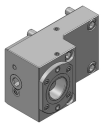
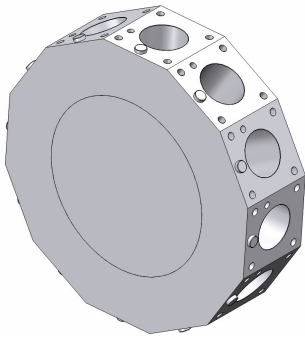

OD clamping unit

C4	343-830111C506	For quotation
C5	C5-TRE-OK60B	Standard
C5	C5-TLE-OK60B	Standard

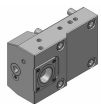

OD clamping unit, short

C4	343-830111C687	For quotation
C5	343-830111C424	For quotation

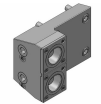

OD clamping unit, double, Y axis

C4	343-830111C549	For quotation
C5	C5-TRE-OK60B-YT	Standard
C5	C5-TLE-OK60B-YT	Standard

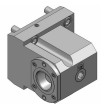

Face and ID clamping unit

C4	343-830111C548	For quotation
C5	C5-TRI-OK60B	Standard
C5	C5-TLI-OK60B	Standard

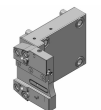

Cut-off holder, adjustable, IC

SH 32	APBR-OK60B-25-HP IC 80 bar	Standard
SH 32	APBL-OK60B-25-HP IC 80 bar	Standard

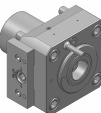

OD drill/milling unit

C4	C4-DNE-OK60B-E	1:1	EC	Standard
C4	C4-DNE-OK60B-I	1:1	IC 80 bar	Standard

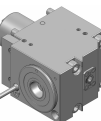

Face drill/milling unit

C4	C4-DNI-OK60B-E	1:1	EC	Standard
C4	C4-DNI-OK60B-I	1:1	IC 80 bar	Standard

Turning applications

Tool holder	Insert/Tool	Insert
T-Max® P	 > CNMG	
CoroTurn® 107	 > CCMT	
T-Max® P	 > DNMG	
CoroTurn® 107	 > DCMT	
CoroTurn® 107	 > VBMT	
CoroThread® 266	 > 266	
CoroTurn® SL	 > CoroTurn® 107	 > TCMT
CoroTurn® 107		
CoroTurn® 107		
Silent Tools™	 > CoroTurn® 107	 > VBMT
Drill adaptor	 > CoroDrill® 870	 > Exchangeable drill tip
	 > CoroDrill® 881	 > Indexable drilling insert
	 > EasyFix	 > Boring bars
		 > Boring bars
		 > Boring bars

Rotating applications

Tool holder	Insert/Collet/Tool	Insert
Coromant EH	 > CoroMill® 316	
	 > CoroMill® 390	 > R390 
	 > CoroMill® 490	 > 490R 
	 > CoroMill® 216	 > R216 
	 > CoroMill® 300	 > R300 
	 > CoroBore® 824	 > CXS 
	 > CoroBore® 825	 > TCMT 
CoroChuck™ 930	 > Cylindrical collet	 > CoroMill® Plura 
		 > CoroDrill® 860 
ER collet chuck	 > ER collet	 > CoroMill® Plura 
		 > CoroDrill® 860 
CoroMill® 390	 > R390	