

# Ordering information

Silent Tools™ Plus

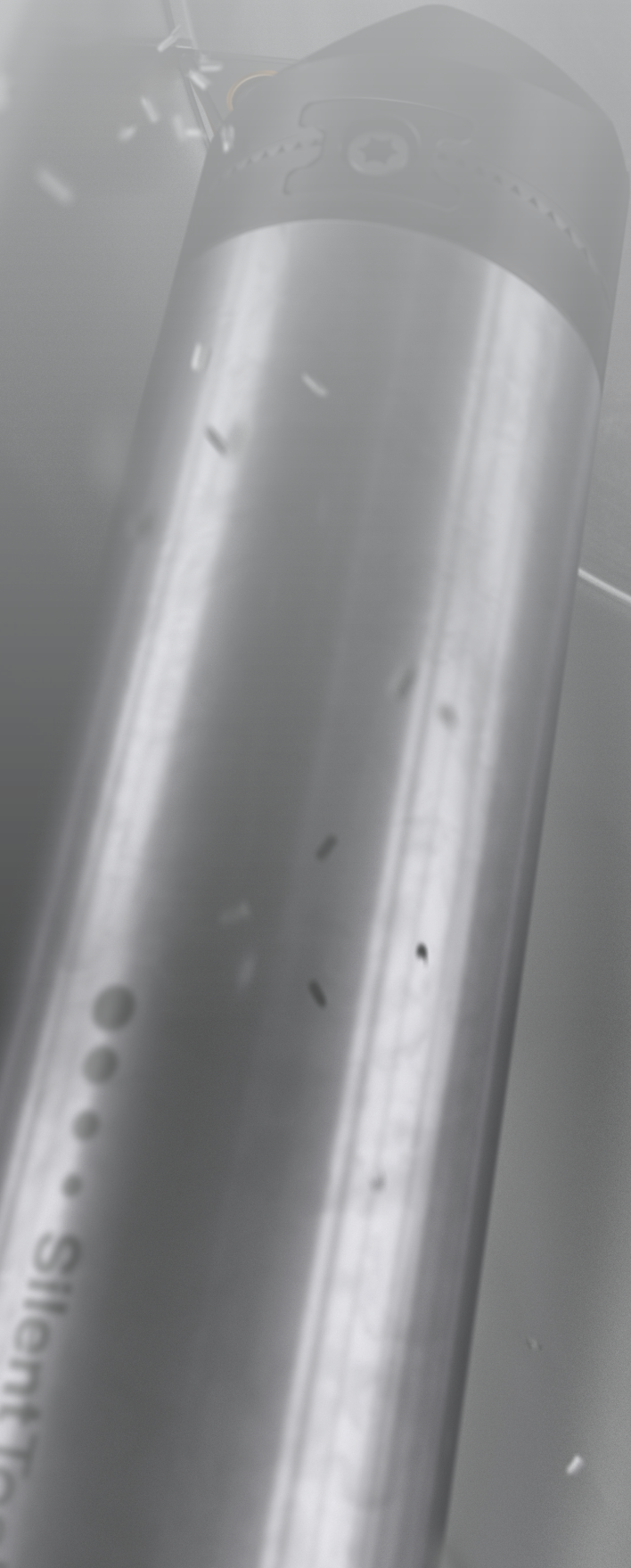

# Silent Tools™ Plus



## Connected turning solution

The sensor-equipped Silent Tools™ Plus damped adaptors increase process security in internal turning with long overhang. The solution gives you access to information about what's happening inside your component, making process improvements possible.

The product kit includes necessary cables, batteries, electronic unit, charger and wall charging adaptor. The Windows 10 tablet needed to access the Silent Tools Plus dashboard is not included.

Before starting to use the solution, you will need to activate your license. Documentation of how to activate your license and get started is delivered together with the tool. The same instruction can also be found on the Sandvik Coromant web.

Silent Tools Plus is available in selected markets within the European union and North America.

For more information, visit [www.sandvik.coromant.com/silenttoolsplus](http://www.sandvik.coromant.com/silenttoolsplus)



- 1 European & Canadian version
- 2 US version
- 3 Wedge Lock cutting heads
- 4 Engineered solutions

# Silent Tools™ Plus

European version

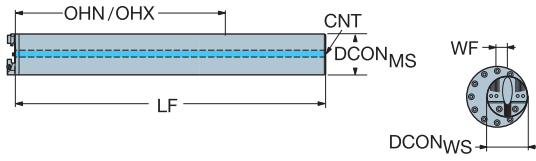

●●● SilentTools®

							Dimensions, mm						
CZC <sub>MS</sub>	CZC <sub>WS</sub>	OHN	OHX	CNSC	CXSC	Ordering code	DCON <sub>MS</sub>	DCON <sub>WS</sub>	LF	WF	CNT	BAR	KG
60	40	600	600	1	1	TA60D-CY60B810W4RB	60	40	810	10	G1/8	150	15
80	40	800	800	1	1	TA60D-CY80B1090W4RB	80	40	1090	20	G1/8	150	40
100	40	1000	1000	1	1	TA60D-CY100B1410W4RB	100	40	1410	30	G1/8	150	80

The ordering codes above are kits containing all the hardware you will need, but when ordering a Silent Tools Plus adaptor kit, you also need to order a service pack.

Service pack ordering code:  
 ST P VIBRATION 001 (Yearly license)  
 ST P VIBRATION 101 (One time fee)

## Spare parts

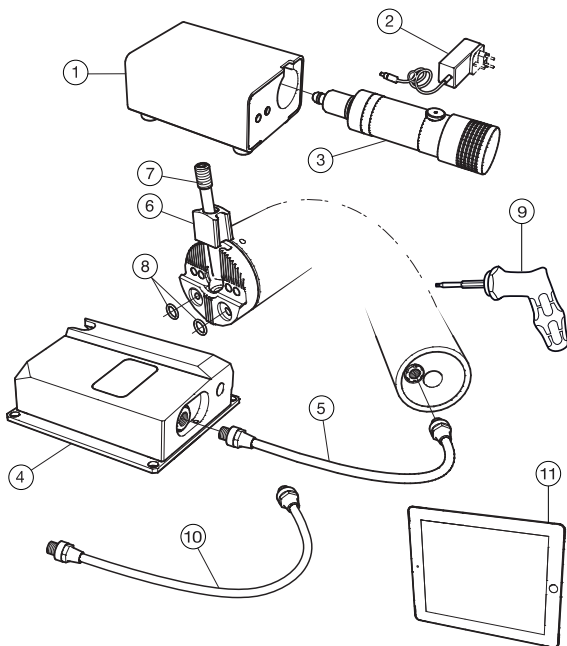

Spare parts								Included parts	Accessories	
1	2	3	4	5	6	7	8	9	10	11
Battery charger	Power supply charger	Battery (2 batteries/KIT)	Electronic unit (1 output)	Cable (300 mm)	Wedge	Screw	O-rings	Torque wrench	Cable (500 mm)	Windows tablet
7120 110-01	7110 010-01	7130 110-01	7210 110-01	7310 110-01	5431 015-01	5516 014-09	5641 005-153	5680 100-10	7310 110-02	7410 010-01





# Silent Tools™ Plus

North American version



ENG

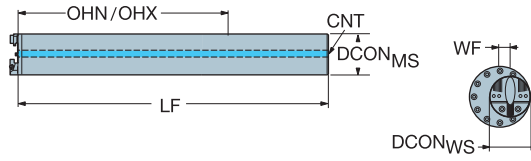

							Dimensions, inch						
CZC <sub>MS</sub>	CZC <sub>WS</sub>	OHN	OHX	CNSC	CXSC	Ordering code	DCON <sub>MS</sub>	DCON <sub>WS</sub>	LF	WF	CNT	PSI	LBS
2 1/2	40mm	21.500	21.500	1	1	TA60D-CYA40B810W4RB	2.500	40mm	31.890	.463	G1/8	2175	33
3	40mm	30.000	30.000	1	1	TA60D-CYA48B1090W4RB	3.000	40mm	42.913	.713	G1/8	2175	88
4	40mm	40.000	40.000	1	1	TA60D-CYA64B1410W4RB	4.000	40mm	55.512	1.213	G1/8	2175	176

The ordering codes above are kits containing all the hardware you will need, but when ordering a Silent Tools Plus adaptor kit, you also need to order a service pack.

Service pack ordering code:  
 ST P VIBRATION 001 (Yearly license)  
 ST P VIBRATION 101 (One time fee)

## Spare parts

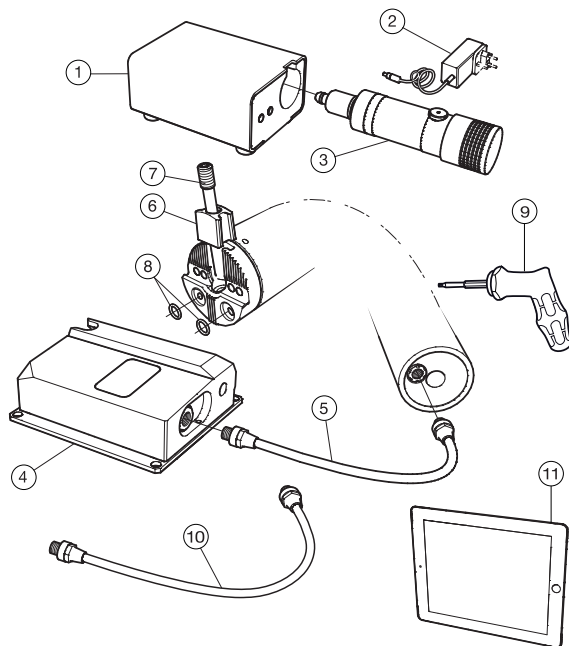

Spare parts								Included parts	Accessories	
1	2	3	4	5	6	7	8	9	10	11
Battery charger	Power supply charger	Battery (2 batteries/KIT)	Electronic unit (1 output)	Cable (300 mm)	Wedge	Screw	O-rings	Torque wrench	Cable (500 mm)	Windows tablet
7120 110-01	7110 010-01	7130 110-01	7210 110-01	7310 110-01	5431 015-01	5516 014-09	5641 005-153	5680 100-10	7310 110-02	7410 010-01



# Silent Tools™ Plus

## Wedge Lock cutting heads



	DMIN <sub>1</sub>	Ordering code	Dimensions, mm, inch				MIID	
			DCON	LF	WF	KAPR		
	50.0	<b>TITR-W4R-D13U-27A</b>	40	29.0	27.0	93.0°	TR-DC 13 08	
	1.969		1.575	1.142	1.063			
	50.0	<b>TIP0-W4R-C12L-27A</b>	40	31.0	27.0	95.0°	CNMG 12 04 08	
	1.969		1.575	1.220	1.063			
	50.0	<b>TI07-W4R-C09L-27A</b>	40	28.0	27.0	95.0°	CCMT 09 T3 08	
	1.969		1.575	1.102	1.063			
	50.0	<b>TIP0-W4R-D15U-27A</b>	40	30.0	27.0	93.0°	DNMG 15 04 08	
	1.969		1.575	1.181	1.063			
	50.0	<b>TITR-W4R-D13UX27A</b>	40	18.0	37.5	27.0	93.0°	TR-DC 13 08
	1.969		1.575	.709	1.476	1.063		

# Silent Tools™ Plus

Engineered solutions



When ordering a Silent Tools Plus adaptor kit, you need to order a service pack.

Service pack ordering code for engineered products:  
 ST P VIBRATION-LOAD 001 (Yearly license)  
 ST P VIBRATION-LOAD 201 (One time fee)

Diameter (mm)	Overhang (xD)				
	8	10	12	14	16
60		Standard			N/A
80					
100			Engineered: Vibration- and load sensor		
120					
140			Engineered: Vibration sensor		
160					
Up to 300					

## Spare parts

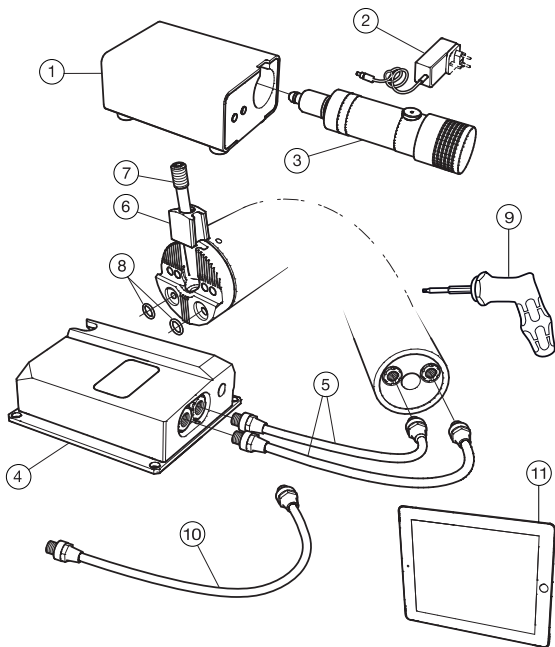

Spare parts								Included parts	Accessories	
1	2	3	4	5	6	7	8	9	10	11
Battery charger	Power supply charger	Battery (2 batteries/KIT)	Electronic unit (2 outputs)	Cable (300 mm)	Wedge	Screw	O-rings	Torque wrench	Cable (500 mm)	Windows tablet
7120 110-01	7110 010-01	7130 110-01	7210 110-02	7310 110-01	5431 015-01	5516 014-09	5641 005-153	5680 100-10	7310 110-02	7410 010-01

Head office:  
AB Sandvik Coromant  
SE-811 81 Sandviken, Sweden  
E-mail: [info.coromant@sandvik.com](mailto:info.coromant@sandvik.com)  
[www.sandvik.coromant.com](http://www.sandvik.coromant.com)

C-2900:162 en-GB © AB Sandvik Coromant 2018

