

3M

Accessories for Abrasive Products



Disc Accessories

Scotch-Brite™ Radial Bristle
Product Accessories

Wheel Accessories

Belt Accessories

Hand Sanding Accessories

Dispensers

Spindles and Mandrels

Finesse-it™ System
Accessories

Packs and Kits

Finesse-it™ Polish

Finesse-it™ Compounds



Additional accessories are available and may be purchased directly through Contract Production Services/CPS. Please contact Contract Production Services/CPS directly to check availability and other specific information. Use the part number to identify any specific item.

Order from:

Contract Production Services/CPS

also known as:

Commercial Products (CMPRO)

Vision Loss Resources (VLR)

VH Industries (VHI)

1936 Lyndale Ave. S.
Minneapolis, MN 55403

Phone: 800-843-0619

612-871-2222

Fax: 612-872-0189

www.VLRW.com

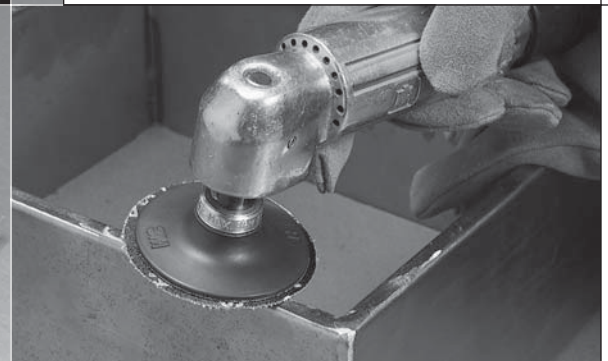
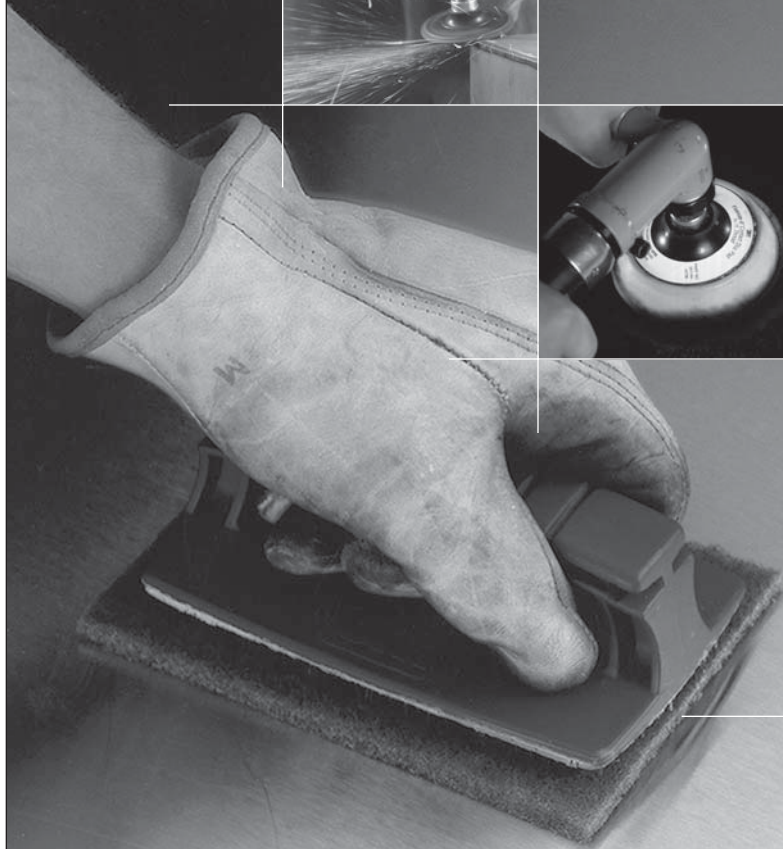

Disc Accessories

3M™ Disc Pad Face Plate1

3M™ Disc Pad Face Plate — Smooth1

3M™ Disc Pad Face Plate — Ribbed1

3M™ Disc Pad Hub.....2

3M™ Disc Retainer Nut.....2

3M™ Fibre Disc Backup Pad2

3M™ Disc Holder Adaptor No. 92

3M™ TN Quick Change Fibre Disc Backup Pad2

3M™ Flap Disc Adaptor Nut3

3M™ Flap Disc Holder3

3M™ Flexible Grinding Wheel Backup Pad3

3M™ PSA Disc Holder3

3M™ Roloc™ TR Disc Pad4

3M™ Roloc™ TR Disc Pad (Bulk Package)4

3M™ Roloc™ TR Disc Pad Assembly5

3M™ Roloc™ TR Disc Pad Assembly (Bulk Package)5

3M™ Roloc™ TP Disc Pad5

3M™ Roloc™ TS or TSM Disc Pad5

3M™ Roloc™ Shank.....6

3M™ Roloc™ Adaptor Kit.....6

3M™ Roloc™ TS & TSM Mandrel.....6

3M™ Roloc™ Dust-Free Disc Pad.....6

3M™ Roloc™+ Holder6

3M™ Roloc™ PSA Disc Pad6

Hook Types.....7

3M™ Hookit™ Roloc™ Disc Pad Type J7

3M™ Hookit™ II Roloc™ Disc Pad.....7

3M™ Disc Pad8

3M™ Feathering Disc Adhesive8

3M™ Stikit™ Disc Pad.....8

3M™ Stikit™ Low Profile Disc Pad.....9

3M™ Stikit™ Low Profile Finishing Disc Pad.....9

3M™ Stikit™ Soft Interface Pad9

3M™ Stikit™ Dust-Free Disc Pad10

3M™ Stikit™ Dust-Free Low Profile Disc Pad10

3M™ Stikit™ Dust-Free Low Profile Finishing Disc Pad.....10

3M™ Stikit™ Center Water Feed (CWF) Disc Pad.....11

3M™ Quick-Change Short Hex Adaptor Kit11

3M™ Hookit™ Disc Pad11

3M™ Hookit™ Low Profile Disc Pad12

3M™ Hookit™ Low Profile Finishing Disc Pad12

3M™ Hookit™ Dust-Free Disc Pad12

3M™ Hookit™ Dust-Free Low Profile Disc Pad13

3M™ Hookit™ Dust-Free Low Profile Finishing Disc Pad13

3M™ Hookit™ Soft Interface Pad.....13

3M™ Hookit™ SBS Backup Pad.....13

3M™ Hookit™ Center Water Feed (CWF) Disc Pad14

3M™ Hookit™ Hard Disc Pad Center Water Feed (CWF) Type J14

3M™ Hookit™ II Disc Pad14

3M™ Hookit™ II Low Profile Disc Pad.....15

Disc Accessories – continued

3M™ Hookit™ II Low Profile Finishing Disc Pad15
 3M™ Hookit™ II Dust-Free Disc Pad15
 3M™ Hookit™ II Dust-Free Low Profile Disc Pad.....16
 3M™ Hookit™ II Dust-Free Low Profile Finishing Disc Pad16
 3M™ Hookit™ II Soft Interface Disc Pad.....16
 3M™ Conversion Face.....16
 3M™ Disc Pad Holder (Hook-and-Loop)17

Scotch-Brite™ Radial Bristle Product Accessories

3M™ Flange Adaptor18
 3M™ Tapered Spindle Mount Adaptor.....18
 3M™ Brush Extendor Adaptor18
 3M™ Flange Set.....18
 3M™ Mandrel.....18
 3M™ SR Cutter Adaptor18

Wheel Accessories

3M™ Roloc™+ Button19
 3M™ Roloc™+ Button Combination Pack19
 3M™ Wheel Adaptor No. 81A.....19
 3M™ Wheel Adaptor Kit No. 2.....19
 3M™ Wheel Adaptor Kit No. 319
 3M™ Flange Adaptor Kit No. 319
 3M™ Flange Adaptor No. 520
 3M™ Flange No. 35620
 3M™ Flange No. 40020
 3M™ Spindle Extendor Kit No. 30020
 3M™ Mandrels No. 931, 932 and 93321
 3M™ Mandrel No. 93421
 3M™ Mandrel No. 93621
 3M™ Mandrel No. 99021
 3M™ Wide Brush and Wheel Dressing Material21
 3M™ Wheel Dressing and Shaping Tape 80.....21
 3M™ Resin Bond Cloth PSA #40.....22
 3M™ RX Hub22–23

Belt Accessories

3M™ Rubber Cushion Polishing Wheel24–25
 3M™ Rubber Expander Wheel.....25
 3M™ Scotchlite™ Platen Pad Cover25

Hand Sanding Accessories

3M™ Screen Cloth Disc Hand Pad.....26
 3M™ Stikit™ Hand Pad26
 3M™ Stikit™ Soft Hand Pad.....26

Hand Sanding Accessories – continued

3M™ Stikit™ Disc Hand Pad26
 3M™ Sanding Block26
 3M™ Hookit™ Disc Hand Pad.....27
 3M™ Hookit™ II Disc Hand Pad.....27
 3M™ Center Water Feed (CWF) Disc Hand Pad.....27
 3M™ Center Water Feed (CWF) Disc Hand Pad Replacement Sponge.....27
 3M™ Wetordry™ Sponge Pad No. 2028
 3M™ Stikit™ Hand Block28
 3M™ Stikit™ Soft Hand Block.....28
 3M™ Stikit™ Sanding Block.....28
 3M™ Stikit™ Hand File Board28
 3M™ Hookit™ Hand Block28
 3M™ Hookit™ Soft Hand Block29
 3M™ Wooden Hand Block.....29
 3M™ Hookit™ Hand File Board.....29
 3M™ Hookit™ Facing Roll.....29
 3M™ Hookit™ II Hand Block29
 3M™ Hookit™ II Soft Hand Block29
 3M™ Hookit™ II Hand File Board.....29
 3M™ Twist-Lok™ Pad Holder No. 96130
 3M™ Insta-Lok™ Hand Block 95230
 3M™ Doodlebug™ Pad Holder 25030
 Scotch-Brite™ Conformable Applicator Cleaner Head 26130

Dispensers

3M™ Stikit™ Double Roll Dispenser30
 3M™ Stikit™ Roll Dispenser30

Spindles and Mandrels

3M™ Square/Cross Pad Mandrel31
 3M™ Spindle and Mandrel.....31
 3M™ Mini Mandrel No. 93531
 3M™ Mandrel No. 94431

Miscellaneous Accessories

3M™ Stikit™ Air File Shoe.....32
 3M™ Hookit™ Air File Shoe32
 3M™ Wetordry™ Rubber Squeegee.....32
 3M™ Dual Lock™ Tape, Type 400.....32
 3M™ Paint Buster™ Hand Cleaner32
 3M™ Roto Peen Assembly Kit.....32
 3M™ Heavy Duty Roto Peen Hub Assembly.....33
 3M™ Heavy Duty Roto Peen Spacer Ring.....33
 3M™ Roto Peen Mandrels 7210, 7211 and 7212.....33
 3M™ Roto Peen Almen Strip Holder33
 3M™ Fladder Blade Spacer Ring.....33

Finesse-it™ System Accessories

3M™ Finesse-it™ Hand Sanding Pad34
 3M™ Finesse-it™ Interface Disc Pad—Soft.....34
 3M™ Finesse-it™ Disc Pad34
 3M™ Finesse-it™ Roloc™ Sanding Pad34
 3M™ Finesse-it™ Roloc™ Finishing Disc Pad34
 3M™ Finesse-it™ Sanding Pencil.....34
 3M™ Finesse-it™ Buffing Pad.....35
 3M™ Finesse-it™ Natural Buffing Pad35
 3M™ Finesse-it™ Knit Buffing Pad35
 3M™ Finesse-it™ Knit II Buffing Pad.....36
 3M™ Perfect-it™ Foam Compounding Pad36
 3M™ Perfect-it™ III Wool Compounding Pad36
 3M™ Perfect-it™ Hookit™ Foam Polishing Pad36
 3M™ Finesse-it™ Hookit™ Foam Buffing Pad.....36
 3M™ Finesse-it™ Hookit™ Polishing Pad36
 3M™ Finesse-it™ Contact Disc Pad37
 3M™ Superbuff™ Buffing Pad.....37
 3M™ Superbuff™ 2 Plus 2 Buffing Pad.....37
 3M™ Superbuff™ Polishing Pad37
 3M™ Superbuff™ Adaptor.....37
 3M™ Hookit™ SBS Backup Pad.....37

Packs and Kits

Scotch-Brite™ Hand Pad Trial Pack No. 961S38
 3M™ NTN Maintenance and Repair Kit.....38
 Scotch-Brite™ Coating Removal Disc Pack.....38
 Scotch-Brite™ Roloc™ Bristle Disc Intro Pack38
 3M™ Roloc™ Intro Disc Pack.....38
 3M™ Roloc™ Disc Pack.....39
 Scotch-Brite™ Roloc™ Surface Conditioning Disc Pack.....39
 Scotch-Brite™ Unitized Wheel Intro Pack39
 Scotch-Brite™ Star Intro Pack.....39
 Scotch-Brite™ Surface Conditioning Disc Intro Pack39
 Scotch-Brite™ Unitized Wheel Intro Pack40
 Scotch-Brite™ EXL Unitized Wheel Intro Pack40
 Scotch-Brite™ EXL Deburring Wheel Intro Pack40

Finesse-it™ Polish

3M™ Finesse-it™ Finishing Material41
 3M™ Finesse-it™ Final Finish.....41
 3M™ Finesse-it™ Polishes41

Finesse-it™ Compounds

3M™ Finesse-it™ Compounding Material.....42
 3M™ Finesse-it™ Finishing Material42
 3M™ Finesse-it™ Marine Paste Compound42
 3M™ Glass Polishing Compound.....42

Index of Part # / UPC # / 3M ID 43–46

3M™ Disc Pad Face Plate

3M Disc Pad Face Plates can be easily changed without removing the hub.

Allows the operator to use a single tool for multiple applications from grinding to finishing a work piece.

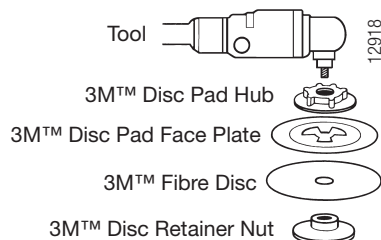

3M Disc Face Plates are available in the following densities to meet various applications:

Color	Description	Applications
Red	Extra Hard	Heavy grinding
Black	Hard	Heavy metal removal, large welds, etc
Gray	Medium	General purpose grinding and finishing — normal flexibility
White	Soft	Finishing operations — flexible, follows contours

3M™ Disc Pad Face Plate — Smooth

The lightweight construction provides excellent balance and low profile for better operator handling. 3M Disc Pad Face Plates are also designed to resist chunking, reduce edge wear, and are tapered to fit the disc shape to minimize flare and wild scratches. The system works with fibre or surface conditioning discs with 7/8" center hole.

Size Diameter	Description	Part #	UPC	Max RPM	Qty/Case
4-1/2"	Black—Hard	14270	051144-14270-5	13,300	10
	Gray—Medium	13325	051144-13325-3	13,300	10
5"	Black—Hard	45206	051144-45206-4	12,000	10
	Gray—Medium	45207	051144-45207-1	12,000	10
	White—Soft	45208	051144-45208-8	12,000	10
7"	Black—Hard	45192	051144-45192-0	8,600	10
	Gray—Medium	45193	051144-45193-7	8,600	10
	White—Soft	45194	051144-45194-4	8,600	10
9"	Black—Hard	45195	051144-45195-1	6,600	10

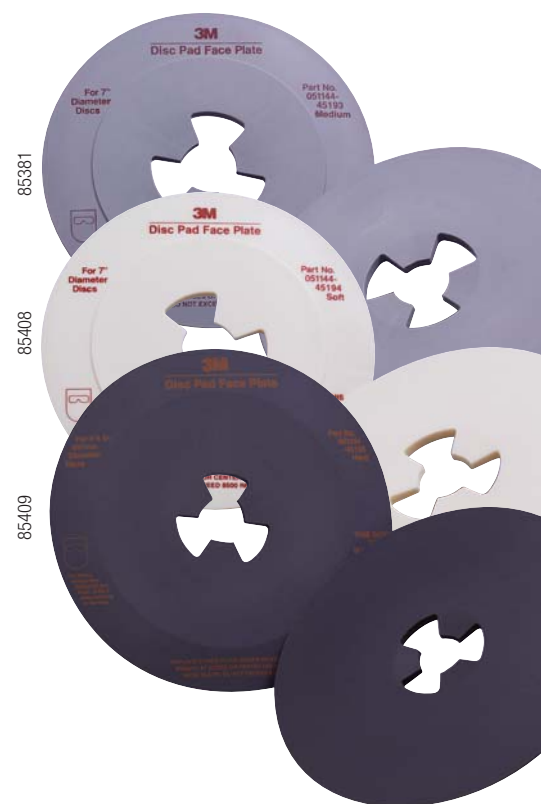

3M™ Disc Pad Face Plate — Ribbed

3M ribbed face plates result in cooler running discs. The ribbed sections provide higher unit pressure at the grinding interface which aids mineral breakdown resulting in prolonged disc life, especially if dulling is a problem. Available in 5", 7" and 9" diameters.

Size Diameter	Description	Part #	UPC	Max RPM	Qty/Case
5"	Red—Extra Hard	81732	051144-81732-0	12,000	10
	Black—Hard	81733	051144-81733-7	12,000	10
	Gray—Medium	81734	051144-81734-4	12,000	10
	White—Soft	81735	051144-81735-1	12,000	10
7"	Red—Extra Hard	80514	051144-80514-3	8,600	10
	Black—Hard	80515	051144-80515-0	8,600	10
	Gray—Medium	80516	051144-80516-7	8,600	10
	White—Soft	80517	051144-80517-4	8,600	10
9"	Red—Extra Hard	81728	051144-81728-3	6,600	10
	Black—Hard	81729	051144-81729-0	6,600	10





51694

158140

95268

3M™ Disc Pad Hub

Disc Pad Hubs have a 5/8"–11 threaded metal insert and are designed to be used with 3M Disc Pad Face Plates.

Size	Description	Part #	UPC	Qty/Inner	Qty/Case
2-1/2"	For 4-1/2" – 9" Face Plates	45205	051144-45205-7	1	10
	For Short Shaft Tools	88743	051144-88743-9	1	10
	For Grit-lok™ Fibre Discs	11824	051144-11824-3	1	10
4-1/2"	For 7" & 9" Plates	45190	051144-45190-6	1	10
	For 7" & 9" Face Plates (old style)	86100	051111-60306-2	1	10
	For Grit-lok™ Fibre Discs	11823	051144-11823-6	1	10

3M™ Disc Retainer Nut

For use with all 3M Disc Pad Face Plates, 3M and Spiralcool Disc Pads, and 3M Disc Pad Hubs. The nuts have 5/8"–11 threaded arbor hole in three lengths and 1/4" holes for use with spanner wrench.

Size	Part #	UPC	Qty/Inner	Qty/Case
3/8" x 5/8" –11	05622	051144-05622-4	—	10
5/16" x 5/8" –11	02618	051111-51047-6	1	10
1/2" x 5/8" –11	05621	051144-05621-7	—	10
5/8" x 5/8" –11	05620	051144-05620-0	—	10



85331

3M™ Fibre Disc Backup Pad

Backup pad designed for supporting 5" diameter x 7/8" center hole fibre discs on smaller format right angle grinders (e.g. pistol grip Sanders). This backup pad does not require a 3M Disc Pad Hub; uses retainer nut supplied with the sander.

Size	Part #	UPC	Max RPM	Qty/Case
5" x 7/8"	05637	051131-05637-4	18,000	10

3M™ Disc Holder Adaptor No. 9

These adaptors will convert a sander with M10–1.25, M10–1.50 or 3/8"–24 external threaded shaft to a 5/8"–11 external threaded shaft. Use with 5/8"–11 Disc Holders 914, 9145 and 915.

Size	Part #	UPC	Qty/Inner	Qty/Case
5/8"–11 EXT 3/8"–24 INT	9	048011-22970-6	10	10
5/8"–11 EXT M10-1.25 INT	9	048011-22971-3	10	10
5/8"–11 EXT M10-1.50 INT	9	048011-22972-0	10	10

3M™ TN Quick Change Fibre Disc Backup Pad

The TN platform allows the operators to change 3M products as needed, without using any tools. The TN platform eliminates the need for retainer nuts and spanner wrenches. Use with TN discs.

Size	Part #	UPC	Max RPM	Qty/Inner	Qty/Case
4-1/2" x 5/8"–11 INT	02140	051111-56573-5	13,300	1	5



51699

352092

3M™ Flap Disc Adaptor Nut

Adaptor nut to be used with 3M Flap Discs.

Size	Part #	UPC	Qty/Case
5/8"–11 INT	88765	051144-88765-1	5



3M™ Flap Disc Holder

Holder for 7" diameter 3M Flap Discs and 6" diameter Scotch-Brite™ Clean and Strip Cup Wheel.

Size	Part#	UPC	Qty/Case
4" x 5/8"–11 INT	88769	051144-88769-9	1



3M™ Flexible Grinding Wheel Backup Pad

The clear backup pad is required for safe operation of 3M Flexible Grinding Wheels with 7/8" center hole.

Size	Description	Part #	UPC	Qty/Inner	Qty/Case
3-3/8" x 7/8"	For 4-1/2" x 7/8" Wheels	51046	051111-51046-9	5	100
4-5/8" x 7/8"	For 7" x 7/8" Wheels	51045	051111-51045-2	5	100



3M™ PSA Disc Holder

3M PSA Disc Holders can be used with any electric or air grinding tool that accommodates 1/4" shank. Provides excellent PSA disc support when grinding hard-to-get-at areas.

Size	Part #	UPC	Max RPM	Qty/Inner	Qty/Case
3/4" x 1/4"	45073	051144-45073-2	20,000	—	250
1" x 1/4"	45072	051144-45072-5	20,000	—	250
1-1/2" x 1/4"	45071	051144-45071-8	20,000	—	120
2" x 1/4"	45070	051144-45070-1	15,000	—	50
3" x 1/4"	05510	051144-05510-4	10,000	10	10
4" x 1/4"	45069	051144-45069-5	7,500	—	10
5" x 1/4"	45068	051144-45068-8	6,000	—	4



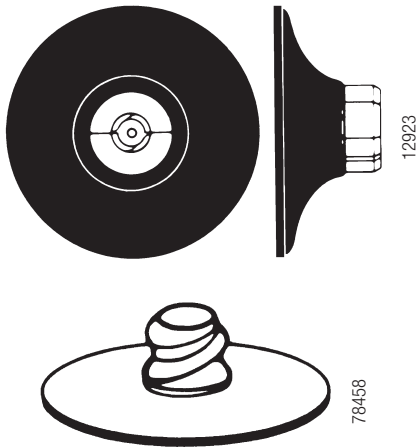

3M™ Roloc™ TR Disc Pad

Rubber backup pad available in different degrees of hardness for varying grinding applications. Backup pad designed to support 3M Roloc abrasive discs. This pad has a 1/4"–20 INT thread which allows it to be mounted directly to tools with 1/4"–20 EXT threaded shaft or use with Roloc shank to fit collet chuck tools.

Size	Description	Part #	UPC	Max RPM	Qty/Inner	Qty/Case
1/4"–20 INT						
1-1/2"	Soft	45098	051144-45098-5	30,000	5	5
	Medium	45099	051144-45099-2	30,000	5	5
	Hard	45100	051144-45100-5	30,000	5	5
1"	Medium	45101	051144-45101-2	30,000	5	5
2"	Soft	45094	051144-45094-7	20,000	5	5
	Medium	45095	051144-45095-4	25,000	5	5
	Hard	45096	051144-45096-1	25,000	—	5
	Extra Hard	45097	051144-45097-8	25,000	5	5
3"	Soft	45090	051144-45090-9	15,000	5	5
	Medium	45092	051144-45092-3	18,000	5	5
	Hard	45091	051144-45091-6	20,000	—	5
	Extra Hard	45093	051144-45093-0	20,000	5	5
4"	Medium	45179	051144-45179-1	12,000	5	5
3/8"–24 INT						
3"	Hard	88748	051144-88748-4	20,000	5	5
5/8"–11 INT						
3"	Soft	82879	051111-55765-5	15,000	5	5
4"	Medium	83242	051144-83242-2	12,000	5	5
	Hard	83489	051144-83489-1	12,000	5	5
	Extra Hard	83980	051144-83980-3	12,000	5	5
M10–1.5 INT						
75mm	Medium	85001	051144-85001-3	18,000	1	5
	Hard	85000	051144-85000-6	20,000	1	5
M14–2.0 INT						
75mm	Soft	84994	051144-84994-9	15,000	5	5
	Medium	84999	051144-84999-4	18,000	5	240
	Hard*	84998	051144-84998-7	20,000	5	240
	Extra Hard	84993	051144-84993-2	20,000	5	5

Must be ordered in full case quantities. Order threaded shaft separately.
*OUS only.

3M™ Roloc™ TR Disc Pad (Bulk Package)

Bulk packages do not include 1/4" Roloc shank.

Size	Description	Part #	UPC	Max RPM	Qty/Inner	Qty/Case
2"	Hard	88746	051111-51155-8	25,000	50	50
3"	Hard	01920	051111-60315-4	20,000	200	200
4"	Medium	84997	051144-84997-0	12,000	125	125

3M™ Roloc™ TR Disc Pad Assembly

Assembly includes one pad, one 1/4" Roloc shank and one Roloc adaptor (1/4"–20 EXT to 7/16"–20 INT).

Size	Description	Part #	UPC	Max RPM	Qty/ Inner	Qty/ Case
1"	Hard	05538	051131-05538-4	30,000	1	10
2"	Hard	05539	051144-05539-5	25,000	1	10
3"	Hard	05540	051144-05540-1	20,000	1	10
4"	Medium	05541	051131-05541-4	12,000	1	10



3M™ Roloc™ TR Disc Pad Assembly (Bulk Package)

Size	Description	Part #	UPC	Max RPM	Qty/ Inner	Qty/ Case
2"	Hard	70446	051111-60312-3	25,000	250	250
3"	Hard	70448	051111-60313-0	20,000	125	125

3M™ Roloc™ TP Disc Pad

For use with 3M Roloc TP Discs or with other "press on" type abrasive discs. Backup pad designed to support 3M Roloc TP Abrasive Discs. Pad has a 1/4"–20 INT thread which allows it to be mounted directly to tools with 1/4"–20 EXT threaded shafts or used with a Roloc Shank to fit collet chuck tools.

Size	Description	Part #	UPC	Max RPM	Qty/ Inner	Qty/ Case
1"	Medium	77723	051144-77723-5	30,000	5	5
1-1/2"	Medium	77726	051144-77726-6	30,000	1	5
2"	Medium	14197	051144-14197-5	25,000	5	5
	Hard	14198	051144-14198-2	25,000	5	5
3"	Medium	14201	051144-14201-9	18,000	5	5
	Hard	14202	051144-14202-6	20,000	5	5

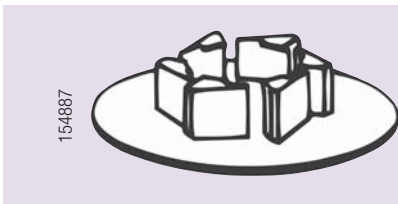
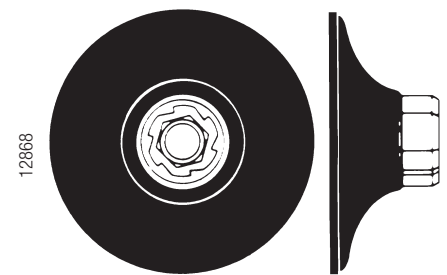

3M™ Roloc™ TS or TSM Disc Pad

For use with 3M Roloc TS or TSM Discs and other type "screw-on" abrasive discs. Backup pad designed to support 3M Roloc TS or TSM Abrasive Discs. Pad has a 1/4"–20 INT thread which allows it to be mounted directly to tools with 1/4"–20 EXT threaded shafts or used with a Roloc Shank to fit collet chuck tools.

Size	Description	Part #	UPC	Max RPM	Qty/ Inner	Qty/ Case
1"	Medium	77724	051144-77724-2	30,000	5	5
1-1/2"	Medium	77729	051144-77729-7	30,000	5	5
	Hard	77728	051144-77728-0	30,000	5	5
2"	Medium	14211	051144-14211-8	25,000	5	5
	Hard	14212	051144-14212-5	25,000	5	5
3"	Medium	14215	051144-14215-6	18,000	5	5
	Hard	14216	051144-14216-3	20,000	5	5
4"	Medium	77740	051144-77740-2	12,000	5	5

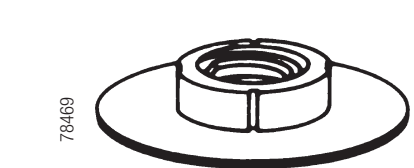
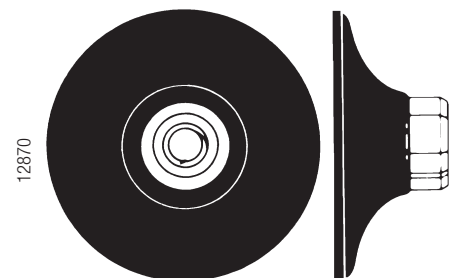

3M™ Roloc™ Shank

Shaft has shank to fit collet chucks or drill chucks and 1/4"–20 EXT thread to fit Roloc Disc Pads with 1/4"–20 EXT threads.

Size	Part #	UPC	Qty/Case
1/4"	45102	051144-45102-9	50
6mm	82455	051144-82455-7	100

3M™ Roloc™ Adaptor Kit

7/16"–20 Internal x 1/4"–20 External. Used to attach a Roloc Disc Pad to a pistol grip tool with 7/16"–20 External thread.

Size	Part #	UPC	Qty/Inner	Qty/Case
7/16"–20 INT x 1/4"–20 EXT	02155	051111-60525-7	1	50

3M™ Roloc™ TS & TSM Mandrel

Use with 3/4" Roloc TS & TSM discs. Designed for cleaning and finishing of airplane seat track channels.

Size	Part #	UPC	Qty/Case
1/4" x 2"	85097	051144-85097-6	5

3M™ Roloc™ Dust-Free Disc Pad

For use with tools with vacuum shrouds or for cooling discs in high heat generating applications. (Dust shrouds made to order.) Use with 1/4" x 1/4"–20 threaded shank or adaptor supplied with vacuum shroud kits.

Size	Description	Part #	UPC	Max RPM	Qty/Inner	Qty/Case
3"	—	82975	051144-82975-0	12,000	5	5
4"	Hard	02286	051111-56479-0	12,000	5	5

3M™ Roloc™+ Holder

Rugged, plastic holder provides support for all Roloc products including discs and combi wheels. Holder has deeper internal thread to accept products with Roloc+ buttons.

Size	Part #	UPC	Max RPM	Qty/Case
1"	1	048011-15408-4	25,000	5

3M™ Roloc™ PSA Disc Pad

Smooth skin of neoprene foam provides a resilient base when using PSA discs. Pads must be used with proper Roloc Disc Pad hardware.

Size	Part #	UPC	Max RPM	Max OPM	Qty/Inner	Qty/Case
1"	85299	051144-85299-4	10,000	10,000	10	50
1-1/2"	85286	051144-85286-4	10,000	10,000	5	50
2"	85287	051144-85287-1	10,000	10,000	5	50



Hook Types

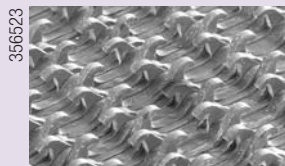

Hook Type 1
3M™ Hookit™ Small Molded J Hook



Hook Type 2
3M™ Hookit™ Tall J Hook

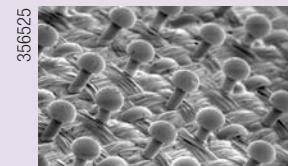

Hook Type 3
3M™ Hookit™ Mushroom Hook

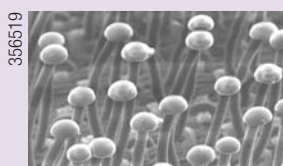

Hook Type 4
Hook-and-Loop Tall Mushroom Hook (250HD)

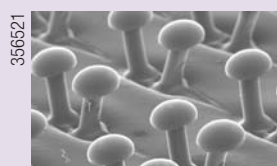

Hook Type 5
3M™ Dual Lock™ Hook Type 170

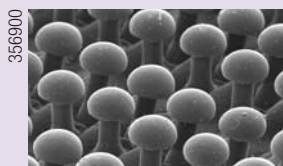

Hook Type 6
3M™ Dual Lock™ Hook Type 400



Hook Type 7
Hook-and-Loop T Hook

3M™ Hookit™ Roloc™ Disc Pad Type J

Tall J-Hook material attached to soft neoprene foam which provides a resilient base when using QRS flexible diamond discs. This allows for easy micron grade change. Pad must be used with proper Roloc Disc Pad hardware.

Size	Hook Type*	Part #	UPC	Max RPM	Max OPM	Qty/ Case
1"	2	82564	051144-82564-6	8,000	10,000	10
1-1/4"	2	67415	051111-60311-6	10,000	10,000	20
1-1/2"	2	82565	051144-82565-3	8,000	10,000	5
2"	2	82566	051144-82566-0	8,000	10,000	5
3"	2	82567	051144-82567-7	8,000	10,000	1

*See chart above for descriptions and photos of hook types.



211448

3M™ Hookit™ II Roloc™ Disc Pad

Size	Description	Part #	UPC	Max RPM	Qty/ Inner	Qty/ Case
1-1/4" x 5/16"	Medium—Roloc TR	02787	051111-60900-2	10,000	10	20

3M™ Disc Pad

Cloth face pad with lightweight, molded foam body. Discs are adhered to pad with 3M Feathering Disc Adhesive. 5" and 6" Disc Pads have a 5/16"—24 stud for use on dual action or random orbital disc sanders.



211416

Size Dia x Thickness	Part #	UPC	Max RPM	Max OPM	Qty/Case
5" x 3/4"	05577	051144-05577-7	10,000	12,000	10
6" x 3/4"	05578	051144-05578-4	10,000	12,000	10

3M™ Feathering Disc Adhesive

Net Wt.	Description	Part #	UPC	Bill Unit	Qty/Case
5 oz.	Feathering Disc Adhesive	08051	051135-08051-1	Tube	6

3M™ Stikit™ Disc Pad

These lightweight, shock-resistant pads have a tough vinyl face that provides excellent disc adhesion yet allows quick, easy disc removal. 5" and 6" Disc Pads are designed for use on dual action and random orbital sanders. Well-balanced pads made with a rugged, durable, plastic hub and foam body.



85318

Size Dia x Thickness	Face Color	Part #	UPC	Max RPM	Max OPM	Qty/Case
5/16"—24 EXT						
3-1/2" x 1/2"	Blue	82658	051144-82658-2	12,000	12,000	10
4" x 1/2"	Blue	81672	051144-81672-9	12,000	12,000	10
5" x 3/8"	Blue—Tapered Edge	88736	051144-88736-1	10,000	12,000	10
	Silver	85104	051144-85104-1	10,000	12,000	10
5" x 3/4"	Blue	05575	051144-05575-3	10,000	12,000	10
	Blue (Bulk)	05575B	051111-51170-1	10,000	12,000	50
	Silver	45215	051144-45215-6	10,000	12,000	10
	Red	81821	051144-81821-1	10,000	12,000	10
5" x 1-1/4"	Black—Soft	82178	051144-82178-5	7,500	12,000	10
	Rubber Face	54318	051111-56466-0	7,500	12,000	10
6" x 3/4"	Blue	05576	051144-05576-0	10,000	12,000	10
	Blue (Bulk)	05576B	051111-51172-5	10,000	12,000	50
	Silver	45216	051144-45216-3	10,000	12,000	10

5/8"—11 INT						
5" x 1/2"	Blue Vinyl—Medium	06612	051111-56460-8	10,000	—	10
	Blue—Firm	70234	051111-55813-3	10,000	—	5
5" x 3/4"	Red	82189	051144-82189-1	10,000	—	10
8" x 5/16"	Red	84231	051144-84231-5	6,000	—	1
8" x 11/16"	Red	82790	051144-82790-9	6,000	—	1
	Red	05558	051131-05558-2	5,000	—	1
	Blue—Soft	05568	051131-05568-1	3,000	—	1
8" x 1"	Blue—Soft	05568	051131-05568-1	3,000	—	1
	Blue	05579	051144-05579-1	3,000	—	1

6 Bolt Holes: Fits Chicago Pneumatic 777

8" x 3/8"	Blue	05582	051131-05582-7	1,500	10,000	1
-----------	------	-------	----------------	-------	--------	---

5 Bolt Holes: Fits National Detroit 900 or Dynabrade

8" x 3/8"	Blue	05581	051131-05581-0	1,500	10,000	1
-----------	------	-------	----------------	-------	--------	---

4 Bolt Holes: Fits Nitto Kohki

4" x 4-1/4" x 1/2"	Black	02223	051111-56456-1			5
--------------------	-------	-------	----------------	--	--	---



211371



211432



85314



100520

The color of the face side on a 3M™ Stikit™ Backup Pad will have a direct impact upon the performance of that pad.

Color	Description	Applications
Silver	Slightly lower than standard adhesion, easiest removal characteristics	High heat (woodworking)
Blue	Standard level of adhesion, standard removal characteristics	General purpose
Black	Standard level of adhesion, standard removal characteristics	General purpose
Brown	Standard level of adhesion, standard removal characteristics	General purpose
Red	Higher level of adhesion	High speed

3M™ Stikit™ Low Profile Disc Pad

Use with 3M Stikit Discs. Medium foam density and blunt 15° edge for good edge durability. Use with coarse grades and where good leveling is required.

Size Dia x Thickness	Face Color	Part #	UPC	Max RPM	Max OPM	Qty/Case
5/16"–24 EXT						
5" x 3/8"	Blue	05555	051131-05555-1	12,000	12,000	10
	Blue (Bulk)	05555B	051111-51173-2	12,000	12,000	50
6" x 3/8"	Blue	05556	051131-05556-8	10,000	12,000	10



100455

3M™ Stikit™ Low Profile Finishing Disc Pad

Specially designed for use with 3M Stikit Discs. Has a soft foam face (brown) construction for conformability and improved surface finish on sanded parts. Use with grade 220 and finer abrasive discs.

Size Dia x Thickness	Face Color	Part #	UPC	Max RPM	Max OPM	Qty/Case
5/16"–24 EXT						
5" X 11/16"	Brown—Soft	05545	051131-05545-2	12,000	12,000	10
6" X 11/16"	Brown—Soft	05546	051131-05546-9	10,000	12,000	10



100523

3M™ Stikit™ Soft Interface Pad

For use with 3M Stikit Discs. Use with Hookit Backup Pad to increase conformability to follow contours. (Hookit to Stikit)

Size Dia x Thickness	Face Color	Part #	UPC	Qty/Inner	Qty/Case
5" X 1/2"	Brown—Soft	02795	051111-56459-2	25	100

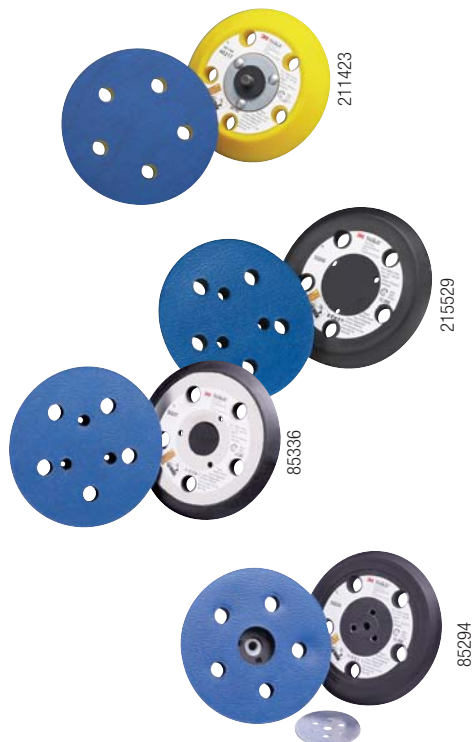

3M™ Stikit™ Dust-Free Disc Pad

For use with pre-punched 3M Stikit Dust-Free Discs to facilitate dust evacuation. Pads are lightweight, durable and well-balanced. All Dust-Free Disc Pads have the following dust hole patterns unless stated otherwise:

- 5" – Standard 5 holes pattern 500 FH
- 6" – Standard 6 holes pattern 600 HZ

Size Dia x Thickness	Face Color	Part #	UPC	Max RPM	Max OPM	Qty/ Case
5/16"–24 EXT						
5" x 3/8"	Blue (Bulk)	05655B	051111-51166-4	12,000	12,000	50
5" x 3/4"	Blue	45217	051144-45217-0	10,000	12,000	10
	Silver	82274	051144-82274-4	10,000	12,000	10
6" x 3/4"	Blue	45218	051144-45218-7	10,000	12,000	10
3 Bolt Holes: Fits Porter Cable Model 333 and 334						
5" x 1/2"	Blue	50206	051111-50206-8	12,000	12,000	5
3 Bolt Holes: Fits DeWalt Model DW421, 422, and 423						
5" x 1/2"	Blue	50207	051111-50207-5	12,000	12,000	5
7mm Bolt Hole: Fits Bosch 3107DVS						
5" x 1/2" x 1-1/8"	Blue	50208	051111-50208-2	12,000	12,000	5



3M™ Stikit™ Dust-Free Low Profile Disc Pad

Use with 3M Stikit Dust-Free Discs. Medium foam density and blunt 15° edge for good edge durability. Used for coarse grades and where good leveling is needed.

Size Dia x Thickness	Face Color	Part #	UPC	Max RPM	Max OPM	Qty/ Case
5/16"–24 EXT						
5" x 3/8"	Blue	05655	051131-05655-8	12,000	12,000	10
6" x 3/8"	Blue	05656	051131-05656-5	10,000	12,000	10

3M™ Stikit™ Dust-Free Low Profile Finishing Disc Pad

Specially designed for use with 3M Stikit Dust-Free Discs. Has a soft foam face (brown) construction for conformability and improved surface finish on sanded parts. Use with grade 220 and finer abrasive discs.

Size Dia x Thickness	Face Color	Part #	UPC	Max RPM	Max OPM	Qty/ Case
5/16"–24 EXT						
5" x 11/16"	Brown—Soft	05645	051131-05645-9	12,000	12,000	10
6" x 11/16"	Brown—Soft	05646	051131-05646-6	10,000	12,000	10

3M™ Stikit™ Center Water Feed (CWF) Disc Pad

This pad has a center hole for dispensing water through the disc to remove the sanding residue from the face of the disc. Primarily for glass polishing applications.

Size Dia x Thickness	Description	Part #	UPC	Max RPM	Qty/Case
5/8"–11 INT					
3" x 3/4" x 1/2"	5/8"–11 INT thread	01950	051111-56454-7	3,000	5
5" x 3/4" CH	Use with Quick Change Hex Adaptor	02599	051111-55792-1	10,000	5

3M™ Quick-Change Short Hex Adaptor Kit

Designed for use with 3M™ Stikit™ Center Water Feed Disc Pad PN02599. Comes with one adaptor and one spacer.

Size	Description	Part #	UPC	Qty/Case
3/4" Hex	5/8"–11 INT thread	02814	051111-55793-8	1

3M™ Hookit™ Disc Pad

Disc pads with attachment system for use with Hookit Discs, Surface Conditioning products and 3M™ Brushlon™ Type L Products.

Size Dia x Thickness	Description	Hook Type*	Part #	UPC	Max RPM	Max OPM	Qty/Case
5/16"–24 INT							
3" x 1/2"	Fits Snap-on AT402	2	05769	051131-05769-2	15,000	15,000	5
	Bulk Pack	2	06661	051111-60317-8	15,000	15,000	240
5/16"–24 EXT							
3" x 1/2"	Fits Dynabuffer 57125	2	02700	051111-55764-8	15,000	15,000	5
3-1/2" x 1/2"	—	1	82880	051144-82880-7	12,000	12,000	10
	—	3	05775	051131-05775-3	12,000	12,000	10
5" x 3/4"	45° tapered edge	1	13625	051144-13625-4	10,000	12,000	10
5" x 3/8"	—	1	70167	051111-55812-6	12,000	12,000	10
6" x 3/4"	—	3	05776	051131-05776-0	12,000	12,000	10
5/8"–11 INT							
3" x 11/16"	—	1	88739	051144-88739-2	6,000	—	5
5" x 3/4"	—	1	85105	051144-85105-8	10,000	—	10
5" x 5/8"	—	1	85096	051144-85096-9	10,000	—	10
7" x 1"	—	3	947	051144-13627-8	6,000	—	1
8" x 1"	Soft	3	05768	051131-05768-5	3,000	—	1
	—	3	05779	051131-05779-1	3,000	—	1
8" x 5/16"	Firm	1	77751	051144-77751-8	6,000	—	1
M14–2.0 INT							
178mm x 25mm	Use with 7" discs	3	07394	051131-07394-4	6,000	—	1
M8–1.25 INT							
5"	Fits Makita GV5000	2	18444	048011-18444-9	—	—	5
5 Bolt Holes							
8" x 3/8"	Fits National Detroit 900 & Dynabrade	3	05781	051131-05781-4	1,500	10,000	1
6 Bolt Holes							
8" x 3/8"	Fits Chicago Pneumatic 777	3	05782	051131-05782-1	1,500	10,000	1

* See chart on page 7 for descriptions and photos of hook types.

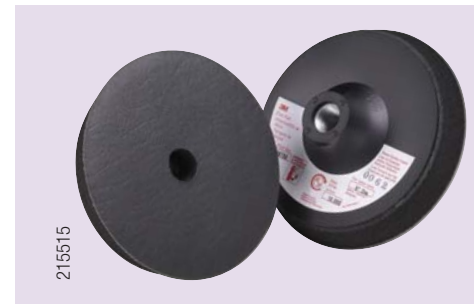

100461



100463

3M™ Hookit™ Low Profile Disc Pad

Specially designed for use with 3M Hookit Discs. Low profile design provides better leveling and faster removal rates when flat sanding. Pad is made with a medium density foam and has a blunt edge for edge durability.

Size Dia x Thickness	Hook Type*	Part #	UPC	Max RPM	Max OPM	Qty/Case
5/16"–24 EXT						
5" x 3/8"	3	05755	051131-05755-5	12,000	12,000	10
6" x 3/8"	3	05756	051131-05756-2	12,000	12,000	10

* See chart on page 7 for descriptions and photos of hook types.



85437

3M™ Hookit™ Low Profile Finishing Disc Pad

Designed for use with 3M Hookit Discs. Pad is made with a soft density foam for better conformability and allows the disc to flex which gives longer abrasive life in loading applications. Use with grade 220 and finer discs.

Size Dia x Thickness	Hook Type*	Part #	UPC	Max RPM	Max OPM	Qty/Case
5/16"–24 EXT						
5" x 11/16"	1	77855	051144-77855-3	12,000	12,000	10

* See chart on page 7 for descriptions and photos of hook types.



213730

3M™ Hookit™ Dust-Free Disc Pad

For use with 3M Hookit Dust-Free Discs.

Size Dia x Thickness	Comments	Hook Type*	Part #	UPC	Max RPM	Max OPM	Qty/Case
5/16"–24 EXT							
5" x 3/4"	—	1	82659	051144-82659-9	12,000	12,000	10
6" x 3/4"	—	3	05876	051131-05876-7	12,000	12,000	5
M8 EXT							
150mm	Fits Festo Sanders	3	07390	051131-07390-6	12,000	—	5
7mm Bolt Hole							
5" x 1/2" x 1-1/8"	Fits Bosch 3107DVS	1	50203	051111-50203-7	12,000	12,000	5
3 Bolt Holes							
5" x 1/2"	Fits DeWalt DW420; 421; 422 & 423	1	50204	051111-50204-4	12,000	12,000	5
	Fits Porter Cable 332; 333 & 334	1	50205	051111-50205-1	12,000	12,000	5

* See chart on page 7 for descriptions and photos of hook types.



100558



100538



86293



86291

3M™ Hookit™ Dust-Free Low Profile Disc Pad

Use with 3M Hookit Dust-Free Discs. Medium foam density and blunt 15° edge for good edge durability. Used for coarse grades and where good leveling is needed.

Size Dia x Thickness	Hook Type*	Part #	UPC	Max RPM	Max OPM	Qty/ Case
5/16"–24 EXT						
5" x 3/8"	3	05855	051131-05855-2	12,000	12,000	10
6" x 3/8"	3	05856	051131-05856-9	10,000	12,000	10

* See chart on page 7 for descriptions and photos of hook types.



3M™ Hookit™ Dust-Free Low Profile Finishing Disc Pad

For use with 5" 3M Hookit Dust-Free Discs (5 dust holes Die #500FH). Soft foam construction. Use in applications using grade 220 and finer abrasives. Use with coarse grade abrasives may cause premature foam failure.

Size Dia x Thickness	Description	Hook Type*	Part #	UPC	Max RPM	Max OPM	Qty/ Case
5/16"–24 EXT							
		1	77856	051144-77856-0	12,000	12,000	10
5" x 11/16"	Vacuum Grooves; Soft Mushroom Hook Face	3	67356	051111-56492-9	10,000	12,000	10
	Vacuum Grooves; Soft Mushroom Hook Face	1	84226	051111-51042-1	12,000	12,000	10

* See chart on page 7 for descriptions and photos of hook types.



3M™ Hookit™ Soft Interface Pad

For use with 3M Hookit Discs. Constructed of a soft durable foam. When used with a standard Hookit backup pad it increases conformability, allowing the technician to follow contours and get in closer to most edges.

Size Dia x Thickness	Description	Hook Type*	Part #	UPC	Qty/ Inner	Qty/ Case
3" x NH	—	3	05771	051131-05771-5	1	10
5" x 1/2"	J-Hook for Tricot Loop	2	70166	051111-56491-2	1	10
5" x 1/2" x 1"	5 Dust Holes	3	05773	051131-05773-9	1	10
6" x 1/2" x 1"	6 Dust Holes	3	05774	051131-05774-6	1	10

* See chart on page 7 for descriptions and photos of hook types.



3M™ Hookit™ SBS Backup Pad

3M Hookit SBS backup pad provides a quick change advantage yet produces exceptional finishes on today's paints. You get easy attachment, quick removal and accurate centering with either the compounding or polishing pad with the 3M Hookit Attachment System.

Size	Part #	UPC	Max RPM	Qty/ Inner	Qty/ Case
7" x 3/4"	05717	051131-05717-3	3,000	1	1



3M™ Hookit™ Center Water Feed (CWF) Disc Pad

Pad has a center hole for dispensing water through the disc to remove the sanding residue from the face of the disc. For use with 3M™ Flexible Diamond QRS Discs and other Hookit products. 7/8" center hole.



211368

Size Dia x Thickness	Hook Type*	Part #	UPC	Max RPM	Qty/Case
5/8"–11 INT					
3" x 5/16"	2	81349	051144-81349-0	9,000	1
4" x 5/16"	2	81350	051144-81350-6	9,000	1
5" x 5/16"	2	81351	051144-81351-3	8,500	1
6" x 5/16"	2	81352	051144-81352-0	8,500	1
7" x 5/16"	1	81353	051144-81353-7	8,000	1
8" x 5/16"	1	81933	051144-81933-1	8,000	1

* See chart on page 7 for descriptions and photos of hook types.

3M™ Hookit™ Hard Disc Pad Center Water Feed (CWF) Type J

Hook material attached to a hard backup pad which provides a firm base with center water feed when using QRS Flexible Diamond discs. This allows for easy micron grade change. Use with 5 inch diameter Hookit Discs. 5/8"–11 INT.



211443

Size Dia x Thickness	Hook Type*	Part #	UPC	Max RPM	Qty/Case
5" x 7/8"	2	82563	051144-82563-9	8,500	1

* See chart on page 7 for descriptions and photos of hook types.

3M™ Hookit™ II Disc Pads

Disc pads with attachment system for use with 3M Hookit II discs.

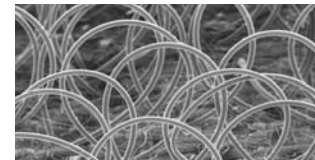

356902



213779

Size Dia x Thickness	Description	Part #	UPC	Max RPM	Max OPM	Qty/Case
5/16"–24 EXT						
3" x 1/2"	5/16"–24 INT	05269	051131-05269-7	15,000	15,000	5
	—	05270	051131-05270-3	15,000	15,000	5
3-1/2" x 1/2"	—	02134	051111-60899-9	12,000	12,000	10
5" x 3/8"	Full 5" Face Dia. 30° Taper	02507	051111-55830-0	12,000	12,000	10
5" x 3/4"	—	05275	051131-05275-8	12,000	12,000	10
6" x 11/16"	5" Full Face Dia.	02325	051111-55828-7	12,000	12,000	10
	Soft	05251	051131-05251-2	12,000	12,000	10
	Medium	05276	051131-05276-5	12,000	12,000	10
	Soft and Tapered Edge	05286	051131-05286-4	12,000	12,000	10
5/8"–11 INT						
5" x 5/8"	—	09347	051131-09347-8	12,000	—	5
8" x 1"	Medium	05279	051131-05279-6	5,000	—	1
5 Bolt Holes						
8" x 3/8"	National Detroit 900 or Dynabrade	05281	051131-05281-9	5,000	10,000	1



215524



100485



100687

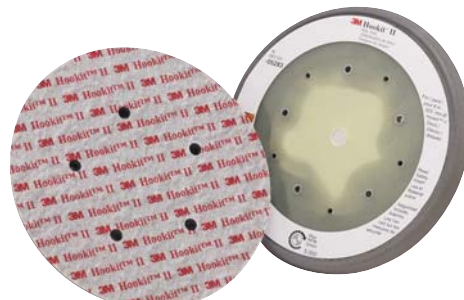

100589

Note: The red printing on Hookit™ II faces is being discontinued. All Hookit II faces will be plain white.

3M™ Hookit™ II Low Profile Disc Pad

Specially designed for use with 3M Hookit II Discs. Low profile design provides better leveling and faster removal rates when flat sanding. Pad is made with a medium density foam and has a blunt edge for edge durability.

Size Dia x Thickness	Description	Part #	UPC	Max RPM	Max OPM	Qty/Case
5/16"–24 EXT						
5" x 3/8"	Full 5" Face Dia.	02764	051111-55831-7	12,000	12,000	10
	—	05255	051131-05255-0	12,000	12,000	10
6" x 3/8"	—	02250	051111-56508-7	12,000	12,000	10



3M™ Hookit™ II Low Profile Finishing Disc Pad

Designed for use with 5" 3M Hookit II Discs. Pad is made with a soft density foam for better conformability and allows the disc to flex which gives longer abrasive life in loading applications. Use with grade 220 and finer discs.

Size Dia x Thickness	Description	Part #	UPC	Max RPM	Max OPM	Qty/Case
5/16"–24 EXT						
3-1/2" x 11/16"	Soft	02154	051111-56509-4	12,000	12,000	10
5" x 11/16"	Soft	05245	051131-05245-1	12,000	12,000	10



3M™ Hookit™ II Dust-Free Disc Pad

For use with pre-punched 3M Hookit II Dust-Free Discs to facilitate dust evacuation. Pads are lightweight, durable and well-balanced.

Size Dia x Thickness	Description	Part #	UPC	Max RPM	Max OPM	Qty/Case
5/16"–24 EXT						
5" x 3/4"	—	05375	051131-05375-5	12,000	12,000	10
6" x 11/16"	Primer Finishing	05351	051131-05351-9	12,000	12,000	10
6" x 3/4"	—	09352	051131-09352-2	12,000	12,000	5
5 Bolt Holes: Fits Bosch 3107DVS						
5-1/2" x 1-1/8"	7mm Bolt Hole	50200	051111-50200-6	12,000	12,000	5
3 Bolt Holes: Fits DeWalt DW420, 421, 422, and 423						
5" x 1/2"	—	50201	051111-50201-3	12,000	12,000	5
3 Bolt Holes: Fits Porter Cable 332, 333, and 334						
5" x 1/2"	—	50202	051111-50202-0	12,000	12,000	5



Note: The red printing on Hookit™ II faces is being discontinued. All Hookit II faces will be plain white.



213787

3M™ Hookit™ II Dust-Free Low Profile Disc Pad

Specially designed for use with 3M Hookit II Dust-Free Discs. Low profile design works on most standard dust-free type sanders and conversion kits designed for vacuum sanding.

Size Dia x Thickness	Part #	UPC	Max RPM	Max OPM	Qty/Case
5/16"–24 EXT					
5" x 3/8"	05355	051131-05355-7	12,000	12,000	10
6" x 3/8"	05356	051131-05356-4	12,000	12,000	10

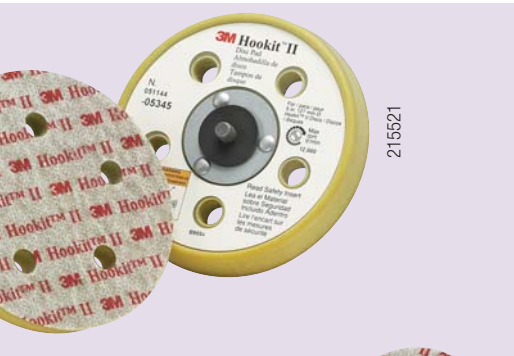

215521

3M™ Hookit™ II Dust-Free Low Profile Finishing Disc Pad

Specially designed for use with 3M Hookit II Dust-Free Discs. Has a soft foam construction for conformability and improved surface finish on sanded parts. Use with grade 220 and finer abrasive discs.

Size Dia x Thickness	Description	Part #	UPC	Max RPM	Max OPM	Qty/Case
5/16"–24 EXT						
5" x 11/16"	—	05345	051131-05345-8	12,000	12,000	10



213785

3M™ Hookit™ II Soft Interface Disc Pad

For use with 5" and 6" 3M Hookit II Discs. Constructed of a soft durable foam. When used with a standard Hookit II Backup Pad it increases conformability, allowing the technician to follow contours and get in closer to most edges.

Size Dia x Thickness	Description	Part #	UPC	Qty/Case
3" x NH	—	05271	051131-05271-0	10
5" x 1/2" x 1"	5 Dust Holes	05273	051131-05273-4	10
6" x 1/2" x 1"	6 Dust Holes	05274	051131-05274-1	10

3M™ Conversion Face

A conversion face that converts an existing pad to a 3M™ Hookit™ II Disc Pad. This accessory can be used for applications where the existing disc pad accessories are designed for the original 3M™ Hookit™ or Stikit™ Discs and the abrasive disc is a 3M Hookit II Disc.

Size Diameter	Converts	Part #	UPC	Max RPM	Max OPM	Qty/Case
3"	Hookit to Hookit II	02322	051131-02322-2	15,000	15,000	10
3" x NH*	Stikit to Hookit II	60529	051111-60529-5	—	—	2,500
5" x NH	Hookit to Hookit II	02327	051111-51074-2	12,000	12,000	10
	Stikit to Hookit II	02331	051111-51072-8	12,000	—	10
6" x NH	Hookit to Hookit II	02329	051111-51073-5	12,000	—	10
	Stikit to Hookit II	02333	051111-51071-1	12,000	—	10
5" x 5 Holes	Hookit to Hookit II	02328	051111-51070-4	12,000	—	10

* Made to order only.



85296



149040



85295

Note: The red printing on Hookit™ II faces is being discontinued. All Hookit II faces will be plain white.

3M™ Disc Pad Holder (Hook-and-Loop)

For use with surface conditioning discs.

For Random Orbital Sanders (5/16"–24 EXT)

Size Dia x Thickness	Hook Type*	Part #	UPC	Max RPM	Max OPM	Qty/ Case
5" x 1/4"	7	905	048011-09448-9	10,000	12,000	1
	5	905FD	048011-24282-8	10,000	12,000	1
6" x 1/4"	7	906	048011-09449-6	8,500	10,000	1

* See chart on page 7 for descriptions and photos of hook types.

For Right Angle Tools

Size Dia x Thickness	Hook Type*	Part #	UPC	Max RPM	Qty/ Case
1/4" Shank					
1-1/2"	5	9215	048011-04130-8	25,000	10
2"	5	922	048011-07494-8	23,000	10
	5	922	048011-18607-8	23,000	725
2" x 1/8"	7	922FV	048011-24230-9	23,000	10
3"	5	923	048011-04132-2	20,000	10
4"	5	924	048011-07492-4	13,000	5
1/2"–13 INT					
4" x 1/8" x 3/8"	7	914	048011-05673-9	13,000	1
4-1/2" x 1/8" x 3/8"	7	9145	048011-14110-7	13,000	1
5" x 1/8" x 3/8"	7	915	048011-05679-1	10,000	1
5/8"–11 INT					
4" x 1/8" x 3/8"	7	914	048011-05674-6	13,000	1
4-1/2" x 1/8" x 3/8"	7	9145	048011-14111-4	13,000	1
	5	9145FD	048011-32994-9	13,000	5
5" x 1/8" x 3/8"	7	915	048011-05680-7	10,000	1
6" x 1/8" x 3/8"	5	915FD	048011-32991-8	10,000	5
	7	916	048011-05682-1	10,000	1
7" x 5/16" x 3/8"	7	917	048011-09450-2	6,000	1
8" x 3/8"	5	917FD	048011-32988-8	6,000	5
	7	918V	048011-24229-3	6,000	1
8" x 5/16" x 3/8"	7	918	048011-09451-9	6,000	1
M14–2.0 INT					
4" x 1/8" x 3/8"	7	914	048011-05677-7	13,000	1
	5	914FD	048011-32996-3	13,000	5
4-1/2" x 1/8" x 3/8"	7	9145	048011-14114-5	13,000	1
5" x 1/8" x 3/8"	7	915	048011-05681-4	10,000	1
	5	915FD	048011-32990-1	10,000	5

* See chart on page 7 for descriptions and photos of hook types.



51713

External Threaded



95288

Internal Threaded



14470

1/4" Shaft

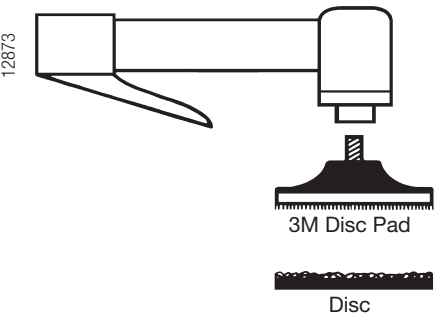

12873

3M Disc Pad

Disc



352091

3M™ Flange Adaptor

This flange is used to mount 6" Scotch-Brite™ Radial Bristle Discs onto bench motors with a shaft size of 1" diameter. Can be used on shaft sizes down to 1/2" diameter.

Size	Part #	UPC	Qty/ Inner	Qty/ Case
2" x 1"	27628	048011-27628-1	1	25



352090

3M™ Tapered Spindle Mount Adaptor

Accessory for 2" and 3" Scotch-Brite™ Radial Bristle Discs. Discs mount on this adaptor and adaptor fits on standard tapered spindle for bench motors.

Part #	UPC	Qty/ Case
30133	048011-30133-4	50



352097

3M™ Brush Extendor Adaptor

Adaptor designed to increase the width of the standard 8" Scotch-Brite™ Radial Bristle Brushes.

Size	Description	Part #	UPC	Qty/ Inner	Qty/ Case
3" x 3/4" x 1-1/4"	For use with 8" brushes	33092	048011-33092-1	1	10



352093

3M™ Flange Set

Set of flanges used to hold together and mount 8" Scotch-Brite™ Radial Bristle Discs. Normally, 14 discs are assembled on the flange set to create a 1" brush. This flange set comes standard when buying a Scotch-Brite radial bristle brush.

Size	Part #	UPC	Qty/ Inner	Qty/ Case
3" x 1-1/4"	33093	048011-33093-8	1	5

3M™ Mandrel

For use with 3/4", 9/16" and 1" Scotch-Brite™ Radial Bristle Discs or coated abrasive overlap slotted discs.

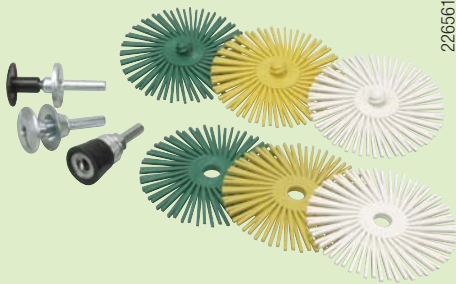

226561

Size (Shaft Dia x CH)	Part #	UPC	Max RPM	Qty/ Inner	Qty/ Case
For 3/4" or 9/16" Bristle Discs					
3/32" x 1/16"	27680	048011-27680-9	30,000	5	100
1/8" x 1/16"	27682	048011-27682-3	30,000	5	100
1/4" x 1/16"	27683	048011-27683-0	30,000	5	100
For 1" Bristle Discs					
1/8" x 1/8"	27681	048011-27681-6	30,000	5	100
1/4" x 1/8"	27684	048011-27684-7	30,000	5	100

3M™ SR Cutter Adaptor

Rotary cutter adaptor 1/4"—28 INT x 9/32"—40 EXT.

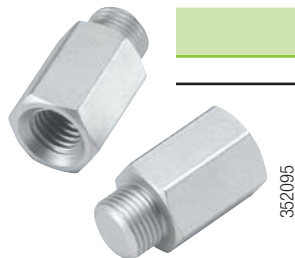

352095

Part #	UPC	Qty/ Case
33079	048011-33079-2	10

3M™ Roloc™+ Button

These buttons thread into the 3M Roloc+ Holder No. 1 for use with unitized wheels. They offer front-loading feature to allow for quick and easy wheel change.

Size	Description	Color	Part #	UPC	Max RPM	Qty/Case
3/8" CH	For 1-1/2" to 3" wheels x 1/8" wide	Blue	6	048011-15059-8	25,000	5
	For 1-1/2" to 3" wheels x 1/4" wide	Red	7	048011-15060-4	25,000	5

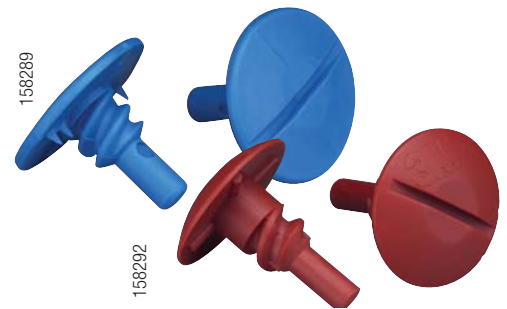

3M™ Roloc™+ Button Combination Pack

Pack contains one 3M Roloc+ Holder No. 1, 3M Roloc+ Button No. 7, and 1/4" shank. Use with 3" diameter and smaller x 1/4" wide x 3/8" center hole Unitized Wheels.

Size	Part #	UPC	Qty/Case
1/4" Shank	1 and 7	048011-14915-8	5

3M™ Wheel Adaptor No. 81A

For use with Type 81 and Type 84 PG Wheels. This adaptor has a 1/4" diameter shank and a 1/4"-20 thread female acceptor end.

Size	Part #	UPC	Qty/Inner	Qty/Case
1/4"	45081	051144-45081-7	1	1

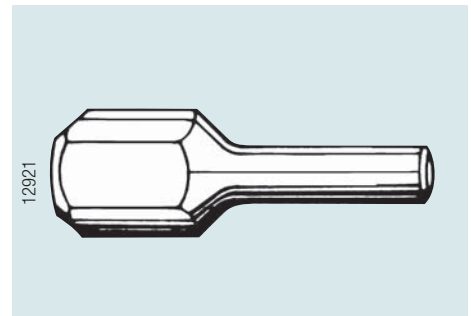

3M™ Wheel Adaptor Kit No. 2

For 3-1/2" or 4" PG Wheels. Adaptor includes spindle extension, 2 screws and 1 sleeve to accommodate wheels 1", 1-1/2", and 2" wide.

Size	Part #	UPC	Qty/Inner	Qty/Case
5/8"-11 INT	45040	051144-45040-4	1	1



3M™ Wheel Adaptor Kit No. 3

For all wheel widths up to and including 3" for wheels with 5"-8" diameters. Kit includes spindle extension for use on short spindles, 4 spacers, 1 arbor hole adaptor and 1 cap nut.

Size	Part #	UPC	Qty/Inner	Qty/Case
5/8"-11 EXT	45038	051144-45038-1	1	1



3M™ Flange Adaptor Kit No. 3

Used to reduce 1" internal diameter core size, flange size or wheel size to fit shafts smaller than 1" diameter. Fits 5"-8" diameter PG Wheels. This item is a stamped and formed sheet metal product.

Size	Part #	UPC	Qty/Inner	Qty/Case
1/2"	45035	051144-45035-0	1	1
5/8"	45034	051144-45034-3	1	1
3/4"	45033	051144-45033-6	1	1
7/8"	45032	051144-45032-9	1	1





51738

3M™ Flange Adaptor No. 5

Telescoping wheel adaptors 1" and 1/2" wide to reduce 1" wheel center holes to fit 1/2", 5/8", 3/4", or 7/8" shafts. Use with a set of flat or cupped washers 1/3 the diameter of the wheel for side support.

Size	Part #	UPC	Qty/Inner	Qty/Case
1-1/4" x 1" x 5/8"	5	048011-33248-2	5	5
1" x 1" x 1/2"	5	048011-16860-9	—	1
1" x 1/2" x 1/2"	5	048011-16859-3	—	1
1" x 5/8" x 1/2"	5	048011-30000-9	5	50



51726

3M™ Flange No. 356

Used to reduce wheel cores and internal diameters to fit smaller shaft sizes. This product spans a range of sizes. It is manufactured of spun aluminum and has a taper locking feature to automatically center the flange inside the core of the wheel.

Size	Part #	UPC	Qty/Case
10" x 1-3/4"	356	048011-03913-8	1 pair



354210

3M™ Flange No. 400

Use with 5.75" CH steel core brushes where center holes larger than 4" including keyways are required. These flanges are available with unbored, or rough cast, center holes 1-3/4" or 2-3/16". If a rough cast center hole is selected, the hole should be at least 1/8" smaller than the diameter of the machine shaft.

Size	Description	Part #	UPC	Qty/Case
5.75" x AH	Unventilated	400U	048011-91139-7	1 pair
	Ventilated	400V	048011-91140-3	1 pair

Note: Specify AH and keyway size when placing order.

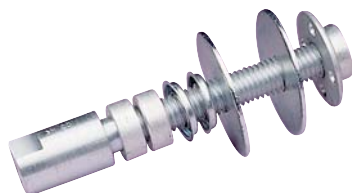

14375

3M™ Spindle Extendor Kit No. 300

For use on flexible shafts with Scotch-Brite™ Wheels 6" or 8" diameter, up to 4" in width. The kit contains (1) driving spindle 5/8" – 11 INT, (1) washer with 5/8" arbor hole, (2) bushings 1" x 5/8", (1) flange adaptor 5/8", (1) spanner nut (1/2" – 13 INT shank available by special request).

Part #	UPC	Qty/Case
300	048011-04019-6	1

3M™ Mandrels No. 931, 932 and 933

Used with unitized wheels. **Note:** 5/16" center hole is recommended for wheel 6 density or harder.

Size Length x Shank Size x Max Dia	Max Wheel Width	Part #	UPC	Washer RPM	Qty/ Case
1-1/2" x 1/8" x 1/2"	1/4"	931	048011-13966-1	13,000	5
2" x 1/4" x 3/16"	1/2"	932	048011-13967-8	20,000	5
2" x 1/4" x 1"	1"	933	048011-13968-5	14,000	5

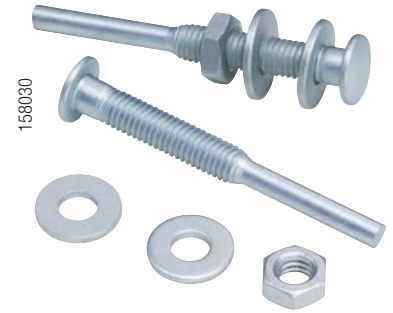

3M™ Mandrel No. 934

Used with unitized wheels 3"-6" diameter x 1/4", 1/2", 3/4", 1" wide x 1/2" center hole.

Size Length x Shank Size x Max Dia	Part #	UPC	Qty/ Case
3/16" x 1/4" x 2-1/2"	934	048011-04021-9	1

12,000 maximum RPM when used with a 3" outer diameter wheel.
8,500 maximum RPM when used with a 4" outer diameter wheel.
6,000 maximum RPM when used with a 6" outer diameter wheel.

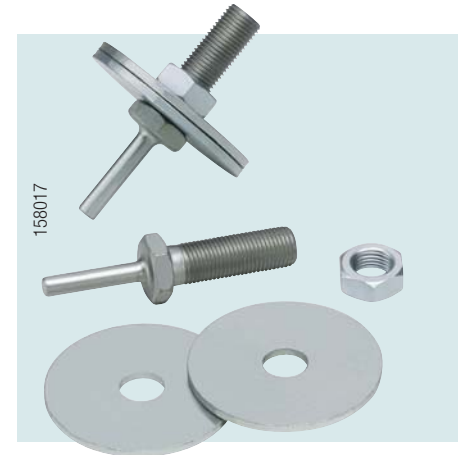

3M™ Mandrel No. 936

Use with unitized wheels 1" diameter x 1" wide x 3/16" center hole. 3M Mandrel No. 936 (plastic mandrel) self taps into the wheel.

Size Length x Shank Size x Max Dia	Part #	UPC	Max RPM	Qty/ Case
2-1/16" x 1/4" x 3/4"	936	048011-04018-9	22,200	5

3M™ Mandrel No. 990

Use with unitized wheels 2"-3" diameter x 1/8"-1/2" wide x 3/8" center hole. Use where high speed or easy loading is required. This mandrel comes with one silver cap for 1/8" and 1/4" wide wheels and one black cap for 3/8" and 1/2" wide wheels.

Size Length x Shank Size	Part #	UPC	Qty/ Case
1-3/4" x 1/4"	990	048011-15012-3	5

25,100 maximum RPM when used with a 2" outer diameter wheel.
22,200 maximum RPM when used with a 2-1/2" outer diameter wheel.
18,000 maximum RPM when used with a 3" outer diameter wheel.



3M™ Wide Brush and Wheel Dressing Material

Aluminum oxide, grade 36, resin-bonded mineral with an adhesive-backing used to dress Scotch-Brite™ Wide Brushes and Wheels.

Size	Part #	UPC	Qty/ Case
18" x 72"	WBWD	048011-04031-8	1



3M™ Wheel Dressing and Shaping Tape 80

Grade 80 conformable shaping tape used to final dress wheels and finely shape contours into wheels.

Size	Part #	UPC	Qty/ Case
2" x 50 yd	80	048011-30201-0	1

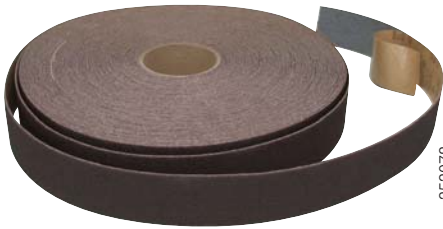

353078

3M™ Resin Bond Cloth PSA #40

Dress wheels and rough shape contours into wheels where more conformability is required.

Size	Part #	UPC	Qty/Case
2" x 50 yd	40	048011-08909-6	1

3M™ RX Hub

RX hubs are an aluminum extrusion with evenly spaced slots around the perimeter. Please specify arbor hole size when ordering so the proper stamped metal flanges can be provided to fit the hub to the machine. **Note:** These hubs are made to order. Order with generic UPC 051135-92689-5.

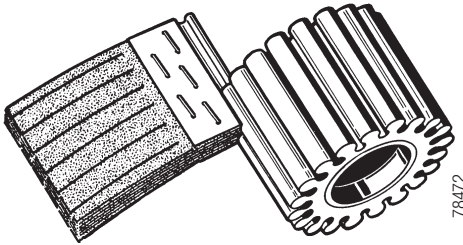

78472

Size	Slots/Hub	Part #	Qty/Case
3" x 1"	15	29501	1
3" x 2"	15	29502	1
3" x 3"	15	29503	1
3" x 4"	15	29504	1
3" x 5"	15	29505	1
3" x 6"	15	29506	1
3" x 7"	15	29507	1
3" x 8"	15	29508	1
3" x 9"	15	29509	1
3" x 10"	15	29510	1
3" x 11"	15	29511	1
3" x 12"	15	29512	1
4" x 1"	20	29513	1
4" x 2"	20	29514	1
4" x 3"	20	29515	1
4" x 4"	20	29516	1
4" x 5"	20	29517	1
4" x 6"	20	29518	1
4" x 7"	20	29519	1
4" x 8"	20	29520	1
4" x 9"	20	29521	1
4" x 10"	20	29522	1
4" x 11"	20	29523	1
4" x 12"	20	29524	1
6" x 1"	30	29525	1
6" x 2"	30	29526	1
6" x 3"	30	29527	1
6" x 4"	30	29528	1
6" x 5"	30	29529	1
6" x 6"	30	29530	1
6" x 7"	30	29531	1
6" x 8"	30	29532	1
6" x 9"	30	29533	1
6" x 10"	30	29534	1
6" x 11"	30	29535	1
6" x 12"	30	29536	1

3M™ RX Hub – Continued

Size	Slots/ Hub	Part #	Qty/ Case
8" x 1"	40	29537	1
8" x 2"	40	29538	1
8" x 3"	40	29539	1
8" x 4"	40	29540	1
8" x 5"	40	29541	1
8" x 6"	40	29542	1
8" x 7"	40	29543	1
8" x 8"	40	29544	1
8" x 9"	40	29545	1
8" x 10"	40	29546	1
8" x 11"	40	29547	1
8" x 12"	40	29548	1
10" x 1"	50	29549	1
10" x 2"	50	29550	1
10" x 3"	50	29551	1
10" x 4"	50	29552	1
10" x 5"	50	29553	1
10" x 6"	50	29554	1
10" x 7"	50	29555	1
10" x 8"	50	29556	1
10" x 9"	50	29557	1
10" x 10"	50	29558	1
10" x 11"	50	29559	1
10" x 12"	50	29560	1



3M™ Rubber Cushion Polishing Wheel

Available in a wide variety of sizes for use with 3M™ Bands and Belts. A mechanically expandable rubber cushion keeps the band or belt from slipping during use. UPC numbers apply to complete rubber cushion polishing wheels (1/4" diameter shank, nut and rubber cushion).

Size Dia x Width	Shank	Part #	UPC	Max RPM	Qty/Case
1/4" x 1/4"	1/4"	29700	051135-92688-8*	30,000	1
1/4" x 1/2"	1/8"	45159	051144-45159-3	23,000	1
3/8" x 1"	1/4"	29754	051135-92688-8*	30,000	1
	1/8"	29755	051135-92688-8*	30,000	1
1/2" x 1/2"	1/8"	29701	051135-92688-8*	30,000	1
	1/4"	45156	051144-45156-2	30,000	1
1/2" x 1"	1/4"	45153	051144-45153-1	15,000	1
1/2" x 1-1/2"	1/4"	45152	051144-45152-4	15,000	1
1/2" x 2"	1/4"	29702	051135-92688-8*	30,000	1
3/4" x 1/2"	1/4"	45148	051144-45148-7*	30,000	1
3/4" x 3/4"	1/4"	45146	051144-45146-3	24,000	1
	1/8"	45147	051135-92688-8*	15,000	1
3/4" x 1"	1/4"	45145	051144-45145-6	17,000	1
3/4" x 1-1/2"	1/4"	45144	051144-45144-9	10,000	1
3/4" x 2"	1/4"	29703	051135-92688-8*	20,000	1
1" x 3/4"	1/4"	29704	051135-92688-8*	19,000	1
1" x 1"	1/4"	45139	051144-45139-5	18,000	1
1" x 1-1/2"	1/4"	45138	051144-45138-8*	10,000	1
1" x 2"	1/4"	45137	051144-45137-1	8,000	1
1-1/2" x 3/4"	1/4"	29705	051135-92688-8*	16,000	1
1-1/2" x 1"	1/4"	45132	051144-45132-6	14,000	1
1-1/2" x 1-1/2"	1/4"	45131	051144-45131-9	10,000	1
1-1/2" x 2"	1/4"	45130	051144-45130-2	8,000	1
1-3/4" x 2"	1/4"	29706	051135-92688-8*	13,000	1
2" x 1"	1/4"	45129	051144-45129-6	11,000	1
2" x 2"	1/4"	45127	051144-45127-2	6,000	1
2" x 3"	1/2"	29707	051135-92688-8*	6,000	1
2" x 4"	1/2"	29708	051135-92688-8*	6,000	1
	3/8"	29746	051135-92688-8*	3,000	1
3" x 1"	1/2"	29750	051135-92688-8*	3,000	1
	3/8" - 16 INT	29710	051135-92688-8*	3,000	1
	3/8" - 24 INT	29714	051135-92688-8*	3,000	1
	7/16" - 14 INT	29718	051135-92688-8*	3,000	1
	1/2" - 13 INT	29722	051135-92688-8*	3,000	1
	1/2" - 20 INT	29726	051135-92688-8*	3,000	1
	5/8" - 11 INT	29730	051135-92688-8*	3,000	1
	5/8" - 18 INT	29734	051135-92688-8*	3,000	1
	3/4" - 10 INT	29738	051135-92688-8*	3,000	1
	3/4" - 16 INT	29742	051135-92688-8*	3,000	1
3" x 1-1/2"	3/8"	29747	051135-92688-8*	3,000	1
	1/2"	29751	051135-92688-8*	3,000	1
	3/8" - 16 INT	29711	051135-92688-8*	3,000	1
	3/8" - 24 INT	29715	051135-92688-8*	3,000	1
	7/16" - 14 INT	29719	051135-92688-8*	3,000	1
	1/2" - 13 INT	29723	051135-92688-8*	3,000	1
	1/2" - 20 INT	29727	051135-92688-8*	3,000	1
	5/8" - 11 INT	29731	051135-92688-8*	3,000	1
	5/8" - 18 INT	29735	051135-92688-8*	3,000	1
	3/4" - 10 INT	29739	051135-92688-8*	3,000	1
3/4" - 16 INT	29743	051135-92688-8*	3,000	1	

*Made to order.

3M™ Rubber Cushion Polishing Wheel – Continued

Size Dia x Width	Shank	Part #	UPC	Max RPM	Qty/Case	
3" x 2"	3/8"	29748	051135-92688-8*	3,000	1	
	1/2"	29752	051135-92688-8*	3,000	1	
	3/8"–16 INT	29712	051135-92688-8*	3,000	1	
	3/8"–24 INT	29716	051135-92688-8*	3,000	1	
	7/16"–14 INT	29720	051135-92688-8*	3,000	1	
	1/2"–13 INT	29724	051135-92688-8*	3,000	1	
	1/2"–20 INT	29728	051135-92688-8*	3,000	1	
	5/8"–11 INT	29732	051135-92688-8*	3,000	1	
	5/8"–18 INT	29736	051135-92688-8*	3,000	1	
	3/4"–10 INT	29740	051135-92688-8*	3,000	1	
	3/4"–16 INT	29744	051135-92688-8*	3,000	1	
	3" x 3"	3/8"	45124	051144-45124-1	3,000	1
		1/2"	45123	051144-45123-4	3,000	1
		3/8"–16 INT	29713	051135-92688-8*	3,000	1
3/8"–24 INT		29717	051135-92688-8*	3,000	1	
7/16"–14 INT		29721	051135-92688-8*	3,000	1	
1/2"–13 INT		29725	051135-92688-8*	3,000	1	
1/2"–20 INT		29729	051135-92688-8*	3,000	1	
5/8"–11 INT		29733	051135-92688-8*	3,000	1	
5/8"–18 INT		29737	051135-92688-8*	3,000	1	
3/4"–10 INT		29741	051135-92688-8*	3,000	1	
3/4"–16 INT	29745	051135-92688-8*	3,000	1		

*Made to order.

3M™ Rubber Expander Wheel

For use with 3M™ Bands or Belts. Slotted rubber drum expands with centrifugal force to keep the band tight while grinding. 1/4" diameter shank.

Size Dia x Width	Shank	Part #	UPC	Max RPM	Qty/Case
1" x 1"	1/4" Dia.	77717	051144-77717-4	18,000	1
1-1/2" x 1"	1/4" Dia.	77718	051144-77718-1	14,000	1
2" x 1"	1/4" Dia.	77720	051144-77720-4	12,000	1
2" x 2"	1/4" Dia.	77721	051144-77721-1	6,000	1
3" x 3"	5/8"–11 INT	77722	051144-77722-8	6,000	10



3M™ Scotchlite™ Platen Pad Cover

Pressure Sensitive Adhesive (PSA) backing.

Size	Part #	UPC	Qty/Case
10-1/2" X 53"	06541	051111-56599-5	1



211438

3M™ Screen Cloth Disc Hand Pad

Use with screen cloth discs with 2-tabs.

Size Dia x Thickness	Die #	Part #	UPC	Qty/ Inner	Qty/ Case
5" x 1"	500 GC	02712	051111-55845-4	—	10
6" x 1"	600 JR	99736	051111-60788-6	—	10
8" x 1"	800 JM	02713	051111-55846-1	—	10
8" x 1"	800 JM	82793	051144-82793-0	10	40



211412

3M™ Stikit™ Hand Pad

For use with all grades of 3M™ Stikit™ Discs, these pads are firm yet conformable and lightweight. Makes corner and contour sanding easier.

Size Dia x Thickness	Part #	UPC	Qty/ Inner	Qty/ Case
5"	05585	051144-05585-2	1	10
6"	05586	051144-05586-9	1	10



211422

3M™ Stikit™ Soft Hand Pad

For use with 3M™ Stikit™ Sheet Rolls and Sanding Paper Sheets. This pad provides a soft controlled touch. Eliminates finger marks and edge cutting into primer and paint. Ideal for contour and light scuff sanding.

Size W X L x Thickness	Part #	UPC	Qty/ Inner	Qty/ Case
2-3/4" x 5-1/2" x 3/8"	05530	051144-05530-2	5	50

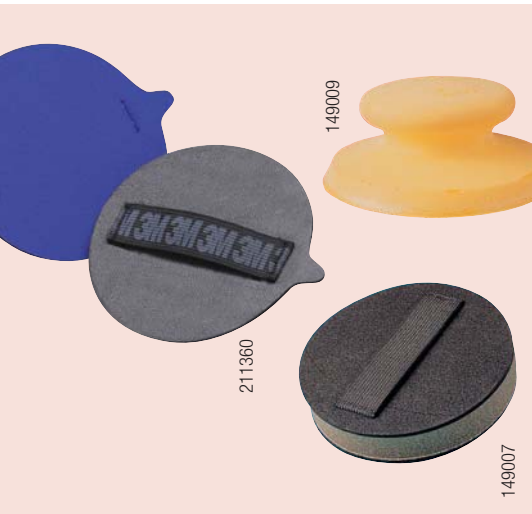

149009

211360

149007

3M™ Stikit™ Disc Hand Pad

Hand sanding of wood and metal is easy with 3M Stikit Discs and Disc Hand Pads. Designed to securely hold the disc, but allow easy removal.

Size Dia x Thickness	Description	Part #	UPC	Qty/ Inner	Qty/ Case
5"	Molded — Blue Vinyl Face	88742	051144-88742-2	10	10
5" x 1/8"	Blue Cloth Face	45188	051144-45188-3	—	20
5" x 1/4"	Blue Cloth Face	45189	051144-45189-0	—	20
5" x 3/8"	Blue Cloth Face; Half Round	06624	051111-56462-2	1	20
5" x 1"	Rubber Face	11063	051144-11063-6	1	10
5" x 1"	Blue Cloth Face	84229	051144-84229-2	10	10
6" x 1"	Rubber Face	05589	051131-05589-6	10	40
6" x 1/4"	Blue Cloth Face	05591	051131-05591-9	1	20
6" x 1/8"	Blue Cloth Face	45198	051144-45198-2	—	20



158145



3M™ Sanding Block

A pliable rubber block which holds sandpaper securely during wet or dry sanding operations.

Size Width x Length	Description	Part #	UPC	Qty/ Inner	Qty/ Case
2-3/4" x 5"	Uses 2-3/4" sheets	05519	051144-05519-7	1	10
3" x 8"	Uses 3" x 11" cut sheets (1/3 of a 9" x 11" sheet)	05520	051131-05520-9	1	10

3M™ Hookit™ Disc Hand Pad

Excellent tool for hand sanding with A-weight or C-weight 3M Hookit Discs.

Size Dia x Thickness	Description	Hook Type*	Part #	UPC	Qty/ Inner	Qty/ Case
3"	Firm Contoured Molded	1	01908	051111-55766-2	10	10
5"	Molded	1	85095	051144-85095-2	10	10
5" x 1/4"	—	1	77752	051144-77752-5	—	20
	Half Round	1	88132	051111-56493-6	1	20
5" x 1"	—	1	77750	051144-77750-1	10	10
6" x 1/4"	—	1	05791	051131-05791-3	1	20
	Half Round	1	05792	051131-05792-0	1	20

* See chart on page 7 for descriptions and photos of hook types.

3M™ Hookit™ II Disc Hand Pad

Excellent tool for hand sanding with 3M Hookit II Discs.

Size Dia x Thickness	Description	Part #	UPC	Qty/ Inner	Qty/ Case
5"	Molded	85088	051144-85088-4	10	10
5" X 1"	Hand Pad	85089	051144-85089-1	10	10
5" X 1/4"	Hand Pad	02002	051111-56498-1	1	20
6" X 1/4"	Hand Pad	05291	051131-05291-8	1	20
	Half Round	05292	051131-05292-5	1	20



3M™ Center Water Feed (CWF) Disc Hand Pad

This patented pad supplies water to the job and dispenses the proper amount of water for wet sanding of plastics, primer surface, paint, fiberglass, etc. The water flushes the sanding residue off the sanding disc which keeps the disc from loading. Available in 3M™ Stikit™, 3M™ Hookit™ and 3M™ Hookit™ II Attachment Systems.

Size	Attachment System	Hook Type*	Part #	UPC	Qty/ Inner	Qty/ Case
2" x 5/8"	Hookit	1	88741	051144-88741-5	10	10
	Stikit— Soft Bullet Shape	—	77749	051144-77749-5	10	10
	Stikit— Firm Bullet Shape	—	82705	051144-82705-3	10	10
	Hookit— Bullet Shape	1	82457	051144-82457-1	10	10
3" x 7/8"	Hookit— Contoured Firm	1	70147	051111-56445-5	—	10
	Hookit II— Contoured	—	85087	051144-85087-7	10	10
	Hookit II— Bullet Shape	—	70384	051111-56496-7	10	10
	Stikit	—	45220	051144-45220-0	1	10
5" x 1-3/8"	Hookit	1	82456	051144-82456-4	10	10

* See chart on page 7 for descriptions and photos of hook types.



3M™ Center Water Feed (CWF) Disc Hand Pad Replacement Sponge

Size	Part #	UPC	Qty/ Inner	Qty/ Case
7/8"	82191	051144-82191-4	10	100

Note: The red printing on Hookit™ II faces is being discontinued. All Hookit II faces will be plain white.



158144

3M™ Wetordry™ Sponge Pad No. 20

A firm hand sanding pad to be used with a three-fold wrap of 3M™ Paper Sheets or 3M™ Wetordry™ Sheets to make hand sanding easier and more efficient.

Size	Part #	UPC	Qty/ Inner	Qty/ Case
2-3/4" x 5-1/2" x 3/8"	05526	051131-05526-1	5	50

3M™ Stikit™ Hand Block

Made of a sturdy, durable, high strength plastic, this block has an embossed rubber face which allows good adhesion for Stikit Sheet Rolls and Stikit Sheets.

Size	Part #	UPC	Qty/ Inner	Qty/ Case
2-3/4" x 5"	05440	051144-05440-4	1	10
2-3/4" x 7-3/4"	05441	051144-05441-1	1	10



149010



93404

3M™ Stikit™ Soft Hand Block

Made of a tough flexible foam which allows the user to block sand on flat surfaces or contours. Stikit Sheets adhere firmly to its vinyl face.

Size	Part #	UPC	Qty/ Inner	Qty/ Case
2-3/4" x 5"	05442	051144-05442-8	1	10



85365

3M™ Stikit™ Sanding Block

Handy Stikit Sanding Blocks carry their own abrasive supply. Sand corners with flat end. Sand contours with rounded end. For fresh abrasive, lift sandpaper, pull from feed roll, press to cushioned backup pad then tear off used Stikit Paper.

Size	Part #	UPC	Qty/ Inner	Qty/ Case
2-1/2"	45203	051144-45203-3	6	6
3-1/4"	45204	051144-45204-0	6	6



211420



3M™ Stikit™ Hand File Board

Features a sturdy design that provides a non-twisting, flat sanding surface. This file board has an embossed rubber face that allows good adhesion release when used with 3M Stikit Sheets.

Size	Part #	UPC	Qty/ Inner	Qty/ Case
2-3/4" x 16"	05444	051144-05444-2	1	1



211436

3M™ Hookit™ Hand Block

Firm plastic block with easy release hook face. Use with 3M Hookit abrasives sheets for leveling of repair area.

Size	Hook Type*	Part #	UPC	Qty/ Inner	Qty/ Case
2-3/4" x 5"	1	05740	051131-05740-1	—	10
2-3/4" x 7-3/4"	1	05741	051131-05741-8	—	10
2-3/4" x 5"	2	81915	051144-81915-7	1	10

* See chart on page 7 for descriptions and photos of hook types.

3M™ Hookit™ Soft Hand Block

Soft molded foam block with easy release hook face. Use with 3M Hookit abrasives sheets 2-3/4" x 5" for leveling of repair area or following contours.

Size	Hook Type*	Part #	UPC	Qty/Case
2-3/4" x 5"	1	05742	051131-05742-5	10
2-3/4" x 5"	2	81322	051144-81322-3	10

* See chart on page 7 for descriptions and photos of hook types.

3M™ Wooden Hand Block

Hook material laminated to the face of the wooden hand block makes grade changes easy. For use with Flexible Diamond QRS sheets.

Size	Hook Type*	Part #	UPC	Qty/Inner	Qty/Case
2-1/4" x 5"	2	81108	051144-81108-3	1	1

* See chart on page 7 for descriptions and photos of hook types.

3M™ Hookit™ Hand File Board

Features a sturdy design that provides a non-twisting, flat sanding surface. Firm plastic block with easy release hook face. Use with 3M Hookit abrasives sheets for leveling of repair area.

Size	Hook Type*	Part #	UPC	Qty/Inner	Qty/Case
2-3/4" x 16"	1	05744	051131-05744-9	1	1

* See chart on page 7 for descriptions and photos of hook types.

3M™ Hookit™ Facing Roll

Allows conversion of self-made fairing boards to the Hookit attachment system to utilize 4-1/2" x 30" 3M Hookit abrasive sheets. Use 3M™ General Trim Adhesive (PN08088) for bonding 3M Hookit facing material.

Size	Hook Type*	Part #	UPC	Qty/Case
4-1/8" x 12'	1	88044	051111-50197-9	1

* See chart on page 7 for descriptions and photos of hook types.

3M™ Hookit™ II Hand Block

Firm plastic block with easy release loop face. Use with 3M Hookit II abrasives sheets for leveling of repair area.

Size	Part #	UPC	Qty/Inner	Qty/Case
2-3/4" x 5"	05240	051131-05240-6	1	10
2-3/4" x 7-3/4"	05241	051131-05241-3	1	10

3M™ Hookit™ II Soft Hand Block

Made of a tough flexible foam which allows the user to block sand on flat surfaces or contours. Use with 2-3/4" x 5" 3M Hookit II Sheets.

Size	Part #	UPC	Qty/Inner	Qty/Case
2-3/4" x 5"	05242	051131-05242-0	1	10

3M™ Hookit™ II Hand File Board

Features a sturdy design that provides a non-twisting, flat sanding surface. Firm plastic block with easy release loop face. Use with 3M Hookit II abrasive sheets for leveling of repair area.

Size	Part #	UPC	Qty/Inner	Qty/Case
2-3/4" x 16"	05244	051131-05244-4	1	1

Note: The red printing on Hookit™ II faces is being discontinued. All Hookit II faces will be plain white.





51766

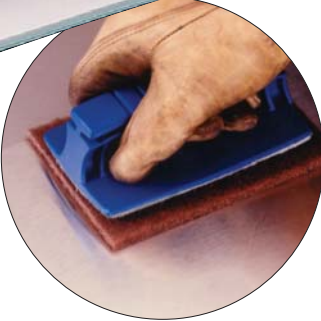

185792

3M™ Twist-Lok™ Pad Holder No. 961

Use with Scotch-Brite™ hand pads and roll material cut to 4" x 6". Specially designed for use with hand pads to make clean up jobs faster, easier and safer. Distributes pressure evenly over pad surface for efficient cleaning action and improved pad life.

Size	Part #	UPC	Qty/Case
3-1/2" x 4-3/4"	961	048011-09493-4	1

3M™ Insta-Lok™ Hand Block 952

Hand block with 3M Insta-Lok hook material to hold Scotch-Brite™ Hand Pads and roll material cut to 4" x 6".

Size	Part #	UPC	Qty/Case
3-3/8" x 5-3/4"	952	048011-04013-4	10

3M™ Doodlebug™ Pad Holder 250

Use with Scotch-Brite™ Hand Pads 4" x 10" in a chemical environment, particularly with aircraft cleaning pads. Holder has a swivel attachment which accepts a threaded broom handle. 250HD has heavy-duty holding for wet applications.

Size	Part #	UPC	Qty/Case
4" x 9-1/4"	250	048011-12929-7	5
3-3/4" x 9"	250HD	048011-33608-4	5

Scotch-Brite™ Conformable Applicator Cleaner Head 261

Flexible concave shaped hook-and-loop holder designed to be used with chemical cleaners. Use with 6" x 12" sheets. Holder has a swivel attachment which accepts a threaded broom handle.

Sheet Size	Hook Type*	Part #	UPC	Qty/Case
6" x 12"	2	261	048011-05717-0	1

* See chart on page 7 for descriptions and photos of hook types.



228359

DISPENSERS



149006



43113

3M™ Stikit™ Double Roll Dispenser

A portable, sturdy dispenser which holds two 3M Stikit Sheet Rolls for quick and easy dispensing. Keeps abrasive flat while protecting the adhesive backing.

Size Width	Part #	UPC	Qty/Inner	Qty/Case
2-3/4"	05452	051144-05452-7	1	1

3M™ Stikit™ Disc Roll Dispenser

These sturdy metal dispensers provide convenient means of storage and single disc dispensing of 5" or 6" 3M Stikit Disc Rolls. Dispenser can be wall or bench mounted as well as used portably. Double dispenser holds disc rolls with a 1" diameter core.

Size Diameter	Part #	UPC	Qty/Inner	Qty/Case
5" or 6"	05450	051144-05450-3	1	1

3M™ Square / Cross Pad Mandrel

Used for holding square pads and cross pads.

Size		Part #	UPC	Qty/ Inner	Qty/ Case
1/4"	8-32 EXT	14307	051144-14307-8	1	1
	1/4"-20 EXT	14308	051144-14308-5	1	1



3M™ Spindle and Mandrels

Cartridge Roll Diameter	MOS (Max Operating Speed)
1"	12,000
5/8" and 3/4"	16,000
1/2" and Smaller	24,000

Screw type mandrels and forked spindle, holders for cartridge rolls. Dimensions listed as pilot diameter, pilot length and shaft length unless otherwise noted.

Size	Part #	UPC	Qty/ Case
Mandrels			
1/4" x 1-1/2" x 1/4"	45116	051144-45116-6	25
1/8" x 1" x 1/4"	45119	051144-45119-7	25
3/16" x 1-1/2" x 1/4"	45118	051144-45118-0	25
3/16" x 1" x 1/4"	45117	051144-45117-3	25
3/32" x 3/4" x 1/4"	45120	051144-45120-3	25



Size	Part #	UPC	Qty/ Case
Forked Spindle			
3" x 1/16" x 3/4" x 1/4"	45121	051144-45121-0	10



3M™ Mini Mandrel No. 935

Use with 1" wide x 1-1/2" long sheets of Scotch-Brite™ Material to fit into tight areas.

Size Length x Shank	Part #	UPC	Max RPM	Qty/ Case
2-7/8" x 1/4"	935	048011-04020-2	14,000	5



3M™ Mandrel No. 944

Use with Scotch-Brite™ Stars with 1/4"-20 internal threads.

Size	Part #	UPC	Max RPM	Qty/ Case
1/4" shank with 1/4"-20 EXT	944	048011-13928-9	24,100	1



3M™ Stikit™ Air File Shoe

Designed for use on all straight air files and for use with 3M Stikit File Sheets. This air file shoe features a tuck-in clip on the leading edge for easy insertion and quick application on file sheets plus elimination of mechanical clips to make removal of the sheet easier.

Size	Part #	UPC	Qty/ Inner	Qty/ Case
2-3/4" x 16"	05448	051144-05448-0	1	5



3M™ Hookit™ Air File Shoe

The 3M Hookit Air File Shoe has been designed for use on all straight air files with 3M Hookit File Sheets. The 3M Hookit face allows easy attachment and removal of 3M Hookit Sheets while eliminating the need for mechanical clips.

Size	Hook Type*	Part #	UPC	Qty/ Inner	Qty/ Case
2-3/4" x 16"	1	05248	051131-05248-2	1	5

* See chart on page 7 for descriptions and photos of hook types.

3M™ Wetordry™ Rubber Squeegee

Made of flexible rubber in two sizes. The 3" x 2" size is used for removing slush created when sanding with water while the 2-3/4" x 4-1/2" size is used for applying glazing putty and plastic filler.

Size	Part #	UPC	Qty/ Inner	Qty/ Case
2-3/4" x 4-1/4"	05517	051144-05517-3	1	50
2" x 3"	05518	051144-05518-0	1	50



3M™ Dual Lock™ Tape, Type 400

Mechanical fasteners with Pressure Sensitive Adhesive (PSA) backing. Used to cover a cylinder with hooks to allow loop backed 3M™ Brushlon™ Products to be applied to the cylinder.

Size	Hook Type*	Part #	UPC	Qty/ Case
2" x 50 yd	6	SJ3551	051144-13662-9	1
Specify	6	SJ3443	051144-94388-3	1
Specify	6	SJ3551	051144-76135-7	1

* See chart on page 7 for descriptions and photos of hook types.

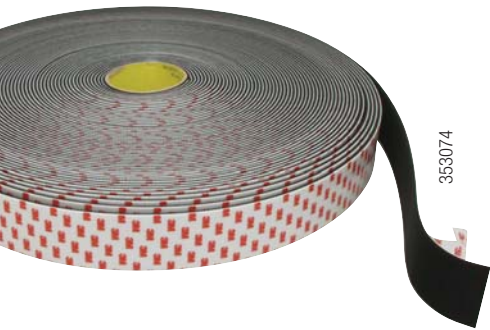

3M™ Paint Buster™ Hand Cleaner

Cream type hand cleaner offering superior performance in the removal of lacquer, enamel and urethane paints, primers, putties, plastic fillers, adhesives and automotive sealants from skin.

Size	Part #	UPC	Qty/ Case
10.5 fl.oz.	05975	051131-05975-7	12



3M™ Roto Peen Assembly Kit

A convenient kit containing a 3M Roto Peen Almen Strip Holder, two sizes of 3M Roto Peen Flap Assemblies TC-330, and 3M Roto Peen Mandrels 7210 and 7211.

Part #	UPC	Qty/ Case
9041	048011-17157-9	1

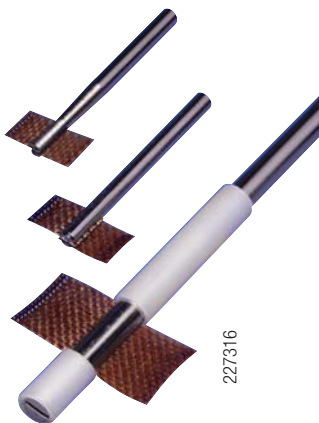

3M™ Heavy Duty Roto Peen Hub Assembly

Hub measures 4" diameter with a 2-1/2" ID and is furnished with flanges (5/8", 3/4", 1" or 1-1/4" ID). When ordering hub which requires flanges, specify a fourth dimension indicating the flange ID. Additional flanges can be ordered separately.

Size Dia x ID	Part #	UPC	Qty/ Case
4" x 2-1/2"	91136	048011-91136-6	1

3M™ Heavy Duty Roto Peen Spacer Ring

For use with hubs with widths ending in 1/4" (i.e. 4-1/4", 7-1/4", etc.). When used properly, this product eliminates streaking caused by improper flap staggering.

Size	Part #	UPC	Qty/ Inner	Qty/ Case
4"	18368	048011-18368-8	10	20
Long	2	048011-13901-2	—	2
Short	1	048011-13900-5	—	2

3M™ Roto Peen Mandrels 7210, 7211 and 7212

Use with 3M Roto Peen Flap assemblies.

Size Flap Assembly	Part #	UPC	Qty/ Case
9/16" X 1-1/4"	7210	048011-03768-4	1
1" X 2"	7211	048011-03767-7	1
9/16" X 1"	7212	048011-05969-3	1

3M™ Roto Peen Almen Strip Holder

Use to hold almen strips for testing peening intensity.

Size	Part #	UPC	Qty/ Case
2" x 7" x 1"	ALMEN	048011-03764-6	1

3M™ Fladder Blade Spacer Ring

Each fladder blade is placed on a styrofoam spacer which centers it and provides separation when it is placed on the machine spindle.

Size	Part #	UPC	Max RPM	Qty/ Case
32mm	13071	051144-13071-9	6,000	25
50mm	13070	051144-13070-2	6,000	25

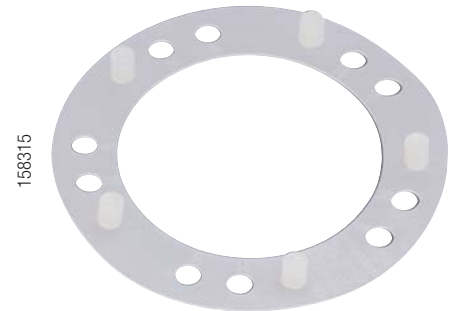

158315



227316



158040



158206



3M™ Finesse-it™ Hand Sanding Pad

Red rubber hand sanding pad can be used to hold Pressure Sensitive Adhesive (PSA) sanding discs. Removes dust and dirt nibs.

Size	Description	Part #	UPC	Qty/ Inner	Qty/ Case
	—	13441	051144-13441-0	10	20
1-1/4"	Soft — Black Vinyl Face	50199	051111-50199-3	10	20
	Soft Contoured — Vinyl Face	70437	051135-92499-0	5	20

3M™ Finesse-it™ Interface Disc Pad—Soft

Interface Disc Pad has Pressure Sensitive Adhesive (PSA) with liner on one side and vinyl on the other. Use with Finesse-it Hand Sanding Pads when added softness for conformability is desired. Helps reduce edge cuts.

Size	Color	Part #	UPC	Qty/ Case
1-1/8" x 1/8"	Black	70449	051111-56472-1	25

3M™ Finesse-it™ Disc Pad

For use if a sanding tool is preferred over hand sanding. This 1-1/4" diameter sanding pad can be used with tools equipped with a 1/4"—20 EXT threaded shank. This pad has a vinyl face for easy disc removal.

Size	Part #	UPC	Max RPM	Max OPM	Qty/ Inner	Qty/ Case
1-1/4" x 5/16" x 1/4"—20 INT	01962	051135-92502-7	6,000	10,000	10	20

3M™ Finesse-it™ Roloc™ Sanding Pad

For use if a sanding tool is preferred over hand sanding. The 3M Finesse-it Roloc Sanding Pad can be used with a 1" 3M Roloc Disc Pad or with tools equipped with the 3M Roloc attachment system.

Size	Description	Part #	UPC	Max RPM	Max OPM	Qty/ Inner	Qty/ Case
1-1/4"	Medium — Blue Vinyl Face	02345	051111-50198-6	10,000	10,000	10	20
	Firm — Blue Vinyl	02511	051111-51150-3	10,000	10,000	10	20
	Firm — Rubber Face	13442	051144-13442-7	6,000	10,000	10	100
	Soft — Rubber Face	82271	051144-82271-3	6,000	10,000	10	100
1-1/4" x 5/16"	Medium — Black Vinyl/Roloc TR	02727	051111-55833-1	10,000	—	20	10
2" x 5/16"	Medium — Blue Vinyl/Roloc TR	06613	051111-55834-8	10,000	—	20	5

3M™ Finesse-it™ Roloc™ Finishing Disc Pad

Pad is made with soft foam, 3M Roloc button and hook face. Use with 3" soft 3M Roloc Disc Pad. Holds the 3M Finesse-it Buffing Pads firmly in place. Soft foam provides good conformability.

Size	Hook Type*	Part #	UPC	Max RPM	Max OPM	Qty/ Inner	Qty/ Case
3"	3	14736	051144-14736-6	6,000	10,000	12	120
	1	14736V	051111-51168-8	6,000	10,000	12	120

* See chart on page 7 for descriptions and photos of hook types.

3M™ Finesse-it™ Sanding Pencil

For spot touch-up of small areas. Utilizes 5/8" x NH PSA discs.

Size	Part #	UPC	Qty/ Case
5/8"	14739	051144-14739-7	10



3M™ Finesse-it™ Buffing Pad

3M Finesse-it Buffing Pads provide a soft, smooth surface for use with 3M Finesse-it Finishing Material or 3M Finesse-it Final Finish.

Size	Description	Part #	UPC	Qty/Inner	Qty/Case
3"	White	05925	051131-05925-2	20	100
	Red & White	09357	134375-38287-8	50	500
	White	13446	051144-13446-5	60	600
3-1/4"	Orange Foam — White Loop	02648	051111-51151-0	10	50
	Orange Foam — Black Loop	02648B	051111-60527-1	10	50
3-3/4"	Orange Foam — White Loop	02637	051111-51158-9	10	50
5"	Red & White	09358	134375-38286-1	50	200
	White Foam	01912	051135-92500-3	10	50
5-1/4"	Orange Foam — White Loop	02362	051111-51076-6	10	50
	Orange Foam — Black Loop	02362B	051111-60528-8	10	50



3M™ Finesse-it™ Natural Buffing Pad

Made with specially selected lamb's wool hide. Pad has a 3M™ Hookit™ Attachment System. Designed for use with 3M™ Finesse-it Polishes.

Size	Description/Pile Height	Part #	UPC	Qty/Inner	Qty/Case
3"	20mm trim	81470	051144-81470-1	10	50
	Black; 22mm trim	85103	051144-85103-4	10	50
3" x 7/8" CH	For use with Ingersoll-Rand Cold Air Polishing System	82182	051144-82182-2	10	50
	Black; 22mm trim	70393	051111-55811-9	50	50
5-1/4"	20mm trim	81471	051144-81471-8	10	50
	Black; 22mm trim	85100	051144-85100-3	10	50
	Sorted for Centeredness	85101	051144-85101-0	10	50
7"	Use PN05717 Hookit SBS Backup Pad; 20mm trim	82531	051144-82531-8	10	10



3M™ Finesse-it™ Knit Buffing Pad

3M Finesse-it Buffing Pad is made from wool fibers for use with 3M Finesse-it Finishing Material or 3M Finesse-it Final Finish. Has a 3M™ Hookit™ Attachment System.

Size	Pile Height	Part #	UPC	Qty/Inner	Qty/Case
3"	15/16"	85078	051144-85078-5	10	50
5-1/4"	15/16"	85079	051144-85079-2	10	50





215513

3M™ Finesse-it™ Knit II Buffing Pad

3M Finesse-it Buffing Pad made from wool fibers for use with 3M Finesse-it Finishing Material or 3M Finesse-it Final Finish. The pad is pre-washed to reduce loose fibers. 3M™ Hookit™ Attachment System.

Size	Pile Height	Part #	UPC	Qty/ Inner	Qty/ Case
3"	11/16"	85099	051144-85099-0	10	50
3"	15/16"	85084	051144-85084-6	10	50
4"	15/16"	88737	051144-88737-8	10	50
5-1/4"	15/16"	85083	051144-85083-9	10	50



85321

3M™ Perfect-it™ Foam Compounding Pad

Foam compounding pads used to apply compounds to remove sand scratches and swirls. Features a waffles face design which holds compounds better (i.e., reduces slinging of compound). Has 3M™ Hookit™ Attachment System.

Size	Part #	UPC	Qty/ Inner	Qty/ Case
8"	05723	051131-05723-4	1	12



363082

3M™ Perfect-it™ III Wool Compounding Pad

Made with specially selected lamb's wool hide. Pad has a 3M™ Hookit™ attachment system. Designed for use with 3M™ Finesse-it™ Compounds or Perfect-it™ III Compounds

Size	Pile Height	Part #	UPC	Qty/ Inner	Qty/ Case
5-1/4"	20mm	01927	051111-51043-8	2	10



85215

211353

3M™ Perfect-it™ Hookit™ Foam Polishing Pad

Soft foam polishing pads used to apply polishes and glazes to remove haze and swirls. Features a waffle face design which holds polishes better (i.e., reduces slinging of polish).

Size	Part #	UPC	Qty/ Inner	Qty/ Case
3"	05726	051131-05726-5	10	40
5-1/4"	05727	051131-05727-2	12	48
8"	05725	051131-05725-8	2	12

3M™ Finesse-it™ Hookit™ Foam Buffing Pad

White foam pad. Use with 3M™ Finesse-it™ Trizact™ Paint Defect Repair System for best finish.

Size	Part #	UPC	Qty/ Inner	Qty/ Case
3"	01963	051111-60799-2	10	50

353081

3M™ Finesse-it™ Hookit™ Polishing Pad

Soft foam polishing pad used to apply polishes and glazes to remove haze and swirls. Has 3M™ Hookit™ Attachment System. Use with 5 inch diameter 3M Hookit Discs Pads.

Size	Part #	UPC	Qty/ Inner	Qty/ Case
5"	76848	051144-76848-6	25	100

86377

3M™ Finesse-it™ Contact Disc Pad

For use with 3M™ Finesse-it™ Buffing or Polishing Pads and 3M™ Hookit™ Abrasives. Ideal for large areas. Accommodates a 5/8"–11 EXT threaded shaft for use with rotary sanders.

Size	Part #	UPC	Max RPM	Qty/Inner	Qty/Case
5" x 1" x 5/8"–11 INT	14738	051144-14738-0	7,000	10	10



3M™ Superbuff™ Buffing Pad

3M Superbuff Buffing Pad has a unique double face construction for utilizing both sides of the pad. Its own lightweight, built-in support system eliminates heavy backup pads. Soft, usable edge allows you to get into hard-to-get-at areas. Edge burn is practically eliminated.

Size	Part #	UPC	Qty/Inner	Qty/Case
9"	05700	051144-05700-9	1	24



3M™ Superbuff™ 2 Plus 2 Buffing Pad

Has all the same features as the #5700 pad except that it is more flexible. 3M Superbuff 2 Plus 2 buffing pad gets into tight areas and reverse curves more easily. Use for compounding prior to glazing. This pad has a unique double face construction for utilizing both sides of the pad. Its own lightweight, built-in support system eliminates heavy backup pads. Use with 3M Superbuff Adaptor.

Size	Part #	UPC	Qty/Inner	Qty/Case
9"	05701	051144-05701-6	1	24

100475

3M™ Superbuff™ Polishing Pad

A double sided polishing pad designed for use with a polisher and glaze. The 3M Superbuff polishing pad is made with extremely fine fibers to produce a high gloss on paint surfaces. Pad has its own built-in support system. Use with 3M Superbuff Adaptor.

Size	Part #	UPC	Qty/Inner	Qty/Case
6"	05720	051144-05720-7	—	12
9"	05705	051144-05705-4	1	24



100482

3M™ Superbuff™ Adaptor

This adaptor has a 5/8"–11 internal thread which turns onto a polisher on one end and a short 5/8"–11 external thread on the other end. Used with 3M Superbuff Pads to keep the polisher shaft from hitting the car's paint finish.

Size	Part #	UPC	Qty/Inner	Qty/Case
5/8"–11 INT	05710	051144-05710-8	10	250



85411



100473

3M™ Hookit™ SBS Backup Pad

3M Hookit SBS backup pad provides a quick change advantage yet produces exceptional finishes on today's paints. You get easy attachment, quick removal and accurate centering with either the compounding or polishing pad with the 3M Hookit Attachment System.

Size	Part #	UPC	Max RPM	Qty/Inner	Qty/Case
7" x 3/4"	05717	051131-05717-3	3,000	1	1



100521



119634

Scotch-Brite™ Hand Pad Trial Pack No. 961S

A convenient pack of assorted hand pads helps you decide which product is right for you. Pack contains scrubbing sponge, extra duty pad, light duty pad, light duty cleansing pad, blending pad, general purpose pad, ultra fine pad and the 3M™ Twist-Lok™ Holder.

Part #	UPC	Qty/Inner	Qty/Case
961S	048011-17144-9	1	5



291769

3M™ NTN Maintenance and Repair Kit

Use on right angle grinders. Kit contains one each: 3M TN Disc Pad; Scotch-Brite™ TN RS Disc; Scotch-Brite TN Quick Change Clean & Strip XT Disc; 3M TN Fibre Disc 785C; 3M TN Flap Disc 747D.

Size	Part #	UPC	Qty/Case
4-1/2"	33013	048011-33013-6	5



213599

Scotch-Brite™ Coating Removal Disc Pack

Introductory pack containing one 4" disc constructed of heavy duty, semi-open web used to clean rust and paint and one 3M Disc Pad Holder 914.

Size	Part #	UPC	Max RPM	Qty/Case
4"	914CS	048011-18428-9	13,000	5



14374

Scotch-Brite™ Roloc™ Bristle Disc Intro Pack

Kit contains six Radial Bristle Discs: (2) grade 50; (2) grade 80 and (2) grade 120 as well as a 3M™ Roloc™ Disc Pad Holder, hard.

Size	Part #	UPC	Qty/Case
2"	982BS	048011-18696-2	5
3"	983BS	048011-18697-9	5



352099

3M™ Roloc™ Disc Intro Pack

Convenient introductory pack containing a variety of 3M Roloc Discs, Unitized Wheels and Bristle Discs. Includes 3M Disc Pad Holder.

Intro Pack Contents:

- 3M™ Roloc™ Disc 777F: 3 each in grades 60, 80 and 120
- Scotch-Brite™ Roloc™ Surface Conditioning Discs: 2 each in grades S SFN (Gray), A VFN (blue), A MED (Maroon) and A CRS (Brown)
- Scotch-Brite™ Roloc SE Surface Conditioning Discs: 2 each in grade A CRS (Brown)
- Scotch-Brite™ Roloc™ EXL Unitized Wheels: 1 each in grades 2S FIN, 6A MED, and 8A CRS
- Scotch-Brite™ Roloc™ Bristle Discs: 2 each in grades 50, 80 and 120

Size	Part #	UPC	Qty/Case
2"	982RS	048011-18694-8	5
3"	983RS	048011-18695-5	5

3M™ Roloc™ Disc Pack

Convenient introductory pack includes Scotch-Brite™ Roloc™ Surface Conditioning Discs, 3M™ Coated Abrasive Discs and 3M™ Roloc Disc Pad. An easy way to evaluate the right product, size and grade for your application.

Intro Pack Contents:

3M™ Roloc™ Disc 777F: 3 each in grades 60, 80 and 120
 Scotch-Brite™ Roloc™ Surface Conditioning Discs: 2 each in grades S SFN (Gray), A VFN (Blue), A MED (Maroon) and A CRS (Brown)

Size	Part #	UPC	Qty/Inner	Qty/Case
1-1/2"	9815S	051144-82901-9	1	5
2"	982S	051144-82899-9	1	5
3"	983S	051144-82900-2	1	5



Scotch-Brite™ Roloc™ Surface Conditioning Disc Pack

A convenient introductory pack containing 2" and 3" 3M Roloc Surface Conditioning Discs—2 in each grade: S SFN (Gray), A VFN (Blue), A MED (Maroon) and A CRS (Brown). Also contains 2" and 3" disc pads and 1/4" threaded shaft.

Size	Part #	UPC	Qty/Case
2" and 3"	985S	048011-18254-4	5



Scotch-Brite™ Unitized Wheel Intro Pack

Kit contains six wheels: 1 each of grades 2A MED, 2S FIN, 6A MED, 6S FIN, and 8A CRS as well as 1 3M Roloc+ Holder.

Size	Part #	UPC	Qty/Case
2"	987S	048011-17181-4	5
3"	988S	048011-17182-1	5

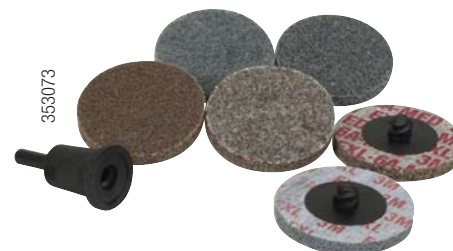

Scotch-Brite™ Star Intro Pack

Kit contains a variety of Scotch-Brite™ Stars: 2 each of grades A VFN and A CRS in 1-1/2", 2", 3" and 4" diameters. Also includes a 3M Mandrel 944.

Size	Part #	UPC	Qty/Case
Various	944S	048011-18255-1	5



Scotch-Brite™ Surface Conditioning Disc Intro Pack

Kit contains discs in grades S SFN (Gray), A VFN (Blue), A MED (Maroon) and A CRS (Brown). Also contains appropriate size 3M Disc Pad Holder, 5/8"—11 INT. (Kit 920S contains a 2" and 3" Disc Pad Holder, 1/4" shaft).

Size	Part #	UPC	Qty/Case
2" and 3"	920S	048011-18253-7	5
4-1/2"	9145S	048011-14105-3	5
4"	914S	048011-08707-8	5
5"	915S	048011-08713-9	5
7"	917S	048011-04270-1	5



Scotch-Brite™ Unitized Wheel Intro Pack

A convenient introductory pack containing several Scotch-Brite Unitized Wheels in a variety of densities and grades. Also includes 3M Mandrel No. 936 and 990.

Intro Pack Contents:

- 1" x 1" x 3/16": 1 each in grades 2S FIN, 2A MED, 6A MED, 8A CRS
- 3" x 1/4" x 3/8": 1 each in grades 2S FIN, 2A MED, 6A MED, 8A CRS



352098

Part #	UPC	Qty/Case
990S	048011-18245-2	5

Scotch-Brite™ EXL Unitized Wheel Intro Pack

Convenient introductory pack containing 26 Scotch-Brite EXL Unitized Wheels in a variety of sizes, densities, and grades. Also includes 3M Mandrel No. 992, 994, 996 and 998.

Intro Pack Contents:

- 1/2" x 1/8" x 1/8": 4 each 6A MED, 8A CRS
- 1" x 1/4" x 1/8": 2 each 2S FIN
- 1" x 1/8" x 1/8": 2 each 6A MED, 8A CRS, 2S FIN
- 1-1/2" x 1/4" x 3/16": 2 each 6A MED, 8A CRS, 2S FIN
- 2" x 1/4" x 3/16": 2 each 6A MED, 8A CRS



353076

Part #	UPC	Qty/Case
992S	048011-15509-8	5

Scotch-Brite™ EXL Deburring Wheel Pack

Pack containing one Scotch-Brite EXL Deburring Wheel 8A medium 6" x 1" x 1", one EXL Unitized Wheel 2A medium 6" x 1/2" x 1" and one each of the 1" x 1/2" x 1/2" and 1" x 1" x 1/2" 3M Flange Adaptor No. 5.



353077

Part #	UPC	Qty/Case
EXL	048011-16405-2	5

3M™ Finesse-it™ Polishes

Specially designed polishes for use on automotive OEM clearcoats to remove sand scratches or to remove swirl marks from previous steps. For industrial use only.

Cut and Finish comparison of various 3M™ Finesse-it™ Polishes.

UF = Ultra Fine
 EF = Extra Fine
 FF = Final Finish
 P = Purple
 FM = Finishing Material

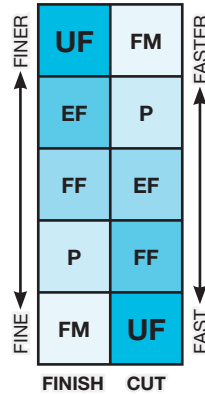

3M™ Finesse-it™ Finishing Material

Designed to buff out sanding scratches, eliminating or minimizing the defects in an automobile finish. “Easy Clean Up” means the product is specifically formulated to dry faster, making it easier to wipe off. In some cases, this buffing compound leaves an acceptable finish that may not require an additional step.

Size	Description	Part #	UPC	Qty/Case
Quart	Easy Clean Up (FM)	81235	051144-81235-6	12
Gallon	Easy Clean Up (FM)	13084	051144-13084-9	4
	Original Formula (FM)	81820	051144-81820-4	4



3M™ Finesse-it™ Final Finish

Used with a random orbital sander, Final Finish will refine the swirls left from the previous buffing process, giving you an excellent finish. “Easy Clean Up” means the product is specifically formulated to dry faster, making it easier to wipe off. Gray color.

Size	Description	Part #	UPC	Qty/Case
Quart	Easy Clean Up (FF)	82877	051144-82877-7	12
Gallon	Easy Clean Up (FF)	82878	051144-82878-4	4



3M™ Finesse-it™ Polishes

Specially designed polishes for use on automotive OEM clearcoats to remove sand scratches or to remove swirl marks from previous steps. For industrial use only. See Cut and Finish comparison diagram.

Size	Description	Part #	UPC	Qty/Case
Gallon	Purple (P)	51056	051111-51157-2	4
	Extra Fine (EF)	06002	051131-06002-9	4
	Ultra Fine (UF)	61084	051111-61084-8	4





86378

86489

3M™ Finesse-it™ Compounding Material

These products are ideal for reducing or eliminating standing scratches that are left over from top coat defect removal. Their precisely graded mineral provides an exceptionally fast cut while generating a uniform finish. They offer excellent results on catalyzed lacquer, nitrocellulose lacquer, varnish, polyester and polyurethane top coat finishes. The ivory version is recommended for light-colored finishes and ebony is ideal for darker finishes.

Size	Description	Part #	UPC	Qty/Case
Gallon	Ebony	77341	051144-77341-1	4
	Ivory	77340	051144-77340-4	4



86376

3M™ Finesse-it™ Finishing Material

This material is designed to follow the compounding operation and further refine top coat finishes. It improves clarity and gloss when needed. Use on darker finishes. In many cases this can be the last step in the woodworking finishing operation.

Size	Description	Part #	UPC	Qty/Case
Gallon	Ebony	76504	051144-76504-1	4



84831

3M™ Finesse-it™ Marine Paste Compound

Well suited for boat reconditioning of heavily oxidized surfaces/finishes, removing P800 sand scratches on production gelcoat and grade 100 or 1200 sand scratches on tooling gelcoat. White color reduces potential for staining of light-colored boats. Long working time requires less compound to be used per application.

Size	Description	Part #	UPC	Qty/Case
Gallon	White	06039	051131-06039-5	4

3M™ Glass Polishing Compound

This compound is comprised of cerium oxide mineral and water. Typically used for defect repair and scratch removal on assorted glass surfaces and parts.

Size	Part #	UPC	Qty/Case
Liter	6015	051111-61009-1	

Part #	UPC #	3M ID #	Page #	Part #	UPC #	3M ID #	Page #
01908	051111-55766-2	60-5100-2635-8	27	05530	051144-05530-2	60-9800-0893-6	26
01912	051135-92500-3	60-9800-3617-6	35	05538	051131-05538-4	60-9800-3286-0	5
01920	051111-60315-4	60-9801-0661-5	4	05539	051144-05539-5	60-9800-2896-7	5
01927	051111-51043-8	60-9800-3772-9	36	05540	051144-05540-1	60-9800-2897-5	5
01950	051111-56454-7	60-9801-0597-1	11	05541	051131-05541-4	60-9800-1804-2	5
01962	051135-92502-7	60-9800-3620-0	34	05545	051131-05545-2	60-9800-1196-3	9
01963	051111-60799-2	60-9801-0673-0	36	05546	051131-05546-9	60-9800-1197-1	9
02002	051111-56498-1	60-9801-0641-7	27	05555	051131-05555-1	60-9800-1143-5	9
02134	051111-60899-9	60-9801-0648-2	14	05555B	051111-51173-2	60-9800-3997-2	9
02140	051111-56573-5	60-9801-0501-3	2	05556	051131-05556-8	60-9800-1144-3	9
02154	051111-56509-4	60-9801-0652-4	15	05558	051131-05558-2	60-9800-0982-7	8
02155	051111-60525-7	60-9801-0657-3	6	05568	051131-05568-1	60-9800-1063-5	8
02223	051111-56456-1	60-9801-0599-7	9	05575	051144-05575-3	60-9800-0925-6	8
02250	051111-56508-7	60-9801-0651-6	15	05575B	051111-51170-1	60-9800-3994-9	8
02286	051111-56479-0	60-9801-0622-7	6	05576	051144-05576-0	60-9800-0926-4	8
02322	051131-02322-2	60-9800-4335-4	16	05576B	051111-51172-5	60-9800-3996-4	8
02325	051111-55828-7	60-9801-0545-0	14	05577	051144-05577-7	60-9800-0638-5	8
02327	051111-51074-2	60-9800-3669-7	16	05578	051144-05578-4	60-9800-0639-3	8
02328	051111-51070-4	60-9800-3665-5	16	05579	051144-05579-1	60-9800-0641-9	8
02329	051111-51073-5	60-9800-3668-9	16	05581	051131-05581-0	60-9800-0911-6	8
02331	051111-51072-8	60-9800-3667-1	16	05582	051131-05582-7	60-9800-0964-5	8
02333	051111-51071-1	60-9800-3666-3	16	05585	051144-05585-2	60-9800-0620-3	26
02345	051111-50198-6	60-9800-3646-5	34	05586	051144-05586-9	60-9800-0621-1	26
02362	051111-51076-6	60-9801-0727-4	35	05589	051131-05589-6	60-9800-1407-4	26
02362B	051111-60528-8	60-9801-0806-6	35	05591	051131-05591-9	60-9800-1535-2	26
02507	051111-55830-0	60-9801-0547-6	14	05620	051144-05620-0	60-9801-0841-3	2
02511	051111-51150-3	60-9800-3980-8	34	05621	051144-05621-7	60-9801-0840-5	2
02599	051111-55792-1	60-9800-4518-5	11	05622	051144-05622-4	60-9801-0839-7	2
02618	051111-51047-6	60-9800-3818-0	2	05637	051131-05637-4	60-9800-3475-9	2
02637	051111-51158-9	60-9801-0726-6	35	05645	051131-05645-9	60-9800-1198-9	10
02648	051111-51151-0	60-9801-0725-8	35	05646	051131-05646-6	60-9800-1199-7	10
02648B	051111-60527-1	60-9801-0805-8	35	05655	051131-05655-8	60-9800-1033-8	10
02700	051111-55764-8	60-9800-4517-7	11	05655B	051111-51166-4	60-9800-3991-5	10
02712	051111-55845-4	60-9801-0567-4	26	05656	051131-05656-5	60-9800-1034-6	10
02713	051111-55846-1	60-9801-0568-2	26	05700	051144-05700-9	60-9800-2888-4	37
02727	051111-55833-1	60-9801-0550-0	34	05701	051144-05701-6	60-9800-2889-2	37
02764	051111-55831-7	60-9801-0548-4	15	05705	051144-05705-4	60-9800-2336-4	37
02787	051111-60900-2	60-9801-0653-2	7	05710	051144-05710-8	60-9800-0729-2	37
02795	051111-56459-2	60-9801-0602-9	9	05717	051131-05717-3	60-9800-0996-7	13, 37
02814	051111-55793-8	60-9800-4519-3	11	05720	051144-05720-7	70-0709-3344-8	37
05240	051131-05240-6	60-9800-2875-1	29	05723	051131-05723-4	60-9800-1765-5	36
05241	051131-05241-3	60-9800-2876-9	29	05725	051131-05725-8	60-9800-1389-4	36
05242	051131-05242-0	60-9800-2877-7	29	05726	051131-05726-5	60-9800-1758-0	36
05244	051131-05244-4	60-9800-2789-4	29	05727	051131-05727-2	60-9800-1759-8	36
05245	051131-05245-1	60-9800-2899-1	15	05740	051131-05740-1	60-9800-3278-7	28
05248	051131-05248-2	60-9800-2791-0	32	05741	051131-05741-8	60-9800-3280-3	28
05251	051131-05251-2	60-9800-3507-9	14	05742	051131-05742-5	60-9800-2655-7	29
05255	051131-05255-0	60-9800-2900-7	15	05744	051131-05744-9	60-9800-3282-9	29
05269	051131-05269-7	60-9801-0585-6	14	05755	051131-05755-5	60-9800-1492-6	12
05270	051131-05270-3	60-9801-0700-1	14	05756	051131-05756-2	60-9800-1493-4	12
05271	051131-05271-0	60-9801-0889-2	16	05768	051131-05768-5	60-9800-1594-9	11
05273	051131-05273-4	60-9800-2793-6	16	05769	051131-05769-2	60-9800-2688-8	11
05274	051131-05274-1	60-9800-2794-4	16	05771	051131-05771-5	60-9800-2454-5	13
05275	051131-05275-8	60-9800-2784-5	14	05773	051131-05773-9	60-9800-1961-0	13
05276	051131-05276-5	60-9800-2785-2	14	05774	051131-05774-6	60-9800-1943-8	13
05279	051131-05279-6	60-9800-2786-0	14	05775	051131-05775-3	60-9800-1891-9	11
05281	051131-05281-9	60-9800-2803-3	14	05776	051131-05776-0	60-9800-1392-8	11
05286	051131-05286-4	60-9800-3631-7	14	05779	051131-05779-1	60-9800-1393-6	11
05291	051131-05291-8	60-9800-2787-8	27	05781	051131-05781-4	60-9800-1394-4	11
05292	051131-05292-5	60-9800-2788-6	27	05782	051131-05782-1	60-9800-1484-3	11
05345	051131-05345-8	60-9800-3298-5	16	05791	051131-05791-3	60-9800-2670-6	27
05351	051131-05351-9	60-9800-3542-6	15	05792	051131-05792-0	60-9800-2671-4	27
05355	051131-05355-7	60-9800-2796-9	16	05855	051131-05855-2	60-9800-1960-2	13
05356	051131-05356-4	60-9800-2797-7	16	05856	051131-05856-9	60-9800-1560-0	13
05375	051131-05375-5	60-9800-3299-3	15	05876	051131-05876-7	60-9800-1615-2	12
05440	051144-05440-4	60-9801-0775-3	28	05925	051131-05925-2	60-9800-1005-6	35
05441	051144-05441-1	60-9801-0776-1	28	05975	051131-05975-7	60-9800-1030-4	32
05442	051144-05442-8	60-9800-0874-6	28	06002	051131-06002-9	60-9801-0518-7	41
05444	051144-05444-2	60-9801-0774-6	28	06039	051131-06039-5	60-9800-1200-3	42
05448	051144-05448-0	60-9801-0773-8	32	06541	051111-56599-5	60-9801-0664-9	25
05450	051144-05450-3	60-9801-0450-3	30	06612	051111-56460-8	60-9801-0603-7	8
05452	051144-05452-7	60-9800-0854-8	30	06613	051111-55834-8	60-9801-0551-8	34
05510	051144-05510-4	60-9800-0695-5	3	06624	051111-56462-2	60-9801-0605-2	26
05517	051144-05517-3	60-9800-0685-6	32	06661	051111-60317-8	60-9801-0674-8	11
05518	051144-05518-0	60-9800-0686-4	32	07390	051131-07390-6	60-9800-1614-5	12
05519	051144-05519-7	60-9800-2014-7	26	07394	051131-07394-4	60-9800-2775-3	11
05520	051131-05520-9	60-9800-1745-7	26	08051	051135-08051-1	60-9800-2705-0	8
05526	051131-05526-1	60-9800-1193-0	28	09347	051131-09347-8	60-9800-3487-4	14

INDEX

Part #	UPC #	3M ID #	Page #	Part #	UPC #	3M ID #	Page #
09352	051131-09352-2	60-9800-3578-0	15	29535	051135-92689-5	60-0001-0234-7	22
09357	134375-38287-8	XS-0034-9019-9	35	29536	051135-92689-5	60-0001-0234-7	22
09358	134375-38286-1	XS-0034-9020-7	35	29537	051135-92689-5	60-0001-0234-7	23
1	048011-13900-5	61-5000-5954-0	33	29538	051135-92689-5	60-0001-0234-7	23
1	048011-15408-4	61-5000-7816-9	6	29539	051135-92689-5	60-0001-0234-7	23
1&7	048011-14915-8	61-5000-7234-5	19	29540	051135-92689-5	60-0001-0234-7	23
11063	051144-11063-6	60-9800-2459-4	26	29541	051135-92689-5	60-0001-0234-7	23
11823	051144-11823-6	60-9800-1119-5	2	29542	051135-92689-5	60-0001-0234-7	23
11824	051144-11824-3	60-9800-1117-9	2	29543	051135-92689-5	60-0001-0234-7	23
13070	051144-13070-2	60-9800-1479-3	33	29544	051135-92689-5	60-0001-0234-7	23
13071	051144-13071-9	60-9800-1478-5	33	29545	051135-92689-5	60-0001-0234-7	23
13084	051144-13084-9	60-9800-1329-0	41	29546	051135-92689-5	60-0001-0234-7	23
13325	051144-13325-3	60-9801-0820-7	1	29547	051135-92689-5	60-0001-0234-7	23
13441	051144-13441-0	60-9801-0842-1	34	29548	051135-92689-5	60-0001-0234-7	23
13442	051144-13442-7	60-9800-0967-8	34	29549	051135-92689-5	60-0001-0234-7	23
13446	051144-13446-5	60-9800-1066-8	35	29550	051135-92689-5	60-0001-0234-7	23
13625	051144-13625-4	60-9800-2656-5	11	29551	051135-92689-5	60-0001-0234-7	23
14197	051144-14197-5	60-9800-2871-0	5	29552	051135-92689-5	60-0001-0234-7	23
14198	051144-14198-2	60-9800-2872-8	5	29553	051135-92689-5	60-0001-0234-7	23
14201	051144-14201-9	60-9800-2874-4	5	29554	051135-92689-5	60-0001-0234-7	23
14202	051144-14202-6	60-9800-2873-6	5	29555	051135-92689-5	60-0001-0234-7	23
14211	051144-14211-8	60-9800-2868-6	5	29556	051135-92689-5	60-0001-0234-7	23
14212	051144-14212-5	60-9800-2867-8	5	29557	051135-92689-5	60-0001-0234-7	23
14215	051144-14215-6	60-9800-2870-2	5	29558	051135-92689-5	60-0001-0234-7	23
14216	051144-14216-3	60-9800-2869-4	5	29559	051135-92689-5	60-0001-0234-7	23
14270	051144-14270-5	60-9801-0824-9	1	29560	051135-92689-5	60-0001-0234-7	23
14307	051144-14307-8	60-9800-1072-6	31	29700	051135-92688-8	60-0001-0155-4	24
14308	051144-14308-5	60-9800-1073-4	31	29701	051135-92688-8	60-0001-0155-4	24
14736	051144-14736-6	60-9800-1107-0	34	29702	051135-92688-8	60-0001-0155-4	24
14736V	051111-51168-8	60-9800-3983-2	34	29703	051135-92688-8	60-0001-0155-4	24
14738	051144-14738-0	60-9800-2658-1	37	29704	051135-92688-8	60-0001-0155-4	24
14739	051144-14739-7	60-9800-1122-9	34	29705	051135-92688-8	60-0001-0155-4	24
18368	048011-18368-8	61-5001-1952-6	33	29706	051135-92688-8	60-0001-0155-4	24
18444	048011-18444-9	61-5001-2041-7	11	29707	051135-92688-8	60-0001-0155-4	24
2	048011-13901-2	61-5000-5955-7	33	29708	051135-92688-8	60-0001-0155-4	24
250	048011-12929-7	61-5000-4913-7	30	29710	051135-92688-8	60-0001-0155-4	24
250HD	048011-33608-4	61-5001-9173-1	30	29711	051135-92688-8	60-0001-0155-4	24
261	048011-05717-0	61-5000-3235-6	30	29712	051135-92688-8	60-0001-0155-4	25
27628	048011-27628-1	61-5001-5173-5	18	29713	051135-92688-8	60-0001-0155-4	25
27680	048011-27680-9	61-5001-5226-1	18	29714	051135-92688-8	60-0001-0155-4	24
27681	048011-27681-6	61-5001-5227-9	18	29715	051135-92688-8	60-0001-0155-4	24
27682	048011-27682-3	61-5001-5228-7	18	29716	051135-92688-8	60-0001-0155-4	25
27683	048011-27683-0	61-5001-5229-5	18	29717	051135-92688-8	60-0001-0155-4	25
27684	048011-27684-7	61-5001-5230-3	18	29718	051135-92688-8	60-0001-0155-4	24
29501	051135-92689-5	60-0001-0234-7	22	29719	051135-92688-8	60-0001-0155-4	24
29502	051135-92689-5	60-0001-0234-7	22	29720	051135-92688-8	60-0001-0155-4	25
29503	051135-92689-5	60-0001-0234-7	22	29721	051135-92688-8	60-0001-0155-4	25
29504	051135-92689-5	60-0001-0234-7	22	29722	051135-92688-8	60-0001-0155-4	24
29505	051135-92689-5	60-0001-0234-7	22	29723	051135-92688-8	60-0001-0155-4	24
29506	051135-92689-5	60-0001-0234-7	22	29724	051135-92688-8	60-0001-0155-4	25
29507	051135-92689-5	60-0001-0234-7	22	29725	051135-92688-8	60-0001-0155-4	25
29508	051135-92689-5	60-0001-0234-7	22	29726	051135-92688-8	60-0001-0155-4	24
29509	051135-92689-5	60-0001-0234-7	22	29727	051135-92688-8	60-0001-0155-4	24
29510	051135-92689-5	60-0001-0234-7	22	29728	051135-92688-8	60-0001-0155-4	25
29511	051135-92689-5	60-0001-0234-7	22	29729	051135-92688-8	60-0001-0155-4	25
29512	051135-92689-5	60-0001-0234-7	22	29730	051135-92688-8	60-0001-0155-4	24
29513	051135-92689-5	60-0001-0234-7	22	29731	051135-92688-8	60-0001-0155-4	24
29514	051135-92689-5	60-0001-0234-7	22	29732	051135-92688-8	60-0001-0155-4	25
29515	051135-92689-5	60-0001-0234-7	22	29733	051135-92688-8	60-0001-0155-4	25
29516	051135-92689-5	60-0001-0234-7	22	29734	051135-92688-8	60-0001-0155-4	24
29517	051135-92689-5	60-0001-0234-7	22	29735	051135-92688-8	60-0001-0155-4	24
29518	051135-92689-5	60-0001-0234-7	22	29736	051135-92688-8	60-0001-0155-4	25
29519	051135-92689-5	60-0001-0234-7	22	29737	051135-92688-8	60-0001-0155-4	25
29520	051135-92689-5	60-0001-0234-7	22	29738	051135-92688-8	60-0001-0155-4	24
29521	051135-92689-5	60-0001-0234-7	22	29739	051135-92688-8	60-0001-0155-4	24
29522	051135-92689-5	60-0001-0234-7	22	29740	051135-92688-8	60-0001-0155-4	25
29523	051135-92689-5	60-0001-0234-7	22	29741	051135-92688-8	60-0001-0155-4	25
29524	051135-92689-5	60-0001-0234-7	22	29742	051135-92688-8	60-0001-0155-4	24
29525	051135-92689-5	60-0001-0234-7	22	29743	051135-92688-8	60-0001-0155-4	24
29526	051135-92689-5	60-0001-0234-7	22	29744	051135-92688-8	60-0001-0155-4	25
29527	051135-92689-5	60-0001-0234-7	22	29745	051135-92688-8	60-0001-0155-4	25
29528	051135-92689-5	60-0001-0234-7	22	29746	051135-92688-8	60-0001-0155-4	24
29529	051135-92689-5	60-0001-0234-7	22	29747	051135-92688-8	60-0001-0155-4	24
29530	051135-92689-5	60-0001-0234-7	22	29748	051135-92688-8	60-0001-0155-4	25
29531	051135-92689-5	60-0001-0234-7	22	29750	051135-92688-8	60-0001-0155-4	24
29532	051135-92689-5	60-0001-0234-7	22	29751	051135-92688-8	60-0001-0155-4	24
29533	051135-92689-5	60-0001-0234-7	22	29752	051135-92688-8	60-0001-0155-4	25
29534	051135-92689-5	60-0001-0234-7	22	29754	051135-92688-8	60-0001-0155-4	24

Part #	UPC #	3M ID #	Page #	Part #	UPC #	3M ID #	Page #
29755	051135-92688-8	60-0001-0155-4	24	45216	051144-45216-3	60-9800-0872-0	8
300	048011-04019-6	61-9888-3000-8	20	45217	051144-45217-0	60-9800-0896-9	10
30133	048011-30133-4	61-5001-7614-6	18	45218	051144-45218-7	60-9800-0897-7	10
33013	048011-33013-6	61-5001-8797-8	38	45220	051144-45220-0	60-9800-0908-2	27
33079	048011-33079-2	61-5001-8942-0	18	5	048011-33248-2	61-5001-9093-1	20
33092	048011-33092-1	61-5001-8983-4	18	5	048011-16860-9	61-5000-9448-9	20
33093	048011-33093-8	61-5001-8984-2	18	5	048011-16859-3	61-5000-9447-1	20
356	048011-03913-8	61-5000-0175-7	20	5	048011-30000-9	61-5001-5335-0	20
40	048011-08909-6	61-5000-3934-4	22	50199	051111-50199-3	60-9800-3649-9	34
400U	048011-91139-7	61-0000-1443-3	20	50200	051111-50200-6	60-9800-3650-7	15
400V	048011-91140-3	61-0000-1444-1	20	50201	051111-50201-3	60-9800-3651-5	15
45032	051144-45032-9	60-9887-0943-6	19	50202	051111-50202-0	60-9800-3652-3	15
45033	051144-45033-6	60-9887-0941-0	19	50203	051111-50203-7	60-9800-3653-1	12
45034	051144-45034-3	60-9887-0939-4	19	50204	051111-50204-4	60-9800-3654-9	12
45035	051144-45035-0	60-9887-0937-8	19	50205	051111-50205-1	60-9800-3655-6	12
45038	051144-45038-1	60-9887-0909-7	19	50206	051111-50206-8	60-9800-3656-4	10
45040	051144-45040-4	60-9887-0902-2	19	50207	051111-50207-5	60-9800-3657-2	10
45068	051144-45068-8	60-9865-0677-6	3	50208	051111-50208-2	60-9800-3658-0	10
45069	051144-45069-5	60-9865-0625-5	3	51045	051111-51045-2	60-9800-3795-0	3
45070	051144-45070-1	60-9865-0623-0	3	51046	051111-51046-9	60-9800-3796-8	3
45071	051144-45071-8	60-9865-0622-2	3	51056	051111-51157-2	60-9800-3981-6	41
45072	051144-45072-5	60-9865-0621-4	3	54318	051111-56466-0	60-9801-0609-4	8
45073	051144-45073-2	60-9865-0620-6	3	6	048011-15059-8	61-5000-7411-9	19
45081	051144-45081-7	60-9800-0853-0	19	6015	051111-61009-1	60-0900-0596-2	42
45090	051144-45090-9	60-9800-1852-1	4	60529	051111-60529-5	60-9800-0851-2	16
45091	051144-45091-6	60-9800-2695-3	4	61084	051111-61084-8	60-5100-2790-1	41
45092	051144-45092-3	60-9800-2678-9	4	67356	051111-56492-9	60-9801-0634-2	13
45093	051144-45093-0	60-9800-1849-7	4	67415	051111-60311-6	60-9801-0672-2	7
45094	051144-45094-7	60-9800-1848-9	4	7	048011-15060-4	61-5000-7412-7	19
45095	051144-45095-4	60-9800-2676-3	4	70147	051111-56445-5	60-9801-0586-4	27
45096	051144-45096-1	60-9800-2696-1	4	70166	051111-56491-2	60-9801-0633-4	13
45097	051144-45097-8	60-9800-1845-5	4	70167	051111-55812-6	60-9801-0522-9	11
45098	051144-45098-5	60-9800-1844-8	4	70234	051111-55813-3	60-9801-0525-2	8
45099	051144-45099-2	60-9800-1843-0	4	70384	051111-56496-7	60-9801-0639-1	27
45100	051144-45100-5	60-9800-1842-2	4	70393	051111-55811-9	60-9801-0521-1	35
45101	051144-45101-2	60-9800-3794-3	4	70437	051135-92499-0	60-9800-3616-8	34
45102	051144-45102-9	60-9801-0811-6	6	70446	051111-60312-3	60-9801-0658-1	5
45116	051144-45116-6	60-9801-0816-5	31	70448	051111-60313-0	60-9801-0659-9	5
45117	051144-45117-3	60-9801-0814-0	31	70449	051111-56472-1	60-9801-0615-1	34
45118	051144-45118-0	60-9801-0815-7	31	7210	048011-03768-4	61-9865-1033-9	33
45119	051144-45119-7	60-9801-0812-4	31	7211	048011-03767-7	61-9865-1034-7	33
45120	051144-45120-3	60-9801-0813-2	31	7212	048011-05969-3	61-5000-3609-2	33
45121	051144-45121-0	60-9824-9151-0	31	76504	051144-76504-1	60-9800-1134-4	42
45123	051144-45123-4	60-9890-9057-0	25	76848	051144-76848-6	60-9800-1140-1	36
45124	051144-45124-1	60-9890-9053-9	25	77340	051144-77340-4	60-9800-1151-8	42
45127	051144-45127-2	60-9890-9045-5	24	77341	051144-77341-1	60-9800-1150-0	42
45129	051144-45129-6	60-9890-9043-0	24	77717	051144-77717-4	60-9800-1161-7	25
45130	051144-45130-2	60-9890-9040-6	24	77718	051144-77718-1	60-9800-1162-5	25
45131	051144-45131-9	60-9890-9039-8	24	77720	051144-77720-4	60-9800-1164-1	25
45132	051144-45132-6	60-9890-9038-0	24	77721	051144-77721-1	60-9800-1165-8	25
45137	051144-45137-1	60-9890-9031-5	24	77722	051144-77722-8	60-9800-1166-6	25
45138	051144-45138-8	60-9890-9030-7	24	77723	051144-77723-5	60-9800-1866-1	5
45139	051144-45139-5	60-9890-9029-9	24	77724	051144-77724-2	60-9800-1854-7	5
45144	051144-45144-9	60-9890-9021-6	24	77726	051144-77726-6	60-9800-1868-7	5
45145	051144-45145-6	60-9890-9020-8	24	77728	051144-77728-0	60-9800-1855-4	5
45146	051144-45146-3	60-9890-9019-0	24	77729	051144-77729-7	60-9800-1856-2	5
45147	051135-92688-8	60-0001-0155-4	24	77740	051144-77740-2	60-9800-1865-3	5
45148	051144-45148-7	60-9890-9018-2	24	77749	051144-77749-5	60-9800-1186-4	27
45152	051144-45152-4	60-9890-9011-7	24	77750	051144-77750-1	60-9800-2369-5	27
45153	051144-45153-1	60-9890-9010-9	24	77751	051144-77751-8	60-9800-2672-2	11
45156	051144-45156-2	60-9890-9008-3	24	77752	051144-77752-5	60-9801-0818-1	27
45159	051144-45159-3	60-9890-9000-0	24	77855	051144-77855-3	60-9800-2659-9	12
45179	051144-45179-1	60-9800-1853-9	4	77856	051144-77856-0	60-9800-2660-7	13
45188	051144-45188-3	60-9801-0819-9	26	80	048011-30201-0	61-5001-7696-3	21
45189	051144-45189-0	60-9801-0817-3	26	80514	051144-80514-3	60-9801-0822-3	1
45190	051144-45190-6	60-9800-0651-8	2	80515	051144-80515-0	60-9801-0821-5	1
45192	051144-45192-0	60-9801-0829-8	1	80516	051144-80516-7	60-9801-0823-1	1
45193	051144-45193-7	60-9801-0828-0	1	80517	051144-80517-4	60-9801-0831-4	1
45194	051144-45194-4	60-9801-0834-8	1	81108	051144-81108-3	60-9800-1410-8	29
45195	051144-45195-1	60-9801-0835-5	1	81235	051144-81235-6	60-9800-1411-6	41
45198	051144-45198-2	60-9800-1488-4	26	81322	051144-81322-3	60-9800-1490-0	29
45203	051144-45203-3	60-9800-0763-1	28	81349	051144-81349-0	60-9800-1506-3	14
45204	051144-45204-0	60-9800-0764-9	28	81350	051144-81350-6	60-9800-1507-1	14
45205	051144-45205-7	60-9800-0808-4	2	81351	051144-81351-3	60-9800-1480-1	14
45206	051144-45206-4	60-9801-0832-2	1	81352	051144-81352-0	60-9800-1508-9	14
45207	051144-45207-1	60-9801-0830-6	1	81353	051144-81353-7	60-9800-1509-7	14
45208	051144-45208-8	60-9801-0833-0	1	81732	05144-81732-0	60-9801-0826-4	1
45215	051144-45215-6	60-9800-0871-2	8	81470	051144-81470-1	60-9800-1429-8	35

INDEX

Part #	UPC #	3M ID #	Page #	Part #	UPC #	3M ID #	Page #
81471	051144-81471-8	60-9800-1430-6	35	88743	051144-88743-9	60-9800-3156-5	2
81672	051144-81672-9	60-9800-1491-8	8	88746	051111-51155-8	60-9800-3977-4	4
81728	051144-81728-3	60-9801-0837-1	1	88748	051144-88748-4	60-9800-3161-5	4
81729	051144-81729-0	60-9801-0838-9	1	88765	051144-88765-1	60-9800-3481-7	3
81733	051144-81733-7	60-9801-0827-2	1	88769	051144-88769-9	60-9800-3506-1	3
81734	051144-81734-4	60-9801-0825-6	1		9	048011-22970-6	2
81735	051144-81735-1	60-9801-0836-3	1		9	048011-22971-3	2
81820	051144-81820-4	60-9800-0952-0	41		9	048011-22972-0	2
81821	051144-81821-1	60-9800-1510-5	8	9041	048011-17157-9	61-5000-9863-9	32
81915	051144-81915-7	60-9800-1657-4	28	905	048011-09448-9	61-5001-2391-6	17
81933	051144-81933-1	60-9800-1734-1	14	905FD	048011-24282-8	61-5001-3942-5	17
82178	051144-82178-5	60-9800-1563-4	8	906	048011-09449-6	61-5001-2392-4	17
82182	051144-82182-2	60-9800-1567-5	35	91136	048011-91136-6	61-0000-0107-5	33
82189	051144-82189-1	60-9800-1574-1	8		914	048011-05673-9	17
82191	051144-82191-4	60-9800-1576-6	27		914	048011-05674-6	17
82271	051144-82271-3	60-9800-1602-0	34		914	048011-05677-7	17
82274	051144-82274-4	60-9800-1604-6	10	9145	048011-14111-4	61-5001-2385-8	17
82455	051144-82455-7	60-9800-1635-0	6	9145	048011-14110-7	61-5001-3846-8	17
82456	051144-82456-4	60-9800-2661-5	27	9145	048011-14114-5	61-5001-3847-6	17
82457	051144-82457-1	60-9800-2662-3	27	9145FD	048011-32994-9	61-5001-7620-3	17
82531	051144-82531-8	60-9800-1658-2	35	9145S	048011-14105-3	61-5001-1758-7	39
82563	051144-82563-9	60-9800-1798-6	14	914CS	048011-18428-9	61-5001-2012-8	38
82564	051144-82564-6	60-9800-1799-4	7	914FD	048011-32996-3	61-5001-7618-7	17
82565	051144-82565-3	60-9800-1800-0	7	914S	048011-08707-8	61-5001-1757-9	39
82566	051144-82566-0	60-9800-1801-8	7	915	048011-05680-7	61-5001-2386-6	17
82567	051144-82567-7	60-9800-1802-6	7	915	048011-05679-1	61-5001-3848-4	17
82658	051144-82658-2	60-9800-1670-7	8	915	048011-05681-4	61-5001-3849-2	17
82659	051144-82659-9	60-9800-2663-1	12	915FD	048011-32991-8	61-5001-7623-7	17
82705	051144-82705-3	60-9800-1676-4	27	915FD	048011-32990-1	61-5001-7624-5	17
82790	051144-82790-9	60-9800-1709-3	8	915S	048011-08713-9	61-5001-1759-5	39
82793	051144-82793-0	60-9800-1712-7	26	916	048011-05682-1	61-5001-2387-4	17
82877	051144-82877-7	60-9800-1751-5	41	917	048011-09450-2	61-5001-2393-2	17
82878	051144-82878-4	60-9800-1752-3	41	917FD	048011-32988-8	61-5001-7626-0	17
82879	051111-55765-5	60-9800-4492-3	4	917S	048011-04270-1	61-5001-1760-3	39
82880	051144-82880-7	60-9800-2664-9	11	918	048011-09451-9	61-5001-2394-0	17
82975	051144-82975-0	60-9800-1826-5	6	918V	048011-24229-3	61-5001-3889-8	17
83242	051144-83242-2	60-9800-2063-4	4	920S	048011-18253-7	61-5001-1761-1	39
83489	051144-83489-1	60-9800-2064-2	4	9215	048011-04130-8	61-5000-1315-8	17
83980	051144-83980-3	60-9800-2113-7	4	922	048011-07494-8	61-5000-1316-6	17
84226	051111-51042-1	60-9800-3700-0	13	922	048011-18607-8	61-5001-2886-5	17
84229	051144-84229-2	60-9800-2306-7	26	922FV	048011-24230-9	61-5001-3890-6	17
84231	051144-84231-5	60-9800-2341-4	8	923	048011-04132-2	61-5000-1317-4	17
84993	051144-84993-2	60-9800-2506-2	4	924	048011-07492-4	61-5001-1318-2	17
84994	051144-84994-9	60-9800-2507-0	4	931	048011-13966-1	61-5000-6094-4	21
84997	051144-84997-0	60-9800-2526-0	4	932	048011-13967-8	61-5000-6095-1	21
84998	051144-84998-7	60-9800-2527-8	4	933	048011-13968-5	61-5000-6096-9	21
84999	051144-84999-4	60-9800-2528-6	4	934	048011-04021-9	61-9888-0934-1	21
85000	051144-85000-6	60-9800-2529-4	4	935	048011-04020-2	61-9888-0935-8	31
85001	051144-85001-3	60-9800-2530-2	4	936	048011-04018-9	61-9865-0825-9	21
85078	051144-85078-5	60-9800-2648-2	35	944	048011-13928-9	61-5000-5994-6	31
85079	051144-85079-2	60-9800-2649-0	35	944S	048011-18255-1	61-5001-1763-7	39
85083	051144-85083-9	60-9800-2770-4	36	947	051144-13627-8	60-9800-0980-1	11
85084	051144-85084-6	60-9800-2771-2	36	952	048011-04013-4	61-5000-1865-2	30
85087	051144-85087-7	60-9800-2901-5	27	961	048011-09493-4	61-5000-4615-8	30
85088	051144-85088-4	60-9800-2902-3	27	961S	048011-17144-9	61-5000-9698-9	38
85089	051144-85089-1	60-9800-2903-1	27	9815S	051144-82901-9	60-9800-1883-6	39
85095	051144-85095-2	60-9800-3134-2	27	982BS	048011-18696-2	61-5001-2981-4	38
85096	051144-85096-9	60-9800-3135-9	11	982RS	048011-18694-8	61-5001-2979-8	38
85097	051144-85097-6	60-9800-3136-7	6	982S	051144-82899-9	60-9800-1881-0	39
85099	051144-85099-0	60-9800-3138-3	36	983BS	048011-18697-9	61-5001-2982-2	38
85100	051144-85100-3	60-9800-3139-1	35	983RS	048011-18695-5	61-5001-2980-6	38
85101	051144-85101-0	60-9800-3140-9	35	983S	051144-82900-2	60-9800-1882-8	39
85103	051144-85103-4	60-9800-3142-5	35	985S	048011-18254-4	61-5001-1762-9	39
85104	051144-85104-1	60-9800-3143-3	8	987S	048011-17181-4	61-5001-1884-1	39
85105	051144-85105-8	60-9800-3144-1	11	988S	048011-17182-1	61-5001-1885-8	39
85286	051144-85286-4	60-9800-2153-3	6	990	048011-15012-3	61-5000-7334-3	21
85287	051144-85287-1	60-9800-2414-9	6	990S	048011-18245-2	61-5001-1558-1	40
85299	051144-85299-4	60-9800-2152-5	6	992S	048011-15509-8	61-5001-1764-5	40
86100	051111-60306-2	60-9801-0668-0	2	99736	051111-60788-6	60-9801-0666-4	26
88044	051111-50197-9	60-9800-3583-0	29	ALMEN	048011-03764-6	61-9865-1037-0	33
88132	051111-56493-6	60-9801-0635-9	27	EXL	048011-16405-2	61-5000-8933-1	40
88736	051144-88736-1	60-9800-3149-0	8	SJ3443	051144-94388-3	60-0000-5225-2	32
88737	051144-88737-8	60-9800-3150-8	36	SJ3551	051144-13662-9	60-9800-0983-5	32
88739	051144-88739-2	60-9800-3152-4	11	SJ3551	051144-76135-7	60-0000-5235-1	32
88741	051144-88741-5	60-9800-3154-0	27	WBWD	048011-04031-8	60-1529-8202-5	21
88742	051144-88742-2	60-9800-3155-7	26				

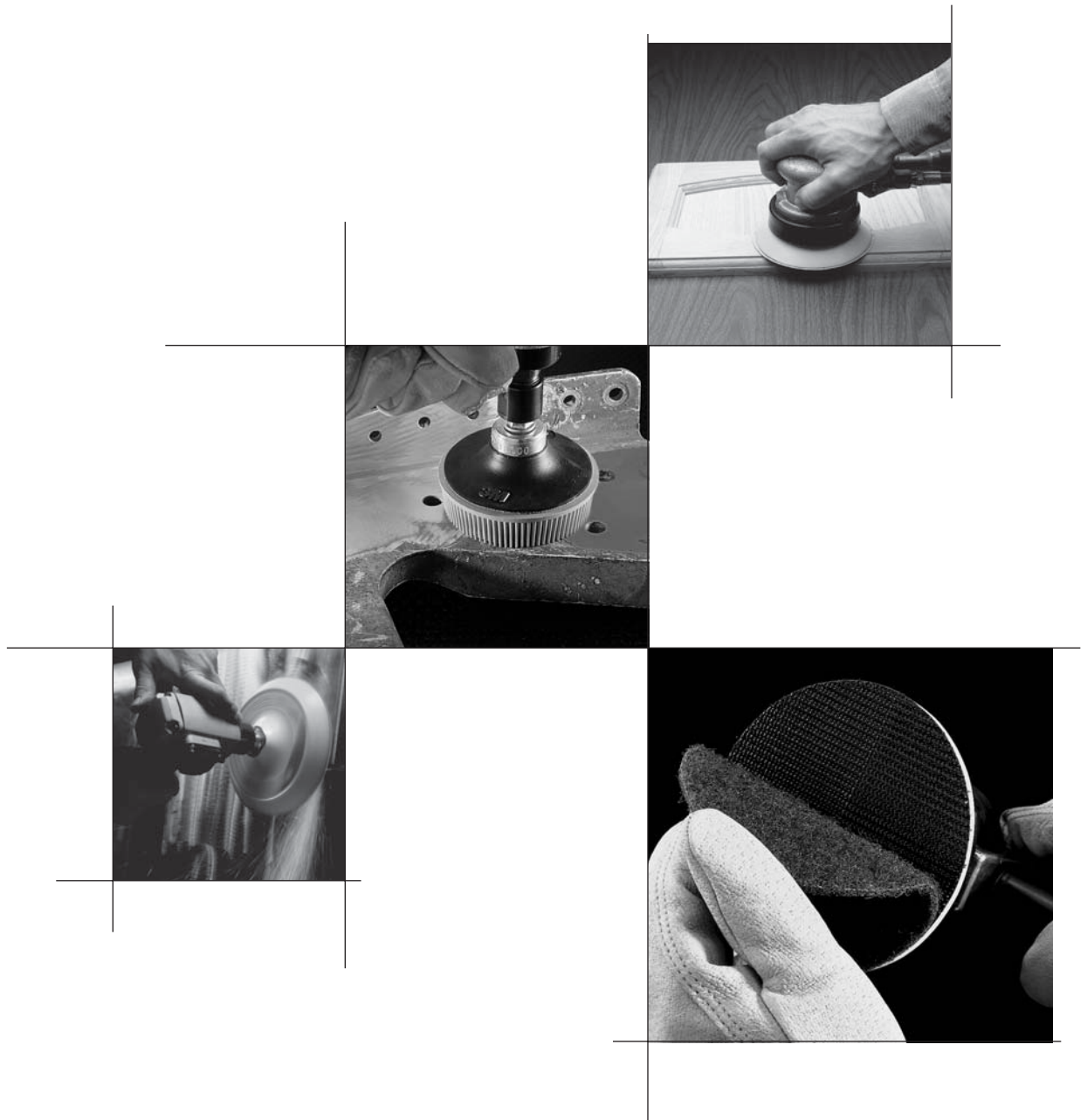

Additional accessories are available and may be purchased directly through Contract Production Services/CPS. Please contact Contract Production Services/CPS directly to check availability and other specific information. Use the part number to identify any specific item.

Contract Production Services/CPS
1936 Lyndale Avenue South
Minneapolis, MN 55403

Office Hours
Monday – Friday from 7:00am – 3:00pm (Central Time)
1-800-843-0619
612-871-2222
fax: 612-872-0189
www.VLRW.com

Important Notice to Purchaser

Product Use: All statements, technical information and recommendations contained in this document are based upon tests or experience that 3M believes are reliable. However, many factors beyond 3M's control can affect the use and performance of a 3M product in a particular application, including the conditions under which the product is used and the time and environmental conditions in which the product is expected to perform. Since these factors are uniquely within the user's knowledge and control, it is essential that the user evaluate the 3M product to determine whether it is fit for a particular purpose and suitable for the user's method of application.

Warranty and Limited Remedy: Unless stated otherwise in 3M's product literature, packaging inserts or product packaging for individual products, 3M warrants that each 3M product meets the applicable specifications at the time 3M ships the product. Individual products may have additional or different warranties as stated on product literature, package inserts or product packages. **3M MAKES NO OTHER WARRANTIES, EXPRESS OR IMPLIED, INCLUDING, BUT NOT LIMITED TO, ANY IMPLIED WARRANTY OF MERCHANTABILITY OR FITNESS FOR A PARTICULAR PURPOSE OR ANY IMPLIED WARRANTY ARISING OUT OF A COURSE OF DEALING, CUSTOM OR USAGE OF TRADE.** User is responsible for determining whether the 3M product is fit for a particular purpose and suitable for user's application. If the 3M product is defective within the warranty period, your exclusive remedy and 3M's and seller's sole obligation will be, at 3M's option, to replace the product or refund the purchase price.

Limitation of Liability: Except where prohibited by law, 3M and seller will not be liable for any loss or damage arising from the 3M product, whether direct, indirect, special, incidental or consequential, regardless of the legal theory asserted, including warranty, contract, negligence or strict liability.



Customer Response Center

900 Bush Avenue 21-1W-10
St Paul, MN 55106
1-866-279-1235

3M, Brushlon, Doodlebug, Dual Lock, Finesse-It, Grit-lok, Hookit, Insta-Lok, Paint Buster, Perfect-it, Roloc, Roloc+, Roto Peen, Scotch-Brite, Stikit, Superbuff, Twist-lok and Wetordry, are all trademarks of 3M.

Printed in U.S.A.
© 3M 2006 All Rights Reserved
61-5002-8098-9