



OPERATION & PARTS MANUAL

LMV



Sharp Industries, Inc.
3501 Challenger Street
Torrance, CA 90503
(310) 370-5990 Fax: (542-6162)

www.sharp-industries.com

Wiring for Dual Voltage Motors:

WARNING: Disconnect all power source before changing any wires.

1. Most spindle motors are interchangeable between 220V and 440V. To change wiring, follow the instructions below.
2. After disconnecting the power, remove cover on the motor. The diagram below should appear on the inside. If in doubt about the electrical wiring, please consult a qualified electrician or Sharp Industries, Inc. for advice.
3. After making the connections as illustrated below, check that all connections are tight and properly isolated, then replace cover and apply power.

220 Volts

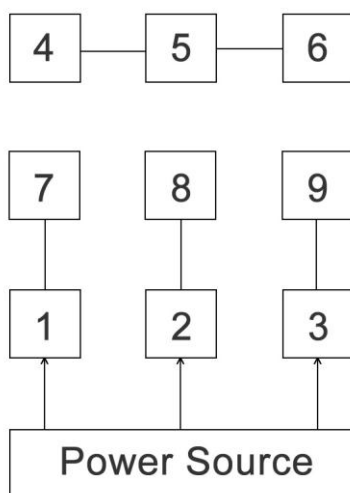

440 Volts

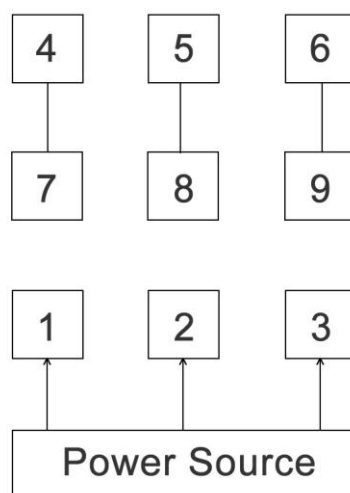

TWIN COOLING FAN WIRING DIAGRAM

CAUTION.....
Follow wiring
instruction
carefully!

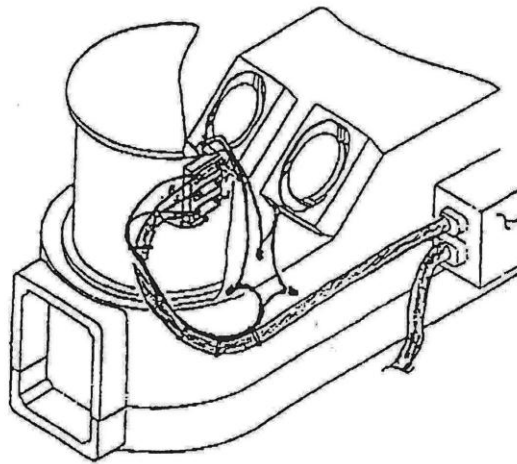

ACTUAL WIRING DIAGRAM FOR
TWIN 220V COOLING FANS

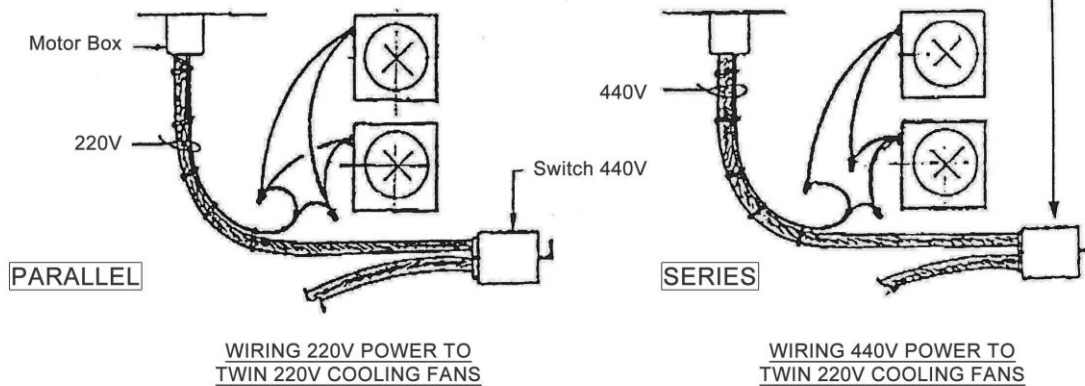

WIRING 220V POWER TO
TWIN 220V COOLING FANS

WIRING 440V POWER TO
TWIN 220V COOLING FANS

1. Warning: Disconnect power source before starting installation.
2. Caution: Follow wiring instruction carefully.
3. For trouble shooting, use a meter to check the current. Do not use the 440V current to check the fan individually.
4. This method of connecting the fans in series to run on 440V current is only applicable to the Twin Fan model. Do not use it on the Single Fan model.

CONTENTS

Forward.....	1
Safety Rules and Regulations	1
MODEL LMV VERTICAL VARIABLE SPEED MILL.....	2
Specifications	2
Uses.....	2
Machine Parts	3
Headstock Cooling System	7
Lubrication	8
 Operation Instructions:	
Headstock	10
Mill Body	15
Unpacking, Moving, and Floor Space.....	17
Alignment	21
Trouble Shooting	22
Maintenance	37
Feedrate Cutting Speeds	38
Remarks.....	39

1. Forward:

SHARP LMV milling machines are designed and manufactured to meet the demands of our customers. All parts and materials have been placed under strict quality control to ensure the superior quality and durability.

This manual gives a detailed account of the structure, mechanism, and methods of operation and maintenance of the LMV mill. To ensure the maximum performance and precision operation, it is imperative that operators, maintenance and repair personnel read the manual thoroughly and follow the specific instructions in operating and maintaining the machine.

2. Safety Rules and Regulations:

1. Do not wear loose clothing when operating the machine.
2. Operators shall wear goggles and safety boots.
3. Do not disturb the operator when the machine is running.
4. Caution should be taken when removing chips from work surface.

3. Notice:

Retrofitting the Sharp Mill with a CNC control, such as Sony, AcuTire, Anilam or other similar controls without the installation of an approved auto-lube system will void the warranty on that machine.

SHARP VARIABLE SPEED MILLING MACHINE



1. Specifications:

STANDARD						
SPECIFICATION	INCH	MM		SPECIFICATION	INCH	MM
WORK TABLE				Spindle speed	50HZ	50-3750 rpm
				RPM	60HZ	60-4500 rpm
Working area of table	42 x 9			Machine Net Weight		1.01 kg
Table Travel	30					
Saddle Travel	12					
Knee Travel	16					
HEAD						
Motor	2HP 3HP					
Spindle Taper	R8 or N.S.T # 30					
Quill Travel	5	127				
Feed Rate per Revolution	0.0015, 0.003, 0.006	0.04, 0.08, 0.15				
OPTIONAL						
Working Area of Table	49 x 9	1225 x 230	Table Travel (Head)	36%	933	

2. Machine uses:

1. Drilling
2. Milling
3. Molding
4. Polishing
5. Boring

3. Machine parts:

1. Headstock:

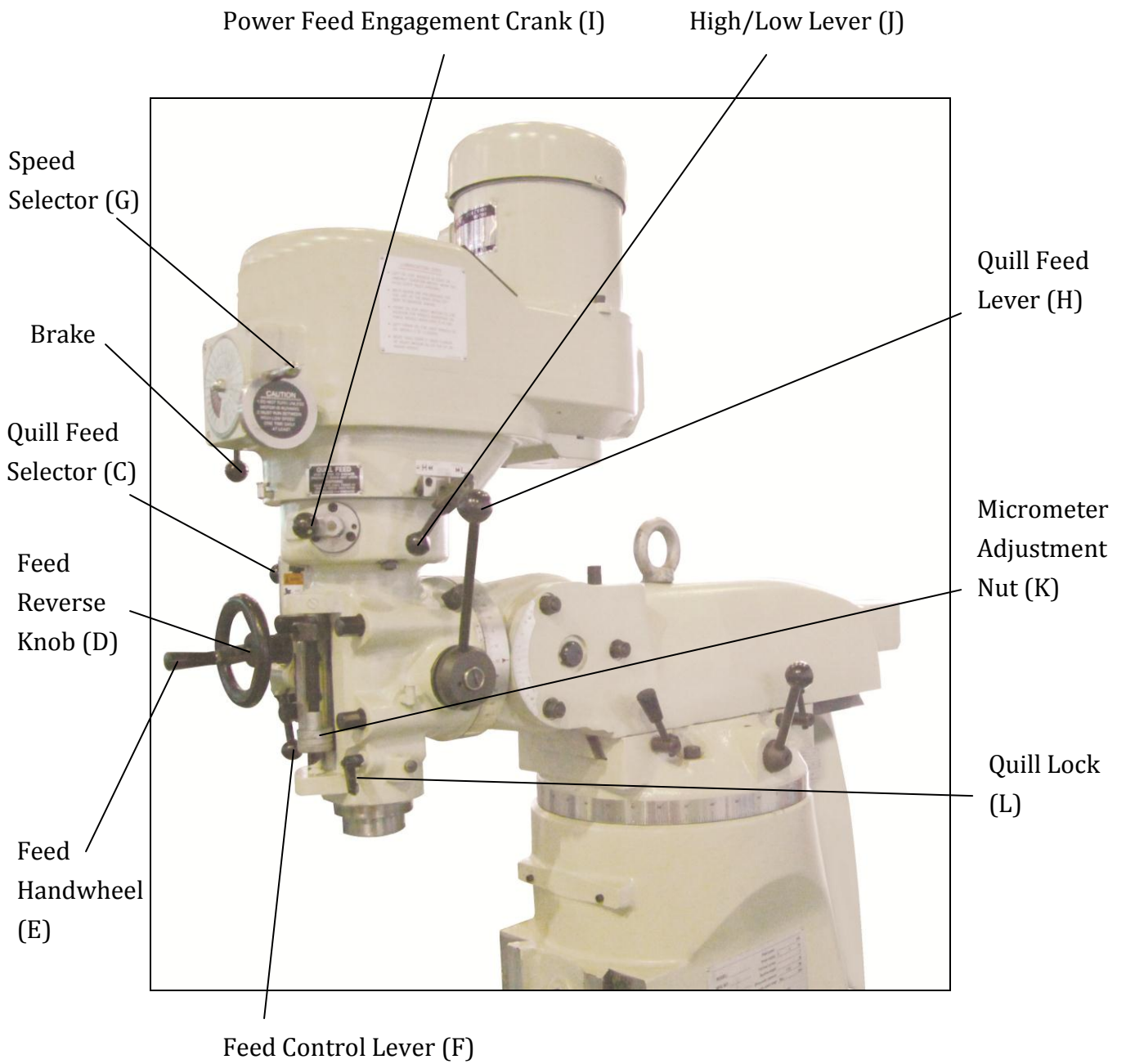

DVS HEAD

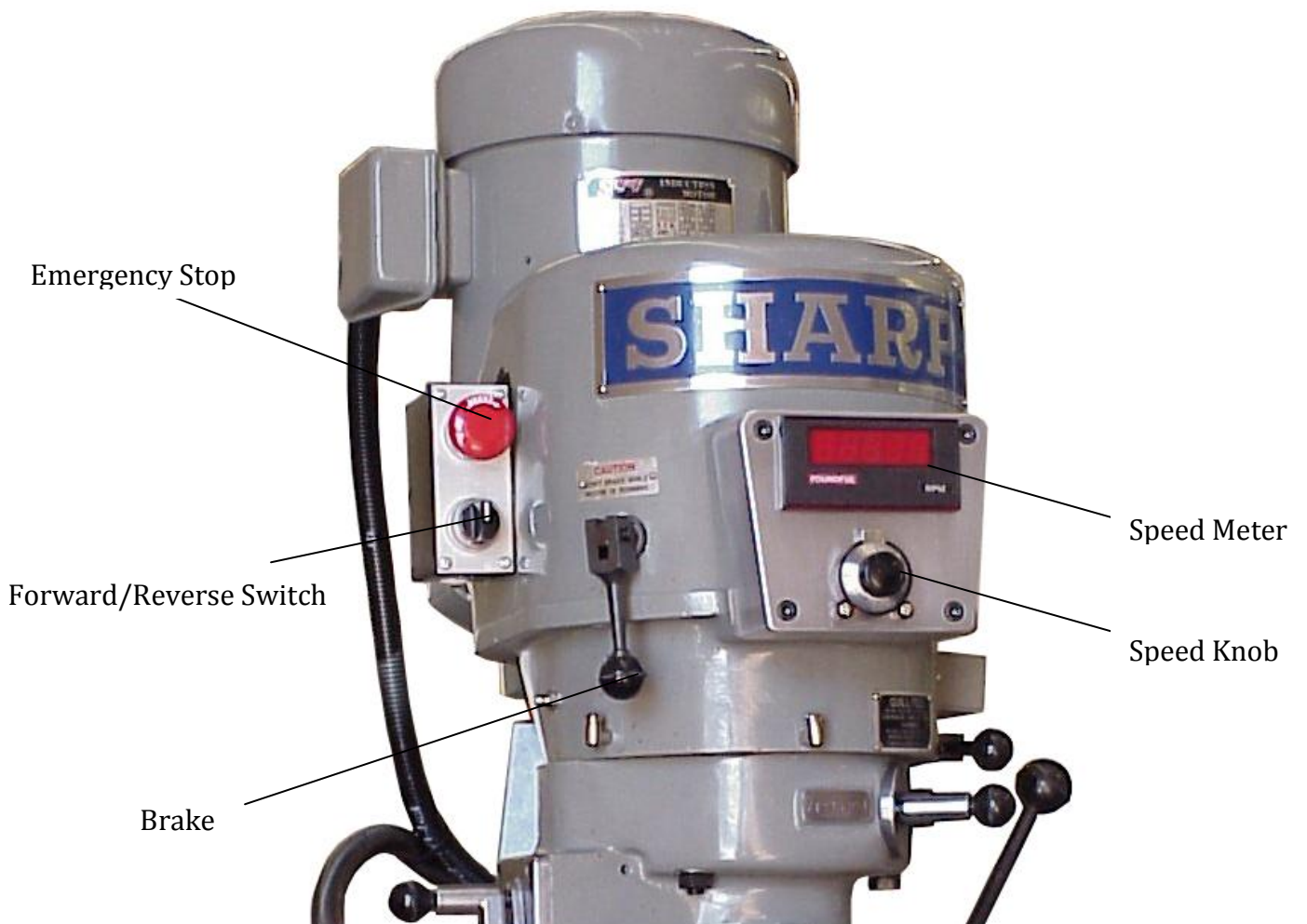

2. Machine Body:

1. Columns, Turret, and Ram:

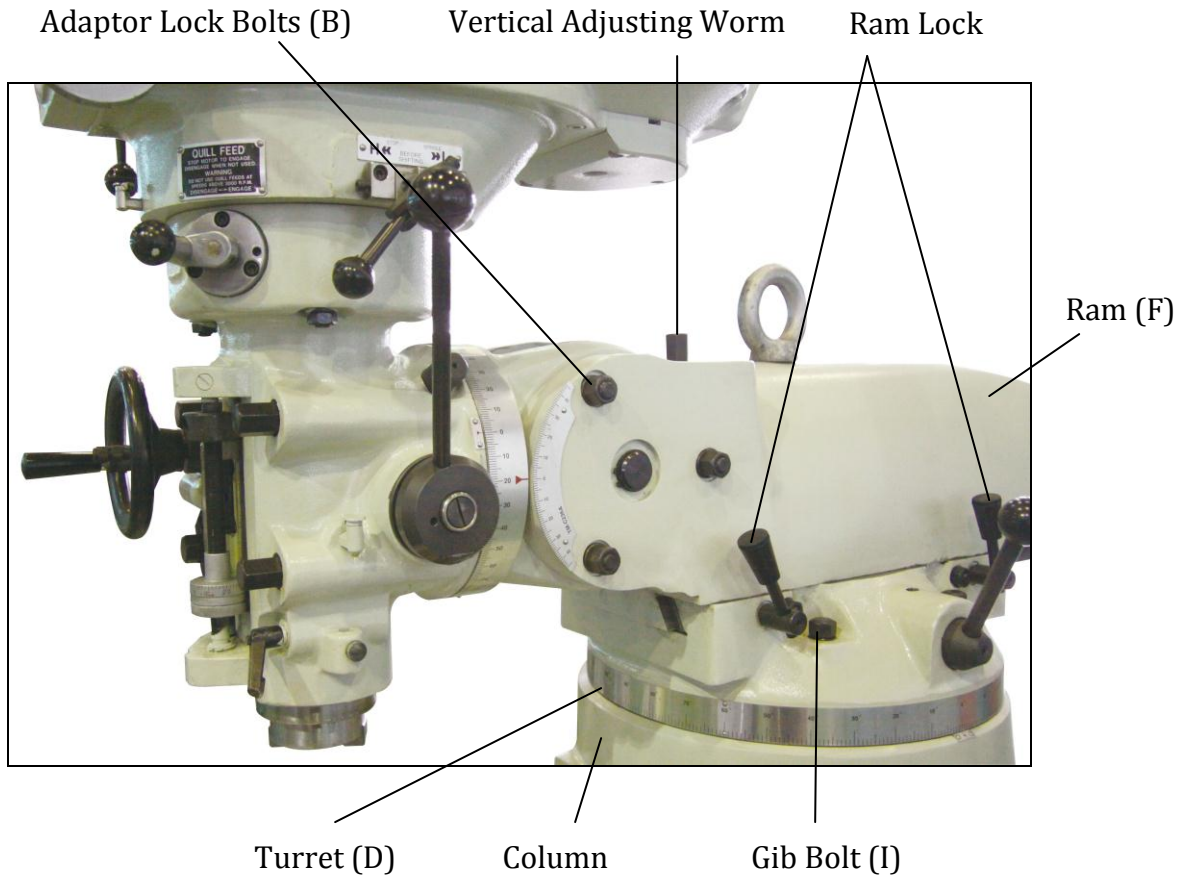

Figure 4

2. Tables, Saddle, and Knee:

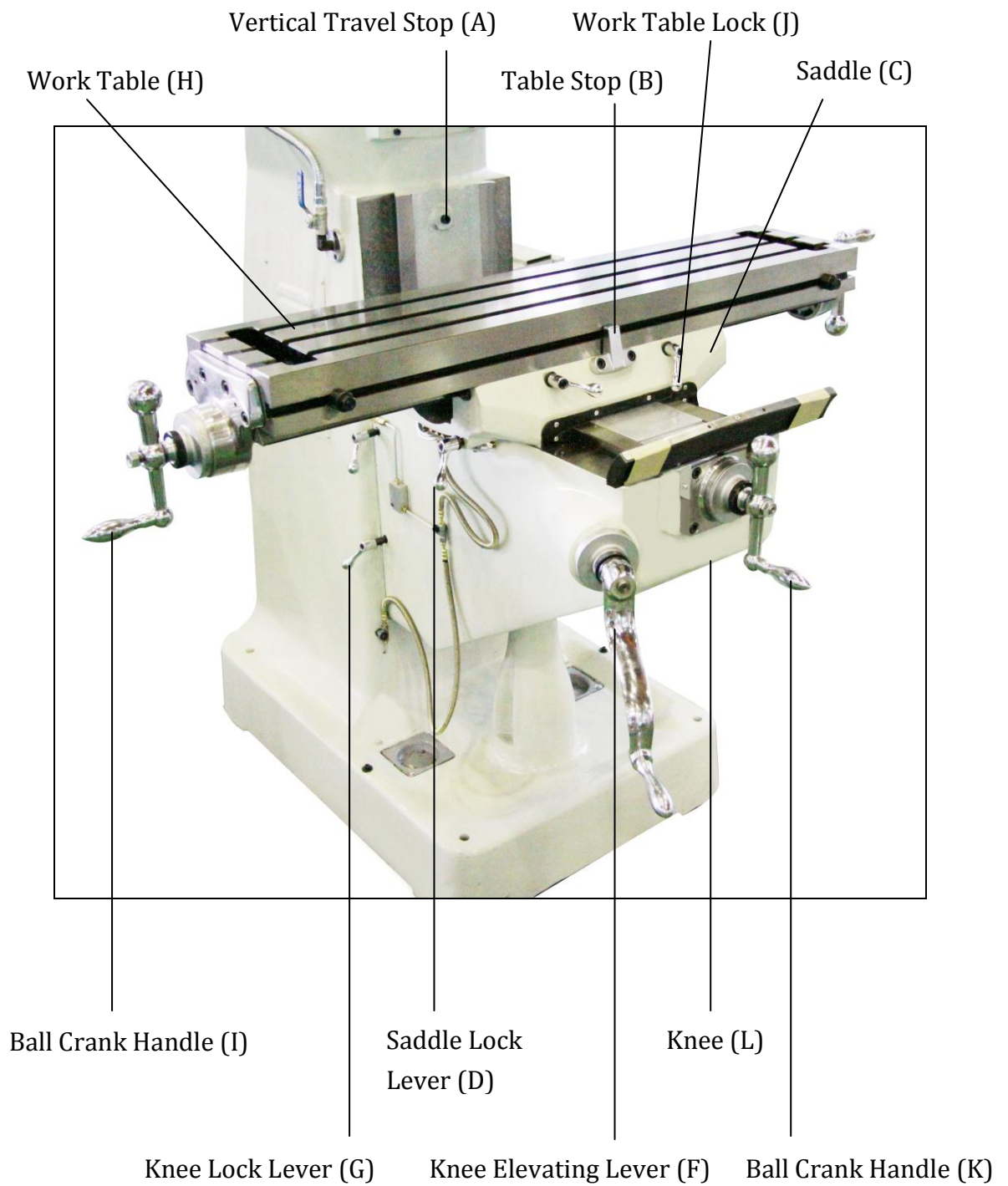

Figure 5

4. Headstock Cooling System:

The variable speed headstock is equipped with a unique cooling system. Two fans have been installed outside of the cover between the front and rear speed change wheels. The purpose of the fans are to dissipate the heat build up between the belt and the speed change wheel, and prolong the life of the mill.

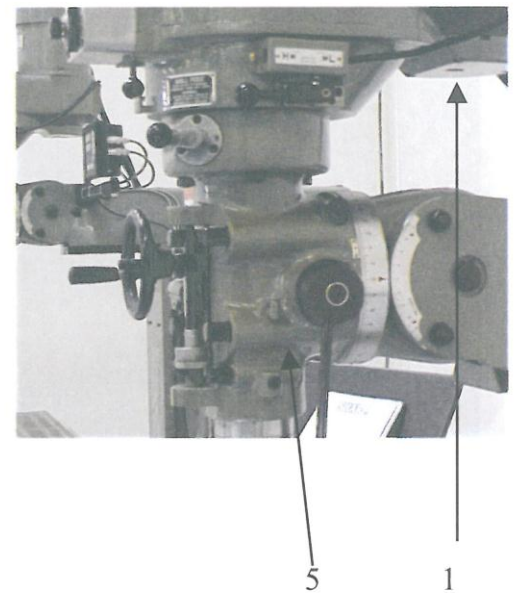
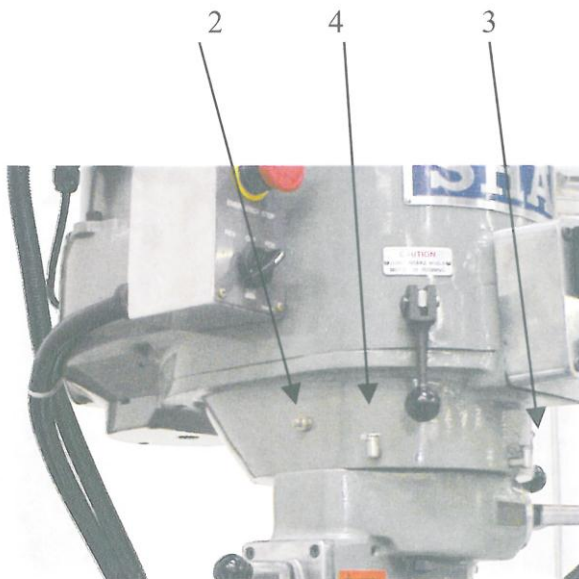

Figure 6

5. Lubrication:

1. Head:

Position	Type	Lubricant	Frequency	Function
1.	Grease	Shell Tonna 32	One Shot Every 3 Months	Motor Shaft
2.	Grease	Shell Tonna 32	As Needed **	Bull Gear
3.	Oil Cup	Shell Tonna 32	Twice a Week	Bull Gear Bearing Shaft
4.	Oil Cup	Shell Tonna 32	Daily	Worm Gear Cradle
5.	Oil Cup	Shell Tonna 32	Twice a Day	Quill



2. Table, Saddle, and Knee

Position	The ways, saddle, knee and leadscrews are oiled by means of a manually operated pump, located on the back side of knee.
Frequency	2 pumps 3 to 5 times daily
Lubricant	Shell Tonna 33



Figure 8

6. Operation:

1. Headstock:

- a. Power to the motor is controlled by a three way switch, forward, reverse, and off (Fig. 9). When the high-low speed change lever (Fig. 3 (J), Page 3) is in high gear position and the switch is in FOR., the spindle rotation is clockwise. When the switch is in REV., the rotation is counter clockwise.
- b. Spindle Brake:
To prevent damage and prolong the life of the brake, the power must be off and the spindle must be below 200 RPM before engaging brake. The brake can be engaged by pushing or pulling the brake lever (Fig. 10). Pulling the brake lever up after it is engaged can lock the brake.
Caution: Be sure the brake is in neutral before starting the spindle.
- c. Installation of Collet:
 1. Raise the spindle all the way up.
 2. Insert collet, being sure the keyway lines up with the pin in the spindle.
 3. To tighten, turn the drawbar clockwise while brake is engaged. To remove collet, loosen the drawbar (counter clockwise) three to five turns and tap the drawbar with a soft mallet to break the collet loose from the taper.

NOTE: When the mill is fitted with the R8 spindle, care must be taken that the collet keyway is aligned with the pin in the spindle (Fig. 36, page 35).

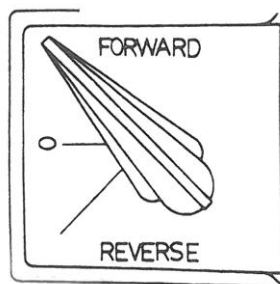

Figure 9

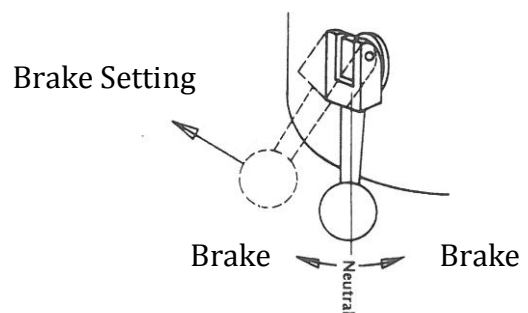

Figure 10

d. Manual Feed:

The manual feed lever is located on the right side of the headstock (Fig. 3 (H), Page 3). This lever controls the vertical movement of the spindle. For the operator's convenience the lever can be adjusted as needed.

Note: in manual feed, the feed control handle "F" (Fig. 11) must be in the "F1" position.

e. Manual Micro-feed:

To use the manual micro-feed, the power-feed transmission lever (J) (Fig. 11) must be placed at the "OUT" position, and the feed reverse knob (D) (Fig. 11) must be in the neutral position. To engage the overload clutch, lever "F" (Fig. 11) must be moved to the "F2" (Fig. 11). You can now turn handwheel "E" clockwise to lower the spindle, counter clockwise to raise it.

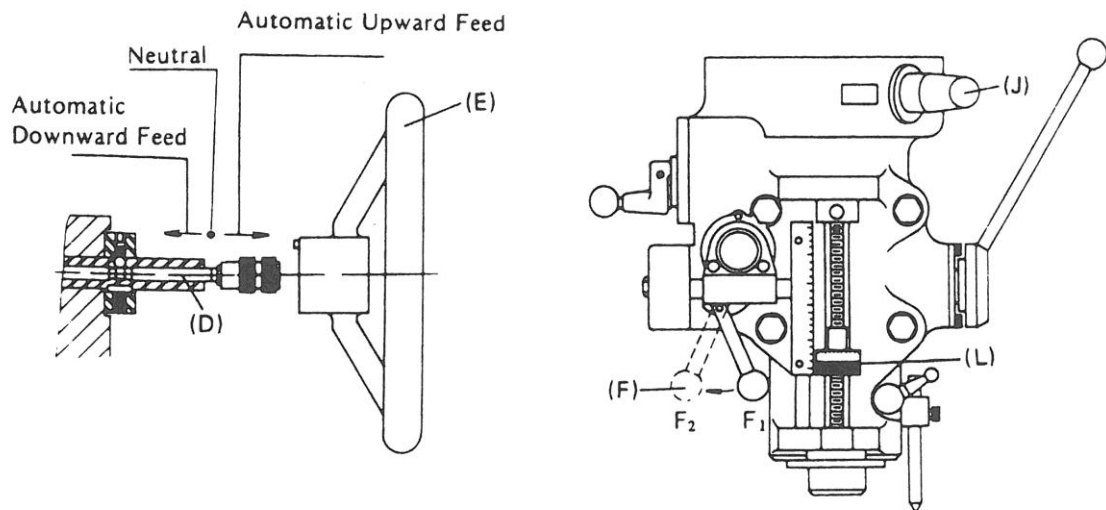

Figure 11

f. Automatic feed:

Procedure for using this function is:

- a. Loosen the quill lock "L" (Fig. 3, Page 3)
- b. Place the power feed transmission lever "T" (Fig. 3, page 3) in the "IN" position.
- c. Place feed speed lever "C" (Fig. 3, Page 3) in the desired position. (H, L, or M).
- d. To engage the overload clutch, place feed control lever "F" to the "F2" position (Fig. 12).
- e. The quill will move down when pressing knob "D" (Fig. 11) in, and pulling it out, the quill will go up (The middle is neutral).
- f. The working depth can be set by the use of micrometer adjustment nut "K" (Fig. 12). This adjusting nut is graduated in 0.001 and 0.02 mm increments. To activate the auto feed, pull the feed control lever "F" out. It will disengage when the adjusting nut contacts the quill stop block "I" (Fig. 12). For manual trip, you can push the feed control lever in manually.

Note:

1. Maximum drilling capacity for automatic feed is 3/8" or 10 mm.
2. The power feed transmission lever "T" (Fig. 3, Page 3) should be in the "OUT" position when the power feed is not being used. To avoid damage to the gears, **do not** engage the power feed when the spindle is running.

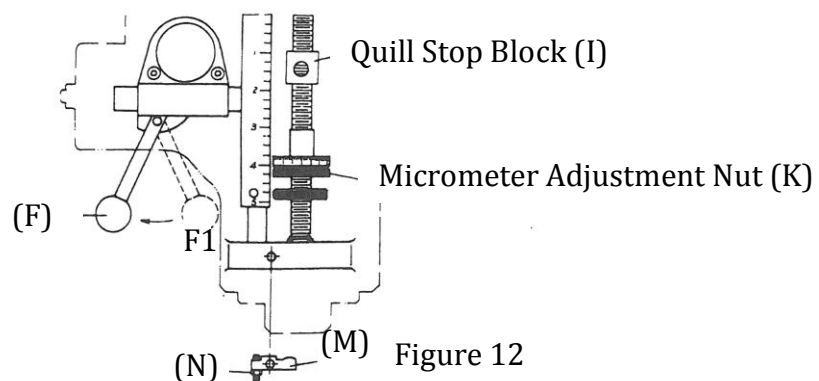

g. Spindle speed change:

The speed of spindle is controlled by a set of sliding belt pulleys and a counter shaft gear. There are two options (High and low). High gear is for RPM from 500 to 3,000 and low gear for RPM from 60 and 580. When high-low lever “J” (Fig. 13) is in the forward position it is in high gear, when facing back it is in low gear.

Note: To change from high to low:

- a. The spindle must be stopped.
 - b. Moving the spindle slightly by hand when shifting from high to low makes it easier for the gears to engage. You will feel a click when it engages.
 - c. The direction of the spindle is reversed when in low gear. This can be overcome by the use of “FOR” “REV” switch.
- h. Speed change handwheel:
- a. Do not change speed when spindle is stopped.
 - b. Do not run spindle in excess of 3,000 RPM.
 - c. Slow speed changes are advised, to prevent premature wear on the belt, pulley, and other internal parts.

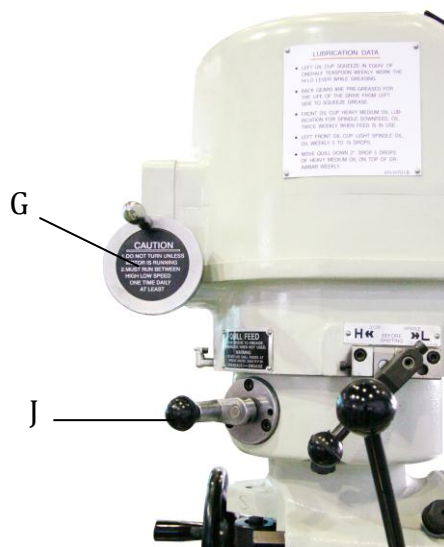

Figure 13

i. Tilting the headstock (Fig. 14):

To tilt the head up or down, evenly loosen the three adapter locking bolts (P) and move to desired angle using adjusting worm shaft "Q". Re-tighten the adapter bolts. NOTE: do not remove adapter bolts.

Cross tilting the headstock (Fig. 15):

Evenly loosen the four lock nuts "R". Using the worm shaft "S" move head to desired angle and retighten lock nuts.

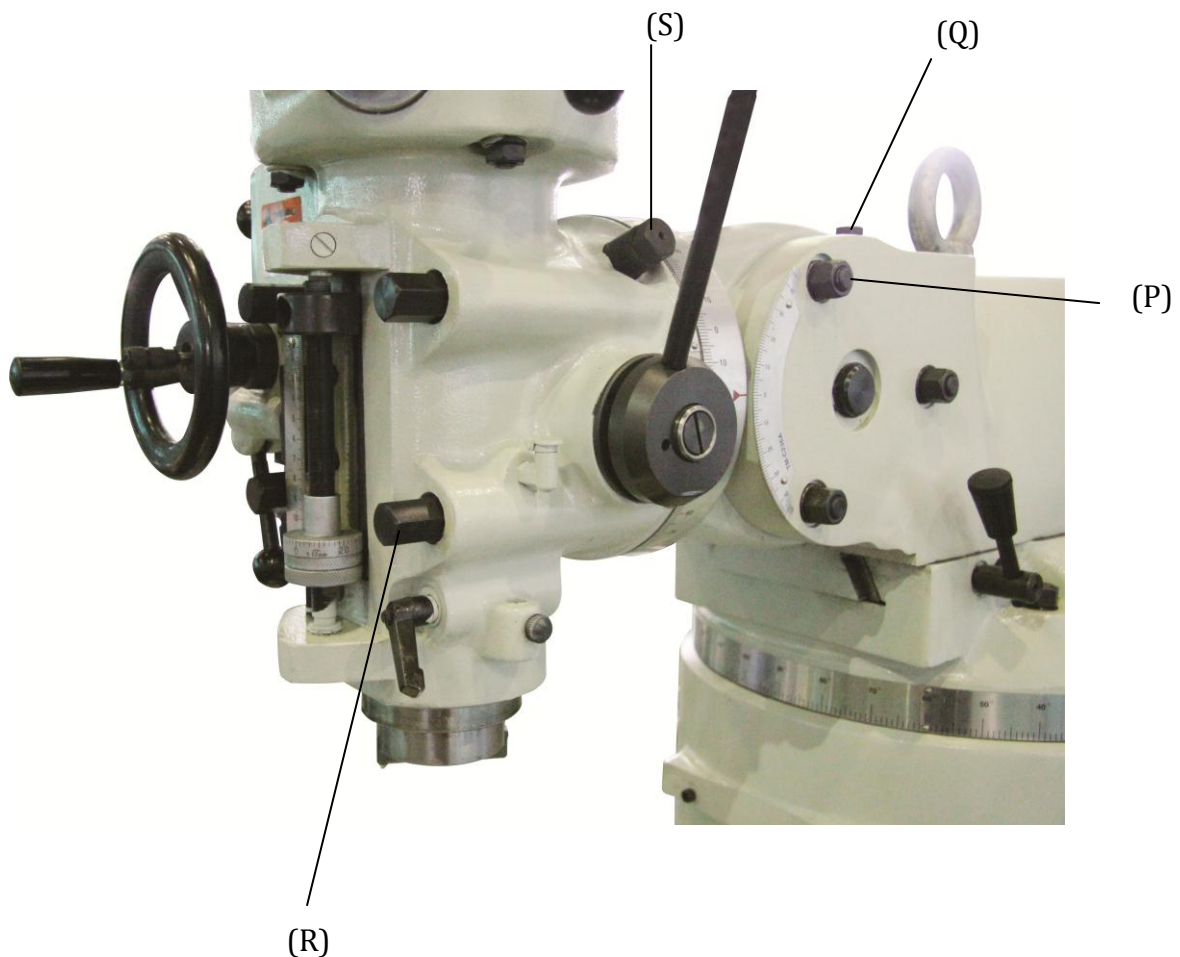

Figure 14 &15

2. Machine Body Operation:

1. Ram movement (Fig. 17):

- a. To move ram in or out, loosen Ram lock levers "A" and move to desired position using handle "B" and retighten levers.
- b. To swivel ram, loosen the four bolts "C", move to desired position and retighten bolts "C".

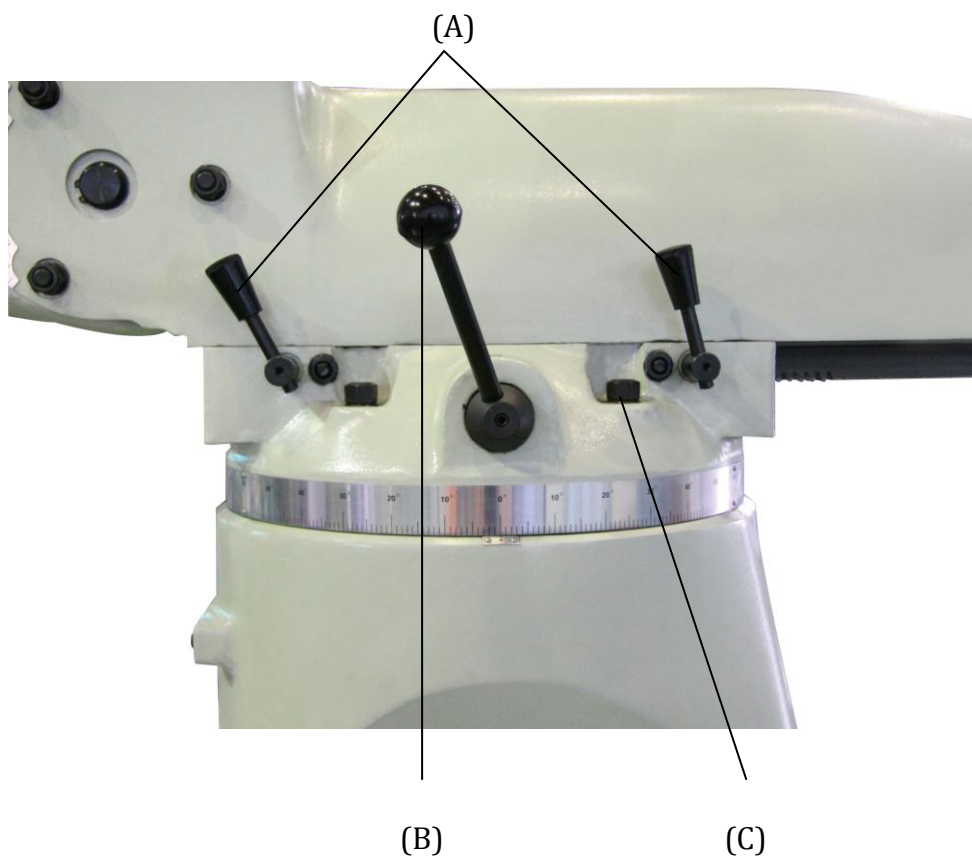

Figure 17

2. Setting handwheel dials to zero (Fig. 18):

- a. Loosen lock ring “D”.
- b. Turn dial “E” to zero and tighten lock ring “D”.

3. Locking the table, saddle, and knee:

To increase the stability of the mill and maintain a good workpiece finish, all non-feeding surfaces should be locked down. See Fig. 19 for location of locking levers.

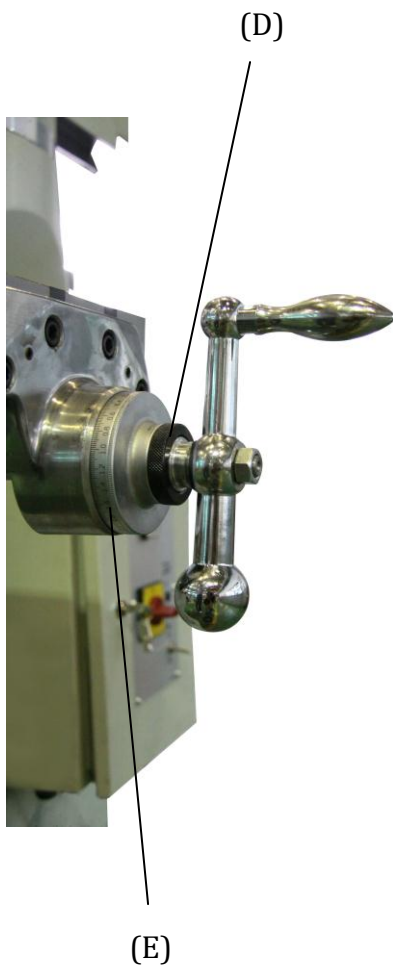
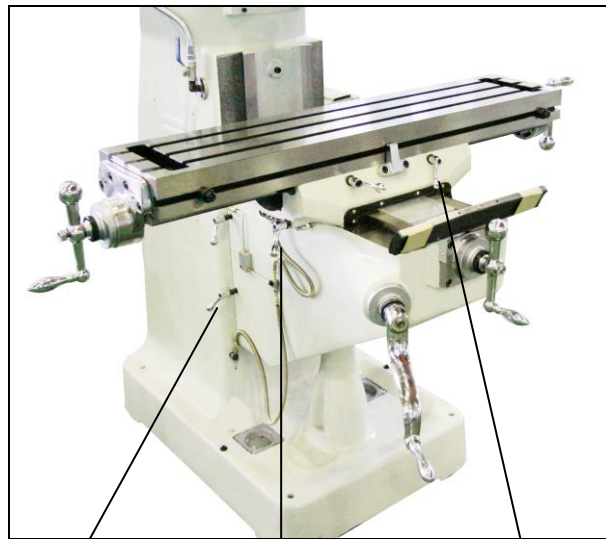

Figure 18



Knee Lock Lever

Saddle Lock
Lever

Work Table Lock
Lever

Figure 19

7. Unpacking, moving, and floor space:

a. Methods of moving machine:

1. Prior to unpacking or removing from skid, the machine should be moved by the use of a forklift or reinforced cable (Fig. 20 & 21).
2. Removal from the skid and any further movement of the machine should be done by the use of a reinforced cable or by the eye bolt located in the top of the ram.

Remarks:

1. When lifting or moving machine, be sure area is clear of all personnel.
2. Lifting machine by the use of eye bolt should be only when absolutely necessary.
3. When lifting or moving the machine before unpacking or removing from the skid, observe any precautions or instruction that may be printed on the crate.
4. The machine can be balanced while being moved by changing the location of table and or saddle.
5. Do not attempt to raise the machine too high. The recommended height is approximately 10 cm from the ground.
6. If the machine is not stable when being lifted, adjust the rigging as needed.
7. Only use qualified forklift operators to move the machine.



Figure 20

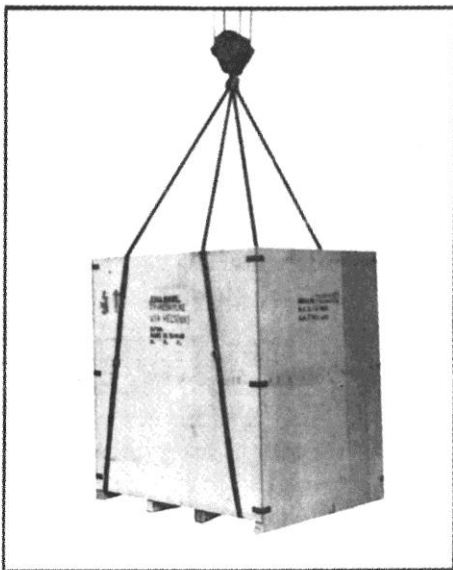

Figure 21

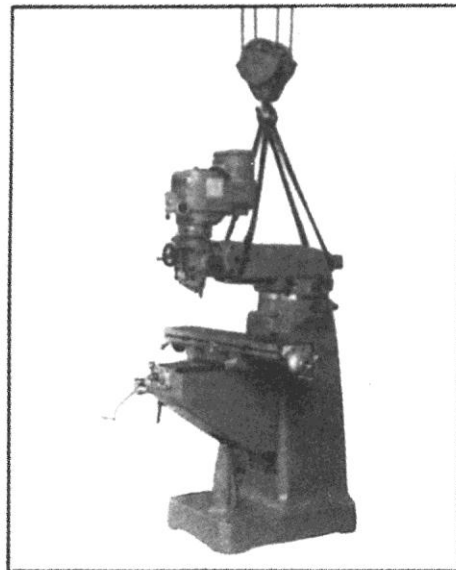

Figure 22

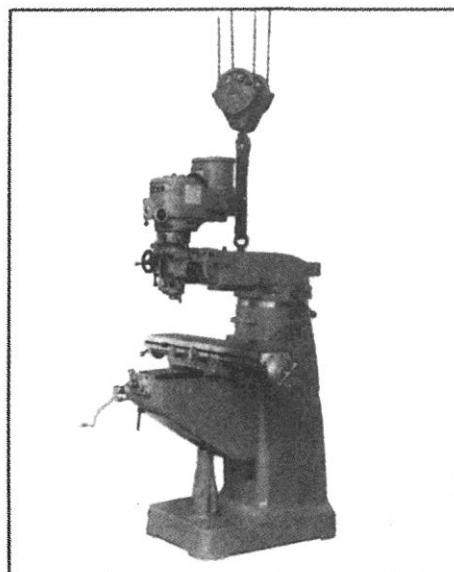
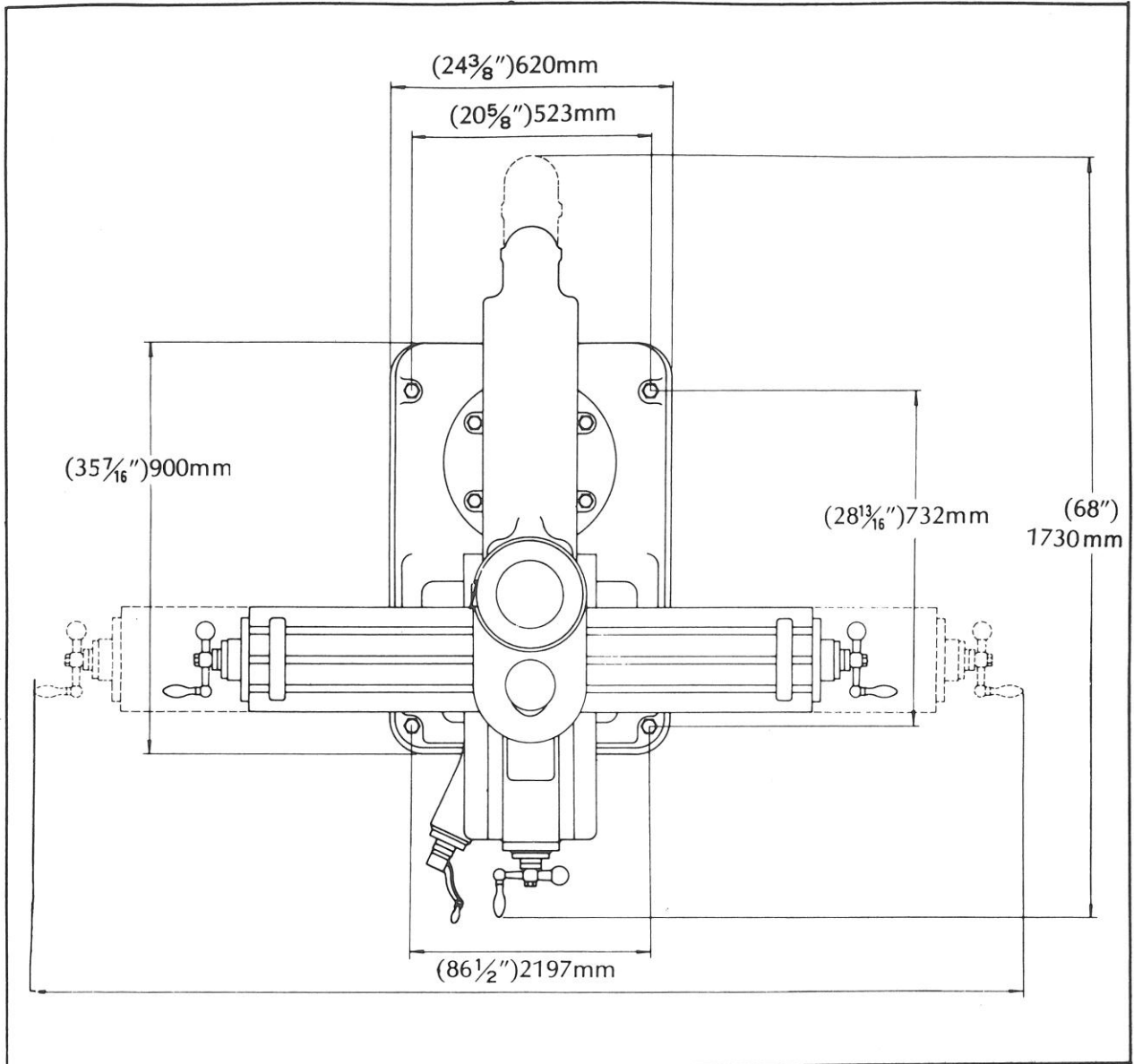

Figure 23

b. Unpacking:

1. To protect the machine while in transit it is necessary to cover it with a rust proof coating and a crate or plastic wrapping. In the event, there is damage due to moisture, please contact our agent or the transporter.
2. After unpacking, make sure all tools and accessories are intact. If not, contact our agent.
3. Restore headstock to its normal position (Fig. 3, Page 3)
4. Do not move the sliding surfaces until all of the protective rustproof coating is removed and all surfaces are well oiled.
5. Do not remove the oil wipers when cleaning the machine.
6. Do not use gasoline or other flammable cleaners.

(C) Floor Space:



(D) Machine Height: 2070 (81½'')

7. Machine Alignment:

Maintaining close tolerances and proper alignment of the machine is critical to producing quality-machining results.

Please see the following table of Precision Inspection.

Variable Speed Head Trouble shooting

Problem	Possible Cause	Solution
Consistent noise in both High and Low gear (Quiet in Neutral)	Upper and lower head not aligned Spindle spline and hub do not match	Align Replace either to match Replace H348 spindle bearing set or H349 top bearing if no chatter is present
Noise in High gear, Low gear & Neutral noise at all speed	Noise frequency follows the speed Noise frequency does not follow the speed	Replace spindle pulleys and H522 bearings. Replace motor bearings/ Motor
Noise in High gear only	Worn clutch Clutch out of adjustment	Replace H561 & H572 Adjust position of H/L lever
Noise in Low gear only	Bull gear Timing belt Timing pulley	Lubricate bull gear Hold brake & turn spindle by hand. If more than ¼ turn, replace timing belt. Replace bearing H301
Noise when quill is out	Twisted spindle Alignment of H & L head if noise Depends on position of spindle	Replace spindle Align head

Variable Speed Head Trouble shooting

Problem	Possible Cause	Solution
Intermittent Noise (Comes & goes) Noisy on first start up, goes away after 10 to 20 minutes	Drive belt stiff from sitting overnight	Normal
High pitch shriek when start up over 2,500 RPM	Motor shaft needs lubrication	Lubricate motor shaft (Do not over-grease. Excessive lubrication will cause belt to slip)
Vibration and noise in all speed and gears	H531 key too tight	Check key for proper clearance or replace
Noise in H/N/L at any speed, with a constant pitch	Worn or defective motor bearings	Replace motor bearings

Variable Speed Head Trouble shooting

Problem	Possible Cause	Solution
Auto Quill Feed does not work:		
Wheel responds to feed reverse knob nut does not feed	Damaged worm gear	Replace worm gear (H060) and check for alignment
Auto feed only works in one direction	Broken bevel gear	Replace bevel gear (H115 or H110)
Feed select does not engage	Broken gears	Inspect H102, H104, H126, H324, and H327 (Replace as needed)

8. Trouble Shooting:

1. Removing Motor (Fig. 25):

- a. While running motor reduce speed to 60 RPM. This will lower the stationary motor vari-disc to its lowest position.
- b. Temporarily disconnect the power source.
- c. Remove motor pulley cover “B” under the motor shaft, remove grease fitting. Use 2 of the screws to insert into the pulley spring washer/ plate “D”, taking care to tighten evenly.
- d. Connect the power and increase the RPM to 3,000, which will raise the motor vari-disc to gain access to the snap ring “G”.
- e. Disconnect the power.
- f. Remove snap ring “G”.
- g. Remove the two motor mounting bolts “H”. You can now remove the motor. (The lower pulley and spring assembly will slide out and remain in the housing.)
- h. Reverse above procedure to re-assemble.

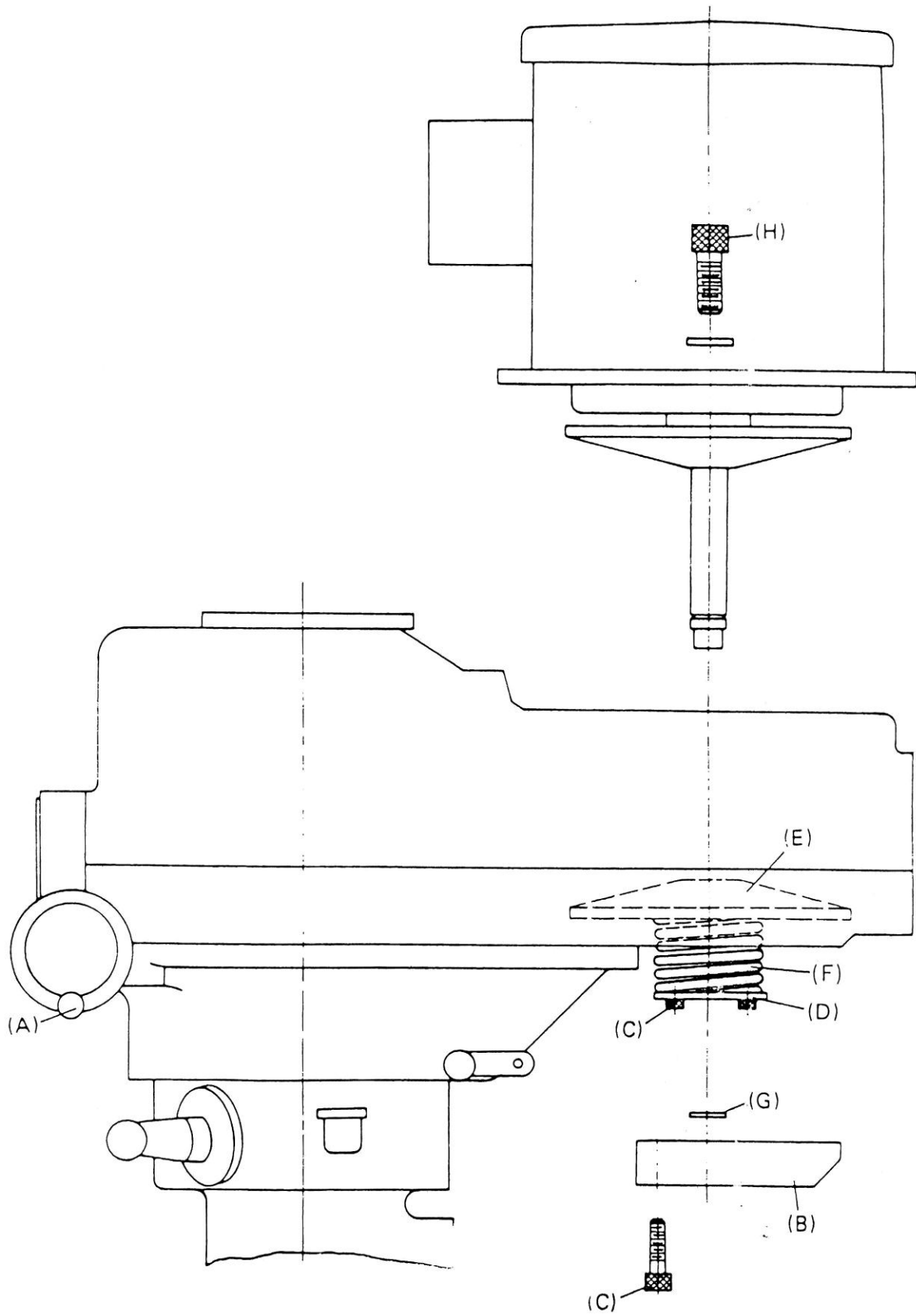

Figure 25

2. Replacing the Speed Change Belt

- a. Refer to steps a. to g. on page 24 for removing motor.
- b. Remove drawbar.
- c. Remove bolts “J” from bearing housing “K”. Use 2 of the bolts to push housing off of the housing “T”.
- d. Remove the 2 bolts “L” and sleeves “M” that hold the speed change plate.
- e. Remove “N”, “O”, and “P” (Total of 6 bolts).
- f. Remove the 2 lower bolts “S” on the speed change housing “Q”.
- g. Separate the upper housing “T” because the housings are pinned together, it may be necessary to use a soft mallet to separate them.
- h. After replacing the belt, reverse the above order to re-assemble.

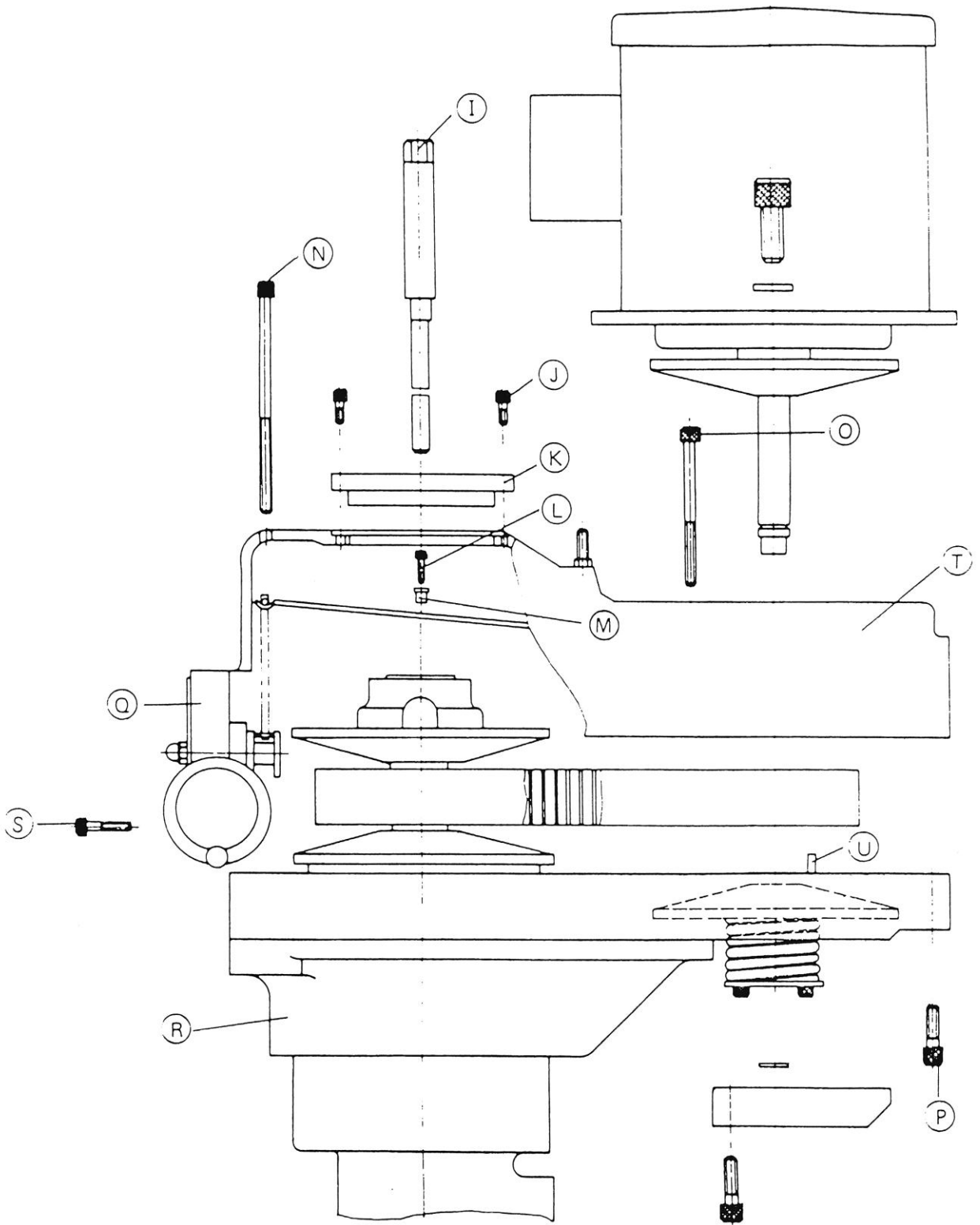

Figure 26

3. Brake Block Replacement (Fig. 27):

- a. Refer to steps a. to g. on page 24 and steps b. to g. on page 26.
- b. Remove the four bolts “V” (Fig. 28) so housing “T1” can be removed. It may be necessary to use a soft mallet. (Housing “T1” and “R” are pinned together).
- c. Remove vari-disk assembly set “E1” (Fig. 27) by removing bolt “X”. Brake block “Y” can now be replaced.
- d. Reverse above order to re-assemble.

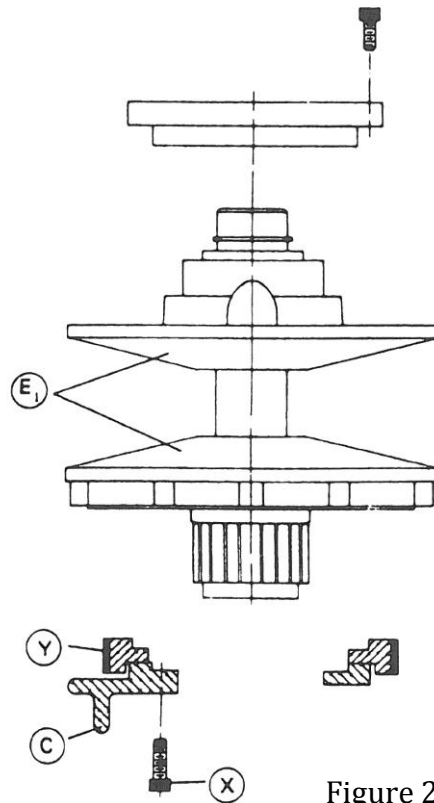

Figure 27

4. Replacing Timing Belt:

- a. Follow disassembling procedures outlined in steps a. to g. on page 24 and steps b. to g. on page 26 and steps b. on page 28.
- b. Change the timing belt as shown in Fig. 28.
- c. Reverse above order to re-assemble.

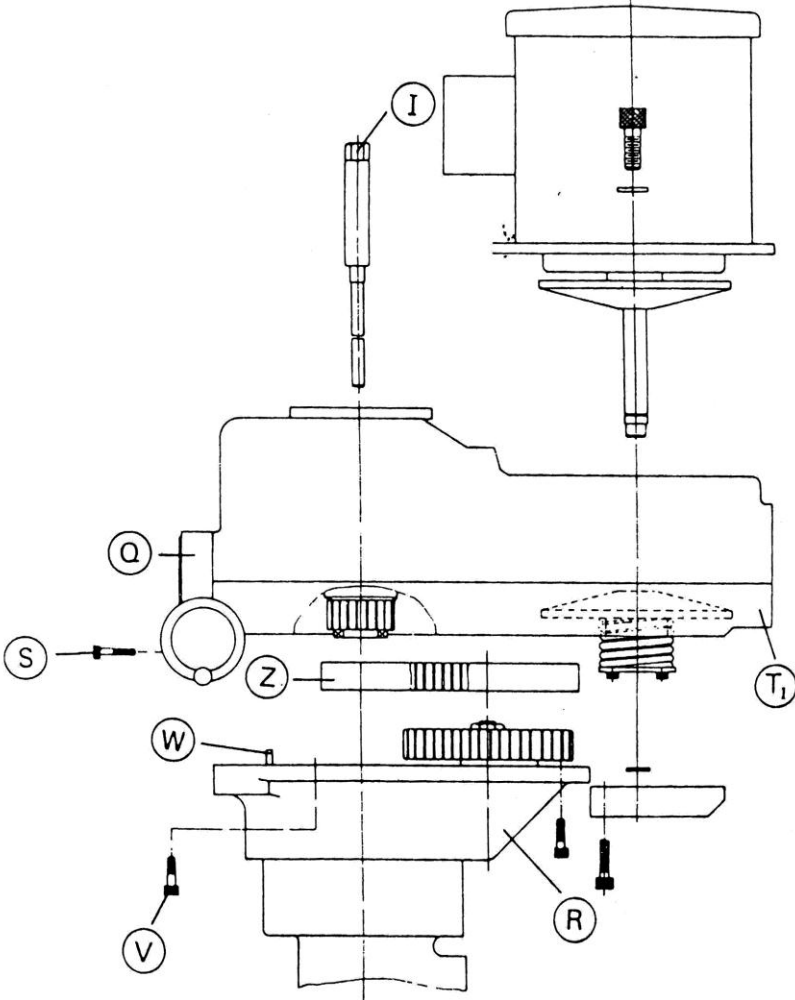

Figure 28

5. Adjusting leadscrew backlash:

A. Y-axis backlash adjustment:

- a. Move saddle to the middle of its travel.
- b. Remove 4 bolts "I" on bearing bracket "G".
- c. Lock saddle and turn hand crank "F" clockwise to separate bracket "G" from the knee.
- d. Unlock saddle and move screw until adjusting tool fits into the space.
- e. Use the large end of the tool to loosen the lock nut "J" (Counter clockwise).
- f. Turn adjusting nut "K" with the small end of the tool to reduce backlash (Counter clockwise).
- g. Using the large end of the tool, tighten lock nut "J".
- h. To re-assemble, turn hand crank "F" counter clockwise to seat.

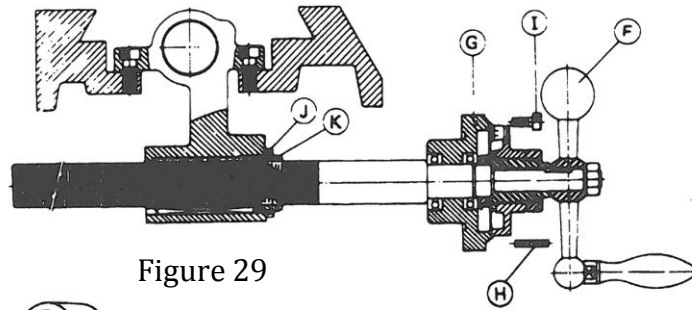

Figure 29

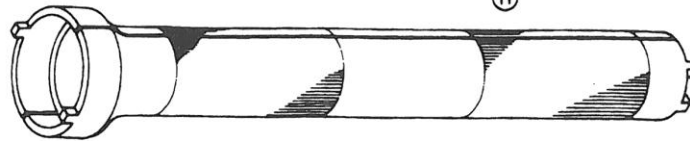

Figure 30

Bracket "G" to the knee, being careful to align the pins and replace bolts "I" to complete the process.

Resulting backlash should be 0.003 to 0.004

B. X axis backlash adjustment;

- a. Move the work table to the center of the saddle.
- b. Insert large end of adjusting tool into the left side of the saddle and turn lock nut “J” counter clockwise approximately one turn.
- c. Using small end of tool tighten adjusting nut “K”.
- d. After adjusting nut “K”, use large end of tool to re-tighten lock nut “J”.

Resulting backlash should be 0.003 to 0.004

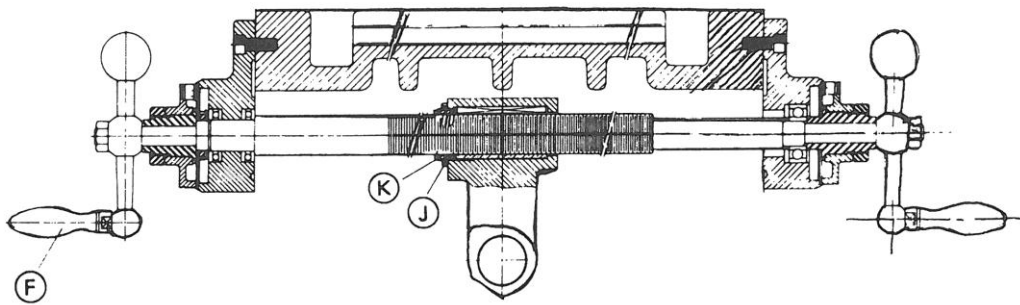

Figure 31

6. Adjusting Gibs:

After a period of time the gibs may become loose or worn and may need to be adjusted to maintain the integrity of the mill.

A. Table Gib (Fig. 32):

The table gib is located between the saddle seat and the table dovetail.

- a. Loosen lock levers "L".
- b. Clean and lubricate slideways.
- c. Using a screwdriver to adjust the gib screws "M" located on both sides of the saddle. If moving the table and screws turn loose, they can be adjusted by:

Slightly loosen the adjusting screw on the right, then tighten the left screw. After adjusting, check movement of table. If still loose, repeat the process until desired fit is obtained.

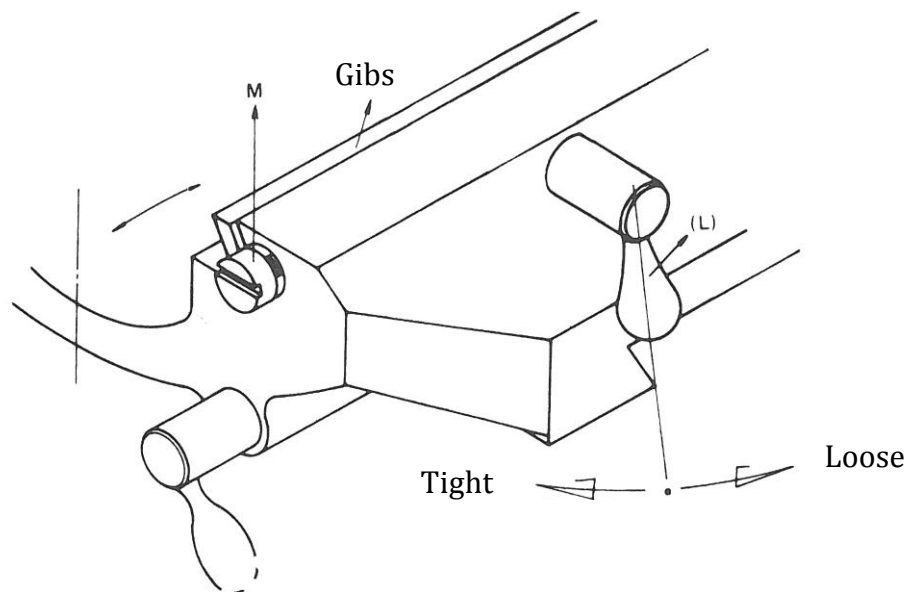

Figure 32

B. Saddle Gib (Fig. 33)

The saddle gib is located between the left side of the saddle and knee dovetail, and it can be adjusted as follows:

- a. Loosen saddle lock "A".
- b. Move saddle to the front of knee.
- c. Remove wiper holder "B" on saddle.
- d. Clean and lubricate sideways.
- e. Adjusting gib using the same method used on table.
- f. After adjusting, replace wiper holder "B".

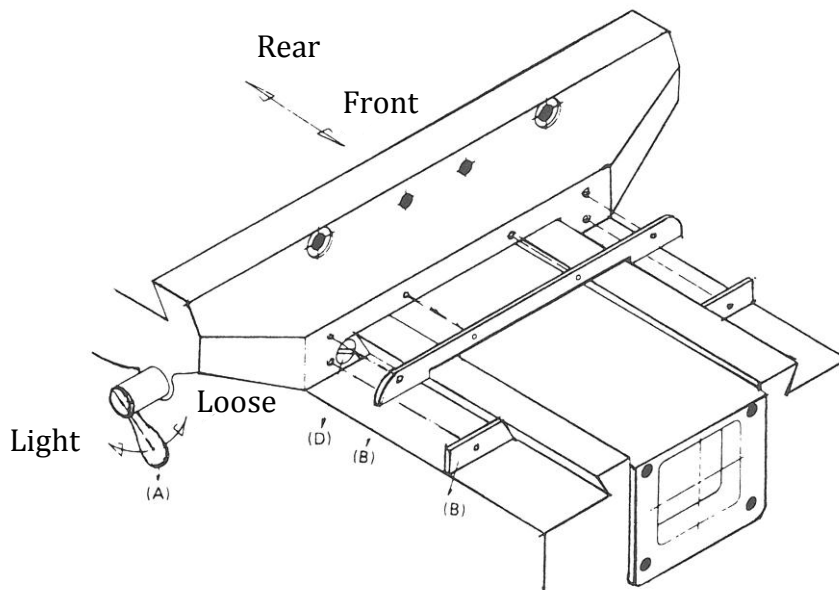

Figure 33

C. Knee Gib (Fig. 34)

The knee gib is located between the left side of knee and column dovetail, and it can be adjusted as follows:

- a. Loosen knee clamp (Fig. 5, Page 5).
- b. Remove wiper holder “Q”.
- c. Clean and lubricate sideways.
- d. Raise knee to its uppermost position.
- e. Adjusting gib screw “R” using the same method used on table.
- f. After adjusting, replace wiper holder “Q”.

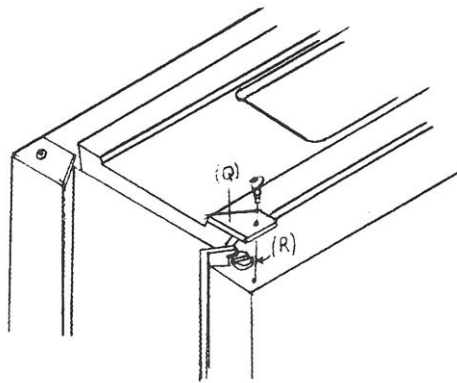

Figure 34

D. Ram Gib (Fig. 35):

The ram gib is located between ram and turret dovetail.

- a. Loosen ram lock lever “C”.
- b. Clean and lubricate slideways.
- c. Loosen lock nuts on gib adjusting screw “T”, adjust gib and retighten lock nuts.



Figure 35

(I) (C)

E. Collet Alignment Screw Replacement:

- a. First mark the location of nose piece "B" to its position to quill "A".
- b. Remove set screw "C" located on nose piece. Remove nose piece by inserting an adjustable spanner in two holes in the bottom of nose piece.
- c. Remove set screw "D", insert a collet in the spindle and adjust set screw "D". First, screw it in until it contacts the collet, then back it off approximately $\frac{1}{4}$ turn to allow 0.25 mm (0.01") play.
- d. If collet fits properly, replace set screw "D" and replace nose piece. Be sure to tighten so that the mark made in step "a" line up.

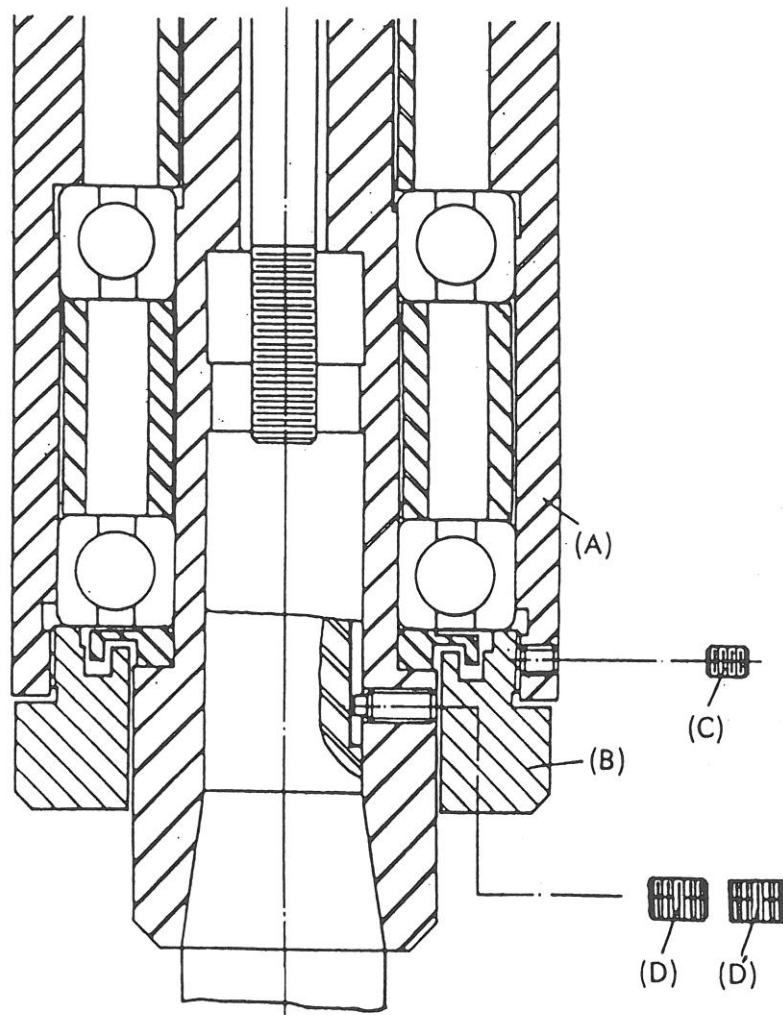

Figure 36

10. Maintenance

“Maintenance is more important than repair, and repair is better than purchase.”

The life of a machine can be greatly reduced if it has been properly maintained and operated. The result will be premature wear, inability to hold tolerance and poor finish on the workpiece. It is essential that operator be familiar with the operation and maintenance of the machine.

Daily Maintenance:

1. Check oil level in the pump (Manual).
2. Lubricate machine per lubrication charts on page 7 & 8.
3. Run machine at 1,200 RPM for 2 to 3 min. prior to operation. This is to allow the belt to stabilize.
4. At the close of each day:
 - a. Workpiece should be removed, (if practical) and work table should be cleaned and oiled.
 - b. All machine locks should be loosened and sliding parts lubricated. If practical, remove cutter.
 - c. Headstock should be returned to its normal position if it has been operated in a tilted position.

Monthly Maintenance:

- a. Check all clamping rails and sliding surfaces for wear.
- b. Check leadscrew backlash (Adjust if needed).
- c. Check quill lock and other moving parts for proper operation.

Quarterly Maintenance:

- a. Check brake and belt.
- b. Check if table is square with the head.
- c. Do a general test on machine, check for worn parts and replace as needed.

11. Notice:

1. Machine Operation:

- a. Machine must be installed on a solid base.
- b. Be sure the machine base and surface have proper contact before tightening anchor bolts.
- c. Be sure motor voltage conforms to the source voltage and properly grounded.
- d. Turn off machine before changing gears.
- e. Be sure cutter or tool is clear of the workpiece before starting or stopping the machine.

2. Machine Operator:

- a. Only authorized personnel should operate mill.
- b. If a problem is suspected, stop mill immediately, check for the problem, and make any repair or adjustment that maybe required.
- c. Auto feed lever must be in neutral before starting mill.
- d. Stop machine when inspecting tool or workpiece.
- e. Be certain that workpiece is properly clamped prior machining.
- f. Spindle must be kept clean and lubricated at all times.
- g. Keep tools and other objects off of table to eliminate damage or nicks.
- h. Make sure spindle is up to speed before starting the machining operation.
- i. Use a brush to remove chips.

PARTS

LIST

DVS HEAD PARTS 1

KEY	PART NUMBER	DESCRIPTION	QUANTITY
1	H-014	SHIFT CRANK	1
2	H-097	GEAR SHIFT PLUNGER	2
3	H-262	COMPRESSION SPRING	2
4	H-284	BLACK PLASTIC BALL	3
5	H-502	GEAR HOUSING	1
6	H-504	BELT HOUSING (BOTTOM)	1
7	H-505	BELT HOUSING (UPPER)	1
8	H-727	RPM DISPLAY HOUSING	1
9	H-728	SWITCH HOUSING	1
10	H-729	HOUSING PLATE	1
11			
12			
13	E-22S38B-EVS	FORWARD REVERSE SWITCH	1
14	E-22EB4R	EMERGENCY STOP SWITCH	1
15	RPM-0000	RPM DISPLAY INDICATOR	1
16	RPM-0-10	RPM DIAL	1
17	18CV-H011	SWITCH HOUSING	1
18	18CV-H011	SWITCH PLATE	1
19			
20			
21			
22			
23	D-150D-B	LIMIT SWITCH	1
24	A-33	“V” BELT	1

DVS HEAD PARTS 1

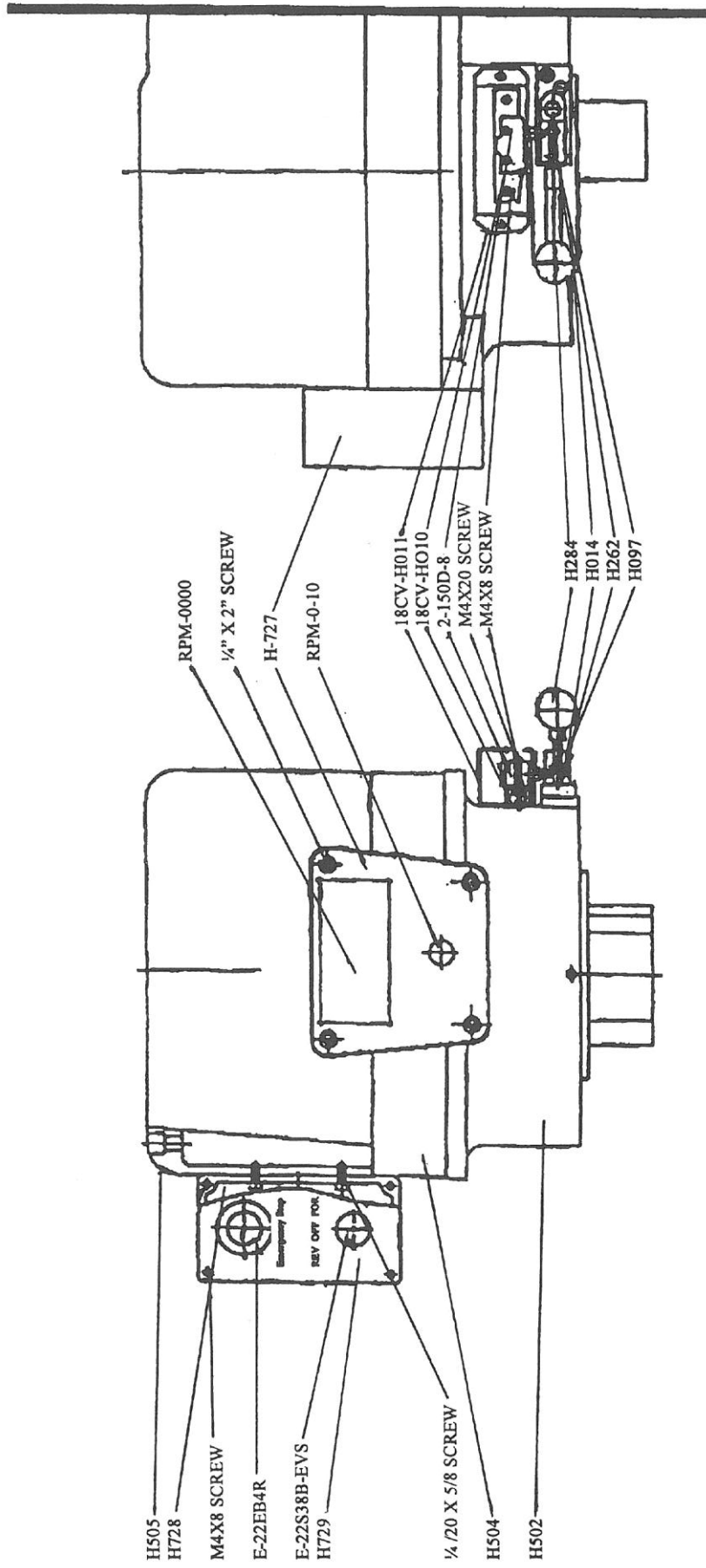

KEY	PART NUMBER	DESCRIPTION	QUANTITY
1	H-149	DRAWBAR WASHER	1
2	H-250	SOCKET SET SCREW	1
3	H-290	BEARING LOCK NUT	1
4	H-291	LOCK WASHER	1
5	H-505	BELT HOUSING (UPPER)	1
6	H-515	TOP BEARING CAP	1
7	H-516	WAVE WASHER	1
8	H-517	BALL BEARING	1
9	H-522	BALL BEARING	1
10	H-527	KEY	1
11	H-528	MOTOR	1
12	H-529	HEX HEAD SCREW	2
13	H-530	SPRING WASHER	1
14	H-541	DRAWBAR VARIABLE SPEED	1
15	H-544	BRAKE BEARING CAP	1
16	H-559	KEY	1
17	H-658	COVER	2
18	H-669	REAR COVER	1
19	H-722	SPINDLE PULLEY	1
20	H-723	MOTOR PULLEY	1
21	H-727	RPM DISPLAY HOUSING	1
22	RPM-0000	RPM DISPLAY INDICATOR	1
23			
24			
25	RPM-0-10	RPM DIAL	1
26	A-33	"V" BELT	1

DVS HEAD PARTS 2

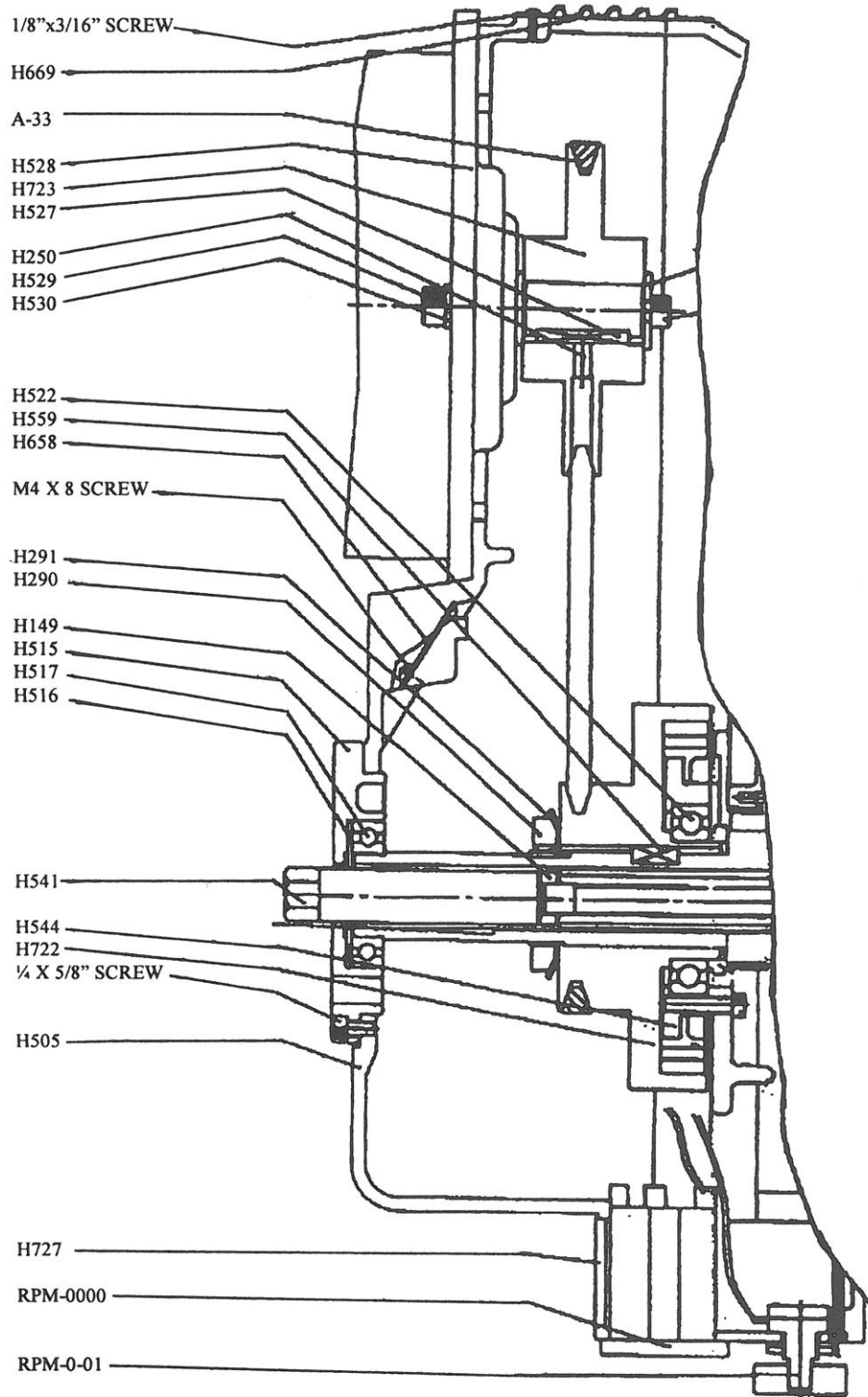

No.	Initial Setting	Current Setting	No.	Initial Setting	Current Setting
1	1	4	32	6	
2	0	1	33	100	
3	0	1	34	0	10
4	0	2	35	0	
5	0		36	3	8
6	0		37	0	1
7	0		38	8	
8	0		50	1	
9	0		51	2	
10	0		52	3	
11	60	102.0	53	5	
12	200	220	54	6	
13	60	60	55	7	
14	1.5		56	10	
15	12		57	0	
16	1.5		58	1	
17	12		59	2	
18	0		60	100	
19	10	2	61	0	
20	10	3	62	0.1	
21	10		65	0	
22	10		66	0	
23	0		67	1	
24	6		68	100	1.03
25	0		69	0	
26	0		99	0	
27	0		100	1.0	
28	0		103	3	1.2
29	0		105	3	
30	0		106	3	
31	0		107	3	

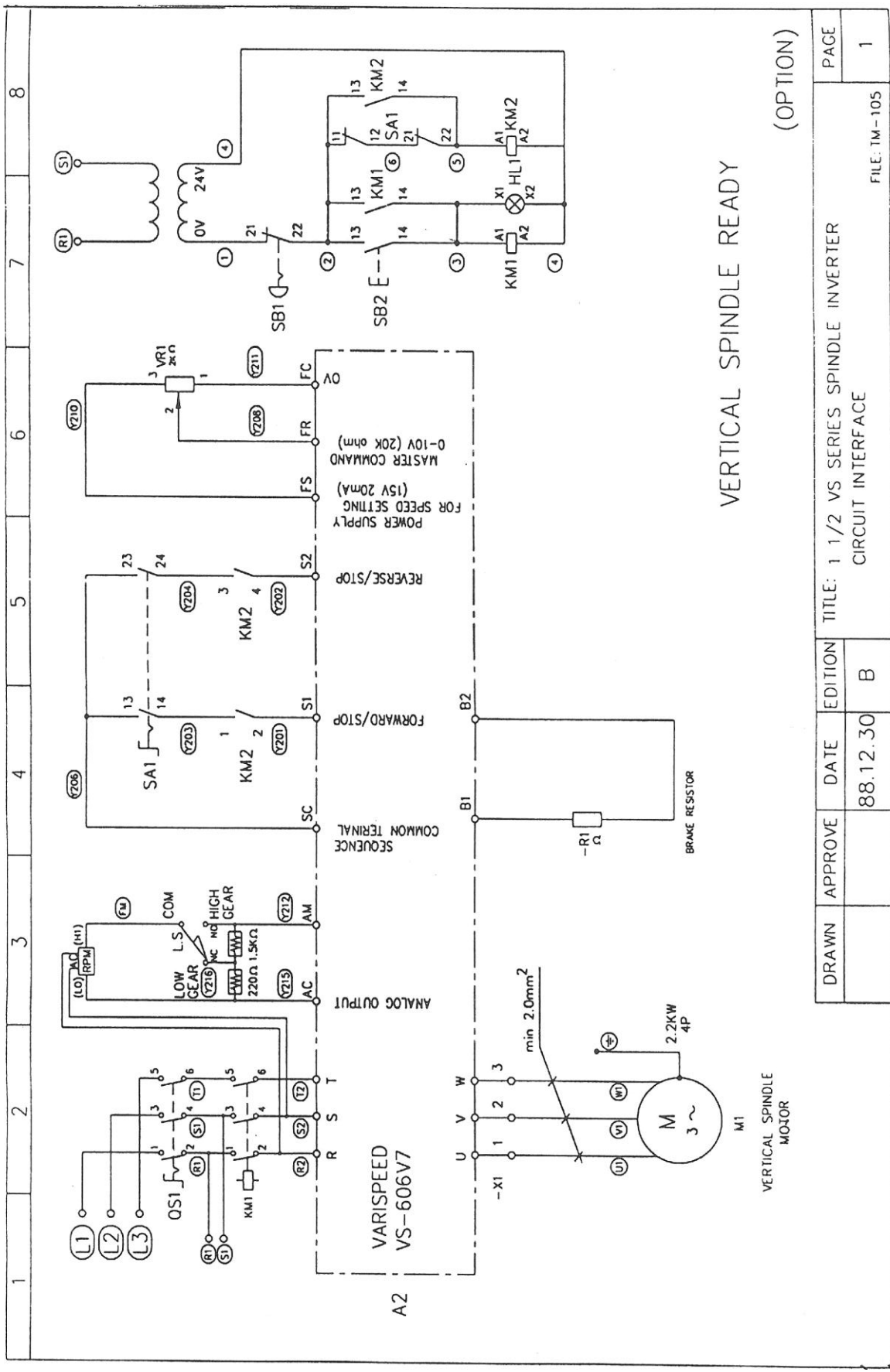

VERTICAL SPINDLE READY
(OPTION)

DRAWN	APPROVE	DATE	EDITION
		88.12.30	B

TITLE: 1 1/2 VS SERIES SPINDLE INVERTER CIRCUIT INTERFACE	PAGE
	1

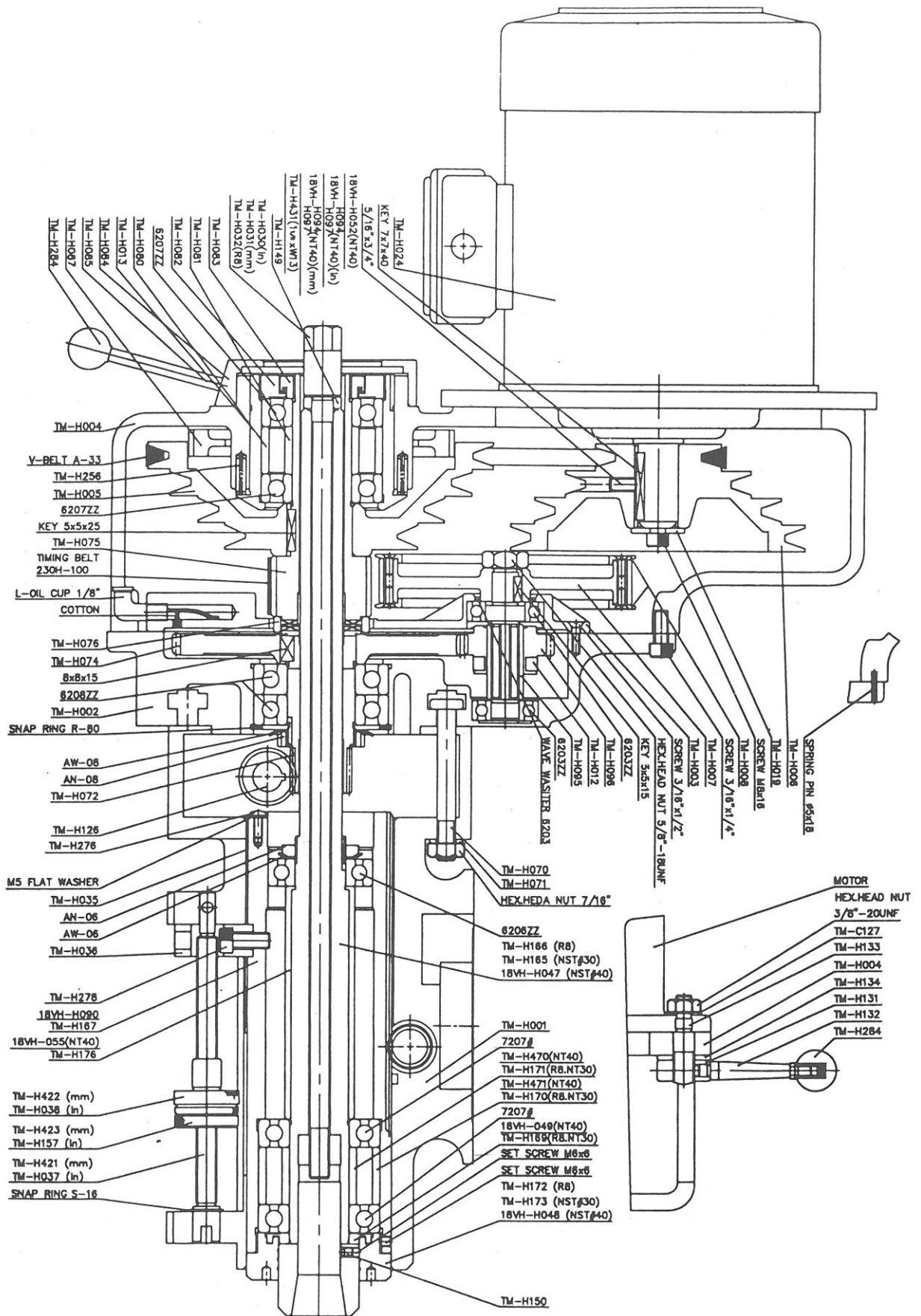

PARTS NO.		PC	DESCRIPTION	REMARKS
1	TM-H001	1	QUILL HOUSING	
2	TM-H002	1	GEAR HOUSING	
3	TM-H003	1	GEAR HOUSING COVER	
4	TM-H004	1	BELT HOUSING	
5	TM-H005	1	SPINDLE PULLEY	
6	TM-H006	1	MOTOR PULLEY	
7	TM-H007	1	TIMING BELT PULLEY	
8	TM-H008	2	TIMING BELT PULLEY FLANGE	
9	TM-H012	1	BACK GEAR SHIFTER FORK	
10	TM-H013	1	SPINDLE PULLEY BEARING SLEEVE	
11	TM-H019	1	MOTOR PULLEY WASHER	
12	TM-H030	1	DRAWBAR KNOB (NT 30 1/2" x W12)	
13	TM-H031	1	DRAWBAR KNOB	
14	TM-H032	1	DRAWBAR KNOB	
15	TM-H035	1	QUILL SKIRT	
16	TM-H036	1	QUILL STOP KNOB	
17	TM-H037	1	QUILL STOP MICRO SCREW (IN)	
18	TM-H038	1	MICROMETER NUT	
19	TM-H070	3	VERTICAL TEE BOLT	
20	TM-H071	3	VERTICAL TEE BOLT WASHER	
21	TM-H072	1	SPINDLE GEAR HUB	
22	TM-H074	1	SPINDLE BULL GEAR	
23	TM-H075	1	SPINDLE PULLEY HUB	
24	TM-H076	1	PULLEY COLLAR	
25	TM-H080	1	UPPER BEARING SPACER	
26	TM-H081	1	BEARING SPACER	
27	TM-H082	1	BEARING SLEEVE LOCK NUT	
28	TM-H083	1	UPPER BEARING LOCK NUT	
29	TM-H084	1	CAM RING	
30	TM-H085	1	SPINDLE CLUTCH LEVER	
31	TM-H087	1	BRAKE BLOCK	
32	TM-H095	1	COUNTER SHAFT	
33	TM-H096	1	COUNTER SHAFT GEAR	
34	TM-H126	1	FEED DRIVE WORM GEAR	

FILE NAME: TM-01

2150-7721-100

PARTS NO.		PC	DESCRIPTION	REMARKS
35	TM-H131	2	MOTOR LOCK NUT	
36	TM-H132	2	MOTOR LOCK NUT HANDLE	
37	TM-H133	2	MOTOR MOUNTING STUDS	
38	TM-H134	2	MOTOR MOUNTING STUDS WASHER	
39	TM-H149	1	DRAWBAR WASHER (R8)	
40	TM-H150	2	SOCKET SET SCREW	
41	TM-H157	1	QUILL MICRO STOP NUT (IN)	
42	TM-H165	1	SPINDLE (NT 30)	
43	TM-H166	1	SPINDLE (R8)	
44	TM-H167	1	QUILL (R8/NT 30)	
45	TM-H169	1	SPINDLE DIRT SHIELD (R8/NT 30)	
46	TM-H170	1	BEARING SPACER (R8/NT 30)	
47	TM-H171	1	BEARING SPACER (R8/NT 30)	
48	TM-H172	1	NOSE PIECE (R8)	
49	TM-H173	1	NOSE PIECE (NT 30)	
50	TM-H176	1	SLEEVE	
51	TM-H256	4	SPRING	
52	TM-H276	2	RONUD HD MACHINE SCREW	M5 x 12
53	TM-H278	1	SCREW	3/8" x 5/8"
54	TM-H284	8	BLACK PLASTIC BALL	
55	TM-H421	1	QUILL STOP MICRO SCREW (mm)	
56	TM-H422	1	MICRO METER NUT (mm)	
57	TM-H423	1	QUILL MICRO STOP NUT (mm)	
58	TM-H431	1	DRAWBAR KNOB (NT 30 1/2" x W13)	
59	TM-H470	1	BEARING SPCER (NT 40)	
60	TM-H471	1	BEARING SPCER (NT 40)	
61				
62	TM-C127	4	WASHER	
63				
64	18VH-H047	1	SPINDLE (NT 40)	
65	18VH-H048	1	NOSE PIECE (NT 40)	
66	18VH-H049	1	SPINDLE DIRT SHIELD (NT 40)	
67	18VH-H052	1	DRAWBAR WASHER (NT 40)	
68	18VH-H055	1	BEARING SPCER (NT 40)	

FILE NAME: TM-02

2150-7721-100

PARTS NO.		PC	DESCRIPTION	REMARKS
1	TM-H004	1	BELT HOUSING	
2	TM-H013	1	SPINDLE PULLEY BEARING SLEEVE	
3	TM-H084	1	CAM RING	
4	TM-H086	2	SPINDLE CLUTCH CAM RING PIN	
5	TM-H087	1	BRAKE BLOCK	
6	TM-H088	2	BRAKE RING SCREW	
7	TM-H089	1	BRAKE LOCK STUD	
8	TM-H091	1	BRAKE LOCK WASHER	
9	TM-H092	1	BRAKE LOCK HANDLE	
10	TM-H093	1	BRAKE LOCK PIN	
11	TM-H284	1	BLACK PLASTIC BALL	
12	TM-H297	2	SPRING	
13	TM-H472	1	BRAKE RING SCREW	
14				
15				
16				
17				
18				
19				
20				
21				
22				
23				
24				
25				
26				
27				
28				
29				
30				
31				
32				
33				
34				

FILE NAME: TM-05

2150-7721-100

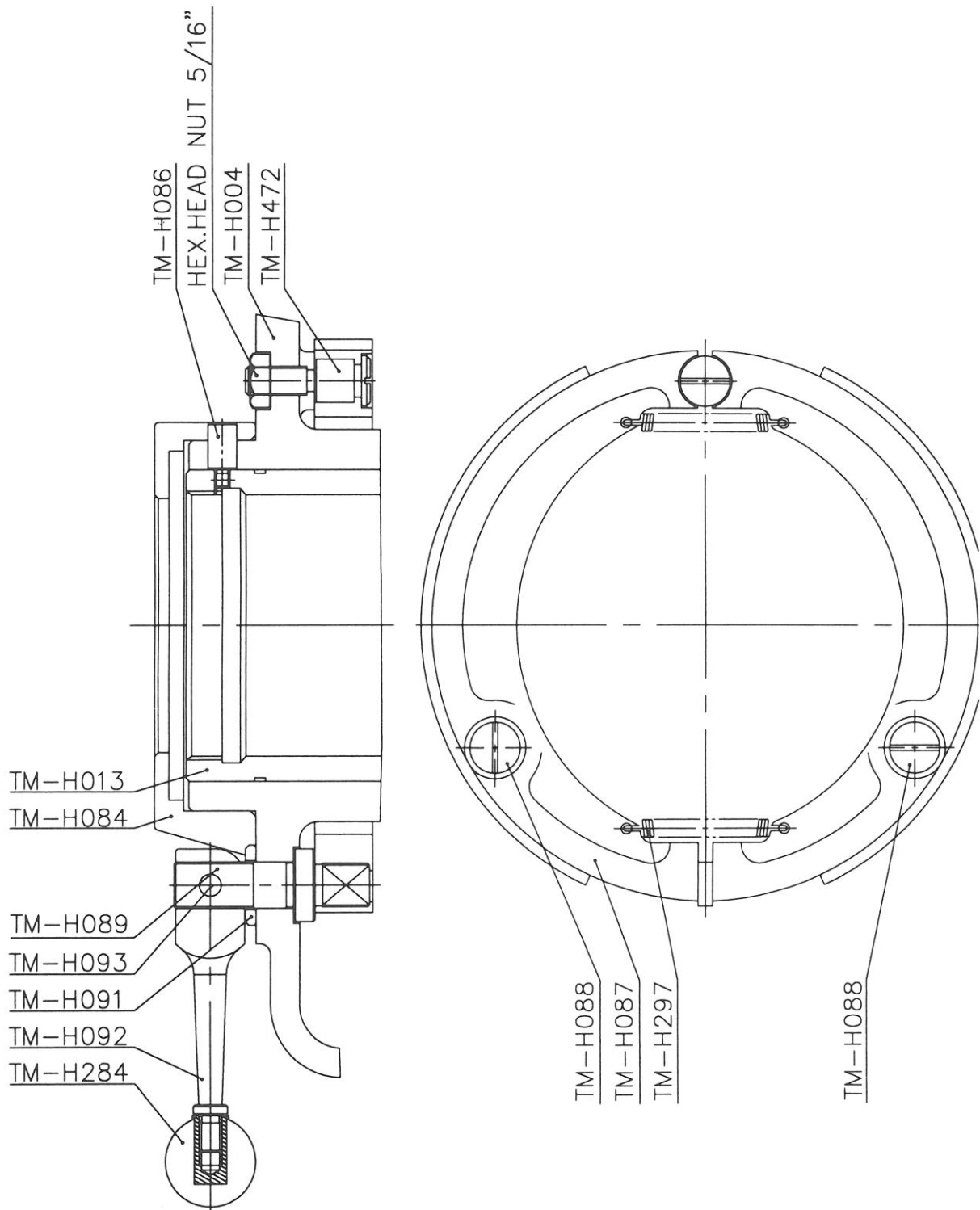

FILE NAME: TM-06

2150-7721-100

PARTS NO.		PC	DESCRIPTION	REMARKS
1	TM-H001	1	BELT HOUSING	
2	TM-H009	1	SPINDLE PULLEY BEARING SLEEVE	
3	TM-H010	1	CAM RING	
4	TM-H014	3	SPINDLE CLUTCH CAM RING PIN	
5	TM-H016	1	BRAKE BLOCK	
6	TM-H017	1	BRAKE RING SCREW	
7	TM-H018	1	BRAKE LOCK STUD	
8	TM-H021	1	BRAKE LOCK WASHER	
9	TM-H029	1	BRAKE LOCK HANDLE	
10	TM-H032	1	BRAKE LOCK PIN	
11	TM-H033	1	BLACK PLASTIC BALL	
12	TM-H047	1	SPRING	
13	TM-H048	1	BRAKE RING SCREW	
14	TM-H051	1	OVERLOAD CLUTCH LEVER SPRING PLUNGER	
15	TM-H052	1	OVERLOAD CLUTCH WASHER	
16	TM-H053	1	CLUTCH RING	
17	TM-H054	1	OVERLOAD CLUTCH SLEEVE	
18	TM-H055	1	PINION SHAFT HUB	
19	TM-H056	1	PINION SHAFT HUB HANDLE	
20	TM-H058	1	OVERLOAD CLUTCH	
21	TM-H059	1	OVERLOAD CLUTCH RING	
22	TM-H060	1	OVERLOAD CLUTCH WORM GEAR	
23	TM-H061	1	PINION SHAFT WORM GEAR SPACER	
24	TM-H062	1	QUILL PINION SHAFT BUSHING	
25	TM-H063	1	QUILL PINION SHAFT	
26	TM-H064	1	QUILL PINION OVERLOAD CLUTCH LOCK NUT	
27	TM-H090	1	LOCK SPRING STUD	
28	TM-H092	1	BRAKE LOCK HANDLE	
29	TM-H094	2	LOWER CLAMPING BOLT SPACER	
30	TM-H097	3	GEAR SHAFT PLUNGER	
31	TM-H102	1	FEED DRIVE CLUSTER GEAR	
32	TM-H103	1	FEED DRIVE GEAR	
33	TM-H104	1	CLUSTER GEAR INPUT SHAFT	
34	TM-H108	1	BEVEL GEAR BEARING	

FILE NAME: TM-H03-P1

PARTS NO.		P C	DESCRIPTION	REMARKS
35	TM-H109	1	BEVEL GEAR THRUST SPACER	
36	TM-H110	1	FEED REVERSE BEVEL GEAR	
37	TM-H111	1	FEED WORM SHAFT THRUST WASHER	
38	TM-H112	1	FEED REVERSE CLUTCH	
39	TM-H114	1	FEED WORM SHAFT BUSHING	
40	TM-H115	1	FEED REVERSE BEVEL GEAR	
41	TM-H116	1	REVERSE CLUTCH ROD	
42	TM-H117	1	REVERSE KNOB	
43	TM-H118	1	HANWHEEL CLUTCH	
44	TM-H125	2	WORM GEAR SPACER	
45	TM-H126	1	FEED DRIVE WORM GEAR	
46	TM-H128	1	FEED ENGAGE PIN	
47	TM-H130	1	SHIFT SLEEVE	
48	TM-H136	1	WORM CRADLE BUSHING	
49	TM-H146	1	FEED REVERSE BEVEL PINION	
50	TM-H147	1	CLUSTER GEAR SHAFT UPPER BEARING	
51	TM-H148	1	PINION SHAFT HUB SCREW	
52	TM-H154	2	CLUTCH RING SCREW	
53	TM-H155	4	1/2" T-BOLT	
54	TM-H156	1	BOLT	
55	TM-H167	1	QUILL	
56	TM-H190	2	SPECIAL HEX NUT	
57	TM-H191	2	SPECIAL HEX NUT	
58	TM-H192	1	WASHER	
59	TM-H251	1	SOCKET SET SCREW	
60	TM-H260	1	ROLL PIN	
61	TM-H262	3	SPRING	
62	TM-H284	8	BLACK PLASTIC BALL	
63	TM-H305	2	SLEEVE	
64	TM-H307	1	WORM	
65	TM-H312	1	WASHER	
66	TM-H321	1	SAFETY CLUTCH SPRING	
67	TM-H324	1	FEED REVERSE BEVEL GEAR	
68	TM-H327	1	FEED REVERSE BEVEL PINION	

FILE NAME: TM-H03-P2

PARTS NO.		PC	DESCRIPTION	REMARKS
69	TM-H	1	SCREW	
70	TM-H	2	BLACK PLASTIC BALL HANDLE	
71	TM-H	1	BUSHING	
72				
73				
74				
75	TM-C	4	TABLE LOCK BOLT HANDLE	
76				
77				
78				
79				
90				
91				
92				
93				
94				
95				
96				
97				
98				
99				

FILE NAME: TM-H03-P3

FILE NAME: TM/VS-04
2150-7721-100

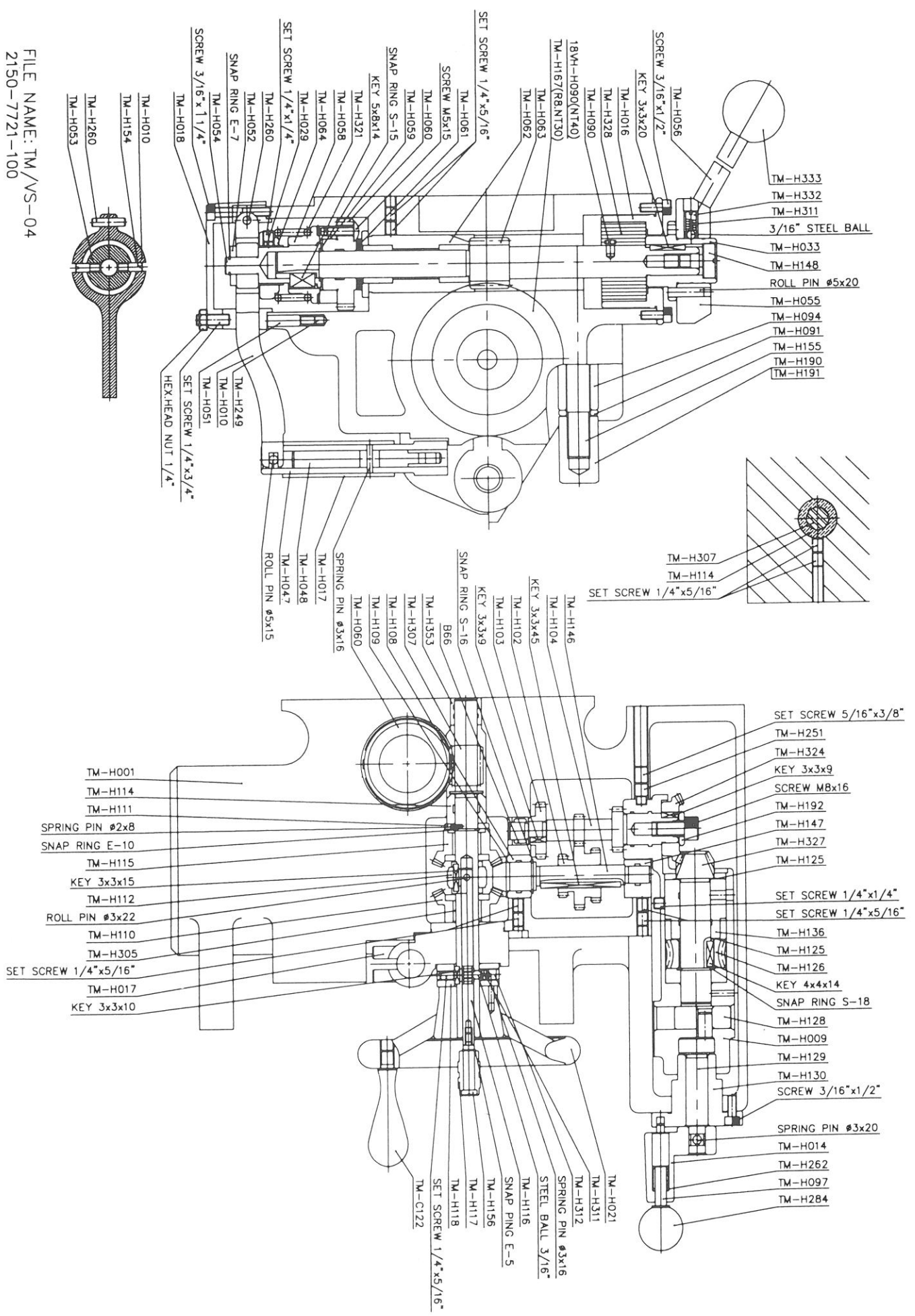

PARTS NO.		PC	DESCRIPTION	REMARKS
1	TM-H001	1	QUILL HOUSING	
2	TM-H010	1	OVERLOAD CLUTCH TRIP LEVER	
3	TM-H011	1	FEED GEAR SHIFTER FORK	
4	TM-H014	3	SHIFT CRANK	
5	TM-H015	1	CLUSTER GEAR COVER	
6	TM-H016	1	SPRING COVER	
7	TM-H0171	1	FEED TRIP BRACKET	
8	TM-H018	1	CLUTCH ARM COVER	
9	TM-H033	1	PINION SHAFT HUB SLEEVE	
10	TM-H036	1	QUILL STOP KNOB	
11	TM-H037	1	QUILL STOP MICRO SCREW	
12	TM-H038	1	MICROMETER SCALE	
13	TM-H039	1	REVERSE TRIP BALL LEVER	
14	TM-H040	1	FEED REVERSE TRIP PLUNGER	
15	TM-H041	1	REVERSE TRIP BALL LEVER SCREW	
16	TM-H042	1	FEED TRIP LEVER	
17	TM-H043	1	FEED TRIP PLUNGER	
18	TM-H044	1	TRIP PLUNGER BUSHING	
19	TM-H045	1	TRIP PLUNGER	
20	TM-H046	1	FEED TRIP PLUNGER BUSHING	
21	TM-H047	1	CAM ROD SLEEVE ASSEMBLY	
22	TM-H048	1	CAM ROD	
23	TM-H049	1	TRIP HAND	
24	TM-H055	1	PINION SHAFT HUB	
25	TM-H056	1	PINION SHAFT HUB HANDLE	
26	TM-H067	1	QUILL LOCK BOLT	
27	TM-H091	12	BRAKE LOCK WASHER	
28	TM-H097	3	GEAR SHAFT PLUNGER	
29	TM-H098	1	CLUSTER GEAR SHIFT CRANK	
30	TM-H102	1	FEED DRIVE CLUSTER GEAR	
31	TM-H145	1	FEED SHIFT ROD	
32	TM-H146	1	FEED REVERSE BEVEL PINION	
33	TM-H147	1	CLUSTER GEAR SHAFT UPPER BEARING	
34	TM-H151	1	TRIP LEVER PIN	

FILE NAME: TM-H04-P1

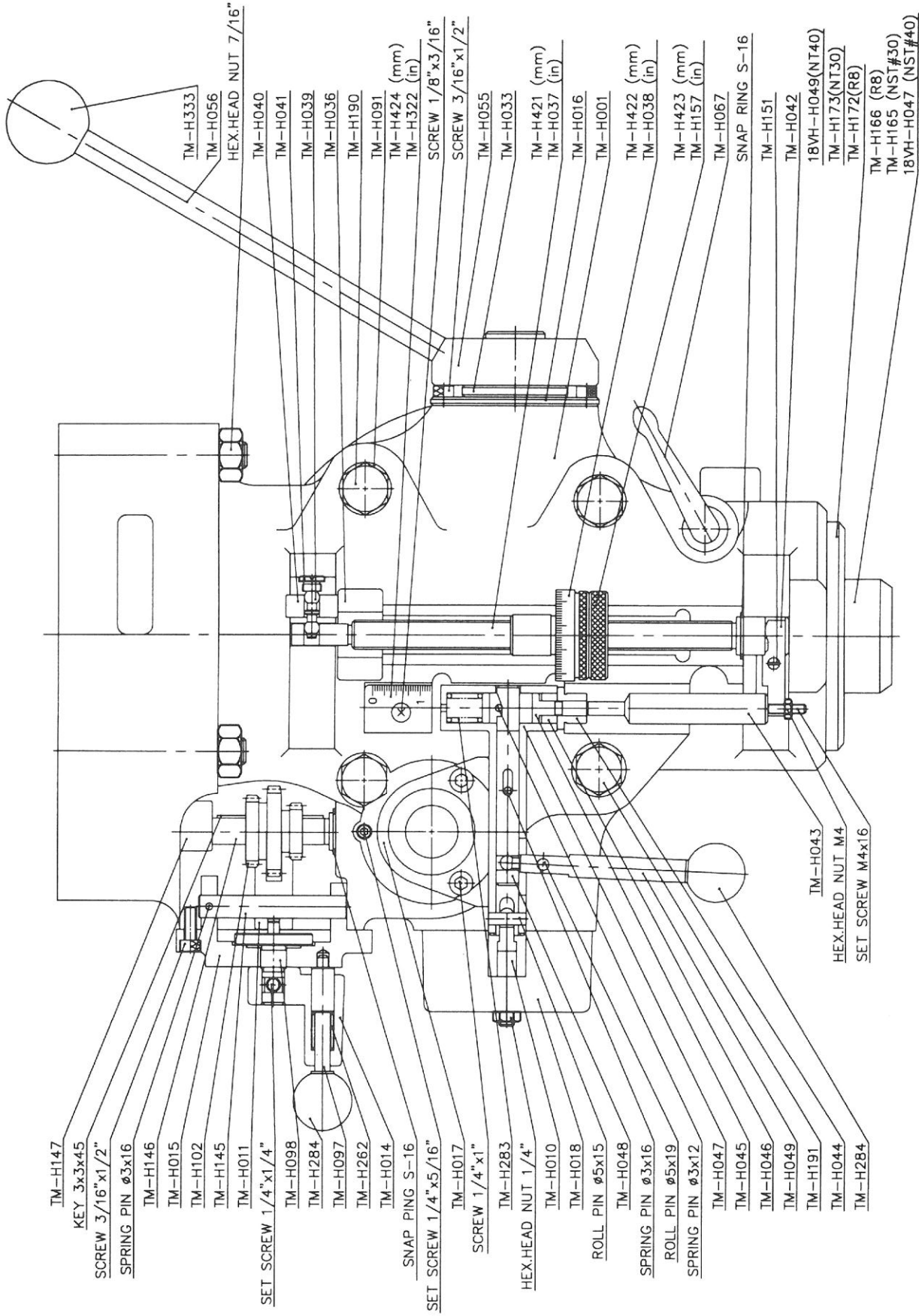

- TM-H147
- KEY 3x3x4.5
- SCREW 3/16"x1/2"
- SPRING PIN ϕ 3x16
- TM-H146
- TM-H015
- TM-H102
- TM-H145
- TM-H011
- SET SCREW 1/4"x1/4"
- TM-H098
- TM-H284
- TM-H097
- TM-H262
- TM-H014
- SNAP RING S-16
- SET SCREW 1/4"x5/16"
- TM-H017
- SCREW 1/4"x1"
- TM-H283
- HEX.HEAD NUT 1/4"
- TM-H010
- TM-H018
- ROLL PIN ϕ 5x15
- TM-H048
- SPRING PIN ϕ 3x16
- ROLL PIN ϕ 5x19
- SPRING PIN ϕ 3x12
- TM-H047
- TM-H045
- TM-H046
- TM-H049
- TM-H191
- TM-H044
- TM-H284
- TM-H091
- TM-H424 (mm)
- TM-H322 (in)
- SCREW 1/8"x3/16"
- SCREW 3/16"x1/2"
- TM-H055
- TM-H033
- TM-H421 (mm)
- TM-H037 (in)
- TM-H016
- TM-H001
- TM-H422 (mm)
- TM-H038 (in)
- TM-H423 (mm)
- TM-H157 (in)
- TM-H067
- SNAP RING S-16
- TM-H151
- TM-H042
- 18VH-H049(NST40)
- TM-H173(NST30)
- TM-H172(R8)
- TM-H166 (R8)
- TM-H165 (NST#30)
- 18VH-H047 (NST#40)
- TM-H043
- HEX.HEAD NUT M4
- SET SCREW M4x16

FILE NAME: TM/VS-07
2150-7721-100

PARTS NO.		PC	DESCRIPTION	REMARKS
1	TM-H002	1	GEAR HOUSING	
2	TM-H003	1	GEAR HOUSING COVER	
3	TM-H004	1	BELT HOUSING	
4	TM-H012	1	BACK GEAR SHIFTER FORK	
5	TM-H014	3	SHIFT CRANK	
6	TM-H95	1	COUNTER SHAFT	
7	TM-H96	1	COUNTER SHAFT GEAR	
8	TM-H97	3	GEAR SHAFT PLUNGER	
9	TM-H152	1	BACK GEAR SHAFT BUSHING	
10	TM-H153	1	BACK GEAR SHAFT CRANK	
11	TM-H284	8	BLACK PLASTIC BALL	
12	TM-H334	1	SUB GEAR SHAFT	
13				
14				
15				
16				
17				
18				
19				
20				
21				
22				
23				
24				
25				
26				
27				
28				
29				
30				
31				
32				
33				
34				

FILE NAME: TM-H05

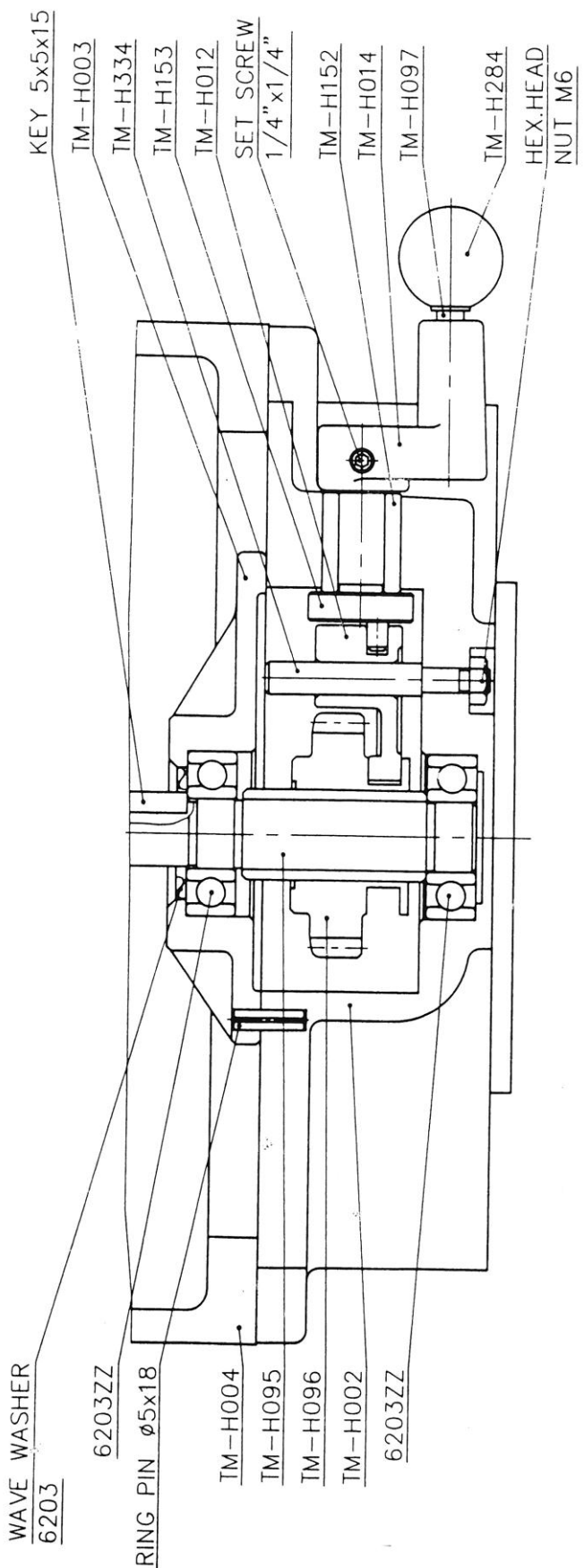

50R-H-5
 TM-H-5
 81.08.15

PARTS NO.		PC	DESCRIPTION	REMARKS
1	TM-H065	1	QUILL LOCK SLEEVE	
2	TM-H066	1	QUILL LOCK SLEEVE	
3	TM-H067	1	QUILL LOCK BOLT	
4	TM-H140	1	WORM GEAR	
5	TM-H141	1	WORM SHAFT	
6	TM-H143	1	SOCKET SET SCREW	
7	TM-H144	1	GEAR	
8				
9				
10				
11				
12				
13				
14				
15				
16				
17				
18				
19				
20				
21				
22				
23				
24				
25				
26				
27				
28				
29				
30				
31				
32				
33				
34				

FILE NAME: TM-H06

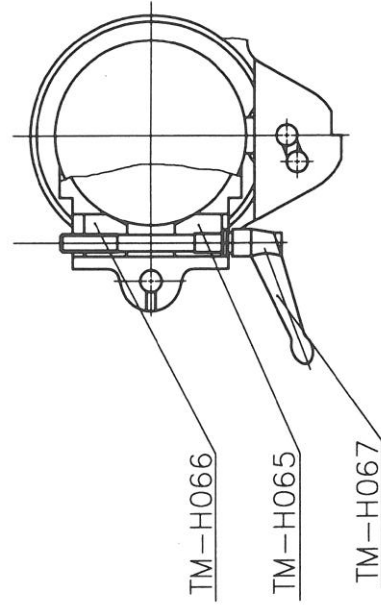
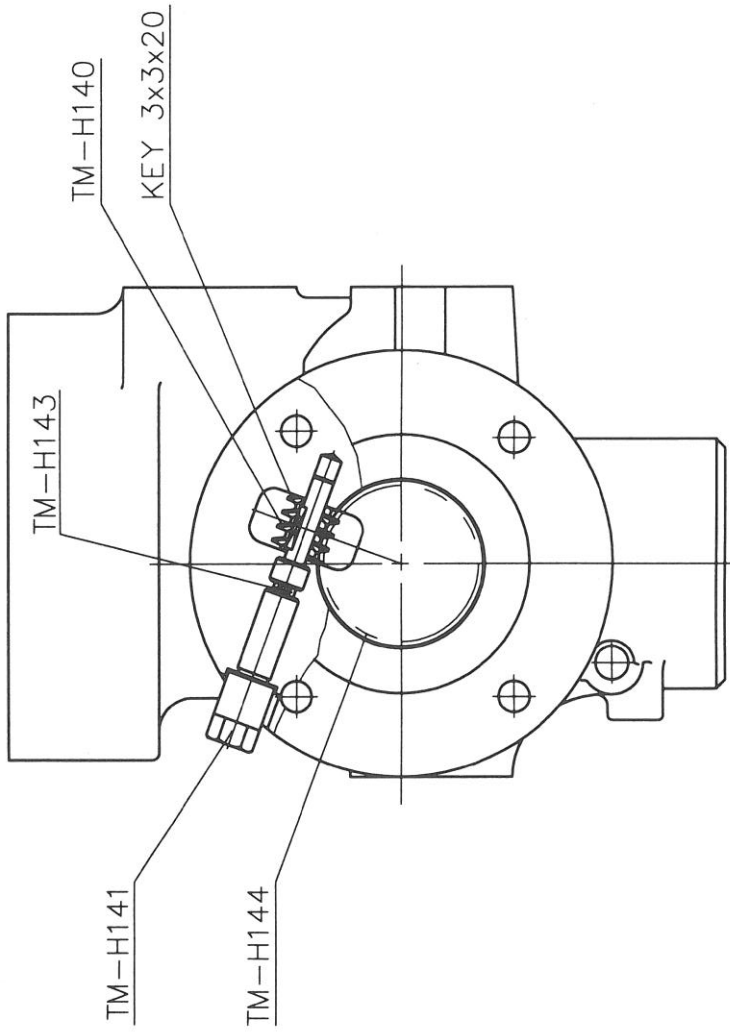

FILE NAME: TM/V/S-09

2150-7721-100

PARTS NO.		PC	DESCRIPTION	REMARKS
1	TM-C069	4	DIAL LOCK NUT	
2	TM-C074	2	DIAL HOLDER	
3	TM-C078	3	DIAL WITH 200 DRADUATIONS	
4	TM-C179	1	DIAL HOLDER	
5	TM-C080	3	HAND WHEEL	
6	TM-C108	2	LOCK SCREW	
7	TM-C109	2	SCREW ADJUSTING NUT	
8	TM-C110	1	FEED NUT BRACKET	
9	TM-C112	1	LONGITUDINAL FEED NUT	
10	B311-A	1	LONGITUDINAL FEED SCREW	
11	TM-C117	1	BEARING SPACER	
12	TM-C118	1	RIGHT BEARING BRACKET	
13				
14				
15				
16				
17				
18				
19				
20				
21				
22				
23				
24				
25				
26				
27				
28				
29				
30				
31				
32				
33				
34				

FILE NAME: TM-C01

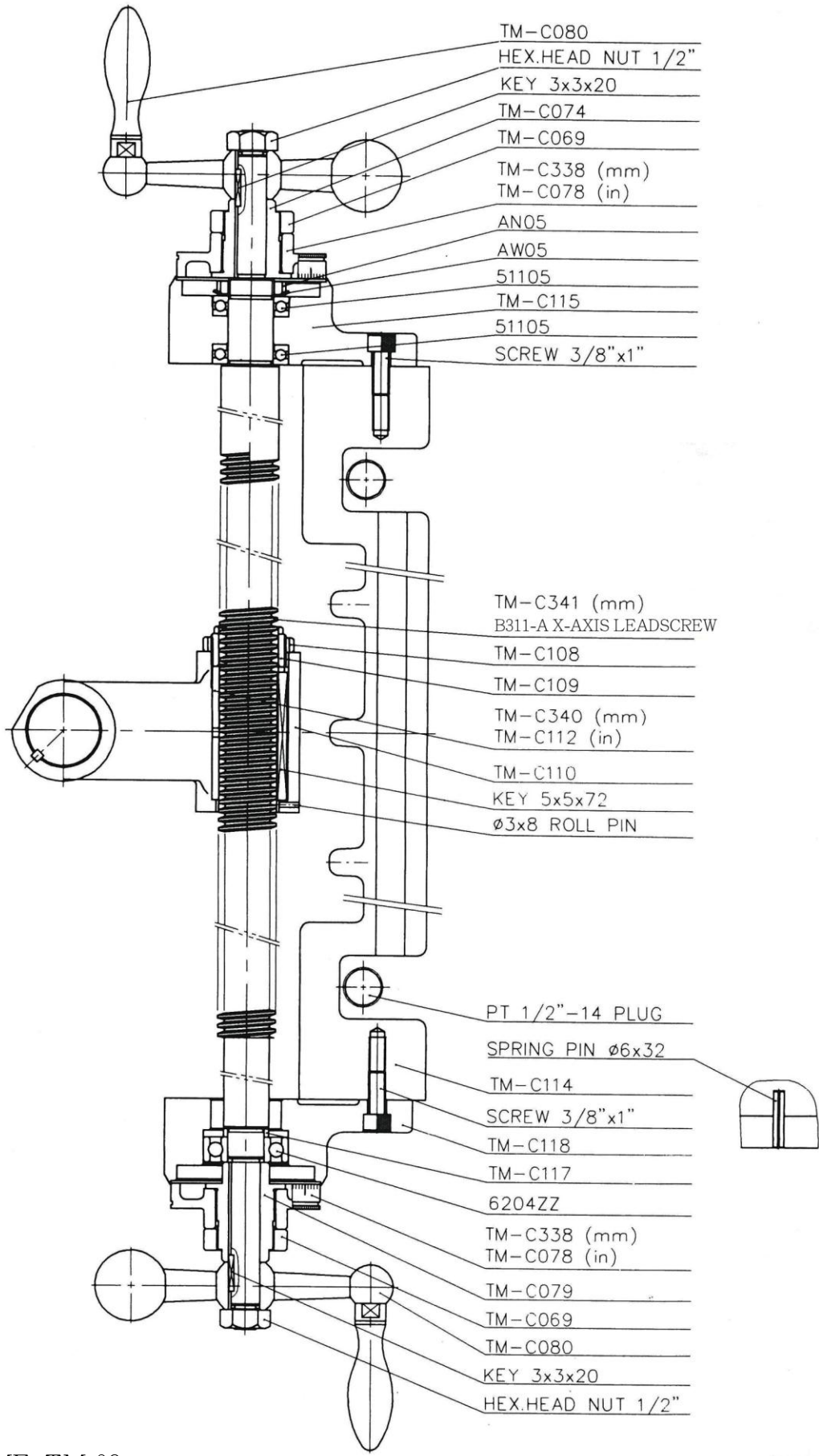

FILE NAME: TM-06

PARTS NO.		PC	DESCRIPTION	REMARKS
1	TM-C050	1	KNEE	
2	TM-C105	1	SADDLE	
3	TM-C114	1	TABLE	
4	TM-C119	1	SADDLE-TABLE GIB	
5	TM-C120	5	TABLE LOCK PLUNGER	
6	TM-C121	2	TABLE LOCK BOLT	
7	TM-C122	4	TABLE LOCK BOLT HANDLE	
8	TM-C123	1	TABLE STOP BRACKET	
9	TM-C125	2	TABLE STOP PIECE	
10	TM-C126	2	STOP PIECE T-BOLT	
11	TM-C129	2	LEFT HAND KNEE-SADDLE WIPER HOLDER	
12	TM-C130	2	RIGHT HAND KNEE-SADDLE WIPER	
13	TM-C131	1	SADDLE-KNEE GIB	
14	TM-C132	1	SADDLE LOCK PLUNGER	
15	TM-C133	1	SADDLE LOCK BOLT	
16	TM-C134	2	UPPER KNEE-SADDLE WIPER	
17	30A-070B		GIB ADJUSTING SCREW	
18				
19				
20				
21				
22				
23				
24				
25				
26				
27				
28				
29				
30				
31				
32				
33				
34				

FILE NAME: TM-C02

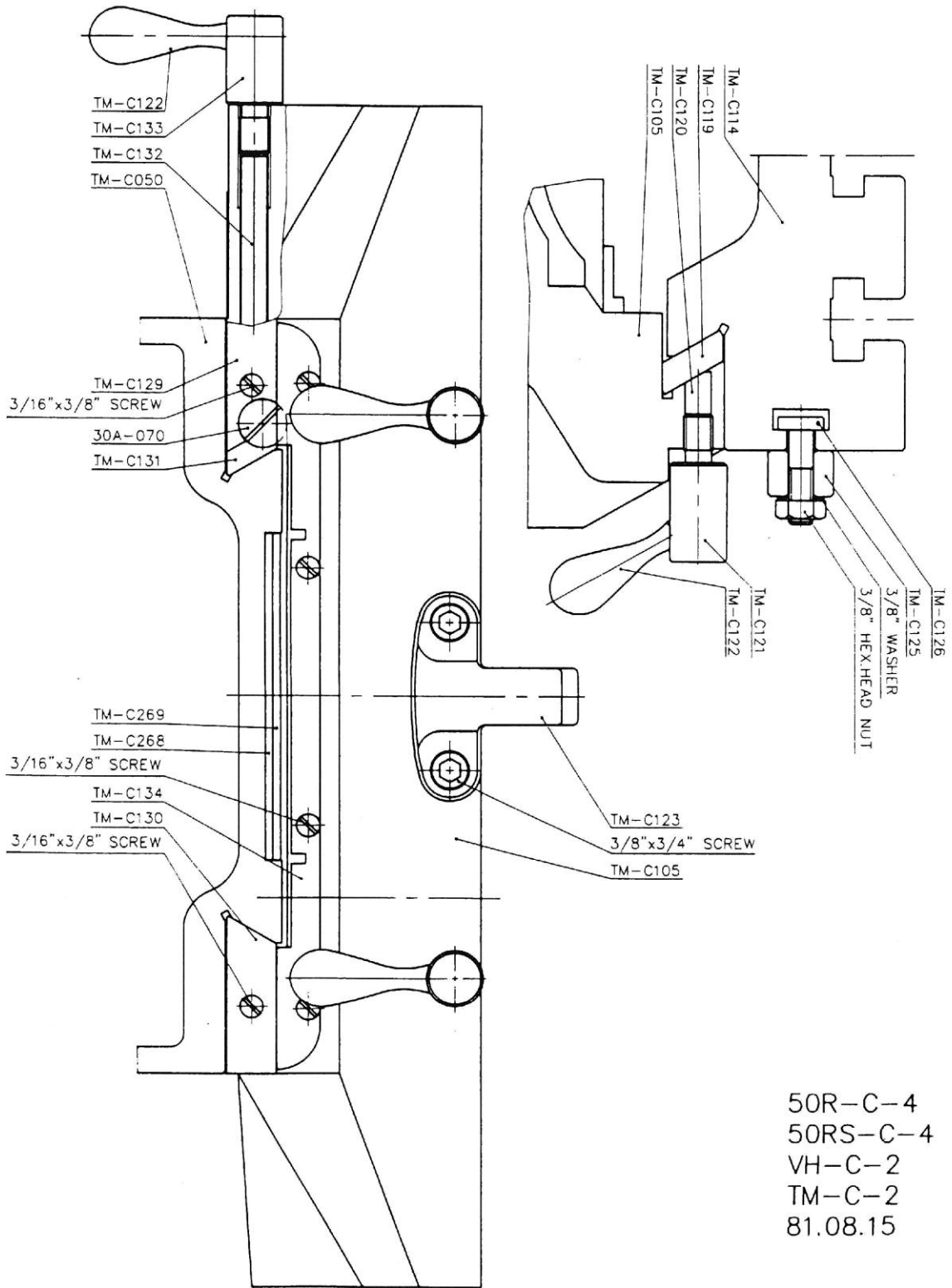

PARTS NO.		PC	DESCRIPTION	REMARKS
1	TM-C002	1	ELEVATING SCREW HOUSING	
2	TM-C003	1	ELEVATING SCREW HOUSING	
3	TM-C050	1	KNEE	
4	TM-C051	1	SOCKET HD CAP SCREW	
5	TM-C057	1	WASHER	
6	TM-C059	1	BEVEL GEAR	
7	TM-C069	4	DIAL LOCK NUT	
8	TM-C074	2	DIAL HOLDER	
9	TM-C075	1	CROSS FEED SCREW	
10	TM-C077	1	CROSS FEED BEARING BRACKET	
11	TM-C078	3	DIAL WITH 200 GRADUATIONS	
12	TM-C080	3	HANDWHEEL	
13	TM-C105	1	SADDLE	
14	TM-C108	2	LOCK SCREW	
15	TM-C109	2	SCREW ADJUSTING NUT	
16	TM-C110	1	FEED NUT BRACKET	
17	TM-C114	1	TABLE	
18	TM-C119	1	SADDLE-TABLE GIB	
19	TM-C134	2	UPPER KNEE-SADDLE WIPER	
20	TM-C268	1	CHIP GUARD COVER PLATE	
21	TM-C269	1	CHIP GUARD COVER PLATE	
22	TM-C271	1	COLUMN	
23	TM-C276	1	CHIP COVER PLATE	
24	TM-C277	2	CHIP COVER PLATES	
25	TM-C106	2	CROSS FEED NUT	
26	18VS-T160	1	CHIP GUARD RUBBER	
27				
28				
29				
30				
31				
32				
33				
34				

FILE NAME: TM-C03

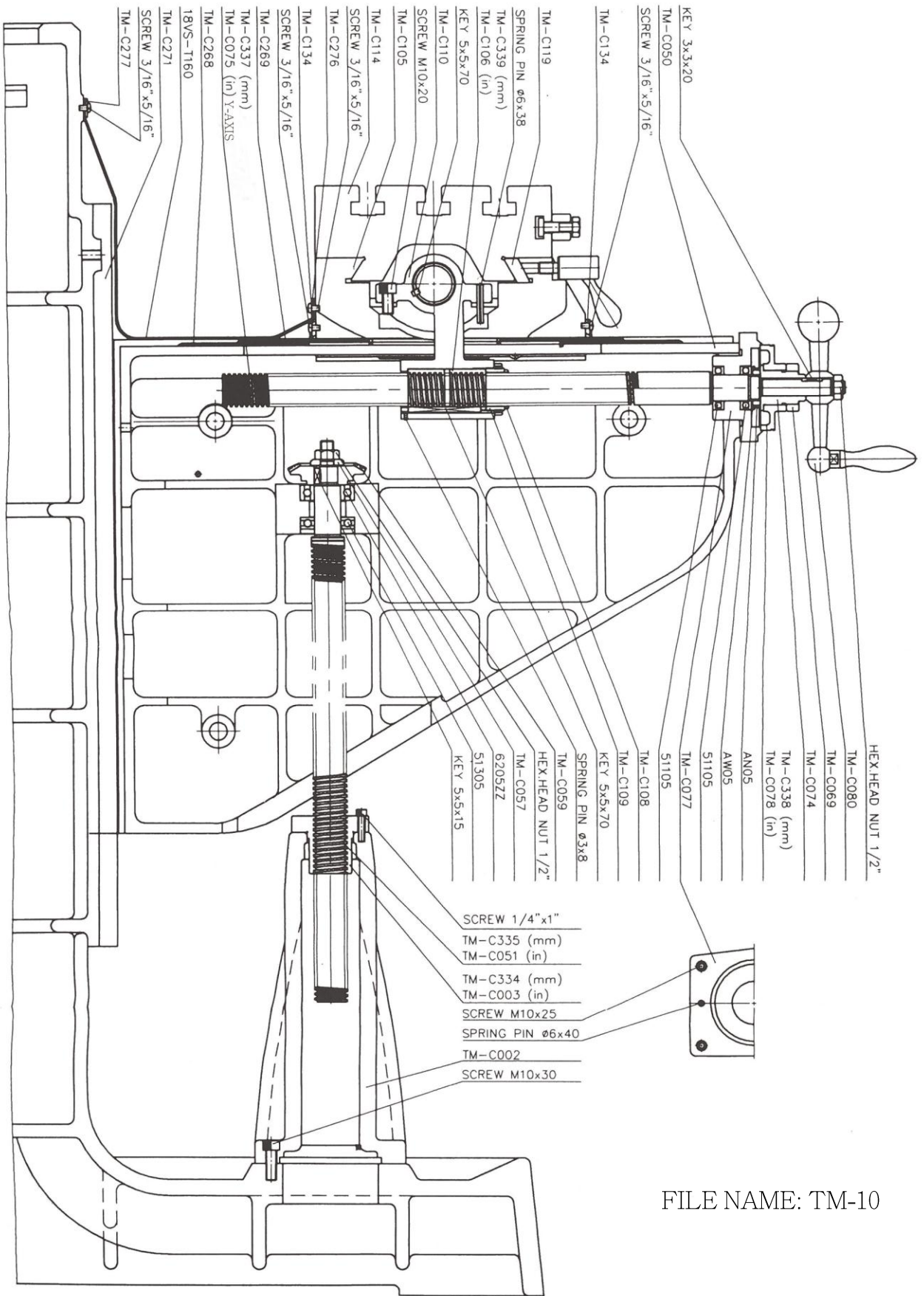

FILE NAME: TM-10

PARTS NO.		PC	DESCRIPTION	REMARKS
1	TM-C028	1	HANDLE	
2	TM-C051	1	SOCKET HD CAP SCREW	
3	TM-C057	1	WASHER	
4	TM-C059	1	BEVEL GEAR	
5	TM-C060	1	BEVEL PINION	
6	TM-C063	1	GEAR SHAFT FOR KNEE	
7	TM-C064	1	BEARING CUP	
8	TM-C065	1	BEARING RETAINER RING	
9	TM-C068	1	DIAL HOLDER	
10	TM-C069	4	DIAL LOCK NUT	
11	TM-C070	1	GEAR SHAFT CLUTCH INSERT	
12	TM-C071	1	ELEVATING CRANK	
13	TM-C336	1	DIAL WITH 100 GRADUATIONS	
14				
15				
16				
17				
18				
19				
20				
21				
22				
23				
24				
25				
26				
27				
28				
29				
30				
31				
32				
33				
34				

FILE NAME: TM-C04

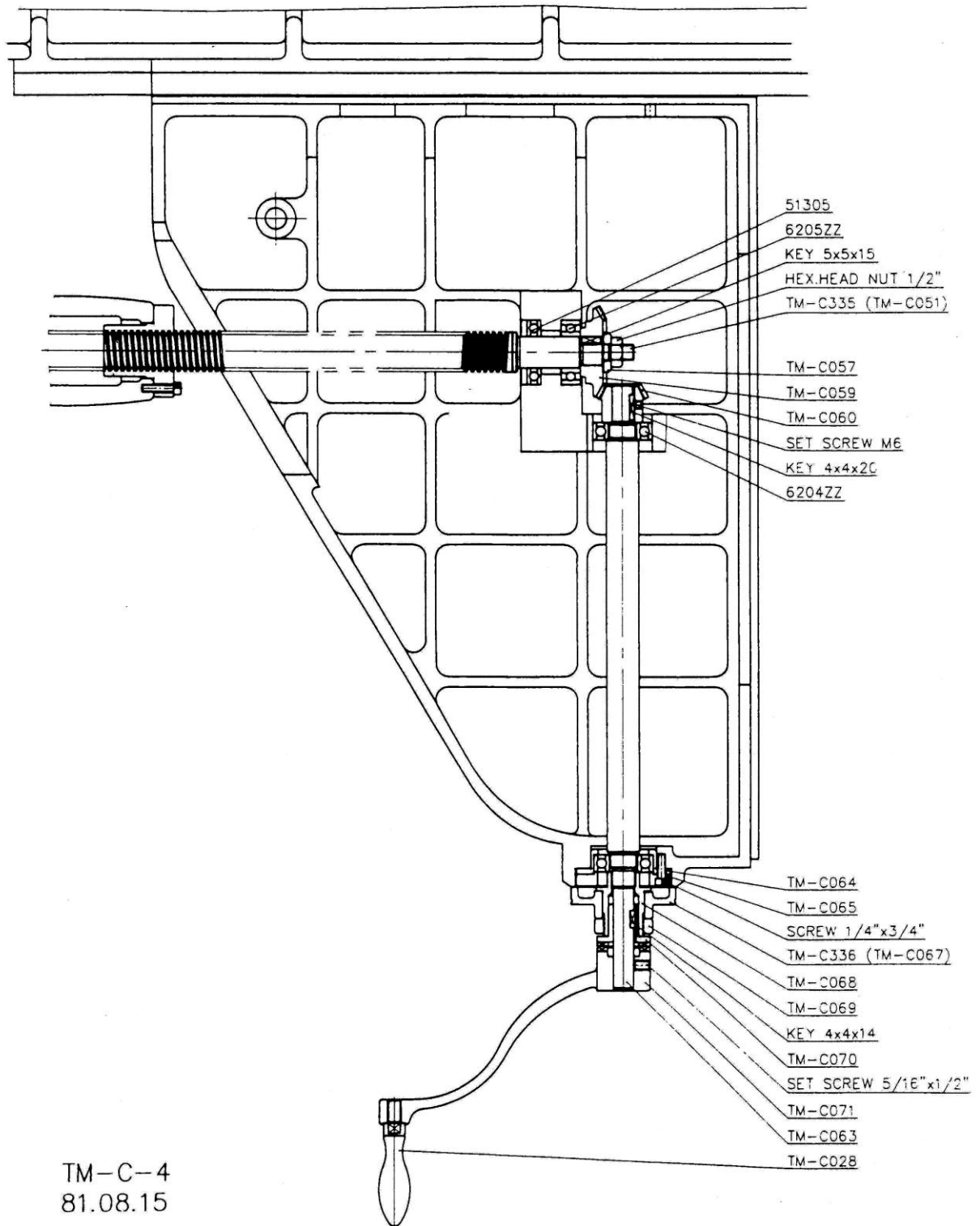

TM-C-4
 81.08.15

PARTS NO.		PC	DESCRIPTION	REMARKS
1	TM-C222	1	UPPER WORM SPACER	
2	TM-C224	1	RAM	
3	TM-C225	1	RAM ADAPTER	
4	TM-C226	1	VERTICAL ADJUSTING WORM	
5	TM-C227	1	VERTICAL ADJUSTING WORM SHAFT	
6	TM-C232	1	WORM THRUST WASHER	
7	TM-C254	1	TURRET	
8				
9				
10				
11	TM-H144	1	GEAR	
12				
13				
14				
15				
16				
17				
18				
19				
20				
21				
22				
23				
24				
25				
26				
27				
28				
29				
30				
31				
32				
33				
34				

FILE NAME: TM-C05

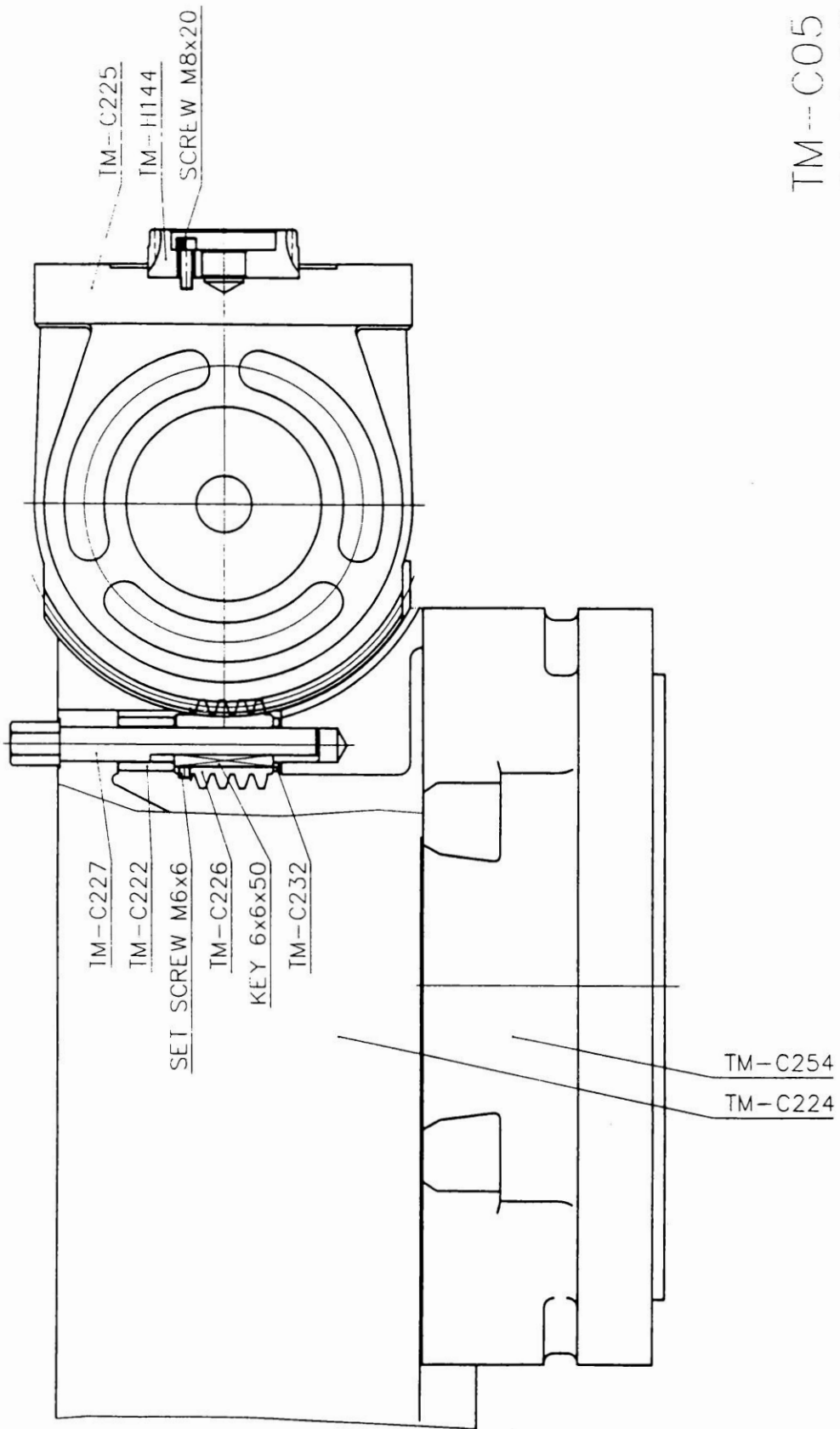

TM--C05
81.10.23

PARTS NO.		PC	DESCRIPTION	REMARKS
1	TM-C219	1	HEAD ROTATING STOP PIN	
2	TM-C220	1	STOP PIN BASE	
3	TM-C224	1	RAM	
4	TM-C225	1	RAM ADAPTER	
5	TM-C228	1	ADAPTER PIVOT STUD	
6	TM-C230	2	RAM LOCK BOLT	
7	TM-C231	1	RAM PINION	
8	TM-C233	2	RAM LOCK BOLT HANDLE	
9	TM-C234	2	ADJUSTING BOLT-GIB	
10	TM-C236	1	SCALE	
11	TM-C237	1	RAM PINION HANDLE	
12	TM-C238	1	RAM PINION SCREW	
13	TM-C254	1	TURRET	
14	TM-C270	4	TURRET CLAMP BOLTS	
15	TM-C271	1	COLUMN	
16	TM-C473	6	T-BOLT	
17	TM-C217	1	SCALE	
18	TM-C272	1	SCALE	
19				
20	TM-H091	10	BRAKE LOCK WASHER	
21	TM-H333	1	BLACK PLASTIC BALL HANDLE	
22				
23				
24				
25	2G-H033	2	GRIP	
26				
27				
28				
29				
30				
31				
32				
33				
34				

FILE NAME: TM-03

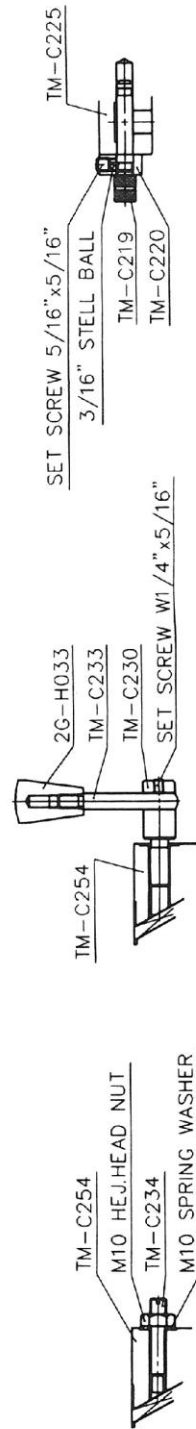
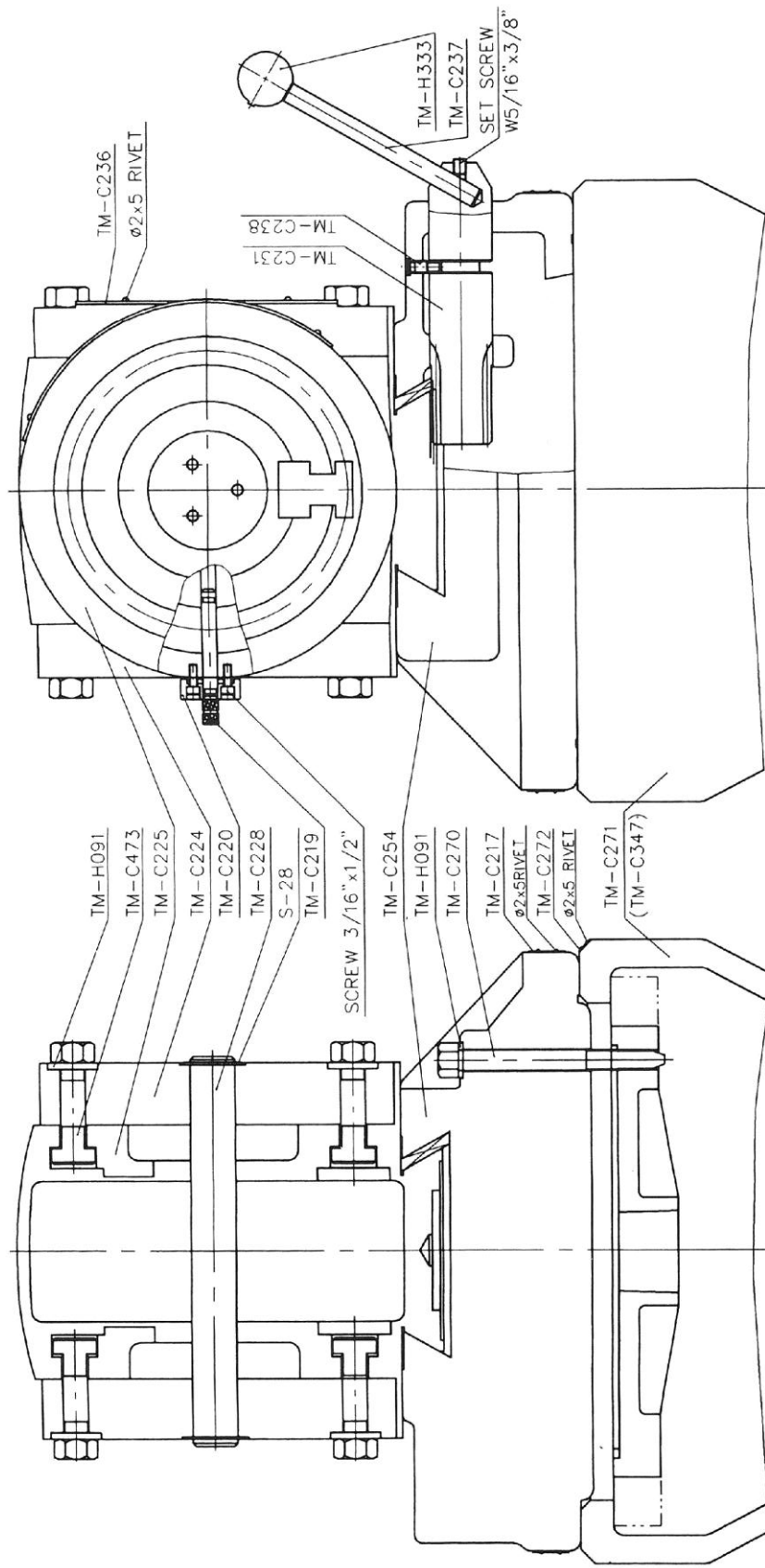

PARTS NO.		PC	DESCRIPTION	REMARKS
1	VH-H503	1	GEAR HOUSING PLATE	
2	VH-H504	1	BELT HOUSING (BOTTOM)	
3	VH-H505	1	BELT HOUSING (UP)	
4	VH-H506	3	STUDS	
5	VH-H507	1	GEAR HOUSING	
6	VH-H515	1	TOP BEARING CAP	
7	VH-H520	1	KEY	
8	VH-H521	1	ADJ DRIVEN VARI-DISC ASSEMBLY	
9	VH-H523	1	SLIDING HOUSING	
10	VH-H525	1	STATIONARY DRIVEN VARI-DISC	
11	VH-H526	1	STATIONARY MOTOR VARI-DISC	
12	VH-H528	2	MOTOR	
13	VH-H531	1	SLIDING KEY	
14	VH-H533	1	ADJ MOTOR VARI-DISC	
15	VH-H534	1	SPRING	
16	VH-H535	1	SPRING WASHER	
17	VH-H539	1	MOTOR PULLEY COVER	
18	VH-H541	1	DRAWBAR (R8)	
19	VH-H544	1	BRAKE BRG. CAP	
20	VH-H545	1	BRAKE SHOE	
21	VH-H558	1	SPINDLE PULLEY SPACER	
22	VH-H561	1	SPINDLE PULLEY HUB	
23	VH-H562	1	TIMING PULLEY CLUTCH SLEEVE	
24	VH-H563	1	TIMING BELT PULLEY	
25	VH-H564	1	BULL GEAR PINION COUNTER SHAFT	
26	VH-H565	1	BEARING CAP	
27	VH-H569	1	COUNTER SHAFT GEAR	
28	VH-H571	1	SPINDLE BULL GEAR ASSEMBLY	
29	VH-H572	1	SPINDLE GEAR HUB	
30	VH-H574	1	BULL GEAR BEARING SLEEVE WASHER	
31	VH-H575	3	SPRING	
32	VH-H576	1	BULL GEAR BEARING SLEEVE	
33	VH-H578	1	BULL GEAR BEARING SPACER	
34	VH-H589	2	GUIDE	

VH-01-P1

PARTS NO.		PC	DESCRIPTION	REMARKS
1	VH-H596	1	SPEED CHANGE PLATE	
2	VH-H597	1	SPEED CHANGE PLATE PIVOT STUD	
3	VH-H599	1	WASHER	
4	VH-H602	1	SPEED CHANGE CHAIN STUD	
5	VH-H605	1	SPEED CHANGE CHAIN DRUM	
6	VH-H607	1	WORM GEAR SHAFT SUPPORTER	
7	VH-H609	1	SPEED CHANGER WORM GEAR	
8	VH-H610	1	BRONZE BEARING	
9	VH-H611	1	LOCK SCREW	
10	VH-H613	1	SPEED CHANGE HOUSING	
11	VH-H616	1	WORM	
12	VH-H658	2	COVER	
13				
14				
15				
16	TM-H001	1	QUILL HOUSING	
17	TM-H008	2	TIMING BELT PULLEY FLANGE	
18	TM-H035	1	QUILL SKIRT	
19	TM-H036	1	QUILL STOP KNOB	
20	TM-H037	1	QUILL STOP MICRO SCREW	
21	TM-H038	1	MICRO METER NUT	
22	TM-H126	1	FEED DRIVE WORM GEAR	
23	TM-H149	1	DRAWBAR WASHER (R8)	
24	TM-H150	2	SOCKET SET SCREW	
25	TM-H157	1	QUILL MICRO STOP NUT	
26	TM-H166	1	SPINDLE	
27	TM-H167	1	QUILL	
28	TM-H169	1	SPINDLE DIRT SHIELD	
29	TM-H172	1	NOSE PIECE	
30	TM-H176	1	SLEEVE	
31				
32				
33				
34				

VH-01-P2

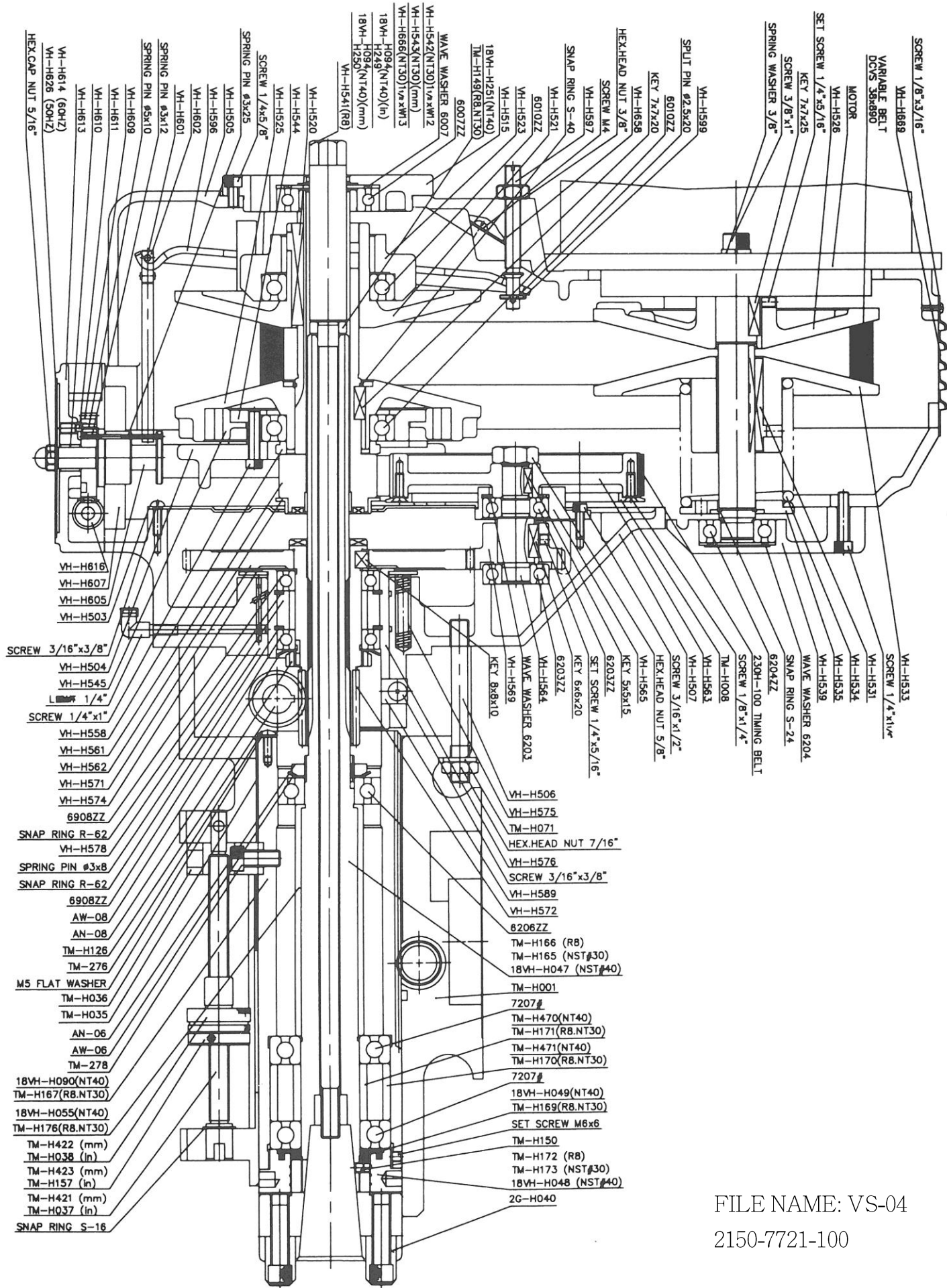

FILE NAME: VS-04

2150-7721-100

PARTS NO.		PC	DESCRIPTION	REMARKS
1	VH-H503	1	GEAR HOUSING PLATE	
2	VH-H504	1	BELT HOUSING (BOTTOM)	
3	VH-H505	1	BELT HOUSING (UP)	
4	VH-H507	1	GEAR HOUSING	
5	VH-H510	1	OIL PLUG	
6	VH-H515	1	TOP BEARING CAP	
7	VH-H521	1	ADJ DRIVEN VARI-DISC ASSEMBLY	
8	VH-H523	1	SLIDING HOUSING	
9	VH-H525	1	STATIONARY DRIVEN VARI-DISC	
10	VH-H541	1	DRAWBAR (R8)	
11	VH-H545	1	BRAKE SHOE	
12	VH-H547	1	BRAKE RING SCREW	
13	VH-H549	2	BRAKE SPRING	
14	VH-H550	2	BRAKE OPERATING FINGER	
15	VH-H551	1	BRAKE FINGER PIVOT STUD	
16	VH-H554	1	BRAKE LOCK CAM	
17	VH-H556	1	BRAKE LOCK SHAFT	
18	VH-H557	1	SLEEVE FOR BRAKE	
19	VH-H558	1	SPINDLE PULLEY SPACER	
20	VH-H561	1	SPINDLE PULLEY HUB	
21	VH-H562	1	TIMING PULLEY CLUTCH SLEEVE	
22	VH-H571	1	SPINDLE BULL GEAR ASSEMBLY	
23	VH-H572	1	SPINDLE GEAR HUB	
24	VH-H576	1	BULL GEAR BEARING SLEEVE	
25	VH-H579	1	BULL GEAR SHIFTER PINION	
26	VH-H580	1	HI-LOW DETENT PLATE	
27	VH-H581	1	HI-LOW PINION BLOCK	
28	VH-H583	1	SPRING	
29	VH-H584	1	HI-LOW DETENT PLUNGER	
30	VH-H585	1	ADJ PLATE	
31	VH-H587	1	HI-LOW SHIFT CRANK	
32	VH-H589	2	GUIDE	
33	VH-H594	2	PIVOT SLEEVE	
34	VH-H596	1	SPEED CHANGE PLATE	

PARTS NO.		PC	DESCRIPTION	REMARKS
1	TM-H607	1	WORM GEAR SHAFT SUPPORTER	
2	TM-H613	1	SPEED CHANGE HOUSING	
3	TM-H616	1	WORM	
4	TM-H617	1	SPEED CONTROL SHAFT	
5	TM-H621	1	BRONZE BEARING	
6	TM-H622	1	SPEED CHANGE HANDWHEEL	
7	TM-H624	1	HANDLE	
8				
9				
10				
11	TM-H092	1	BRAKE LOCK HANDLE	
12	TM-H093	1	BRAKE LOCK PIN	
13	TM-H284	8	BLACK PLASTIC BALL	
14				
15				
16				
17				
18				
19				
20				
21				
22				
23				
24				
25				
26				
27				
28				
29				
30				
31				
32				
33				
34				

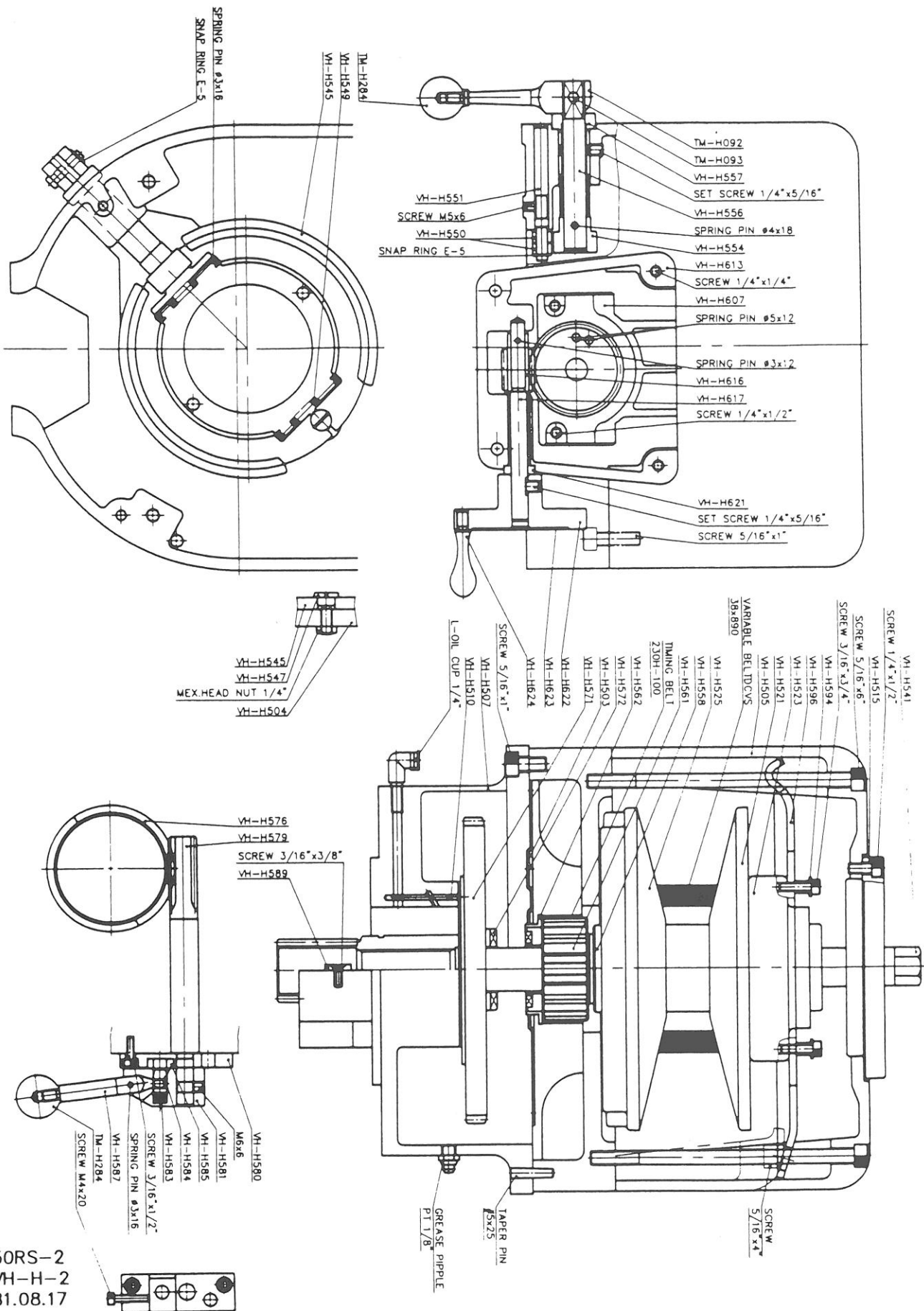

50RS-2
 VH-H-2
 81.08.17