

Duplex starter w/o alternator, Size 3 1/2, Three phase full voltage, Amb. compensate bimetal OLR, Contactor amp rating 115A, 208VAC 60Hz coil, Combination type, Two 125A circuit breakers, Enclosure NEMA type 1, Indoor general purpose use



Figure similar

Product brand name	Class 84
Design of the product	Duplex controller with two MCPs without alternator
Special product feature	Half-size controller

General technical data	
Weight [lb]	106 lb
Height x Width x Depth [in]	56 × 29 × 10 in
Protection against electrical shock	NA for enclosed products
Installation altitude [ft] at height above sea level maximum	6560 ft
Ambient temperature [°F]	
• during storage maximum	149 °F
• during operation maximum	104 °F
Ambient temperature	
• during storage maximum	65 °C
• during operation maximum	40 °C
Country of origin	USA

Horsepower ratings

Yielded mechanical performance [hp] for three-phase AC motor	
<ul style="list-style-type: none"> • at 200/208 V rated value 	30 hp
<ul style="list-style-type: none"> • at 220/230 V rated value 	40 hp
<ul style="list-style-type: none"> • at 460/480 V rated value 	75 hp
<ul style="list-style-type: none"> • at 575/600 V rated value 	75 hp

Contactors

Size of contactor	Controller half size 3 1/2
Number of NO contacts for main contacts	3
Operating voltage for main current circuit at AC at 60 Hz maximum	600 V
Operating current at AC at 600 V rated value	115 A
Mechanical service life (switching cycles) of the main contacts typical	5000000

Auxiliary contact

Number of NC contacts at contactor for auxiliary contacts	0
Number of NO contacts at contactor for auxiliary contacts	1
Number of total auxiliary contacts maximum	7
Contact rating of auxiliary contacts of contactor according to UL	10A@600VAC (A600), 5A@600VDC (P600)

Coil

Type of voltage of the control supply voltage	AC
Control supply voltage	
<ul style="list-style-type: none"> • at DC rated value 	0 ... 0 V
<ul style="list-style-type: none"> • at AC at 50 Hz rated value 	0 ... 0 V
<ul style="list-style-type: none"> • at AC at 60 Hz rated value 	208 ... 208 V
Holding power at AC minimum	14 W
Apparent pick-up power of magnet coil at AC	310 V·A
Apparent holding power of magnet coil at AC	26 V·A
Operating range factor control supply voltage rated value of magnet coil	0.85 ... 1.1
Percental drop-out voltage of magnet coil related to the input voltage	50 %
Switch-on delay time	26 ... 41 ms
Off-delay time	14 ... 19 ms

Overload relay

Product function	
<ul style="list-style-type: none"> • Overload protection 	Yes
<ul style="list-style-type: none"> • Test function 	Yes
<ul style="list-style-type: none"> • External reset 	Yes

Reset function	Manual and automatic
Adjustment range of thermal overload trip unit	0.85 ... 1.15
Number of NC contacts of auxiliary contacts of overload relay	3
Number of NO contacts of auxiliary contacts of overload relay	0
Operating current of auxiliary contacts of overload relay	
• at AC at 600 V	5 A
• at DC at 250 V	5 A
Contact rating of auxiliary contacts of overload relay according to UL	5A@600VAC (B600), 5A@250VDC (P300)

Enclosure

Degree of protection NEMA rating of the enclosure	NEMA Type 1
Design of the housing	Indoor general purpose use

Motor Circuit Protector (magnetic trip only)

Operating current of motor circuit breaker rated value	125 A
Adjustable pick-up value current of instantaneous short-circuit trip unit	500 ... 1250 A

Mounting/wiring

Mounting position	Vertical
Mounting type	Surface mounting and installation
Type of electrical connection for supply voltage line-side	Box lug
Type of connectable conductor cross-sections at line-side at AWG conductors single or multi-stranded	1x (10 AWG ... 1/0 AWG)
Temperature of the conductor for supply maximum permissible	75 °C
Material of the conductor for supply	AL or CU
Type of electrical connection for load-side outgoing feeder	Screw-type terminals
Tightening torque [lbf-in] for load-side outgoing feeder	35 ... 50 lbf-in
Type of electrical connection of magnet coil	Screw-type terminals
Tightening torque [lbf-in] at magnet coil	5 ... 12 lbf-in
Type of connectable conductor cross-sections of magnet coil at AWG conductors single or multi-stranded	2x (16 ... 12 AWG)
Temperature of the conductor at magnet coil maximum permissible	75 °C
Material of the conductor at magnet coil	CU
Type of electrical connection at contactor for auxiliary contacts	Screw-type terminals

Tightening torque [lbf-in] at contactor for auxiliary contacts	10 ... 15 lbf-in
Type of connectable conductor cross-sections at contactor at AWG conductors for auxiliary contacts single or multi-stranded	1x (12 AWG), 2x (16 ... 14 AWG), 2x (18 ... 16 AWG)
Temperature of the conductor at contactor for auxiliary contacts maximum permissible	75 °C
Material of the conductor at contactor for auxiliary contacts	CU
Type of electrical connection at overload relay for auxiliary contacts	Screw-type terminals
Tightening torque [lbf-in] at overload relay for auxiliary contacts	5 ... 12 lbf-in
Type of connectable conductor cross-sections at overload relay at AWG conductors for auxiliary contacts single or multi-stranded	2x (16 ... 12 AWG)
Temperature of the conductor at overload relay for auxiliary contacts maximum permissible	75 °C
Material of the conductor at overload relay for auxiliary contacts	CU

Short-circuit current rating

Design of the short-circuit trip	Instantaneous trip circuit breaker
Maximum short-circuit current breaking capacity (Icu) <ul style="list-style-type: none"> • at 240 V • at 480 V • at 600 V 	100 kA 100 kA 25 kA
Certificate of suitability	NEMA ICS 2; UL 508; CSA 22.2, No.14

Further information

Industrial Controls - Product Overview (Catalogs, Brochures,...)

www.usa.siemens.com/iccatalog

Industry Mall (Online ordering system)

<https://mall.industry.siemens.com/mall/en/us/Catalog/product?mlfb=US2:84IPL95BMD81>

Service&Support (Manuals, Certificates, Characteristics, FAQs,...)

<https://support.industry.siemens.com/cs/US/en/ps/US2:84IPL95BMD81>

Image database (product images, 2D dimension drawings, 3D models, device circuit diagrams, EPLAN macros, ...)

http://www.automation.siemens.com/bilddb/cax_de.aspx?mlfb=US2:84IPL95BMD81&lang=en

Certificates/approvals

<https://support.industry.siemens.com/cs/US/en/ps/US2:84IPL95BMD81/certificate>

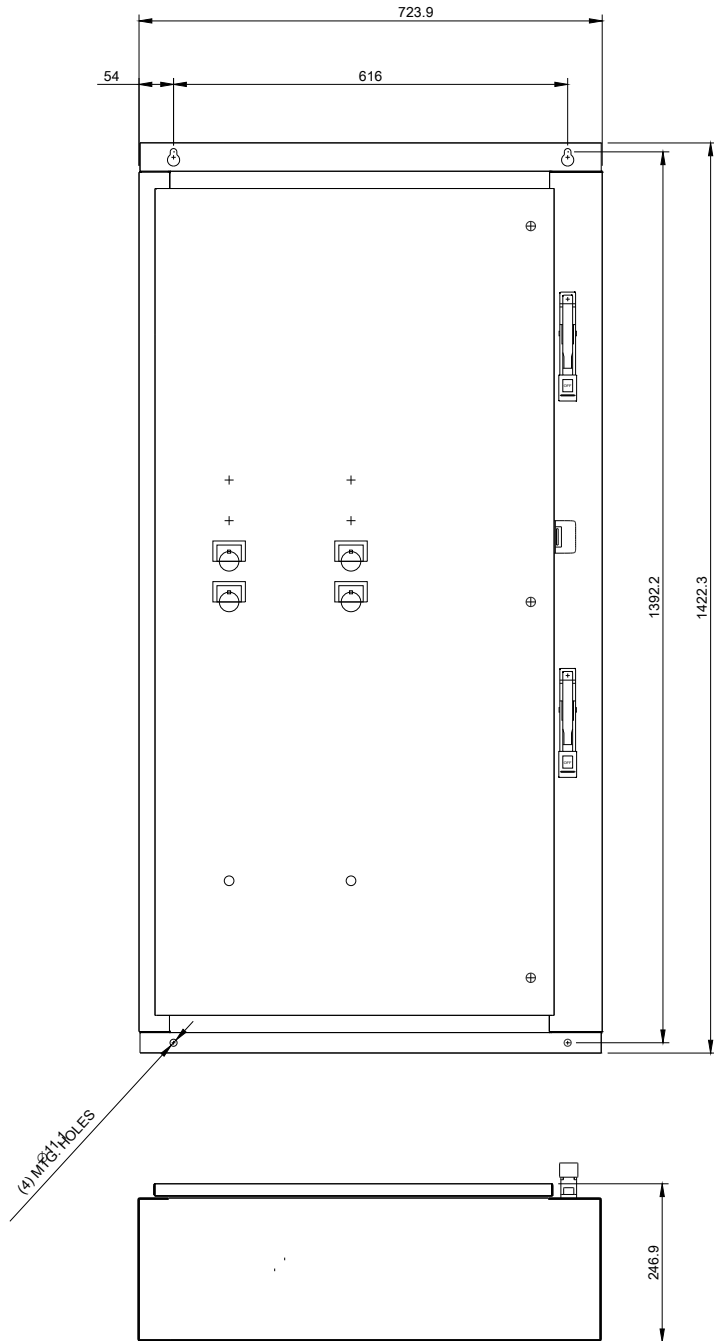

%%USCHEMATIC DIAGRAM

Class 83 & 84 Duplex W/Manual Alternation Size 0-4

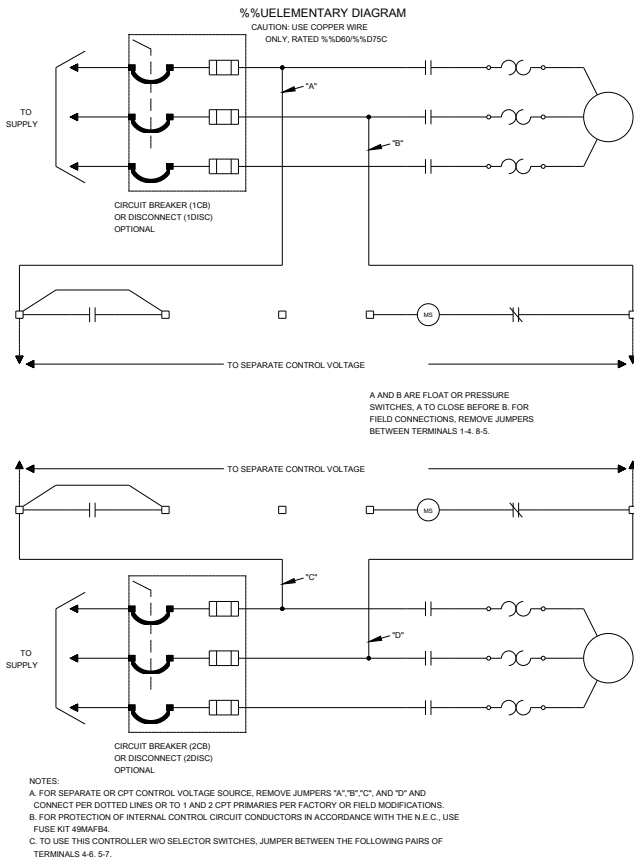

D68077003

last modified:

11/16/2019