

OPER

TOOLS

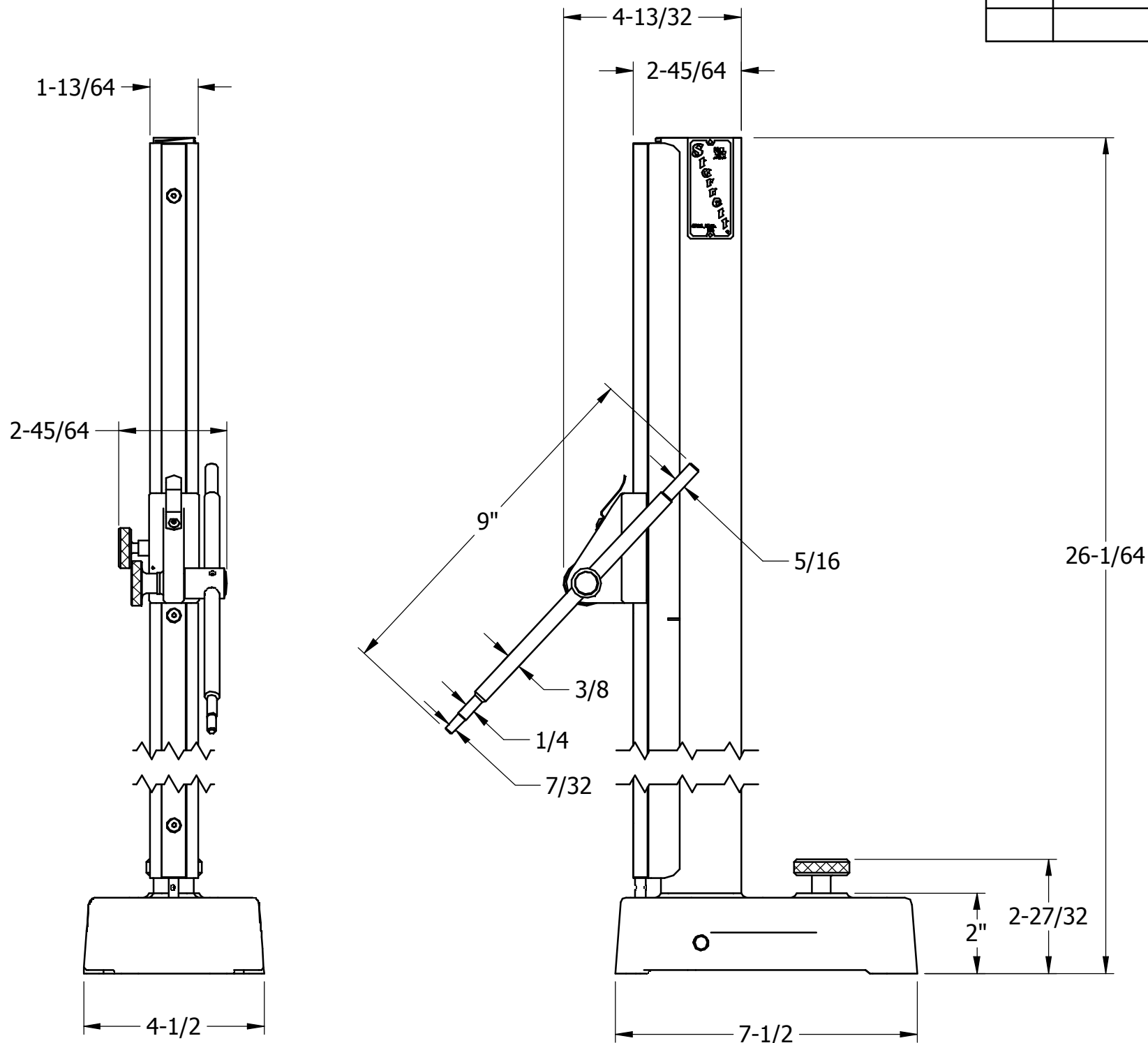

REV	DESCRIPTION	DATE	BY
DR	APU	CHK	DATE

**HEIGHT TRANSFER GAGE
ASSEMBLY**

THE L.S. STARRETT CO.
ATHOL, MASS.

FRACTIONAL TOLERANCE $\pm 1/64$ UNLESS OTHERWISE NOTED