

SH. 1  
OF 1

CAT NO

25-631J

CUSTOMER DIMENSIONS

DO NOT  
SEPARATE  
PRINT FROM  
WORK

LOT NO

OPER

TOOLS

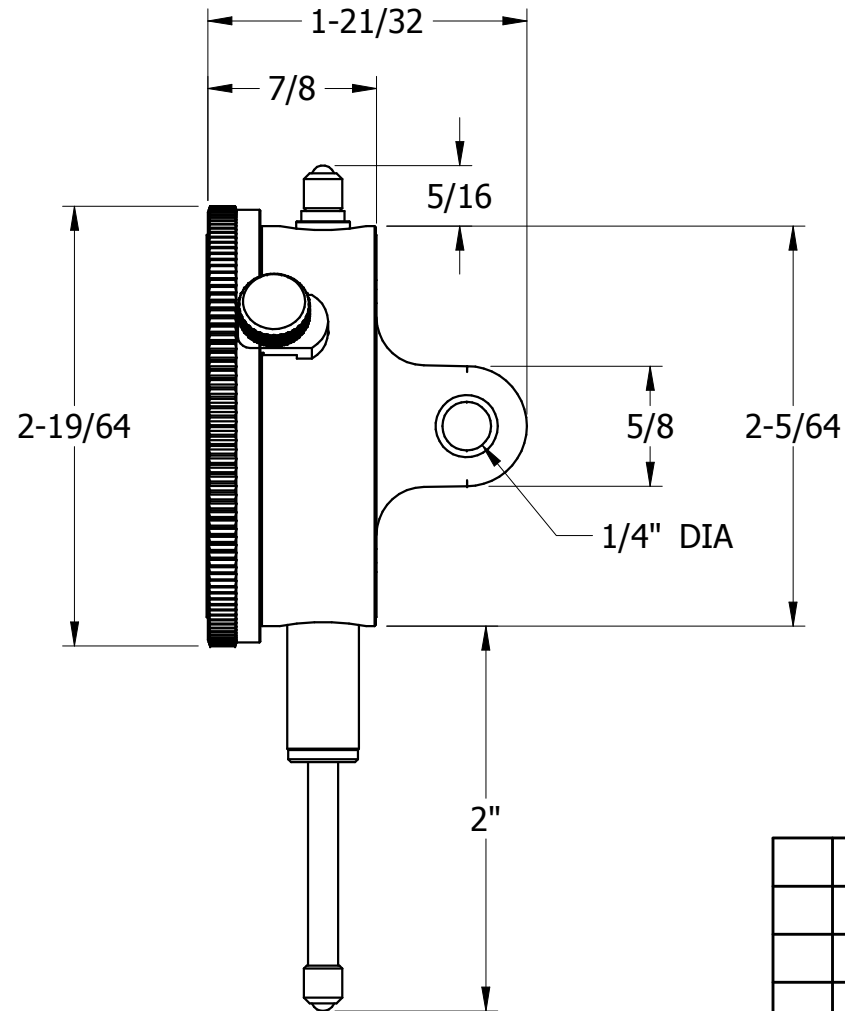
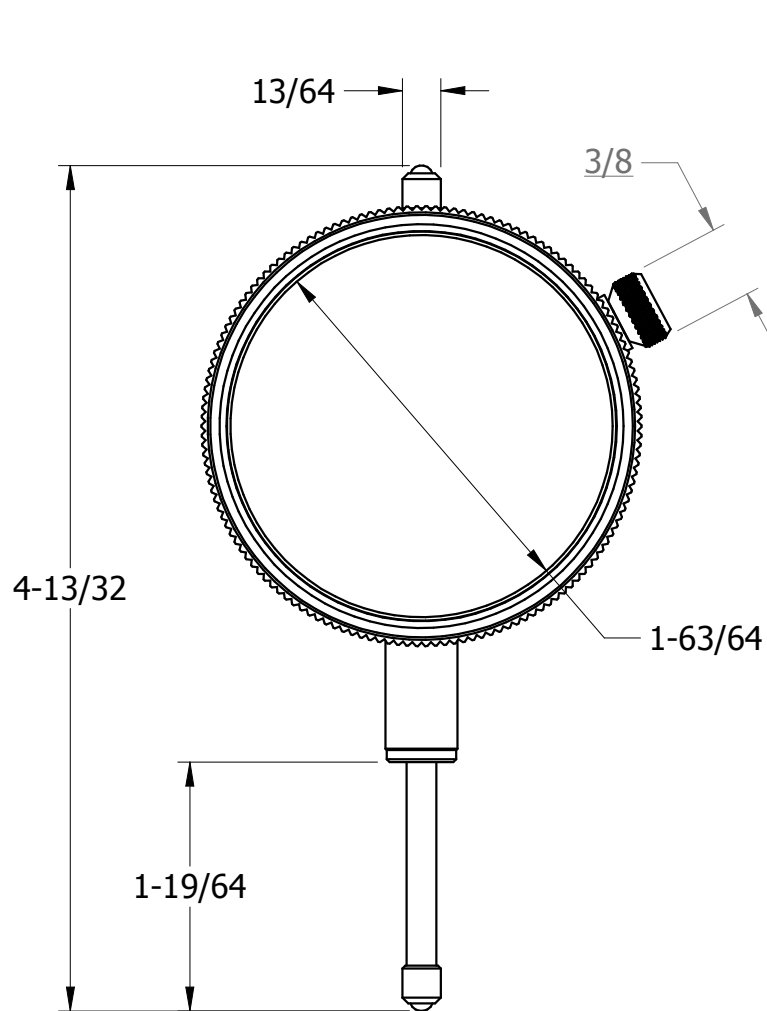

REV	DESCRIPTION	DATE	BY
DR	DRH	CHK	DATE

DIAL INDICATOR

THE L.S. STARRETT CO.  
ATHOL, MASS.

FRACTIONAL TOLERANCE +- 1/64 UNLESS OTHERWISE NOTED