

SH. 1
OF 1

CAT NO

289B

CUSTOMER DIMENSIONS

DO NOT
SEPARATE
PRINT FROM
WORK

LOT NO

OPER

TOOLS

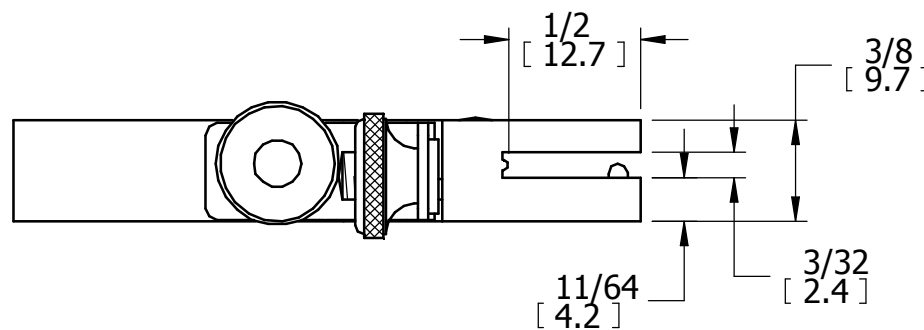
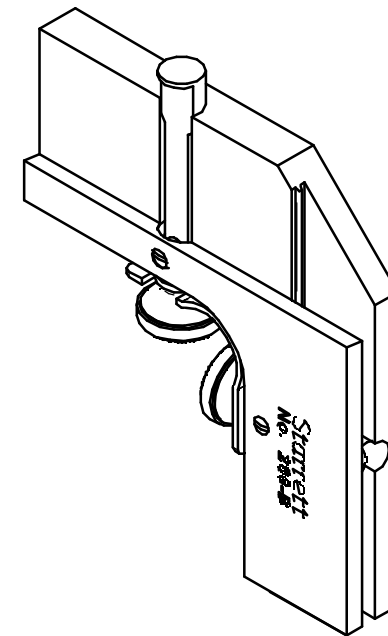
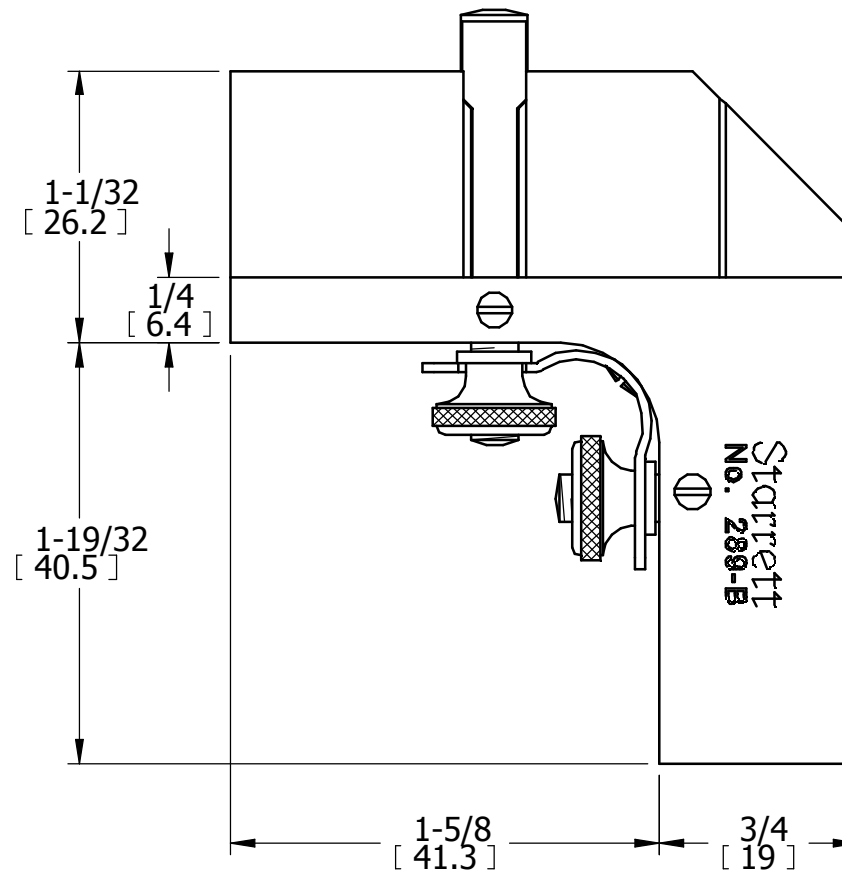
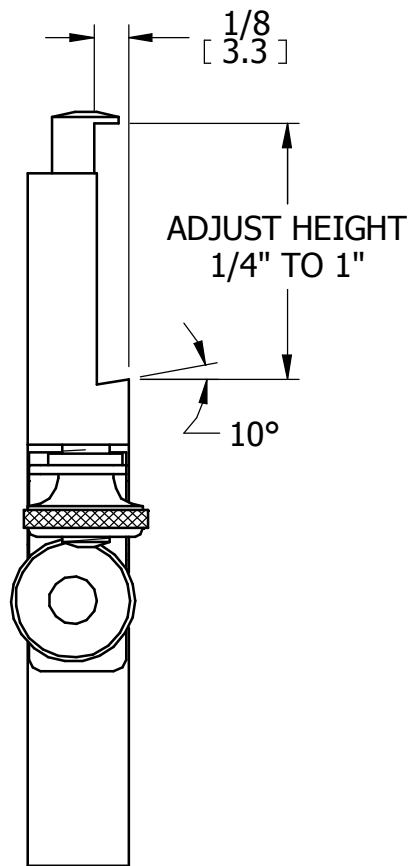

| | | | |
|--|--|--|--|
| | | | |
| | | | |
| | | | |
| | | | |
| | | | |
| | | | |
| | | | |
| | | | |

| REV | DESCRIPTION | DATE | BY |
|-----|-------------|------|------|
| DR | JG | CHK | DATE |

**ATTACHMENT FOR
COMBINATION SQUARE**

**THE L.S. STARRETT CO.
ATHOL, MASS.**

FRACTIONAL TOLERANCE +- 1/64 UNLESS OTHERWISE NOTED