

SH. 1  
OF 1

CAT NO

445AZ-9RL

CUSTOMER DIMENSIONS

DO NOT  
SEPARATE  
PRINT FROM  
WORK

LOT NO

OPER

TOOLS

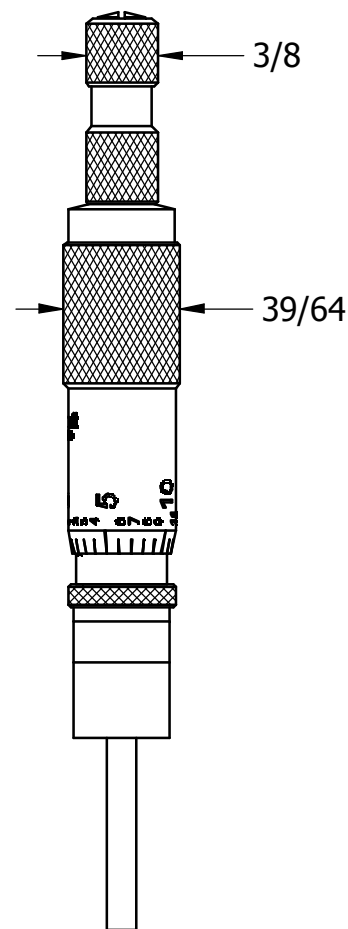
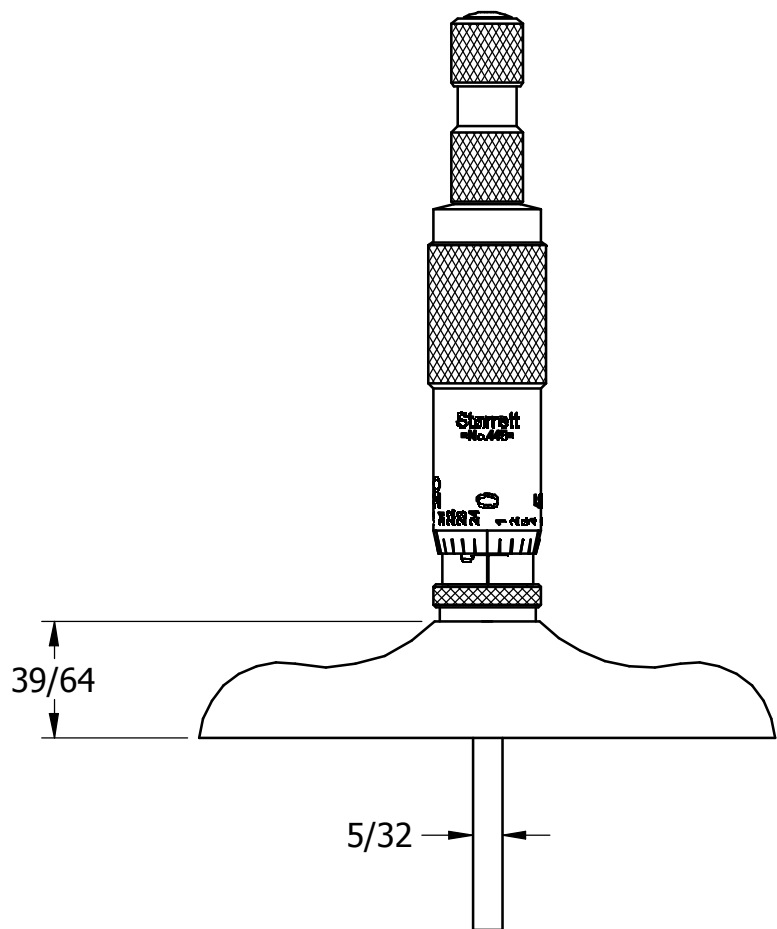
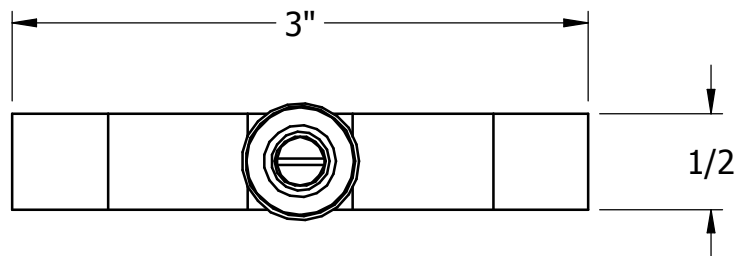

|  |  |  |  |
|--|--|--|--|
|  |  |  |  |
|  |  |  |  |
|  |  |  |  |
|  |  |  |  |
|  |  |  |  |
|  |  |  |  |
|  |  |  |  |
|  |  |  |  |

| REV | DESCRIPTION | DATE | BY   |
|-----|-------------|------|------|
| DR  | JAC         | CHK  | DATE |

MICROMETER DEPTH GAGE  
ASSEMBLY

THE L.S. STARRETT CO.  
ATHOL, MASS.

FRACTIONAL TOLERANCE +- 1/64 UNLESS OTHERWISE NOTED