

SH. 1
OF 1

CAT NO

466

CUSTOMER DIMENSIONS

DO NOT
SEPARATE
PRINT FROM
WORK

LOT NO

OPER

TOOLS

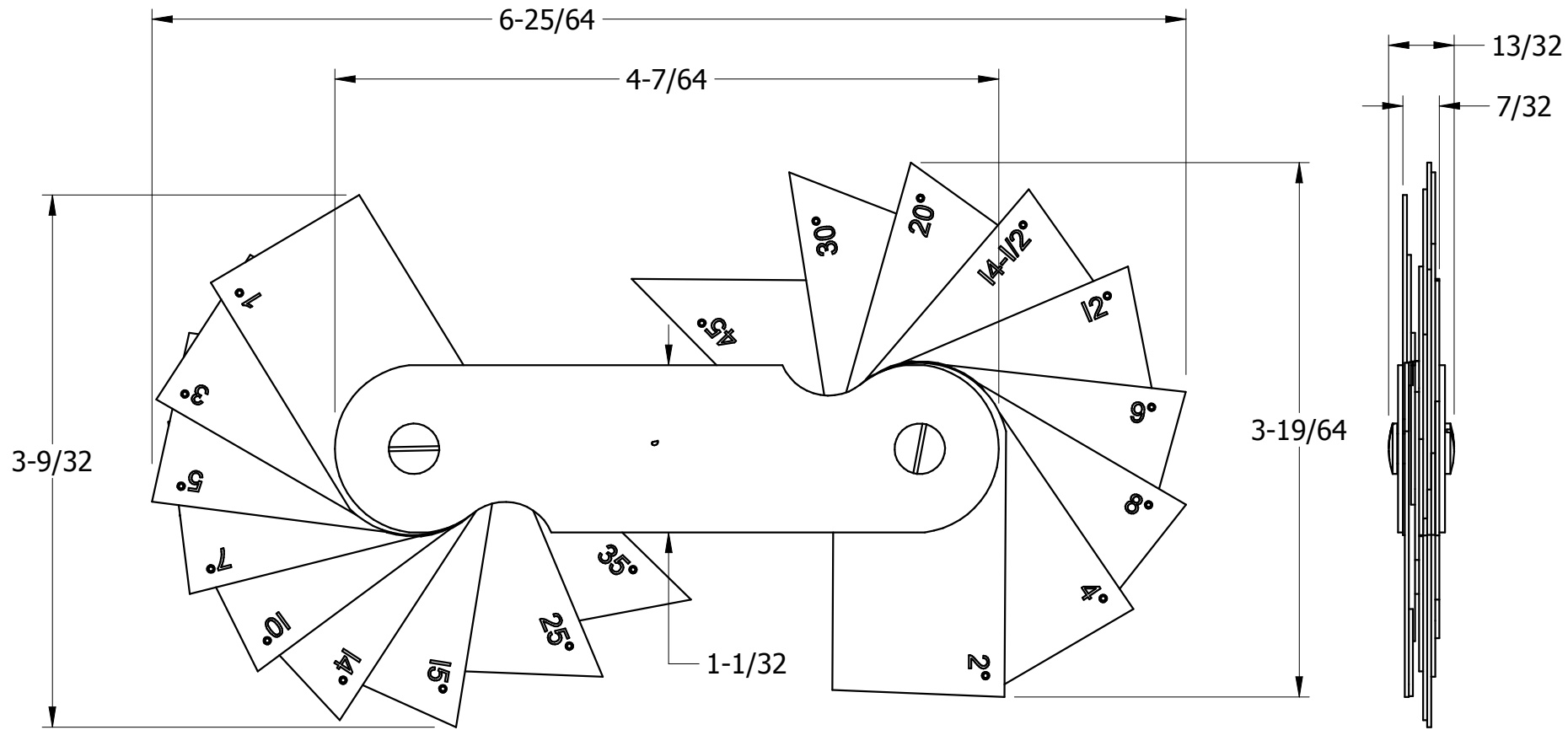

REV	DESCRIPTION	DATE	BY
-----	-------------	------	----

DR	H.L.S.	CHK	DATE
----	--------	-----	------

**ANGLE GAUGE
ASSEMBLY**

FRACTIONAL TOLERANCE $\pm 1/64$ UNLESS OTHERWISE NOTED

THE L.S. STARRETT CO.
ATHOL, MASS.