

SH. 1
OF 1

CAT NO

649-1M

CUSTOMER DIMENSIONS

DO NOT
SEPARATE
PRINT FROM
WORK

LOT NO

OPER

TOOLS

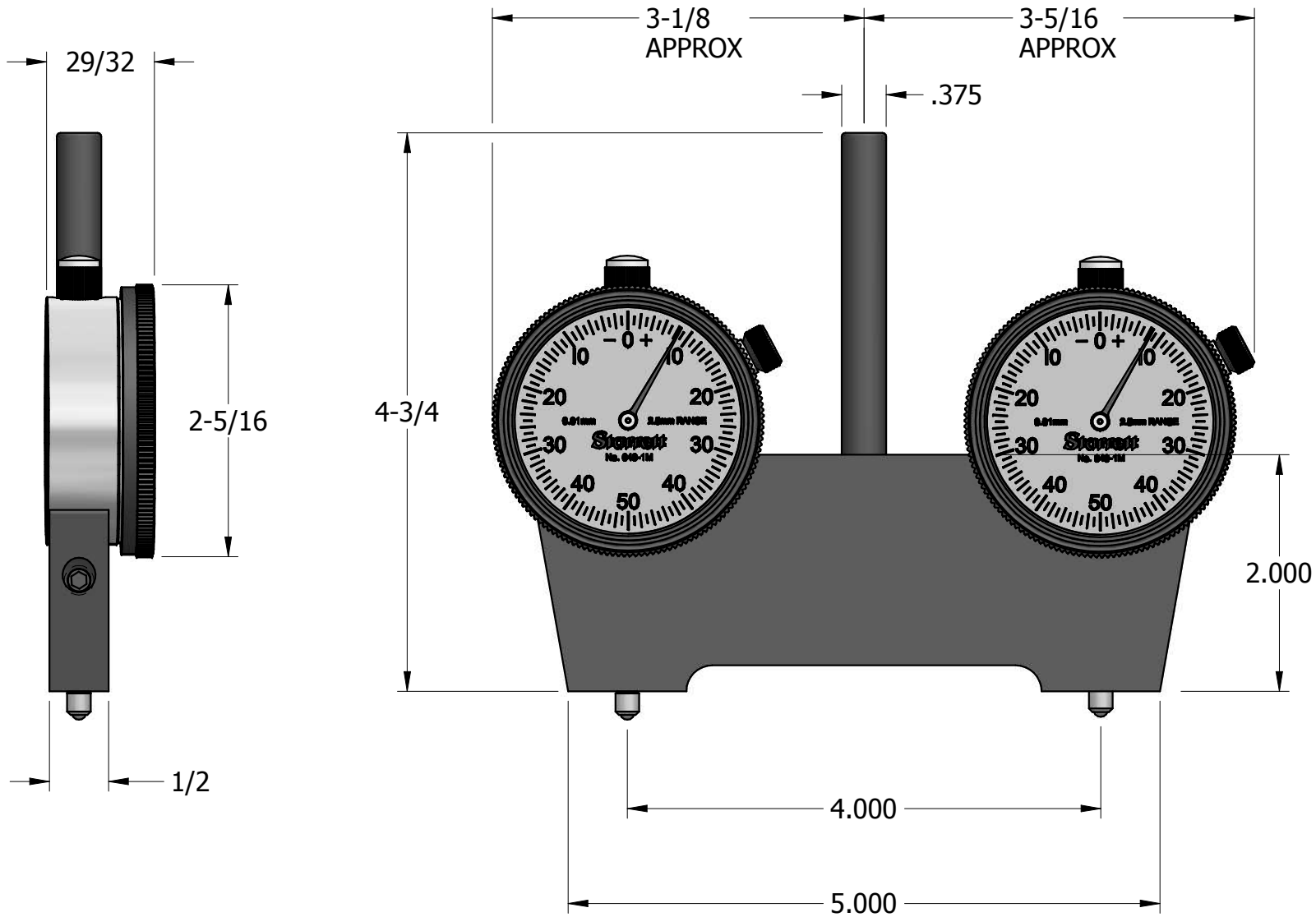

REV	DESCRIPTION	DATE	BY
DR	CAP	CHK	DATE 5/22/15

SPECIAL FUNCTION INDICATOR
SPINDLE SQUARE

FRACTIONAL TOLERANCE +/- 1/64 UNLESS OTHERWISE NOTED

THE L.S. STARRETT CO.
ATHOL, MASS.