

SH. 1
OF 1

CAT NO

828D

CUSTOMER DIMENSIONS

DO NOT
SEPARATE
PRINT FROM
WORK

LOT NO

OPER

TOOLS

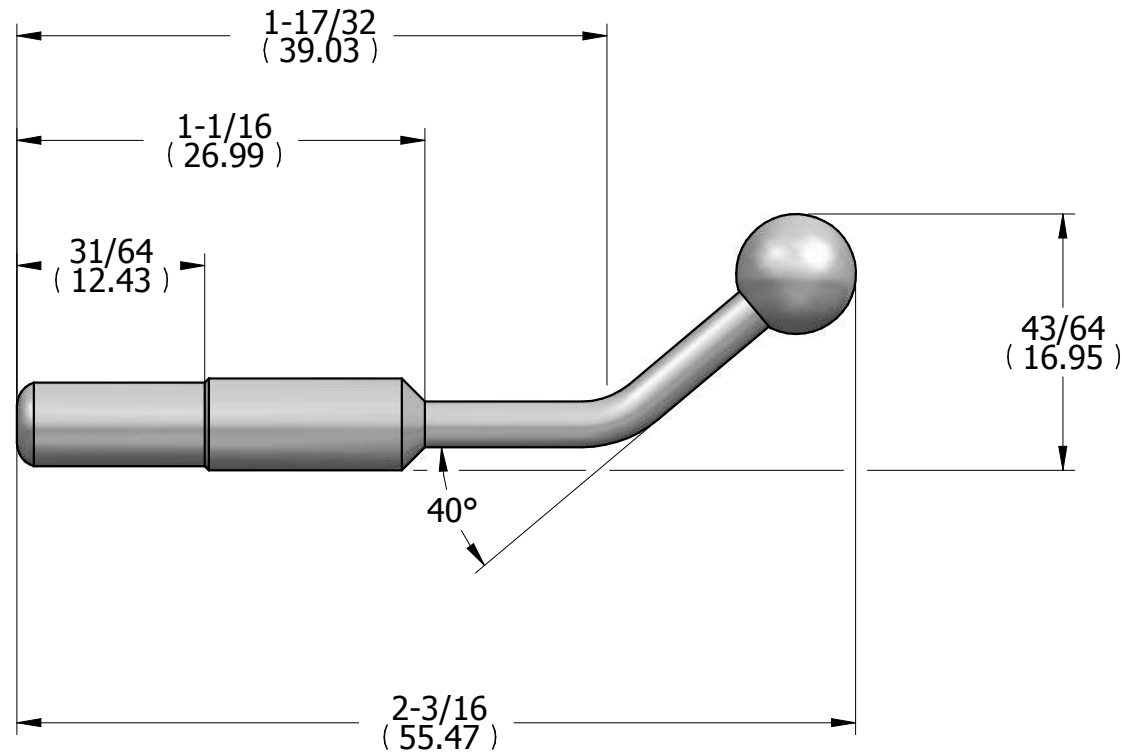
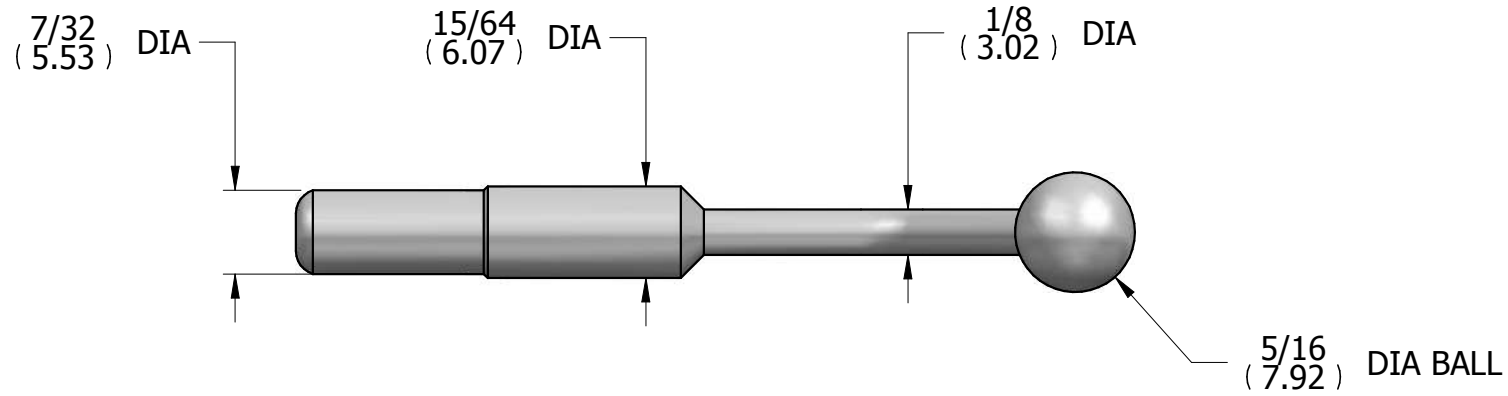

REV	DESCRIPTION	DATE	BY
-----	-------------	------	----

DR	DSP	CHK	DATE
----	-----	-----	------

OFFSET INDICATOR
HOLDER

THE L.S. STARRETT CO.
ATHOL, MASS.

FRACTIONAL TOLERANCE +- 1/64 UNLESS OTHERWISE NOTED