

SH. 1  
OF 1

CAT NO

82A5

CUSTOMER DIMENSIONS

DO NOT  
SEPARATE  
PRINT FROM  
WORK

LOT NO

OPER

TOOLS

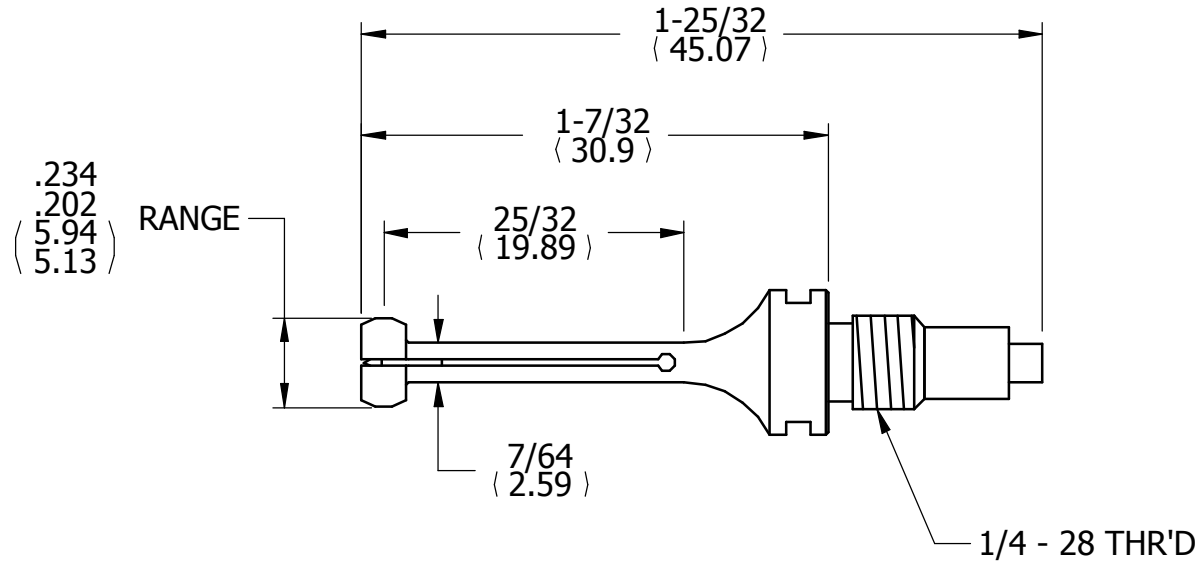
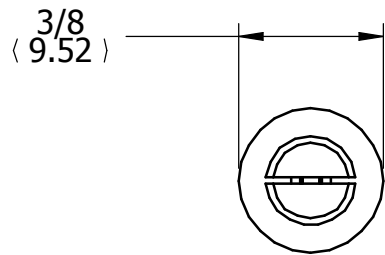

REV	DESCRIPTION	DATE	BY
-----	-------------	------	----

DR	DSP	CHK	DATE
----	-----	-----	------

**PROBE/ACTUATOR  
ASSEMBLY**

FRACTIONAL TOLERANCE +- 1/64 UNLESS OTHERWISE NOTED

**THE L.S. STARRETT CO.  
ATHOL, MASS.**