

OPER

TOOLS

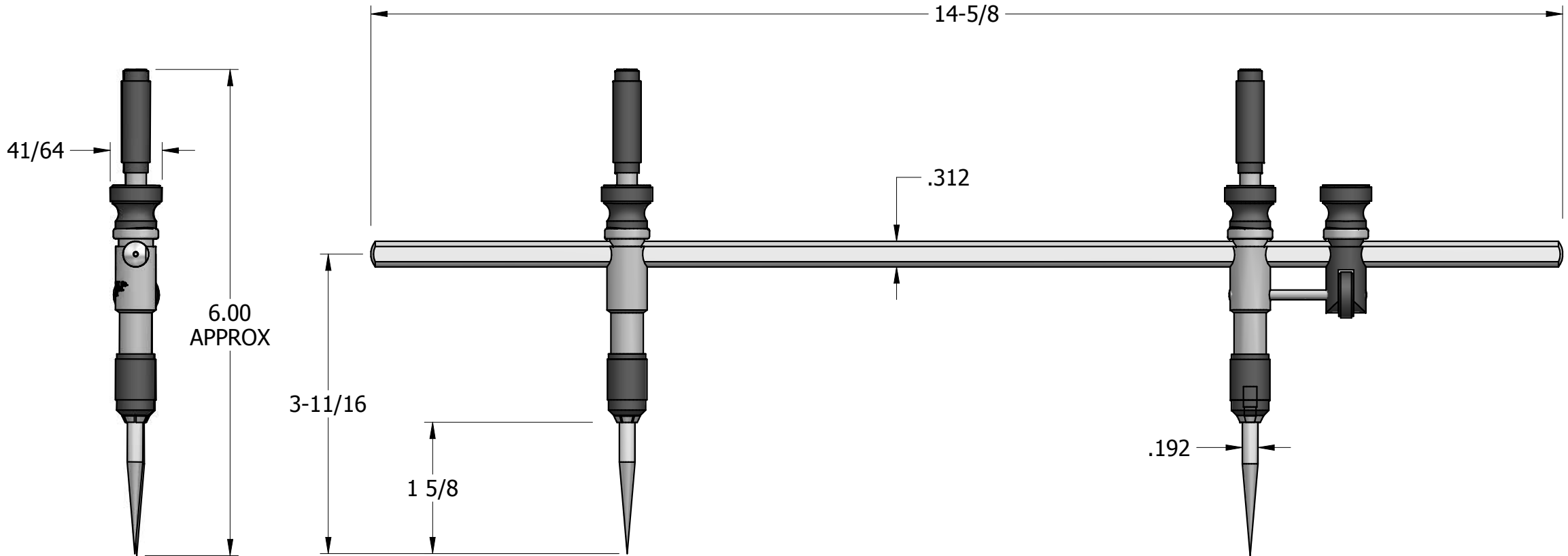

MAX DIVIDING RANGE = 13-1/2" (338mm)  
MAX CIRCLE DIA RANGE = 26" (650mm)

REV	DESCRIPTION	DATE	BY
DR	CAP	CHK	DATE 2/27/15

STEEL BEAM TRAMMEL  
ASSEMBLY

THE L.S. STARRETT CO.  
ATHOL, MASS.

FRACTIONAL TOLERANCE +- 1/64 UNLESS OTHERWISE NOTED