

SH. 1
OF 1

CAT NO

PT06632-15

CUSTOMER DIMENSIONS

DO NOT
SEPARATE
PRINT FROM
WORK

LOT NO

OPER

TOOLS

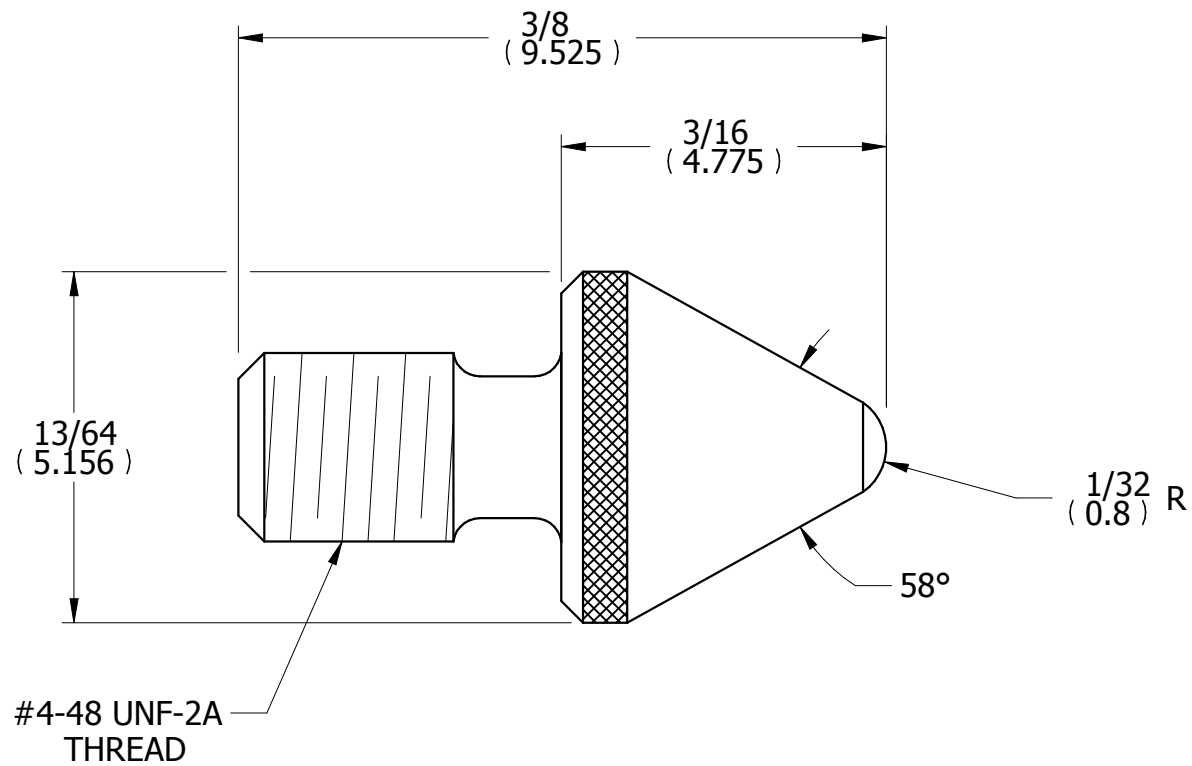

REV	DESCRIPTION	DATE	BY
DR	J.A.E.	CHK	DATE 10/8/15

DIAL INDICATOR
ANVIL

FRACTIONAL TOLERANCE +- 1/64 UNLESS OTHERWISE NOTED

THE L.S. STARRETT CO.
ATHOL, MASS.