

SH. 1  
OF 1

CAT NO

PT07101F

CUSTOMER DIMENSIONS

DO NOT  
SEPARATE  
PRINT FROM  
WORK

LOT NO

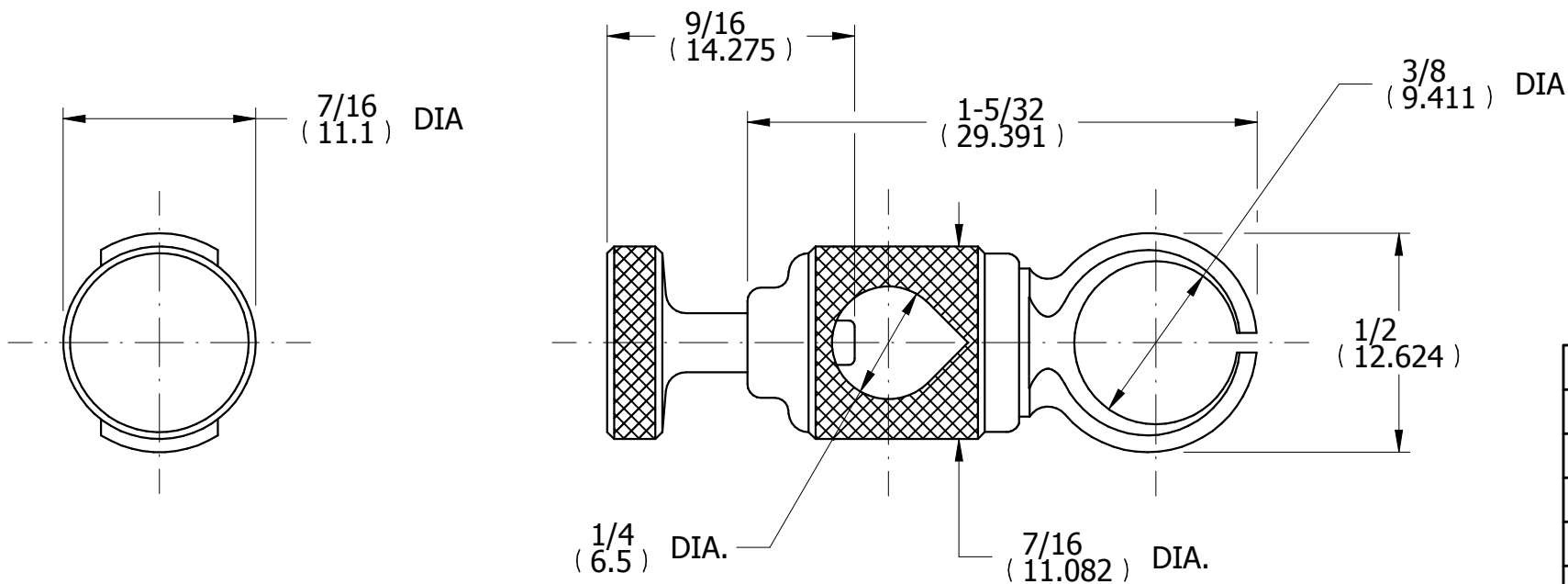
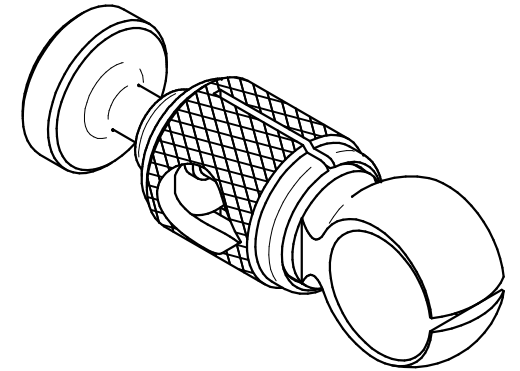
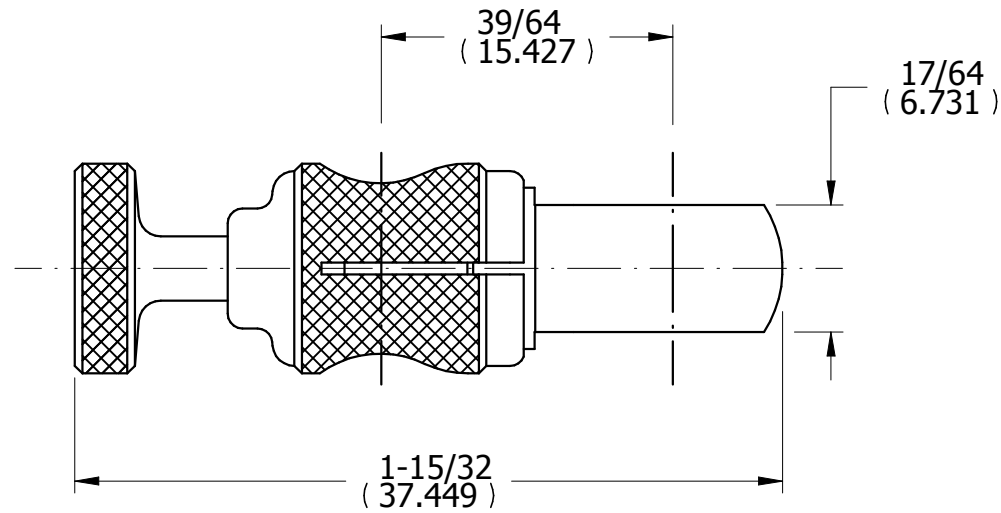

REV	DESCRIPTION	DATE	BY
DR	JMR	CHK	DATE 5/18/16

**BODY CLAMP FOR  
CAT. 711 INDICATOR**

**THE L.S. STARRETT CO.  
ATHOL, MASS.**

FRACTIONAL TOLERANCE +- 1/64 UNLESS OTHERWISE NOTED