

SH. 1  
OF 1

CAT NO

T483XRL-2

CUSTOMER DIMENSIONS

DO NOT  
SEPARATE  
PRINT FROM  
WORK

LOT NO

OPER

TOOLS

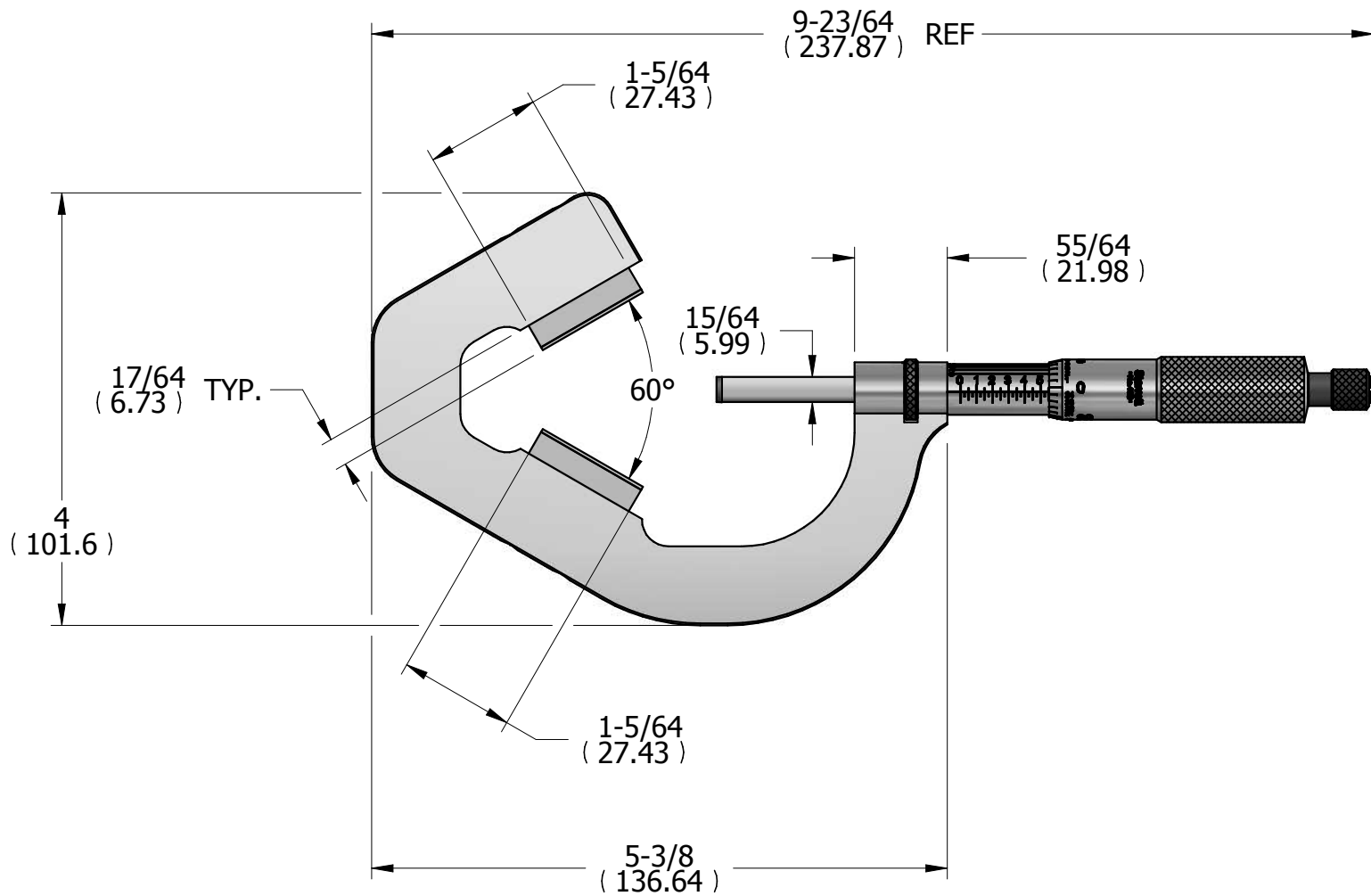
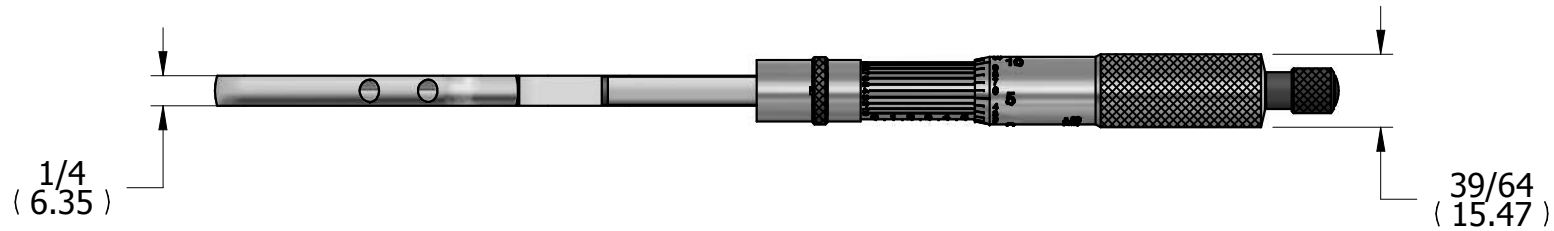

REV	DESCRIPTION	DATE	BY
DR	CAP	CHK	DATE

V-ANVIL MICROMETER  
RANGE 1 - 2"

THE L.S. STARRETT CO.  
ATHOL, MASS.

FRACTIONAL TOLERANCE +/- 1/64 UNLESS OTHERWISE NOTED