

SYLVANIA SMART⁺ ZigBee[®] Edge-Lit Panel

Adjustable White Fixture



Experience intelligent, connected lighting solutions with SYLVANIA SMART⁺ connected lights and accessories. Using a ZigBee compatible automation hub, easily set up your devices to accommodate your daily routine by creating schedules and automations that fit your project requirements. Our ZigBee smart lighting products can be combined with many other ZigBee devices and platforms to build the ultimate smart automation system.

Application Information

Application Notes

1. SMART⁺ Edge-Lit Panel requires ZigBee compatible automation hub (sold separately)
2. Product activation requires active ZigBee compatible automation hub
3. 5-year limited product warranty
4. Operating temperature range between -4°F and +104°F (-20°C and +40°C)
5. Suitable for use in dry location only
6. Not intended for use with dimmers, emergency light fixtures or exit lights
7. Lamp dims via wireless control and will not operate with a dimmer switch; remove all existing dimmers and replace with a regular switch; leave lamp in ON position
8. Installation: Junction box is mounted on back of panel with knock outs for input wiring. Lay in recessed ceiling applications on non-insulated standard 15/16" T-grid
9. To prevent product malfunction and/or electrical shock this product must be properly grounded

*Above features are currently exclusive to Amazon Echo Plus

This device complies with part 15 of the FCC Rules. Operation is subject to the following two conditions: (1) This device may not cause harmful interference, and (2) this device must accept any interference received, including interference that may cause undesired operation. For FCC Part 15 user information, please see www.sylvania.com/fcc15b.

**LED Lamp lifetime is defined as the number of hours when 50% of a large group of identical lamps reaches 70% of its initial lumens.

Key Features & Benefits

- SMART⁺ commercial lighting is controlled by smartphone or tablet, as well as through voice integration* and select Leviton[®] products
- Create schedules and light scenes to enhance your experience. Group lights to control them all at once
- SMART⁺ System is controllable locally or on the go*
- Available in 2x2ft and 2x4ft sizes
- Glare free Edge-Lit LED technology
- On/Off/Dimming functions
- LED lamp adjustable between soft white, bright white, and daylight white
- Color temperature tunable between 2700-5000 Kelvin
- Life: 50,000 hours rated life**
- CRI 80+

Product Offering

Ordering Abbreviation	Wattage	CCT	Contains
SMART ⁺ Edge-Lit Panel 2x2 ADJW	32	2700-5000K	1 Edge-Lit LED Panel
SMART ⁺ Edge-Lit Panel 2x4 ADJW	40	2700-5000K	1 Edge-Lit LED Panel

Specifications and Certifications



Contains:
FCC ID: DZO-LDV-AETHER
IC: 11099A-LDVAETHER



Works with Echo Plus



Specification Data

Catalog #	Type
Project	
Comments	
Prepared by	

Ordering Information

Item Number	Ordering Description	Wattage	Lumens	Voltage	CCT	CRI	Life
74746	LEDPANEL32WADJW22ZBS+	32	3200	120-277	2700-5000K	80+	50,000
74523	LEDPANEL40WADJW24ZBS+	40	4000	120-277	2700-5000K	80+	50,000

Ordering Guide

LED	PANEL	XX	ADJW	XX	ZB	S+
LED	Lamp Type Edge-Lit Panel	Wattage 32W, 40W	Adjustable White	Dimensions 2x2ft, 2x4ft	ZigBee	SMART+

Lamp Dimensions

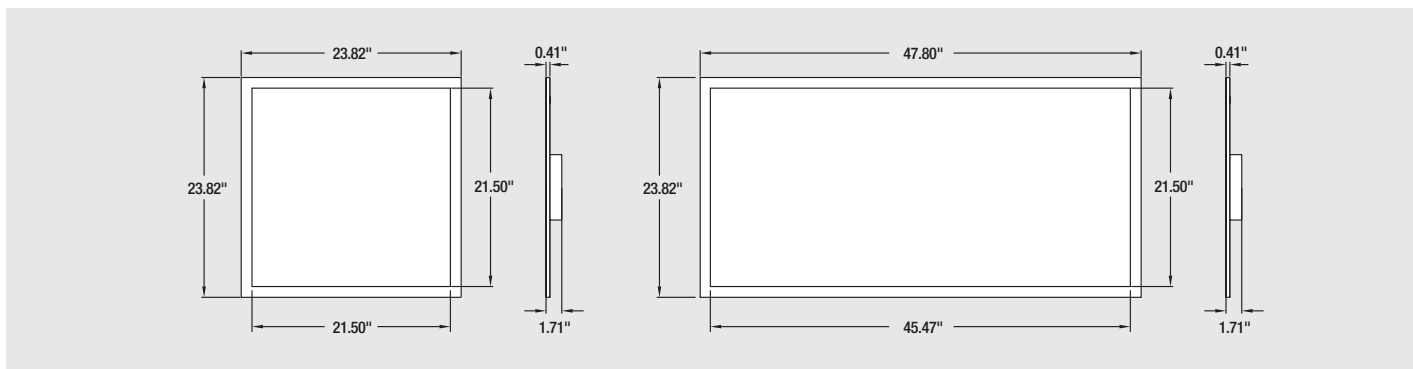

LEDVANCE LLC
 200 Ballardvale Street
 Wilmington, MA 01887 USA
 Phone 1-800-LIGHTBULB (1-800-544-4828)
www.sylvania.com

SYLVANIA and LEDVANCE are registered trademarks.
 All other trademarks are those of their respective owners.
 Licensee of product trademark SYLVANIA in general lighting.
 Specifications subject to change without notice.

[/sylvania](https://twitter.com/sylvania) [/sylvania](https://facebook.com/sylvania)

