

X.treme INOX

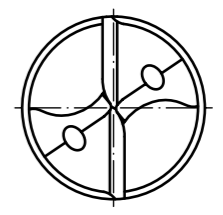
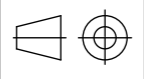

Characteristics:	
No. of flutes	2
Direction of cut	right
Standard	DIN 6537 K
Shank	DIN 6535-HA 14
Type of tool	X.treme INOX

Qty.	Description	Det.	Dwg. No.	Material	Scale: 2:1	Format: A3
Proprietary Information DIN ISO 16016:2002-5				We reserve all Rights to this drawing including for the purpose of issuing patents and registration of petty patents. Without our written consent this drawing may not be copied, whole or partially, and may not be misused by the recipient as well as third parties. Any infraction will result in compensation for occurred damages and could lead to legal action by the author.		
						
				Material: K30F Surface: TTP		
				Description: <b>X.treme INOX</b> 12.5 60 / 107		
				Drawing-No.: <b>1A3293-6287534</b>		
				D10		
				Ord.-Code: <b>A3293TTP-12.5</b>		
Rev.	Revision	Date	Name	Cust. No.:		