

Indexable Milling

Indexable Milling Introduction..... E2-E19

Face Mills F1-F60

90° Shoulder Mills..... G1-G61

Helical Mills..... H1-H11

Slotting Mills I1-I19

Copy Mills..... J1-J98





NEW PRODUCTS

Our latest metalcutting innovations are designed to deliver higher productivity, longer tool life, and increased application versatility.

For more information about the latest products and services from WIDIA™, please contact your WIDIA Representative or Authorised WIDIA Distributor, or visit widia.com.

Victory™ Milling Grades

- WP40PM™ — New best-in-class Victory milling grade for machining steel materials in ISO material group P40 in rough milling applications.
- WK15CM™ — New milling grade for cast irons for higher tool life and increased productivity.
- WS30PM™ — A new high-performance milling grade for machining titanium and stainless steels.



VSM11™

- Step down capabilities.
- Effective internal coolant supply for screw-on, end mill, and shell mill cutters.
- The max ramp angle for VSM11 is 10°.





VSM490™

- Four cutting edges on a double-sided strong insert.
- Lower cutting forces; high-positive geometry.
- Excellent wall and surface finish capabilities.
- When using multiple steps, this is a “stepless” solution.



VSM17™

- Depth-of-cut capabilities up to 16,3mm.
- Step down capabilities.
- Effective internal coolant supply for screw-on, end mill, and shell mill cutters.



The Most Advanced Milling Solutions in the Industry

For unsurpassed quality, value, and performance, you can trust WIDIA™ to provide the most comprehensive line of reliable metalcutting tools. Whatever your indexable milling product requirements, be assured that you will find the appropriate solution in this all-inclusive, easy-to-use guide.

For every milling application, workpiece, or equipment need, we offer the best tools on the market, designed to reduce your machining time, provide superior surface finishes, and outperform the competition.



You can also use our NOVO app to guide you to the correct choice!

For more information, please visit widia.com/novo.

1. Choose your application:

- Face Mills
- Shoulder Mills
- Helical Mills
- Slotting Mills
- Copy Mills

2. Identify material to be machined:

Each tool has a material grid marked with a letter indicating the materials that can be machined.

P	Steel
M	Stainless Steel
K	Cast Iron
N	Non-Ferrous
S	High-Temp Alloys
H	Hardened Materials

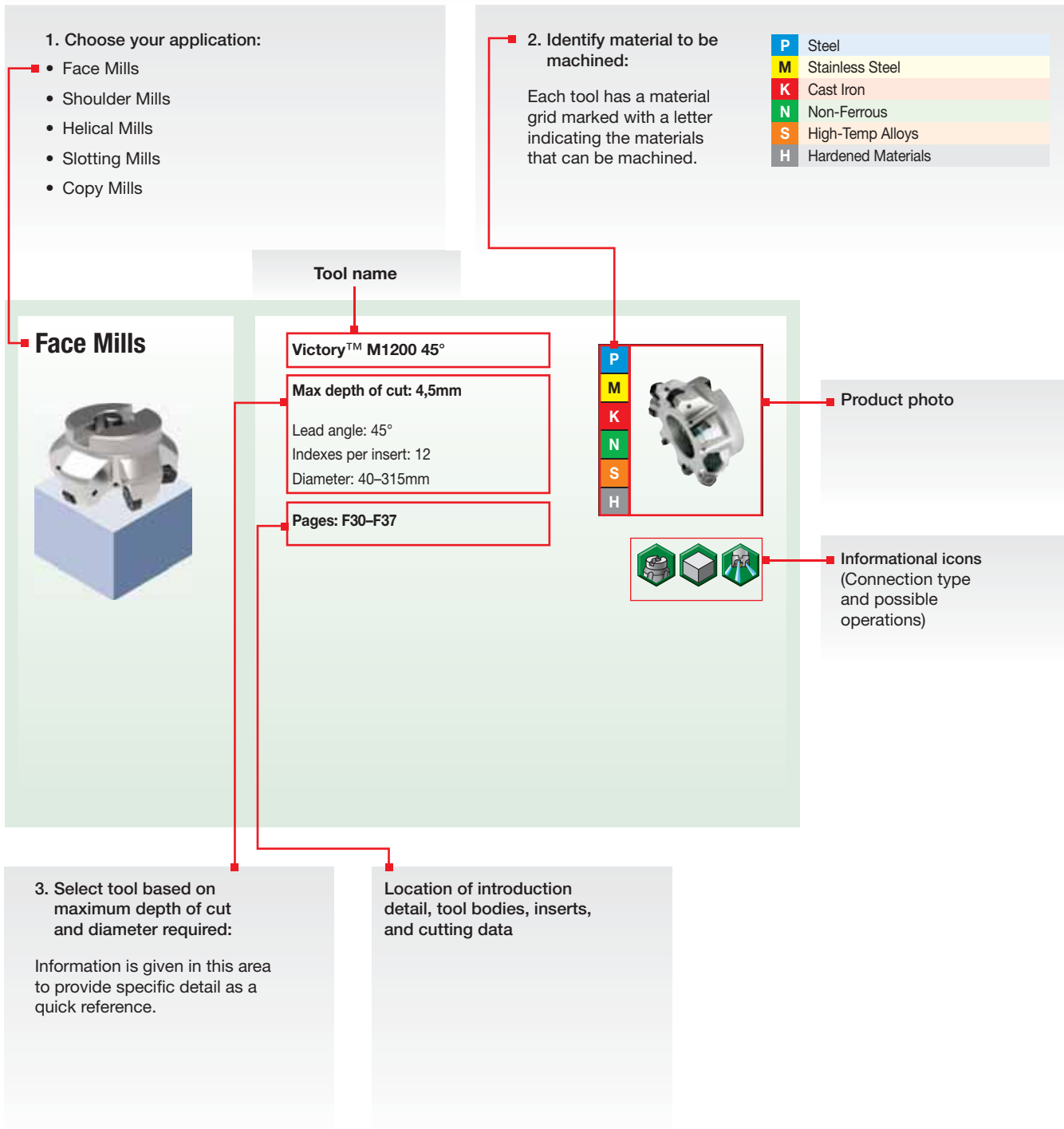

3. Select tool based on maximum depth of cut and diameter required:

Information is given in this area to provide specific detail as a quick reference.

Location of introduction detail, tool bodies, inserts, and cutting data

Selecting Tool Body, Insert, and Cutting Data

4. Choose the tool body:

Choose diameter (D1) and pitch (Z) of tool body.

NOTE: Make sure you select the correct shank style for your toolholder. For toolholders, visit widia.com.

Face Mills • Victory™ M1200 Series
Victory M1200 HF • Shell Mills

WIDIA

- Twelve cutting edges.
- High feed rates for rough face milling.
- Use standard M1200 inserts.

■ Shell Mills

order number	catalogue number	D1	D1 max	D	D6	L	Ap1 max	Z	max RPM	coolant supply	kg
3750370	M1200HF050Z04HN09	50	67,8	22	36	40	2,2	4	11400	Yes	0,65

5. Choose the inserts with the WIDIA™ insert selection guide:

- A Determine light machining, general purpose, or heavy machining according to workpiece material. See the Material Overview at the end of the catalogue for material descriptions.
- B Select the grade given in the insert selection guide. Use the six digit order number to easily place your order.

■ Insert Selection Guide

Material Group	Light Machining		General Purpose		Heavy Machining	
	Geometry	Grade	Geometry	Grade 5A	Geometry	Grade
P1-P2	.E...LD	WP40PM	.S..GD	WP40PM	.S..HD	WP40PM
P3-P4	.E...LD	WP25PM	.S..GD	WP35CM	.S..HD	WP35CM
P5-P6	.E...LD	WP25PM	.S..GD	WP35CM	.S..HD	WP35CM

● first choice

○ alternate choice

■ HNGJ-GD

catalogue number	cutting edges	D	L10	S	BS	Re	hm	TN6520	TN6525	TN6540	TN7535	WK15CM	WP25PM	WS30PM	WP35CM	WP40PM
HNGJ0905ANSNGD	12	16	8,58	5,56	1,80	1,20	0,10	3119541	3614650	3037586	3093721	5427370	5528974	5883349	5883350	5883350

6. Determine cutting data – with the WIDIA Recommended Speeds and Feeds tables:

- A Choose the recommended speed value according to the workpiece material and grade.
- B Choose the recommended starting feed rate according to the insert geometry and % of radial engagement ae.

Starting values are given in **bold**.

■ Recommended Starting Speeds [SFM]

Material Group		WP25PM		WP35CM		WS30PM		WP40PM 6A		TN6501	THM-U					
		1	2	1	2	1	2	1	2							
P	1	395	340	325	545	475	445	–	–	–	–					
	2	330	290	240	335	305	275	–	–	–	–					
	3	305	260	210	305	275	245	–	–	–	–					
	4	270	220	180	230	210	190	–	–	–	–					
	5	220	205	180	310	275	250	–	–	–	–					
	6	200	150	120	190	160	130	–	–	–	–					
M	1	245	215	200	245	220	185	270	240	220	235	205	185	–	–	–
	2	220	190	155	220	190	170	245	215	175	210	180	150	–	–	–
	3	170	145	115	175	155	140	185	160	125	155	140	110	–	–	–
K	1	275	245	220	355	320	290	–	–	–	–	–	–	–	–	–
	2	215	190	180	280	250	230	–	–	–	–	–	–	–	–	–
	3	180	160	145	235	210	190	–	–	–	–	–	–	–	–	–

■ Recommended Starting Feeds [mm]

Insert Geometry	Programmed Feed per Tooth (fz) as a % of Radial Depth of Cut (ae)												Insert Geometry			
	5%			10%			20% 6B			30%				40-100%		
.F.LDJ	0,17	0,32	0,65	0,13	0,23	0,47	0,09	0,17	0,35	0,08	0,15	0,31	0,08	0,14	0,28	.F.LDJ
.E..LD	0,17	0,50	1,00	0,13	0,36	0,72	0,09	0,27	0,54	0,08	0,23	0,47	0,08	0,21	0,43	.E..LD
.S..GD	0,33	0,84	1,35	0,24	0,60	0,97	0,18	0,45	0,72	0,16	0,39	0,63	0,14	0,36	0,57	.S..GD
.S..HD	0,33	0,84	1,35	0,24	0,60	0,97	0,18	0,45	0,72	0,16	0,39	0,63	0,14	0,36	0,57	.S..HD

NOTE: Use "Light Machining" value as starting feed rate.

Face Mills



Victory™ M1200 Mini HF 15°

Max depth of cut: 1,7mm

Lead angle: 15°
Indexes per insert: 12
Diameter: 25–80mm

Pages: F5–F11

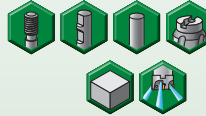

Victory™ M1200 Mini 45°

Max depth of cut: 3,5mm

Lead angle: 45°
Indexes per insert: 12
Diameter: 25–120mm

Pages: F12–F19

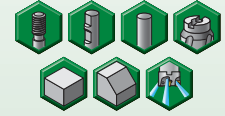
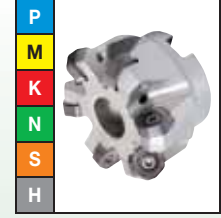

Victory™ M1200 Mini HD 59°

Max depth of cut: 4,7mm

Lead angle: 59°
Indexes per insert: 12
Diameter: 40–125mm

Pages: F20–F23

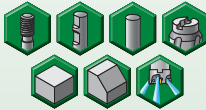

Victory™ M1200 HF 14.5°

Max depth of cut: 2,2mm

Lead angle: 14.5°
Indexes per insert: 12
Diameter: 50–160mm

Pages: F26–F29

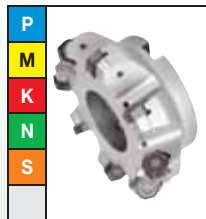

Victory™ M1200 45°

Max depth of cut: 4,5mm

Lead angle: 45°
Indexes per insert: 12
Diameter: 40–315mm

Pages: F30–F37

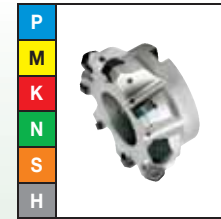

Victory™ M1200 HD 59°

Max depth of cut: 6mm

Lead angle: 59°
Indexes per insert: 12
Diameter: 50–160mm

Pages: F38–F41



(continued)

Face Mills

(continued)



M640

Max depth of cut: 4,8mm

Lead angle: 58°
Indexes per insert: 6
Diameter: 32–125mm

Pages: F44–F49

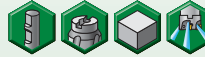

M660 SN1205..

Max depth of cut: 6,4mm

Lead angle: 45°
Indexes per insert: 4
Diameter: 20–160mm

Pages: F52–F57

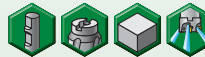

M660 SN1505..

Max depth of cut: 8,4mm

Lead angle: 45°
Indexes per insert: 4
Diameter: 100mm

Pages: F58–F60



90° Shoulder Mills



VSM11™

Max depth of cut: 11,7mm

Lead angle: 90°
Indexes per insert: 2
Diameter: 16–125mm

Pages: G4–G16

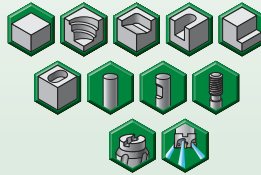
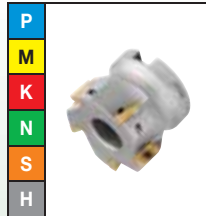

VSM490™-15

Max depth of cut: 15mm

Lead angle: 90°
Indexes per insert: 4
Diameter: 25–160mm

Pages: G32–G40

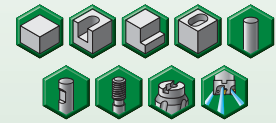
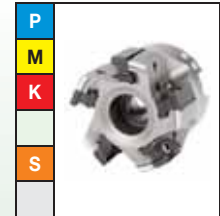

VSM17™

Max depth of cut: 16,33mm

Lead angle: 90°
Indexes per insert: 2
Diameter: 25–160mm

Pages: G20–G29

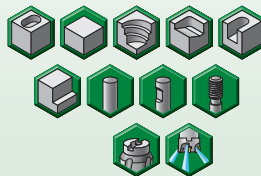

M690 SD1204..

Max depth of cut: 10mm

Lead angle: 90°
Indexes per insert: 4
Diameter: 50–160mm

Pages: G54–G57

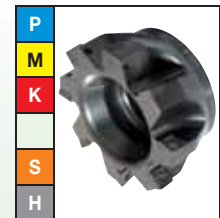

M690 SD1506..

Max depth of cut: 12mm

Lead angle: 90°
Indexes per insert: 4
Diameter: 50–125mm

Pages: G58–G61



M680

Max depth of cut: 14,0mm

Lead angle: 90°
Indexes per insert: 2
Diameter: 25mm–160mm

Pages: G44–G51

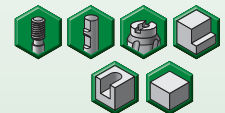
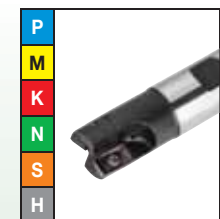

Helical Mills



M300

Max depth of cut: 112mm

Lead angle: 90°
Indexes per insert: 2
Diameter: 50–80mm

Pages: H4–H11



Slotting Mills



M95

**Slot Width Range:
4–10mm**

Indexes per insert: 4
Diameter: 100–200mm

Pages: I4–I7

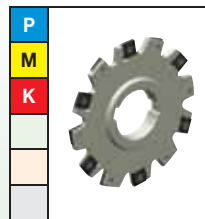

M900™

**Slot Width Range:
12–22mm**

Indexes per insert: 2
Diameter: 100–315mm

Pages: I10–I16, I18–I19

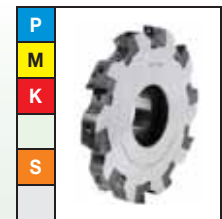

Copy Mills



M370™

Max depth of cut: up to 2mm

Indexes per insert: 6
Diameter: 25–125mm

Pages: J4–J16

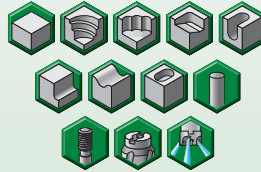
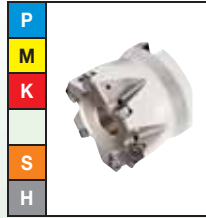

M200™

Max depth of cut: up to 5mm

Indexes per insert: up to 12
Diameter: 25–125mm

Pages: J20–J39

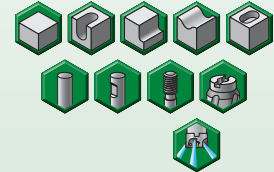
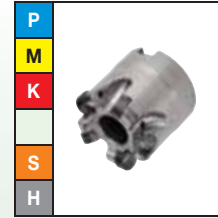

M100™

Max depth of cut: 6mm

Diameter: 24–125mm

Pages: J42–J67

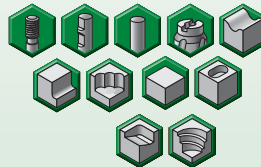

M270™ Ball Nose

Max depth of cut: 5–16mm

Diameter: 10–32mm

Pages: J70–J85

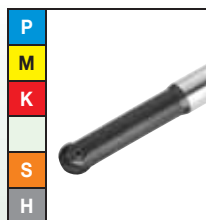

M270 Toroidal

Max depth of cut: 0,3–4mm

Diameter: 10–20mm

Pages: J86–J91

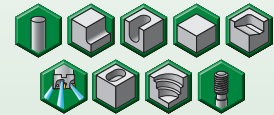
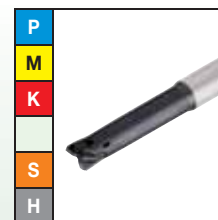

M270 High Feed

Max depth of cut:
0,6–1,1mm

Diameter: 10–20mm

Pages: J92–J98

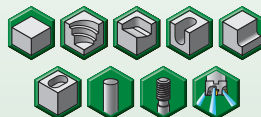
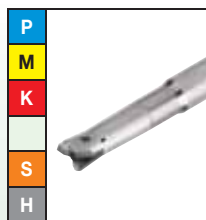

NOVO KNOWS SEARCH

Searching for a tool by using the outdated method of a catalogue has been replaced with the Advise and Select functions from NOVO™ — saving you time and money.

ADVISE

Uses a rules-based approach to provide cutting tool recommendations:

- Define Machining Feature (face milling, slotting, blind hole, etc.)
- Apply Constraint Requirements (geometric, material, tolerance, etc.)
- Set Machining Sequence (single or multi-step operations, rough then finish, etc.)
- Receive Ranked Results

SELECT

A method of selecting cutting tools from a tree structure via a hierarchy or parametric search:

- If you know which product you are looking for, a quick search can be performed by just the catalogue number or product description.
- Smart filters significantly reduce the amount of potential tooling solutions.
- After the tool is selected, NOVO also provides cutting and adaptive item options that fit with your solution.

NOVO can ensure you have the right tools on your machines, in the right sequence. Resulting in flawless execution that accelerates every job, and maximises every shift. widia.com/novo

How Do Catalogue Numbers Work?

Each character in our catalogue number signifies a specific trait of that product. Use the following key columns and corresponding images to easily identify which attributes apply.

Face Mills - Victory™ M1200 Mini Series Inserts

catalogue number: HNPJ0704ANSNGD

HNPJ0704ANSNGD

H		N		P		J				
Insert Shape		Insert Clearance Angle		Tolerance Class		Geometry and Clamping Type				
A		A				symbol	hole	shape of hole	chipbreaker	shape of insert's section
B		B				N	without		without	
C		C				R			single-sided	
E		D				F			double-sided	
H		E				A	with	cylindrical hole	without	
L		F				M			single-sided	
O		G				G			double-sided	
R		N				W	with	partly cylindrical hole, 40-60° countersink	without	
S		P				T			single-sided	
T						Q	with	partly cylindrical hole, 40-60° double countersink	without	
W						U			double-sided	
X	Special Design					B	with	partly cylindrical hole, 70-90° countersink	without	
						H			single-sided	
						C	with	partly cylindrical hole, 70-90° double countersink	without	
						J			double-sided	
						X	special design			

iC	tolerances on "iC"		tolerances on "M"	
	classes J, K, L, M, N (+/-)	class U (+/-)	classes M & N (+/-)	class U (+/-)
4,76-10,00	0,051	0,076	0,076	0,127
11,11-14,29	0,076	0,127	0,127	0,203
15,00-20,64	0,102	0,178	0,152	0,279
22,00-31,16	0,127	0,254	0,178	0,381
31,75-35,00	0,152	0,254	0,2	0,381

	iC (+/-)	M (+/-)	T (+/-)		iC (+/-)	M (+/-)	T (+/-)
A	0,025	0,005	0,025	J	0,05-0,15*	0,005	0,025
B	0,025	0,005	0,013	K	0,05-0,15*	0,013	0,025
C	0,025	0,013	0,025	L	0,05-0,15*	0,025	0,025
D	0,025	0,013	0,013	M	0,05-0,15*	0,08-0,20*	0,013
E	0,025	0,025	0,025	N	0,05-0,15*	0,08-0,20*	0,025
F	0,013	0,005	0,025	P**	0,038	0,038	0,038
G	0,025	0,025	0,013	U	0,08-0,25*	0,13-0,30*	0,013
H	0,013	0,013	0,025				

*See table above for tolerances according to insert size and class.
**WIDIA standard only.

By referencing this easy-to-use guide, you can identify the correct product to meet your needs.

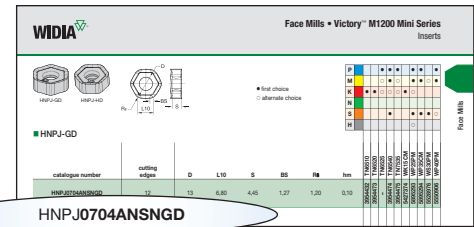

07
Size
(Cutting Edge Length)

04
Insert Thickness

symbol	thickness
T1	1,98
02	2,38
03	3,18
T3	3,97
04	4,76
05	5,56
06	6,35
07	7,94

AN
Corner Configuration

S
Cutting Edge Form

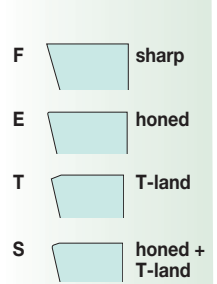

N
Insert Hand

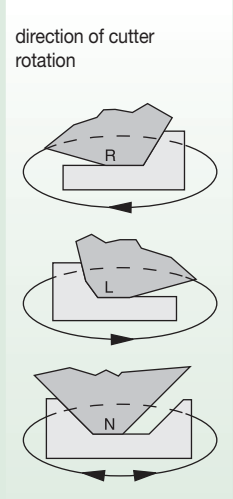

GD
Edge Geometry

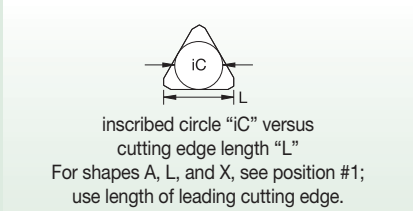

iC	"L" for shapes						
	S	T	R	O	C	H	E
6,00	-	-	06	-	-	-	-
6,35	06	11	06	02	06	03	06
8,00	-	-	08	-	-	-	-
9,52	09	16	09	04	09	05	09
10,00	-	-	10	-	-	-	-
12,00	-	-	12	-	-	-	-
12,70	12	22	12	05	12	07	13
15,88	15	27	15	06	16	09	16
16,00	-	-	16	-	-	-	-
19,05	19	33	19	07	19	11	19
20,00	-	-	20	-	-	-	-
25,00	-	-	25	-	-	-	-
25,40	25	4					

radius			
MO	round insert		
01	0,1mm	leading or major cutting edge facet or wiper edge assumed direction of feed motion lead angle K wiper edge clearance P	
02	0,2mm		
04	0,4mm		
05	0,5mm		
08	0,8mm		
10	1,0mm		
12	1,2mm		
15	1,5mm		
16	1,6mm		
24	2,4mm		
32	3,2mm		

How Do Catalogue Numbers Work?

Each character in our catalogue number signifies a specific trait of that product. Use the following key columns and corresponding images to easily identify which attributes apply.

- Twelve cutting edges.
- First choice for low depth-of-cut face milling.
- Maximum number of teeth per diameter.

■ Shell Mills

order number	catalogue number	D1	D1 max	D	D2	L	L2	Aq1 max	Z	max RPM	coolant supply	kg
3957995	M1200D100Z03C100HN07L800	42	45.7	72	38	40	40	3.5	4	15000	Yes	0.26
				42				3.5	5	15000	Yes	0.26
				42				3.5	4	15000	Yes	0.26

M1200D100Z03C100HN07L800

Indexable Milling Tool Bodies

M1200

Series

D

Cutting Diameter

100

Z

Number of Flutes

03

C

Shank Form

Z = Number of effective flutes

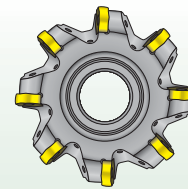

- C** = Cylindrical
- W** = Weldon®
- M** = Modular
- S** = Shell Mill

By referencing this easy-to-use guide, you can identify the correct product to meet your needs.

• Twelve cutting edges.
 • First choice for low depth-of-cut face milling.
 • Maximum number of teeth per diameter.

■ Shell Mills

order number	catalogue number	D1	D1 max	D2	D2 max	L	L2	Ag1 max	Z max	RPM	coolant	weight	kg
3857995	M1200D100Z03C100HN07L800	40	48.7	22	38	40	40	3.5	4	15000	Yes	0.26	
3857996	M1200D100Z03C100HN07L800	20	48.7	22	38	40	40	3.5	5	15000	Yes	0.26	

M1200D100Z03C100HN07L800

Indexable Milling Tool Bodies

100

Shank/Pilot Diameter

H

Insert Shape

N

Insert Clearance Angle

07

Insert Size (Cutting Edge Length)

L **800**

Overall Length of Tool
Used for all cylindrical shank and long version Weldon® if required (standard Weldon without)

A	M
B	O
C	P
D	R
E	S
H	T
K	V
L	W
	X Special Design

C
D
E
F
G
N
P

Optional uses as required

LH Left Hand

C Carbide Shank

HM Heavy Metal Shank

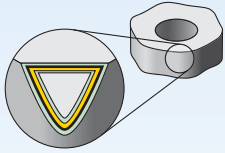

Modern coating technologies provide higher speed capabilities, greater productivity, and longer tool life.

Each insert has a material grid indicating primary and alternate uses for that tool, as well as whether it can be operated dry or with coolant.

P	Steel
M	Stainless Steel
K	Cast Iron
N	Non-Ferrous
S	High-Temp Alloys
H	Hardened Materials

primary use		alternate use	
▽▽▽	Light (finishing)	▽▽▽	Light (finishing)
▽▽	Medium	▽▽	Medium
▽	Heavy (roughing)	▽	Heavy (roughing)

Grade		P	M	K	N	S	H	dry	with coolant
TN2505		▽▽▽		▽▽▽			▽▽▽	•	
HC-H05 • PVD-TiAlN									
TN2510		▽▽		▽▽			▽▽	•	
HC-H10 • MT-CVD/CVD-TiN-TiCN-(ZrO ₂ -Al ₂ O ₃ -TiOx)									
TN2525		▽▽		▽▽			▽▽	•	
HC-H20 • PVD-TiAlN									
TN6501					▽▽▽			•	•
HC-N03 • PVD-TiB ₂									
TN6510				▽▽				•	
HC-K10 • PVD-TiAlN Nanolayer									
TN6520				▽▽				•	•
HC-K20 • PVD-TiAlN Nanolayer									

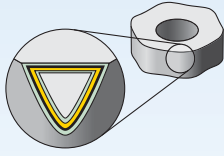

Modern coating technologies provide higher speed capabilities, greater productivity, and longer tool life.

Each insert has a material grid indicating primary and alternate uses for that tool, as well as whether it can be operated dry or with coolant.

P	Steel
M	Stainless Steel
K	Cast Iron
N	Non-Ferrous
S	High-Temp Alloys
H	Hardened Materials

primary use		alternate use	
▽▽▽	Light (finishing)	▽▽▽	Light (finishing)
▽▽	Medium	▽▽	Medium
▽	Heavy (roughing)	▽	Heavy (roughing)

Grade		P	M	K	N	S	H	dry	with coolant
TN6525		▽▽	▽▽	▽▽				•	
HC-P25 • PVD-TiAlN Nanolayer									
TN6540		▽	▽	▽		▽▽		•	•
HC-P40 • PVD-TiAlN Nanolayer									
TN7525		▽▽	▽▽					•	
HC-P25 • MT-CVD/CVD-TiN-TiCN-Al ₂ O ₃ -TiN									
TN7535		▽	▽	▽				•	
HC-P35 • MT-CVD/CVD-TiN-TiCN-Al ₂ O ₃									
TTI25		▽▽▽	▽▽▽					•	•
HT-P15 • Cermet									
THM				▽	▽	▽		•	•
HW-K15 • Uncoated									

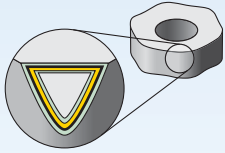

Modern coating technologies provide higher speed capabilities, greater productivity, and longer tool life.

Each insert has a material grid indicating primary and alternate uses for that tool, as well as whether it can be operated dry or with coolant.

P	Steel
M	Stainless Steel
K	Cast Iron
N	Non-Ferrous
S	High-Temp Alloys
H	Hardened Materials

primary use		alternate use	
▽▽▽	Light (finishing)	▽▽▽	Light (finishing)
▽▽	Medium	▽▽	Medium
▽	Heavy (roughing)	▽	Heavy (roughing)

Grade		P	M	K	N	S	H	dry	with coolant
THM-U					▽▽▽			•	•
HF-N05 • Uncoated									
TTM/TTM08		▽▽	▽▽	▽▽				•	•
HW-P25 • Uncoated									
WK15PM				▽▽				•	•
PVD-TiAlN Nanolayer									
WK15CM™				▽▽				•	
MT-CVD/TiN-TiCN-Al ₂ O ₃									
WP20CM		▽▽		▽▽					
MT-CVD/TiN-TiCN-Al ₂ O ₃									
WP25PM		▽▽	▽▽	▽▽		▽▽	▽▽	•	•
PVD-AlTiN Multilayer									

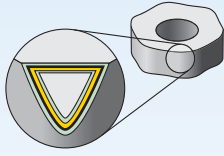

Modern coating technologies provide higher speed capabilities, greater productivity, and longer tool life.

Each insert has a material grid indicating primary and alternate uses for that tool, as well as whether it can be operated dry or with coolant.

P	Steel
M	Stainless Steel
K	Cast Iron
N	Non-Ferrous
S	High-Temp Alloys
H	Hardened Materials

primary use		alternate use	
▽▽▽	Light (finishing)	▽▽▽	Light (finishing)
▽▽	Medium	▽▽	Medium
▽	Heavy (roughing)	▽	Heavy (roughing)

Grade		P	M	K	N	S	H	dry	with coolant
WS30PM™		▽▽	▽▽			▽▽		•	•
PVD-AITiN Multilayer									
WU35PM		▽	▽			▽		•	•
PVD-AITiN Multilayer									
WP35CM		▽	▽	▽				•	
MT-CVD/TiN-TiCN-Al ₂ O ₃									
WP40PM™		▽	▽			▽		•	•
PVD TiAlN-AlCrN Multilayer									
WK25YM				▽▽				•	
Silicon Nitride									
WDN00U™					▽▽▽ ▽▽▽ ▽				•
Ultra-fine grain PCD									



Indexable Milling • Face Mills

M1200 Mini • First Choice for Taper 40 Spindle Machines	F2–F23
M1200 • First Choice for Taper 50 Spindle Machines.....	F24–F41
M640 • High Positive Geometries for Low Power Machines	F42–F49
M660 • Heavy-Duty Applications	F50–F60



One Series Meets Every Face Milling Need •

WIDIA™ Victory™ M1200 Mini

For consistent performance, look no further than the WIDIA Victory™ M1200 Mini. This easy-to-use product ensures great tool life, reduced machining time, and maximum productivity.



M1200 Mini





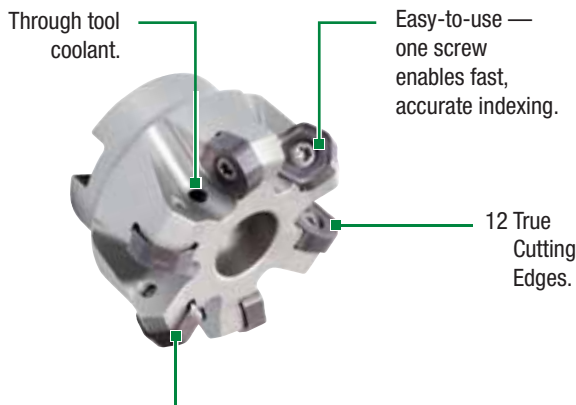



- Low cost per edge and high productivity.
- Reduced cutting forces due to soft cutting action.
- Significantly increased Metal Removal Rates (MRR).
- Victory™ M1200 Mini available in 15°, 45°, and 59° lead.
- WIDIA premium milling grades.
- Excellent tool life in light to heavy machining.
- Shorter machining cycle times.

Best-in-class face milling platform to boost productivity on taper 40 spindle milling machines and driven tools.



Comprehensive standard offering for coarse, medium, and fine pitch cutter bodies to match all shop floor needs.

Latest soft cutting edge insert design for all material groups

<p>-FNLDJ</p> 	<p>-ENLD</p> 
	
<p>Machining Aluminium</p>	<p>Light Machining</p>
<p>-SNGD</p> 	<p>-SNHD</p> 
	
<p>General Purpose</p>	<p>Heavy Machining</p>

Face Mills



Victory™ M1200 Mini HF 15°

Max depth of cut: 1,7mm

Lead angle: 15°
Indexes per insert: 12
Diameter: 25–80mm

Pages: F5–F11

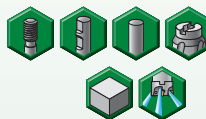
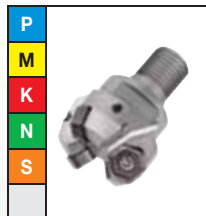

Victory™ M1200 Mini 45°

Max depth of cut: 3,5mm

Lead angle: 45°
Indexes per insert: 12
Diameter: 25–120mm

Pages: F12–F19

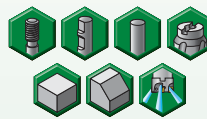
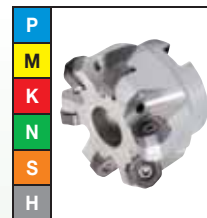

Victory™ M1200 Mini HD 59°

Max depth of cut: 4,7mm

Lead angle: 59°
Indexes per insert: 12
Diameter: 40–125mm

Pages: F20–F23

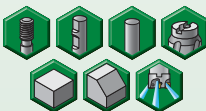

■ **Easy-to-use wiper insert setup to achieve excellent surface floor finish**

Wiper insert overlapping vs. regular insert

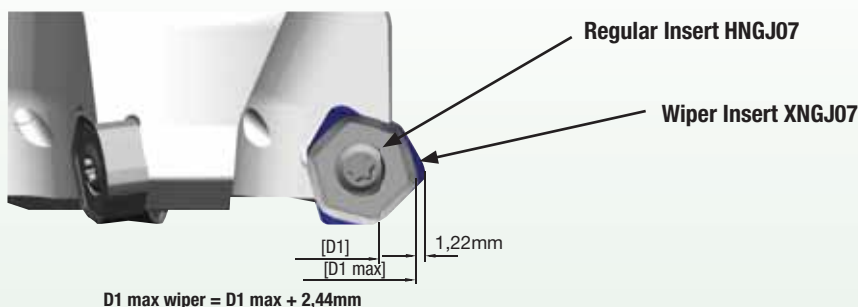

- Wiper inserts only applied with 45° lead angle cutter bodies.
- Easy to use. Regular and wiper inserts are loaded into fixed pockets. No adjustment required.
- Please have D1 max wiper in mind in case of limited working area.
- Use wiper inserts only in combination with periphery ground regular inserts HNGJ07.
- Up to cutting diameter D1=100mm load one wiper insert.
- For cutting diameter D1=125mm and above load two wiper inserts.
- Each wiper insert XNGJ07 can be applied with three right hand R and three left hand L cutting edges.

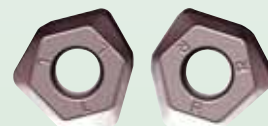

Victory™ M1200 Mini Series
Victory™ M1200 Mini HF High-Feed 15°

12 True
Cutting
Edges

Insert HNGJ0704
HNPJ0704

Ap1 max = 1,7mm

M1200 Mini HF can be loaded with all M1200 Mini standard inserts, except wiper inserts.

Victory™ M1200 Mini HF High-Feed

First choice for long reach face milling applications or light fixtures.

Chip thinning effect due to lead angle 15°. Tremendous enlargement of feed rate and MRR.

Up to 40% shorter machining cycle time.

Victory™ M1200 Mini 45°

12 True
Cutting
Edges

Insert HNGJ0704
HNPJ0704

Ap1 max = 3,5mm

Best-in-class leader in face milling up to Ap1 max = 3,5mm. Excellent choice for near net shape strategies and driven tools.

Victory™ M1200 Mini HD 59°



12 True
Cutting
Edges

Insert HNGJ0704
HNPJ0704

Ap1 max = 4,7mm

Achieve a higher axial depth-of-cut capability up to Ap1 = 4,7mm with standard M1200 Mini inserts.

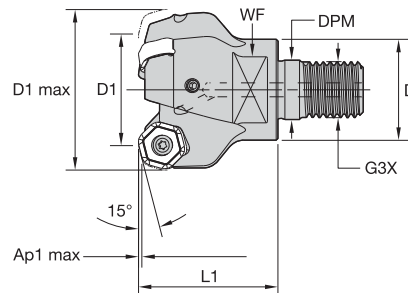
- Twelve cutting edges.
- First choice for low depth-of-cut face milling.
- High-feed capability.



Face Mills

■ Screw-On End Mills

order number	catalogue number	D1	D1 max	D	DPM	G3X	L1	WF	Ap1 max	Z	max RPM	coolant supply	kg
4136874	M1200HF025Z02M16HN07	25	39	29	17,0	M16	32	22	1,7	2	20000	Yes	0,2
4136875	M1200HF025Z03M16HN07	25	39	29	17,0	M16	32	22	1,7	3	20000	Yes	0,2
4136876	M1200HF032Z03M16HN07	32	46	29	17,0	M16	40	22	1,7	3	17600	Yes	0,3
4136877	M1200HF032Z04M16HN07	32	46	29	17,0	M16	40	22	1,7	4	17600	Yes	0,3
4136878	M1200HF040Z04M16HN07	40	54	29	17,0	M16	40	22	1,7	4	15800	Yes	0,3
4136879	M1200HF040Z05M16HN07	40	54	29	17,0	M16	40	22	1,7	5	15800	Yes	0,3

■ Spare Parts



insert screw



Nm



Torx wrench

D1	insert screw	Nm	Torx wrench
25	12146034500	3,5	12148082400
32	12146034500	3,5	12148082400
40	12146034500	3,5	12148082400

- Twelve cutting edges.
- First choice for low depth-of-cut face milling.
- High-feed capability.

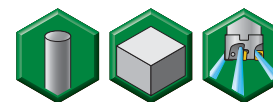

Face Mills

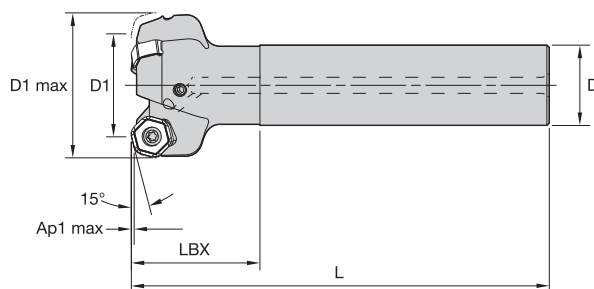

■ Cylindrical Shanks

order number	catalogue number	D1	D1 max	D	L	LBX	Ap1 max	Z	max RPM	coolant supply	kg
4136880	M1200HF025Z02A20HN07L120	25	39,1	20	120	32	1,7	2	20000	Yes	0,33
4136881	M1200HF025Z03A20HN07L120	25	39,1	20	120	32	1,7	3	20000	Yes	0,31
4136882	M1200HF032Z03A25HN07L130	32	46,1	25	130	40	1,7	3	17600	Yes	0,52
4136883	M1200HF032Z04A25HN07L130	32	46,1	25	130	40	1,7	4	17600	Yes	0,53

■ Spare Parts



D1	insert screw	Nm	Torx driver
25	12146034500	3,5	12148082400
32	12146034500	3,5	12148082400

- Twelve cutting edges.
- First choice for low depth-of-cut face milling.
- High-feed capability.

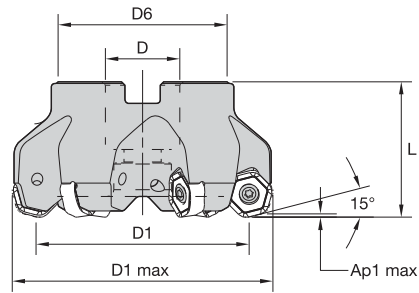

Face Mills

■ Shell Mills

order number	catalogue number	D1	D1 max	D	D6	L	Ap1 max	Z	max RPM	coolant supply	kg
4136884	M1200HF040Z05HN07	40	54,1	22	38	40	1,7	5	15800	Yes	0,29
4136885	M1200HF050Z05HN07	50	64,1	22	38	40	1,7	5	12700	Yes	0,40
4136886	M1200HF063Z06HN07	63	77,1	22	50	40	1,7	6	10100	Yes	0,67
4136887	M1200HF080Z08HN07	80	94,1	27	60	50	1,7	8	7900	Yes	1,26

■ Spare Parts



D1	insert screw	Nm	Torx driver	socket-head cap screw
40	12146034500	3,5	12148082400	12146120500
50	12146034500	3,5	12148082400	12146120500
63	12146034500	3,5	12148082400	12146120500
80	12146034500	3,5	12148082400	12748701000

■ Insert Selection Guide

Material Group	Light Machining		General Purpose		Heavy Machining	
	Geometry	Grade	Geometry	Grade	Geometry	Grade
P1-P2	.E..LD	WP40PM	.S..GD	WP40PM	.S..HD	WP40PM
P3-P4	.E..LD	WP25PM	.S..GD	WP35CM	.S..HD	WP35CM
P5-P6	.E..LD	WP25PM	.S..GD	WP35CM	.S..HD	WP35CM
M1-M2	.E..LD	WP25PM	.S..GD	WP25PM	.S..HD	WP25PM
M3	.E..LD	WP35CM	.S..GD	WP35CM	.S..HD	WP35CM
K1-K2	.E..LD	TN6510	.S..GD	WK15CM	.S..HD	WK15CM
K3	.E..LD	WP35CM	.S..GD	WP35CM	.S..HD	WP35CM
N1-N2	.F..LDJ	TN6501	.F..LDJ	TN6501	.F..LDJ	TN6501
N3	.F..LDJ	TN6501	.F..LDJ	TN6501	.F..LDJ	TN6501
S1-S2	.E..LD	WS30PM	.S..GD	WS30PM	.S..HD	WP25PM
S3	.E..LD	WS30PM	.S..GD	WS30PM	.S..GD	WS30PM
S4	.E..LD	WS30PM	.S..GD	WS30PM	.S..HD	WP40PM
H1	-	-	-	-	-	-

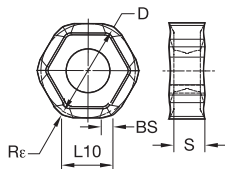
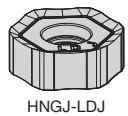

● first choice
○ alternate choice

P	●		
M	●		
K	●		
N	●	●	●
S	●		
H			

■ HNGJ-LDJ

catalogue number	cutting edges	D	L10	S	BS	Rε	hm	TN6501	THM-U
HNGJ0704ANFNLDJ	12	13	6,80	4,48	1,60	1,20	0,08	3954414	3954332

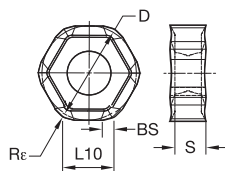
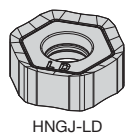

● first choice
○ alternate choice

P	●		●	●	●	●	●	●	●
M	●		○	●	○	●	●	○	●
K	●	●	○	○	○	●	○		
N	●								
S	●			●		●	●	○	
H							○		

■ HNGJ-LD

catalogue number	cutting edges	D	L10	S	BS	Rε	hm	TN6510	TN6520	TN6525	TN6540	TN7535	WK15CM	WP25PM	WP35CM	WS30PM	WP40PM
HNGJ0704ANENLD	12	13	6,80	4,48	1,60	1,20	0,08	3954419	3954420	3954421	3954422	3954423	5895291	5895292	5528975	5550905	
HNGJ070432ANENLD	12	13	6,80	4,48	-	3,20	0,08	3954428									

■ Recommended Starting Speeds [m/min]

Face Mills

Material Group		TN6510			TN6520			TN6525			TN6540			TN7535			WK15CM		
P	1	-	-	-	-	-	-	410	320	280	360	280	240	545	475	445	-	-	-
	2	-	-	-	-	-	-	320	250	215	250	190	170	335	305	275	-	-	-
	3	-	-	-	-	-	-	280	215	185	215	170	140	305	275	245	-	-	-
	4	-	-	-	-	-	-	235	170	145	180	130	110	230	210	190	-	-	-
	5	-	-	-	-	-	-	310	235	200	240	180	150	310	275	250	-	-	-
	6	-	-	-	-	-	-	205	160	130	160	120	100	190	160	130	-	-	-
M	1	-	-	-	-	-	-	190	120	80	130	80	60	245	220	185	-	-	-
	2	-	-	-	-	-	-	120	80	50	80	50	40	220	190	170	-	-	-
	3	-	-	-	-	-	-	125	80	55	85	50	40	175	155	140	-	-	-
K	1	480	350	260	450	320	230	275	245	220	220	205	180	355	320	290	505	460	410
	2	420	280	205	390	250	190	215	190	180	175	155	140	280	250	230	400	355	330
	3	335	260	200	300	230	160	180	160	145	155	145	125	235	210	190	335	300	275
N	1	-	-	-	-	-	-	-	-	-	-	-	-	-	-	-	-	-	-
	2	-	-	-	-	-	-	-	-	-	-	-	-	-	-	-	-	-	-
	3	-	-	-	-	-	-	-	-	-	-	-	-	-	-	-	-	-	-
S	1	-	-	-	-	-	-	-	-	-	50	35	30	-	-	-	-	-	-
	2	-	-	-	-	-	-	-	-	-	25	20	10	-	-	-	-	-	-
	3	-	-	-	-	-	-	-	-	-	70	40	30	-	-	-	-	-	-
	4	-	-	-	-	-	-	-	-	-	60	30	25	-	-	-	-	-	-
H	1	-	-	-	-	-	-	-	-	-	-	-	-	-	-	-	-	-	-
	2	-	-	-	-	-	-	-	-	-	-	-	-	-	-	-	-	-	-
	3	-	-	-	-	-	-	-	-	-	-	-	-	-	-	-	-	-	-

(continued)

(Recommended Starting Speeds [m/min] – continued)

Material Group		WP25PM			WP35CM			WS30PM			WP40PM			TN6501			THM-U		
P	1	395	340	325	545	475	445	-	-	-	355	310	295	-	-	-	-	-	-
	2	330	290	240	335	305	275	-	-	-	300	260	215	-	-	-	-	-	-
	3	305	260	210	305	275	245	-	-	-	275	235	190	-	-	-	-	-	-
	4	270	220	180	230	210	190	-	-	-	245	205	160	-	-	-	-	-	-
	5	220	205	180	310	275	250	-	-	-	205	185	160	-	-	-	-	-	-
	6	200	150	120	190	160	130	-	-	-	180	140	110	-	-	-	-	-	-
M	1	245	215	200	245	220	185	270	240	220	235	205	185	-	-	-	-	-	-
	2	220	190	155	220	190	170	245	215	175	210	180	150	-	-	-	-	-	-
	3	170	145	115	175	155	140	185	160	125	155	140	110	-	-	-	-	-	-
K	1	275	245	220	355	320	290	-	-	-	-	-	-	-	-	-	-	-	-
	2	215	190	180	280	250	230	-	-	-	-	-	-	-	-	-	-	-	-
	3	180	160	145	235	210	190	-	-	-	-	-	-	-	-	-	-	-	-
N	1	-	-	-	-	-	-	-	-	-	-	-	-	2400	1440	1200	2400	1440	1200
	2	-	-	-	-	-	-	-	-	-	-	-	-	1640	980	800	1640	980	800
	3	-	-	-	-	-	-	-	-	-	-	-	-	960	600	480	960	600	480
S	1	50	40	30	-	-	-	55	50	35	50	40	35	-	-	-	-	-	-
	2	50	40	30	-	-	-	55	50	35	50	40	35	-	-	-	-	-	-
	3	60	50	30	-	-	-	65	55	35	60	50	35	-	-	-	-	-	-
	4	85	60	40	80	60	40	100	70	50	80	60	40	-	-	-	-	-	-
H	1	145	110	85	-	-	-	-	-	-	-	-	-	-	-	-	-	-	-
	2	-	-	-	-	-	-	-	-	-	-	-	-	-	-	-	-	-	-
	3	-	-	-	-	-	-	-	-	-	-	-	-	-	-	-	-	-	-

NOTE: FIRST choice starting speeds are in **bold** type.
As the average chip thickness increases, the speed should be decreased.

Recommended Starting Feeds

■ Recommended Starting Feeds [mm]

Light Machining	General Purpose	Heavy Machining
-----------------	-----------------	-----------------

Insert Geometry	Programmed Feed per Tooth (fz) as a % of Radial Depth of Cut (ae)															Insert Geometry
	5%			10%			20%			30%			40-100%			
.F.LDJ	0,48	0,89	1,81	0,34	0,64	1,29	0,26	0,48	0,96	0,22	0,42	0,83	0,21	0,38	0,76	.F.LDJ
.E..LD	0,48	1,38	2,85	0,34	0,99	2,00	0,26	0,74	1,48	0,22	0,64	1,28	0,21	0,59	1,17	.E..LD
.S..GD	0,92	2,35	3,89	0,66	1,67	2,70	0,49	1,23	1,98	0,43	1,07	1,72	0,39	0,98	1,57	.S..GD
.S..HD	0,92	2,35	3,89	0,66	1,67	2,70	0,49	1,23	1,98	0,43	1,07	1,72	0,39	0,98	1,57	.S..HD

NOTE: Use "Light Machining" value as starting feed rate.

- Twelve cutting edges.
- First choice for low depth-of-cut face milling.
- Maximum number of teeth per diameter.

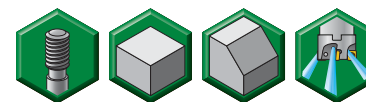

Face Mills

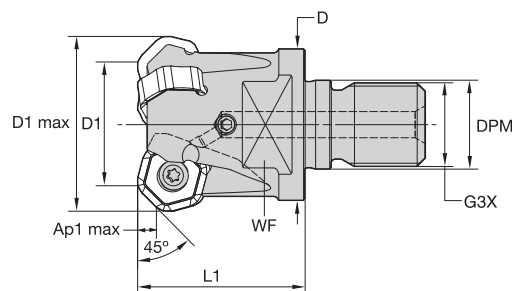

■ Screw-On End Mills

order number	catalogue number	D1	D1 max	D	DPM	G3X	L1	WF	Ap1 max	Z	max RPM	coolant supply	kg
3957839	M1200D025Z02M16HN07	25	33,7	29	17,0	M16	32	22	3,5	2	20000	Yes	0,13
3957840	M1200D025Z03M16HN07	25	33,7	29	17,0	M16	32	22	3,5	3	20000	Yes	0,13
3957841	M1200D032Z03M16HN07	32	40,7	29	17,0	M16	40	22	3,5	3	17600	Yes	0,20
3957842	M1200D032Z04M16HN07	32	40,7	29	17,0	M16	40	22	3,5	4	17600	Yes	0,20
3957963	M1200D040Z04M16HN07	40	48,7	29	17,0	M16	40	22	3,5	4	15800	Yes	0,24
3957964	M1200D040Z05M16HN07	40	48,7	29	17,0	M16	40	22	3,5	5	15800	Yes	0,25

■ Spare Parts



D1	insert screw	Nm	Torx driver
25	12146034500	3,5	12148082400
32	12146034500	3,5	12148082400
40	12146034500	3,5	12148082400

- Twelve cutting edges.
- First choice for low depth-of-cut face milling.
- Maximum number of teeth per diameter.

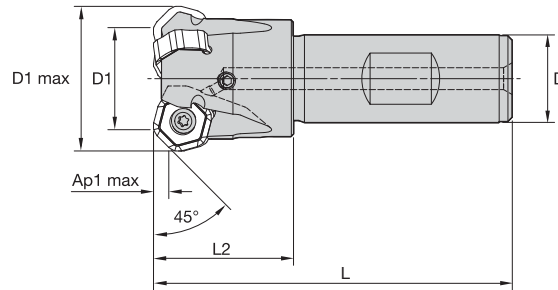
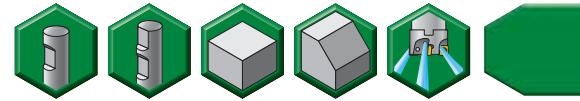

Face Mills

■ **Weldon Shanks**

order number	catalogue number	D1	D1 max	D	L	L2	Ap1 max	Z	max RPM	coolant supply	kg
3958011	M1200D025Z02B20HN07	25	33,7	20	82	32	3,5	2	20000	Yes	0,22
3958012	M1200D025Z03B20HN07	25	33,7	20	82	32	3,5	3	20000	Yes	0,21
3958023	M1200D032Z03B25HN07	32	40,7	25	97	40	3,5	3	17600	Yes	0,39
3958024	M1200D032Z04B25HN07	32	40,7	25	97	40	3,5	4	17600	Yes	0,40

■ **Spare Parts**



D1	insert screw	Nm	Torx driver
25	12146034500	3,5	12148082400
32	12146034500	3,5	12148082400

- Twelve cutting edges.
- First choice for low depth-of-cut face milling.
- Maximum number of teeth per diameter.

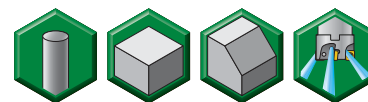

Face Mills

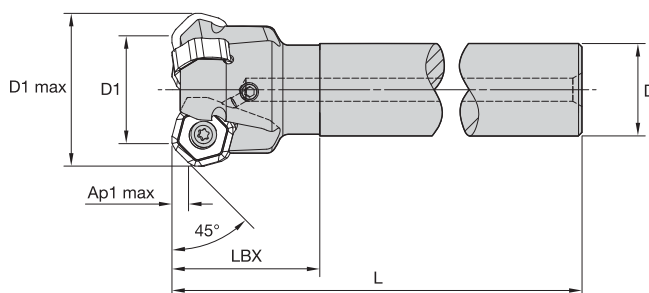

■ Cylindrical Shanks

order number	catalogue number	D1	D1 max	D	L	LBX	Ap1 max	Z	max RPM	coolant supply	kg
3958025	M1200D025Z02A20HN07L120	25	33,7	20	120	32	3,5	2	20000	Yes	0,29
3958026	M1200D025Z03A20HN07L120	25	33,7	20	120	32	3,5	3	20000	Yes	0,28
3958029	M1200D025Z02A25HN07L200	25	33,7	25	200	32	3,5	2	20000	Yes	0,72
3958030	M1200D025Z03A25HN07L200	25	33,7	25	200	32	3,5	3	20000	Yes	0,71
3958027	M1200D032Z03A25HN07L130	32	40,7	25	130	40	3,5	3	17600	Yes	0,49
3958028	M1200D032Z04A25HN07L130	32	40,7	25	130	40	3,5	4	17600	Yes	0,50

■ Spare Parts



insert
screw



Nm



Torx
driver

D1	insert screw	Nm	Torx driver
25	12146034500	3,5	12148082400
32	12146034500	3,5	12148082400

- Twelve cutting edges.
- First choice for low depth-of-cut face milling.
- Maximum number of teeth per diameter.

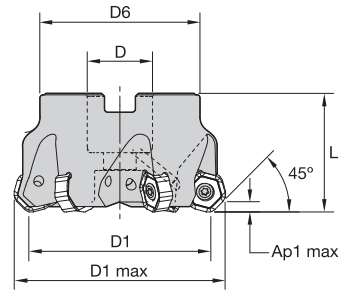

Face Mills

■ Shell Mills

order number	catalogue number	D1	D1 max	D	D6	L	L2	Ap1 max	Z	max RPM	coolant supply	kg
3957995	M1200D040Z04HN07	40	48,7	22	38	40	40	3,5	4	15800	Yes	0,26
3957996	M1200D040Z05HN07	40	48,7	22	38	40	40	3,5	5	15800	Yes	0,26
3957997	M1200D050Z04HN07	50	58,7	22	38	40	40	3,5	4	12700	Yes	0,35
3957998	M1200D050Z05HN07	50	58,7	22	38	40	40	3,5	5	12700	Yes	0,36
3957999	M1200D050Z06HN07	50	58,7	22	38	40	40	3,5	6	12700	Yes	0,35
3958000	M1200D063Z04HN07	63	71,7	22	50	40	40	3,5	4	10100	Yes	0,58
3958001	M1200D063Z06HN07	63	71,7	22	50	40	40	3,5	6	10100	Yes	0,65
3958002	M1200D063Z08HN07	63	71,7	22	50	40	40	3,5	8	10100	Yes	0,62
3958003	M1200D080Z05HN07	80	88,7	27	60	50	50	3,5	5	7900	Yes	1,11
3958004	M1200D080Z08HN07	80	88,7	27	60	50	50	3,5	8	7900	Yes	1,24
3958005	M1200D080Z10HN07	80	88,7	27	60	50	50	3,5	10	7900	Yes	1,17
3958006	M1200D100Z06HN07	100	108,7	32	80	50	50	3,5	6	6300	Yes	1,71
3958007	M1200D100Z09HN07	100	108,7	32	80	50	50	3,5	9	6300	Yes	1,82
3958008	M1200D100Z12HN07	100	108,7	32	80	50	50	3,5	12	6300	Yes	1,82
4138470	M1200D125Z08HN07	125	133,7	40	90	63	—	3,5	8	5050	Yes	2,84
4138471	M1200D125Z12HN07	125	133,7	40	90	63	—	3,5	12	5050	Yes	2,96
4138472	M1200D125Z16HN07	125	133,7	40	90	63	—	3,5	16	5050	Yes	3,02

■ Spare Parts



D1	insert screw	Nm	Torx driver	socket-head cap screw	mounting screw with coolant grooves	coolant screw assembly	coolant lock screw	coolant cap
40	12146034500	3,5	12148082400	—	12146109200	—	—	—
50	12146034500	3,5	12148082400	12146120500	—	—	—	—
63	12146034500	3,5	12148082400	12146120500	—	—	—	—
80	12146034500	3,5	12148082400	12748701000	—	—	—	—
100	12146034500	3,5	12148082400	—	—	12146109400	—	—
125	12146034500	3,5	12148082400	—	—	—	12146107000	12146111000

NOTE: Mounting screw with coolant groove, coolant screw assembly, coolant lock screw, and coolant cap must be ordered separately.

■ Insert Selection Guide

Material Group	Light Machining		General Purpose		Heavy Machining	
	Geometry	Grade	Geometry	Grade	Geometry	Grade
P1-P2	.E..LD	WP40PM	.S..GD	WP40PM	.S..HD	WP40PM
P3-P4	.E..LD	WP25PM	.S..GD	WP35CM	.S..HD	WP35CM
P5-P6	.E..LD	WP25PM	.S..GD	WP35CM	.S..HD	WP35CM
M1-M2	.E..LD	WP25PM	.S..GD	WP25PM	.S..HD	WP25PM
M3	.E..LD	WP35CM	.S..GD	WP35CM	.S..HD	WP35CM
K1-K2	.E..LD	TN6510	.S..GD	WK15CM	.S..HD	WK15CM
K3	.E..LD	WP35CM	.S..GD	WP35CM	.S..HD	WP35CM
N1-N2	.F..LDJ	TN6501	.F..LDJ	TN6501	.F..LDJ	TN6501
N3	.F..LDJ	TN6501	.F..LDJ	TN6501	.F..LDJ	TN6501
S1-S2	.E..LD	WS30PM	.S..GD	WS30PM	.S..HD	WP25PM
S3	.E..LD	WS30PM	.S..GD	WS30PM	.S..GD	WS30PM
S4	.E..LD	WS30PM	.S..GD	WS30PM	.S..HD	WP40PM
H1	-	-	-	-	-	-

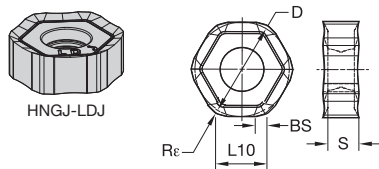

● first choice
○ alternate choice

P	●		
M	●		
K	●		
N	●	●	●
S	●		
H	●		

■ HNGJ-LDJ

catalogue number	cutting edges	D	L10	S	BS	Rε	hm	TN6501	THM-U
HNGJ0704ANFNLDJ	12	13	6,80	4,48	1,60	1,20	0,08	3954414	3954332

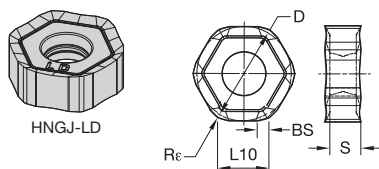

● first choice
○ alternate choice

P	●		●	●	●	●	●	●	●
M	●		○	●	○	●	●	○	●
K	●	●	○	○	○	●	○		
N	●								
S	●			●		●	●	○	
H	●						○		

■ HNGJ-LD

catalogue number	cutting edges	D	L10	S	BS	Rε	hm	TN6510	TN6520	TN6525	TN6540	TN7535	WK15CM	WP25PM	WP35CM	WS30PM	WP40PM
HNGJ0704ANENLD	12	13	6,80	4,48	1,60	1,20	0,08	3954419	3954420	3954421	3954422	—	—	5895291	5895292	5528975	5550905
HNGJ070432ANENLD	12	13	6,80	4,48	—	3,20	0,08	3954428	—	—	—	—	—	—	—	—	—

■ Recommended Starting Speeds [m/min]

Face Mills

Material Group		TN6510			TN6520			TN6525			TN6540			TN7535			WK15CM		
P	1	-	-	-	-	-	-	410	320	280	360	280	240	545	475	445	-	-	-
	2	-	-	-	-	-	-	320	250	215	250	190	170	335	305	275	-	-	-
	3	-	-	-	-	-	-	280	215	185	215	170	140	305	275	245	-	-	-
	4	-	-	-	-	-	-	235	170	145	180	130	110	230	210	190	-	-	-
	5	-	-	-	-	-	-	310	235	200	240	180	150	310	275	250	-	-	-
	6	-	-	-	-	-	-	205	160	130	160	120	100	190	160	130	-	-	-
M	1	-	-	-	-	-	-	190	120	80	130	80	60	245	220	185	-	-	-
	2	-	-	-	-	-	-	120	80	50	80	50	40	220	190	170	-	-	-
	3	-	-	-	-	-	-	125	80	55	85	50	40	175	155	140	-	-	-
K	1	480	350	260	450	320	230	275	245	220	220	205	180	355	320	290	505	460	410
	2	420	280	205	390	250	190	215	190	180	175	155	140	280	250	230	400	355	330
	3	335	260	200	300	230	160	180	160	145	155	145	125	235	210	190	335	300	275
N	1	-	-	-	-	-	-	-	-	-	-	-	-	-	-	-	-	-	-
	2	-	-	-	-	-	-	-	-	-	-	-	-	-	-	-	-	-	-
	3	-	-	-	-	-	-	-	-	-	-	-	-	-	-	-	-	-	-
S	1	-	-	-	-	-	-	-	-	-	50	35	30	-	-	-	-	-	-
	2	-	-	-	-	-	-	-	-	-	25	20	10	-	-	-	-	-	-
	3	-	-	-	-	-	-	-	-	-	70	40	30	-	-	-	-	-	-
	4	-	-	-	-	-	-	-	-	-	60	30	25	-	-	-	-	-	-
H	1	-	-	-	-	-	-	-	-	-	-	-	-	-	-	-	-	-	-
	2	-	-	-	-	-	-	-	-	-	-	-	-	-	-	-	-	-	-
	3	-	-	-	-	-	-	-	-	-	-	-	-	-	-	-	-	-	-

(continued)

(Recommended Starting Speeds [m/min] – continued)

Material Group		WP25PM			WP35CM			WS30PM			WP40PM			TN6501			THM-U		
P	1	395	340	325	545	475	445	-	-	-	355	310	295	-	-	-	-	-	-
	2	330	290	240	335	305	275	-	-	-	300	260	215	-	-	-	-	-	-
	3	305	260	210	305	275	245	-	-	-	275	235	190	-	-	-	-	-	-
	4	270	220	180	230	210	190	-	-	-	245	205	160	-	-	-	-	-	-
	5	220	205	180	310	275	250	-	-	-	205	185	160	-	-	-	-	-	-
	6	200	150	120	190	160	130	-	-	-	180	140	110	-	-	-	-	-	-
M	1	245	215	200	245	220	185	270	240	220	235	205	185	-	-	-	-	-	-
	2	220	190	155	220	190	170	245	215	175	210	180	150	-	-	-	-	-	-
	3	170	145	115	175	155	140	185	160	125	155	140	110	-	-	-	-	-	-
K	1	275	245	220	355	320	290	-	-	-	-	-	-	-	-	-	-	-	-
	2	215	190	180	280	250	230	-	-	-	-	-	-	-	-	-	-	-	-
	3	180	160	145	235	210	190	-	-	-	-	-	-	-	-	-	-	-	-
N	1	-	-	-	-	-	-	-	-	-	-	-	-	2400	1440	1200	2400	1440	1200
	2	-	-	-	-	-	-	-	-	-	-	-	-	1640	980	800	1640	980	800
	3	-	-	-	-	-	-	-	-	-	-	-	-	960	600	480	960	600	480
S	1	50	40	30	-	-	-	55	50	35	50	40	35	-	-	-	-	-	-
	2	50	40	30	-	-	-	55	50	35	50	40	35	-	-	-	-	-	-
	3	60	50	30	-	-	-	65	55	35	60	50	35	-	-	-	-	-	-
	4	85	60	40	80	60	40	100	70	50	80	60	40	-	-	-	-	-	-
H	1	145	110	85	-	-	-	-	-	-	-	-	-	-	-	-	-	-	-
	2	-	-	-	-	-	-	-	-	-	-	-	-	-	-	-	-	-	-
	3	-	-	-	-	-	-	-	-	-	-	-	-	-	-	-	-	-	-

NOTE: FIRST choice starting speeds are in **bold** type.
As the average chip thickness increases, the speed should be decreased.

Recommended Starting Feeds

■ Recommended Starting Feeds [mm]

Light Machining	General Purpose	Heavy Machining
-----------------	-----------------	-----------------

Insert Geometry	Programmed Feed per Tooth (fz) as a % of Radial Depth of Cut (ae)															Insert Geometry
	5%			10%			20%			30%			40-100%			
.F..LDJ	0,17	0,32	0,65	0,13	0,23	0,47	0,09	0,17	0,35	0,08	0,15	0,31	0,08	0,14	0,28	.F..LDJ
.E..LD	0,17	0,50	1,00	0,13	0,36	0,72	0,09	0,27	0,54	0,08	0,23	0,47	0,08	0,21	0,43	.E..LD
.S..GD	0,33	0,84	1,35	0,24	0,60	0,97	0,18	0,45	0,72	0,16	0,39	0,63	0,14	0,36	0,57	.S..GD
.S..HD	0,33	0,84	1,35	0,24	0,60	0,97	0,18	0,45	0,72	0,16	0,39	0,63	0,14	0,36	0,57	.S..HD

NOTE: Use "Light Machining" value as starting feed rate.

- Twelve cutting edges.
- Higher axial depth-of-cut capability with 59° lead angle.

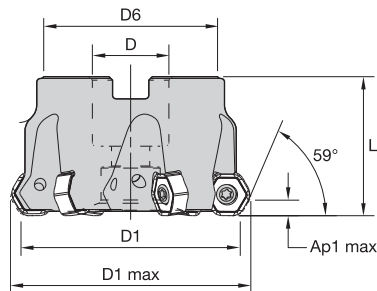
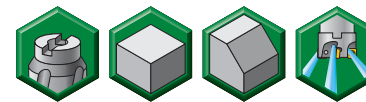

Face Mills

■ Shell Mills

order number	catalogue number	D1	D1 max	D	D6	L	Ap1 max	Z	max RPM	coolant supply	kg
4136482	M1200HD040Z04HN07	40	46,8	22	38	40	4,7	4	15800	Yes	0,22
4136863	M1200HD040Z05HN07	40	46,8	22	38	40	4,7	5	15800	Yes	0,22
4136864	M1200HD050Z04HN07	50	56,8	22	38	40	4,7	4	12700	Yes	0,34
4136865	M1200HD050Z05HN07	50	56,8	22	38	40	4,7	5	12700	Yes	0,34
4136866	M1200HD063Z04HN07	63	69,8	22	50	40	4,7	4	10100	Yes	0,58
4136867	M1200HD063Z06HN07	63	69,8	22	50	40	4,7	6	10100	Yes	0,60
4136868	M1200HD080Z05HN07	80	86,8	27	60	50	4,7	5	7900	Yes	1,11
4136869	M1200HD080Z08HN07	80	86,8	27	60	50	4,7	8	7900	Yes	1,17
4136870	M1200HD100Z06HN07	100	106,7	32	80	50	4,7	6	6300	Yes	1,74
4136871	M1200HD100Z09HN07	100	106,7	32	80	50	4,7	9	6300	Yes	1,74
4136872	M1200HD125Z08HN07	125	131,7	40	90	63	4,7	8	5050	Yes	2,86
4136873	M1200HD125Z12HN07	125	131,7	40	90	63	4,7	12	5050	Yes	2,90

■ Spare Parts

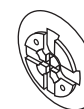

D1	insert screw	Nm	Torx driver	socket-head cap screw	mounting screw with coolant grooves	coolant screw assembly	coolant lock screw	coolant cap
40	12146034500	3,5	12148082400	—	12146109200	—	—	—
50	12146034500	3,5	12148082400	12146120500	—	—	—	—
63	12146034500	3,5	12148082400	12146120500	—	—	—	—
80	12146034500	3,5	12148082400	12748701000	—	—	—	—
100	12146034500	3,5	12148082400	—	—	12146109400	—	—
125	12146034500	3,5	12148082400	—	—	—	12146107000	12146111000

NOTE: Mounting screw with coolant groove, coolant screw assembly, coolant lock screw, and coolant cap must be ordered separately.

■ Insert Selection Guide

Material Group	Light Machining		General Purpose		Heavy Machining	
	Geometry	Grade	Geometry	Grade	Geometry	Grade
P1-P2	.E..LD	WP40PM	.S..GD	WP40PM	.S..HD	WP40PM
P3-P4	.E..LD	WP25PM	.S..GD	WP35CM	.S..HD	WP35CM
P5-P6	.E..LD	WP25PM	.S..GD	WP35CM	.S..HD	WP35CM
M1-M2	.E..LD	WP25PM	.S..GD	WP25PM	.S..HD	WP25PM
M3	.E..LD	WP35CM	.S..GD	WP35CM	.S..HD	WP35CM
K1-K2	.E..LD	TN6510	.S..GD	WK15CM	.S..HD	WK15CM
K3	.E..LD	WP35CM	.S..GD	WP35CM	.S..HD	WP35CM
N1-N2	.F..LDJ	TN6501	.F..LDJ	TN6501	.F..LDJ	TN6501
N3	.F..LDJ	TN6501	.F..LDJ	TN6501	.F..LDJ	TN6501
S1-S2	.E..LD	WS30PM	.S..GD	WS30PM	.S..HD	WP25PM
S3	.E..LD	WS30PM	.S..GD	WS30PM	.S..GD	WS30PM
S4	.E..LD	WS30PM	.S..GD	WS30PM	.S..HD	WP40PM
H1	-	-	-	-	-	-

Face Mills

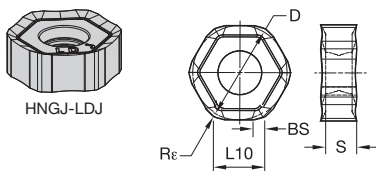

● first choice
○ alternate choice

P	●			
M	●			
K	●			
N	●	●	●	
S	●			
H				

■ HNGJ-LDJ

catalogue number	cutting edges	D	L10	S	BS	Re	hm	TN6501	THM-U
HNGJ0704ANFNLDJ	12	13	6,80	4,48	1,60	1,20	0,08	3954414	3954332

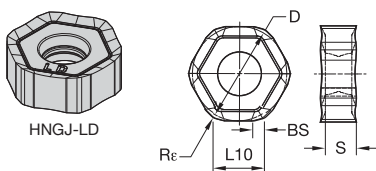

● first choice
○ alternate choice

P	●		●	●	●	●	●	●	●
M	●		○	●	○	●	●	○	●
K	●	●	○	○	○	●	○		
N	●								
S	●		●			●	●	●	○
H							○		

■ HNGJ-LD

catalogue number	cutting edges	D	L10	S	BS	Re	hm	TN6510	TN6520	TN6525	TN6540	TN7535	WK15CM	WP25PM	WP35CM	WS30PM	WP40PM
HNGJ0704ANENLD	12	13	6,80	4,48	1,60	1,20	0,08	3954419	3954420	3954421	3954422	3954430	5895291	5895292	5528975	5550905	
HNGJ070432ANENLD	12	13	6,80	4,48	-	3,20	0,08	3954428	3954429	3954430	3954430	3954430	5895291	5895292	5528975	5550905	

(Recommended Starting Speeds [m/min] – continued)

Material Group		WP25PM			WP35CM			WS30PM			WP40PM			TN6501			THM-U		
P	1	395	340	325	545	475	445	-	-	-	355	310	295	-	-	-	-	-	-
	2	330	290	240	335	305	275	-	-	-	300	260	215	-	-	-	-	-	-
	3	305	260	210	305	275	245	-	-	-	275	235	190	-	-	-	-	-	-
	4	270	220	180	230	210	190	-	-	-	245	205	160	-	-	-	-	-	-
	5	220	205	180	310	275	250	-	-	-	205	185	160	-	-	-	-	-	-
	6	200	150	120	190	160	130	-	-	-	180	140	110	-	-	-	-	-	-
M	1	245	215	200	245	220	185	270	240	220	235	205	185	-	-	-	-	-	-
	2	220	190	155	220	190	170	245	215	175	210	180	150	-	-	-	-	-	-
	3	170	145	115	175	155	140	185	160	125	155	140	110	-	-	-	-	-	-
K	1	275	245	220	355	320	290	-	-	-	-	-	-	-	-	-	-	-	-
	2	215	190	180	280	250	230	-	-	-	-	-	-	-	-	-	-	-	-
	3	180	160	145	235	210	190	-	-	-	-	-	-	-	-	-	-	-	-
N	1	-	-	-	-	-	-	-	-	-	-	-	-	2400	1440	1200	2400	1440	1200
	2	-	-	-	-	-	-	-	-	-	-	-	-	1640	980	800	1640	980	800
	3	-	-	-	-	-	-	-	-	-	-	-	-	960	600	480	960	600	480
S	1	50	40	30	-	-	-	55	50	35	50	40	35	-	-	-	-	-	-
	2	50	40	30	-	-	-	55	50	35	50	40	35	-	-	-	-	-	-
	3	60	50	30	-	-	-	65	55	35	60	50	35	-	-	-	-	-	-
	4	85	60	40	80	60	40	100	70	50	80	60	40	-	-	-	-	-	-
H	1	145	110	85	-	-	-	-	-	-	-	-	-	-	-	-	-	-	-
	2	-	-	-	-	-	-	-	-	-	-	-	-	-	-	-	-	-	-
	3	-	-	-	-	-	-	-	-	-	-	-	-	-	-	-	-	-	-

NOTE: FIRST choice starting speeds are in **bold** type.
As the average chip thickness increases, the speed should be decreased.

Recommended Starting Feeds

■ Recommended Starting Feeds [mm]

Light Machining	General Purpose	Heavy Machining
-----------------	-----------------	-----------------

Insert Geometry	Programmed Feed per Tooth (fz) as a % of Radial Depth of Cut (ae)															Insert Geometry
	5%			10%			20%			30%			40-100%			
.F..LDJ	0,14	0,26	0,53	0,10	0,19	0,38	0,08	0,14	0,29	0,07	0,12	0,25	0,06	0,11	0,23	.F..LDJ
.E..LD	0,14	0,41	0,82	0,10	0,29	0,59	0,08	0,22	0,44	0,07	0,19	0,38	0,06	0,18	0,35	.E..LD
.S..GD	0,27	0,68	1,10	0,20	0,49	0,79	0,15	0,37	0,59	0,13	0,32	0,51	0,12	0,29	0,47	.S..GD
.S..HD	0,27	0,68	1,10	0,20	0,49	0,79	0,15	0,37	0,59	0,13	0,32	0,51	0,12	0,29	0,47	.S..HD

NOTE: Use "Light Machining" value as starting feed rate.

One Series Meets Every Face Milling Need •

WIDIA™ Victory™ M1200 Series

M1200



- Low cost per edge; high productivity.
- 14.5–59° lead angles.
- One series meets every face milling need.
- Available in WIDIA premium milling grades.
- Better tool life in light to heavy machining.

Best-in-class face milling platform to boost productivity on taper 50 spindle milling machines.

Through tool coolant.

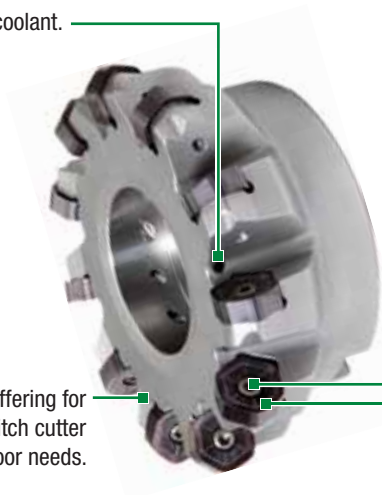

Comprehensive standard offering for coarse, medium, and fine pitch cutter bodies to match all shop floor needs.

Easy-to-use — one screw enables fast, accurate indexing.

The latest technology with twelve true cutting edges and high-precision pressed and ground inserts.

Face Mills



Victory™ M1200 HF 14.5°

Max depth of cut: 2,2mm

Lead angle: 14.5°
Indexes per insert: 12
Diameter: 50–160mm

Pages: F26–F29

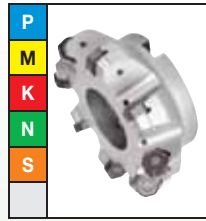

Victory™ M1200 45°

Max depth of cut: 4,5mm

Lead angle: 45°
Indexes per insert: 12
Diameter: 40–315mm

Pages: F30–F37

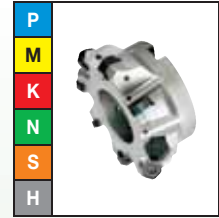

Victory™ M1200 HD 59°

Max depth of cut: 6mm

Lead angle: 59°
Indexes per insert: 12
Diameter: 50–160mm

Pages: F38–F41

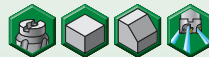

■ **Easy-to-use wiper insert setup to achieve excellent surface floor finish**

Wiper insert overlapping vs. regular insert

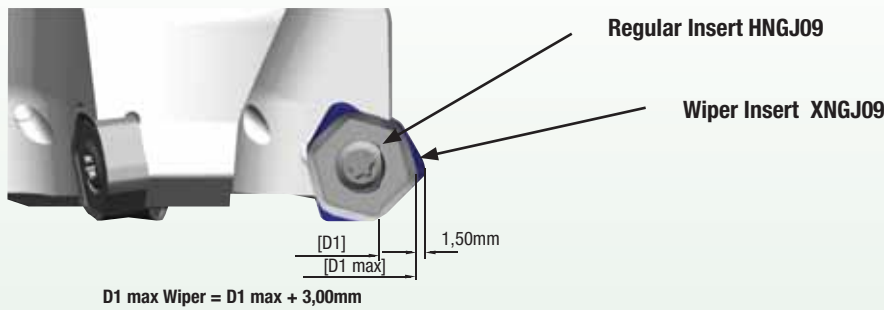

- Wiper inserts only applied with 45° lead angle cutter bodies.
- Easy to use. Regular and wiper inserts are loaded into fixed pockets. No adjustment required.
- Please have D1 max wiper in mind in case of limited working area.
- Use wiper inserts only in combination with periphery ground regular inserts HNGJ09.
- Up to cutting diameter D1=100mm load one wiper insert.
- For cutting diameter D1=125mm and above load two wiper inserts.
- Each wiper insert XNGJ09 can be applied with three right hand R and three left hand L cutting edges.

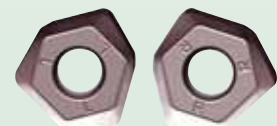

- Twelve cutting edges.
- High feed rates for rough face milling.
- Use standard M1200 inserts.
- Do not load wiper inserts.

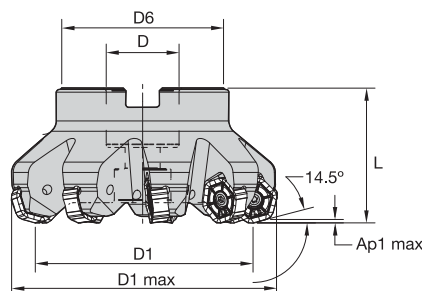
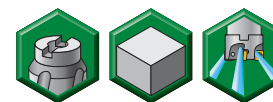

■ Shell Mills

order number	catalogue number	D1	D1 max	D	D6	L	Ap1 max	Z	max RPM	coolant supply	kg
3750370	M1200HF050Z04HN09	50	67,9	22	38	40	2,2	4	11400	Yes	0,65
3750372	M1200HF063Z05HN09	63	80,9	22	50	40	2,2	5	8950	Yes	0,65
3750434	M1200HF080Z06HN09	80	97,9	27	60	50	2,2	6	7300	Yes	1,24
3750435	M1200HF100Z08HN09	100	117,9	32	80	50	2,2	8	5900	Yes	1,89
3750436	M1200HF125Z09HN09	125	142,9	40	90	63	2,2	9	4800	Yes	3,23
3957969	M1200HF160Z12HN09	160	177,9	40	110	63	2,2	12	3900	Yes	5,14

■ Spare Parts

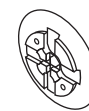

D1	insert screw	Nm	Torx driver	socket-head cap screw	socket-head cap screw with coolant groove	coolant lock screw assembly	coolant lock screw	coolant cap
50	12146034500	3,5	12148082400	12146120500	12146101000	—	—	—
63	12146034500	3,5	12148082400	12146120500	12146101000	—	—	—
80	12146034500	3,5	12148082400	12748701000	12146101800	—	—	—
100	12146034500	3,5	12148082400	—	—	12146109400	—	—
125	12146034500	3,5	12148082400	—	—	—	12146107000	12146111000
160	12146034500	3,5	12148082400	—	—	—	12146107000	12146111100

NOTE: Socket-head cap screw with coolant groove, coolant lock screw assembly, coolant lock screw, and coolant cap must be ordered separately.

■ Insert Selection Guide

Material Group	Light Machining		General Purpose		Heavy Machining	
	Geometry	Grade	Geometry	Grade	Geometry	Grade
P1-P2	.E..LD	WP40PM	.S..GD	WP40PM	.S..HD	WP40PM
P3-P4	.E..LD	WP25PM	.S..GD	WP35CM	.S..HD	WP35CM
P5-P6	.E..LD	WP25PM	.S..GD	WP35CM	.S..HD	WP35CM
M1-M2	.E..LD	WP25PM	.S..GD	WP25PM	.S..HD	WP25PM
M3	.E..LD	WP35CM	.S..GD	WP35CM	.S..HD	WP35CM
K1-K2	.E..LD	TN6520	.S..GD	WK15CM	.S..HD	WK15CM
K3	.E..LD	WP35CM	.S..GD	WP35CM	.S..HD	WP35CM
N1-N2	.F..LDJ	TN6501	.F..LDJ	TN6501	.F..LDJ	TN6501
N3	.F..LDJ	TN6501	.F..LDJ	TN6501	.F..LDJ	TN6501
S1-S2	.E..LD	WS30PM	.S..GD	WS30PM	.S..HD	WP25PM
S3	.E..LD	WS30PM	.S..GD	WS30PM	.S..HD	WP40PM
S4	.E..LD	WS30PM	.S..GD	WS30PM	.S..HD	WP40PM
H1	-	-	-	-	-	-

Face Mills

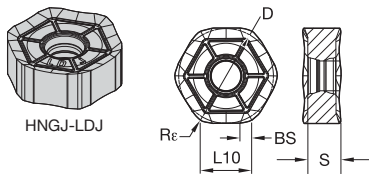

● first choice
○ alternate choice

P	●		
M	●		
K	●		
N	●	●	●
S	●		
H	●		

■ HNGJ-LDJ

catalogue number	cutting edges	D	L10	S	BS	Re	hm	TN6501	THM-U
HNGJ0905ANFNLDJ	12	16	8,58	5,56	1,80	1,20	0,02	3865373	3606383

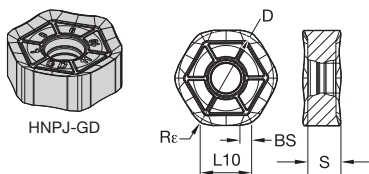

● first choice
○ alternate choice

P	●	●	●	●	●	●	●	●
M	●	○	○	○	○	○	○	○
K	●	○	○	○	○	○	○	○
N	●	○	○	○	○	○	○	○
S	●	○	○	○	○	○	○	○
H	●	○	○	○	○	○	○	○

■ HNPJ-GD

catalogue number	cutting edges	D	L10	S	BS	Re	hm	TN6520	TN6525	TN6540	TN7535	WK15CM	WP25PM	WS30PM	WP35CM	WP40PM
HNPJ0905ANSNGD	12	16	8,58	5,56	1,80	1,20	0,10	3761185	-	3761187	3761188	5427372	5895374	-	5895375	5550908

■ Recommended Starting Speeds [m/min]

Material Group		TN6520			TN6525			TN6540			TN7535			WK15CM			WP25PM		
P	1	-	-	-	410	320	280	360	280	240	545	475	445	-	-	-	395	340	325
	2	-	-	-	320	250	215	250	190	170	335	305	275	-	-	-	330	290	240
	3	-	-	-	280	215	185	215	170	140	305	275	245	-	-	-	305	260	210
	4	-	-	-	235	170	145	180	130	110	230	210	190	-	-	-	270	220	180
	5	-	-	-	310	235	200	240	180	150	310	275	250	-	-	-	220	205	180
	6	-	-	-	205	160	130	160	120	100	190	160	130	-	-	-	200	150	120
M	1	-	-	-	190	120	80	130	80	60	245	220	185	-	-	-	245	215	200
	2	-	-	-	120	80	50	80	50	40	220	190	170	-	-	-	220	190	155
	3	-	-	-	125	80	55	85	50	40	175	155	140	-	-	-	170	145	115
K	1	450	320	230	275	245	220	220	205	180	355	320	290	505	460	410	275	245	220
	2	390	250	190	215	190	180	175	155	140	280	250	230	400	355	330	215	190	180
	3	300	230	160	180	160	145	155	145	125	235	210	190	335	300	275	180	160	145
N	1	-	-	-	-	-	-	-	-	-	-	-	-	-	-	-	-	-	-
	2	-	-	-	-	-	-	-	-	-	-	-	-	-	-	-	-	-	-
	3	-	-	-	-	-	-	-	-	-	-	-	-	-	-	-	-	-	-
S	1	-	-	-	-	-	-	50	35	30	-	-	-	-	-	-	50	40	30
	2	-	-	-	-	-	-	25	20	10	-	-	-	-	-	-	50	40	30
	3	-	-	-	-	-	-	70	40	30	-	-	-	-	-	-	60	50	30
	4	-	-	-	-	-	-	60	30	25	-	-	-	-	-	-	85	60	40
H	1	-	-	-	-	-	-	-	-	-	-	-	-	-	-	-	145	110	85
	2	-	-	-	-	-	-	-	-	-	-	-	-	-	-	-	-	-	-
	3	-	-	-	-	-	-	-	-	-	-	-	-	-	-	-	-	-	-

Material Group		WS30PM			WP35CM			WP40PM			TN6501			THM-U		
P	1	-	-	-	545	475	445	355	310	295	-	-	-	-	-	-
	2	-	-	-	335	305	275	300	260	215	-	-	-	-	-	-
	3	-	-	-	305	275	245	275	235	190	-	-	-	-	-	-
	4	-	-	-	230	210	190	245	205	160	-	-	-	-	-	-
	5	-	-	-	310	275	250	205	185	160	-	-	-	-	-	-
	6	-	-	-	190	160	130	180	140	110	-	-	-	-	-	-
M	1	270	240	220	245	220	185	235	205	185	-	-	-	-	-	-
	2	245	215	175	220	190	170	210	180	150	-	-	-	-	-	-
	3	185	160	125	175	155	140	155	140	110	-	-	-	-	-	-
K	1	-	-	-	355	320	290	-	-	-	-	-	-	-	-	-
	2	-	-	-	280	250	230	-	-	-	-	-	-	-	-	-
	3	-	-	-	235	210	190	-	-	-	-	-	-	-	-	-
N	1	-	-	-	-	-	-	-	-	-	2400	1440	1200	2400	1440	1200
	2	-	-	-	-	-	-	-	-	-	1640	980	800	1640	980	800
	3	-	-	-	-	-	-	-	-	-	960	600	480	960	600	480
S	1	55	50	35	-	-	-	50	40	35	-	-	-	-	-	-
	2	55	50	35	-	-	-	50	40	35	-	-	-	-	-	-
	3	65	55	35	-	-	-	60	50	35	-	-	-	-	-	-
	4	100	70	50	80	60	40	80	60	40	-	-	-	-	-	-
H	1	-	-	-	-	-	-	-	-	-	-	-	-	-	-	-
	2	-	-	-	-	-	-	-	-	-	-	-	-	-	-	-
	3	-	-	-	-	-	-	-	-	-	-	-	-	-	-	-

NOTE: FIRST choice starting speeds are in **bold** type.
As the average chip thickness increases, the speed should be decreased.

Recommended Starting Feeds

■ Recommended Starting Feeds [mm]

Light Machining	General Purpose	Heavy Machining
-----------------	-----------------	-----------------

Insert Geometry	Programmed Feed per Tooth (fz) as a % of Radial Depth of Cut (ae)															Insert Geometry
	5%			10%			20%			30%			40-100%			
.F..LDJ	0,45	0,90	1,84	0,33	0,65	1,31	0,25	0,48	0,97	0,21	0,42	0,84	0,20	0,39	0,77	.F..LDJ
.E..LD	0,45	1,36	2,81	0,33	0,98	1,97	0,25	0,73	1,46	0,21	0,63	1,27	0,20	0,58	1,16	.E..LD
.S..GD	0,72	2,35	3,89	0,52	1,67	2,70	0,39	1,23	1,98	0,34	1,07	1,72	0,31	0,98	1,57	.S..GD
.S..HD	0,92	2,35	3,89	0,66	1,67	2,70	0,49	1,23	1,98	0,43	1,07	1,72	0,39	0,98	1,57	.S..HD

NOTE: Use "Light Machining" value as starting feed rate.

Face Mills

- Twelve cutting edges.
- First choice for general face milling.
- Low cutting forces for maximum productivity.

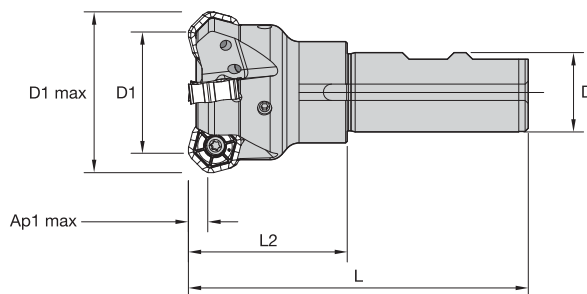
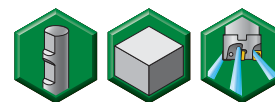

■ Weldon Shanks

order number	catalogue number	D1	D1 max	D	L	L2	Ap1 max	Z	max RPM	coolant supply	kg
3325311	M1200D040Z04B25HN09	40	51,0	25	107	50	4,5	4	15800	Yes	0,52
3325310	M1200D040Z03B25HN09	40	51,0	25	107	50	4,5	3	15800	Yes	0,53

■ Spare Parts



insert screw



Nm



Torx driver

D1	40	12146034500	3,5	12148082400
----	----	-------------	-----	-------------

- Twelve cutting edges.
- First choice for general face milling.
- Low cutting forces for maximum productivity.

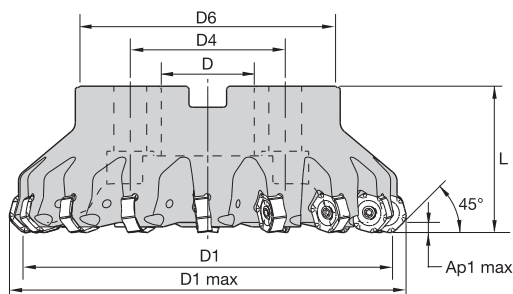

Face Mills

■ Shell Mills

order number	catalogue number	D1	D1 max	D	D4	D6	L	Ap1 max	Z	max RPM	coolant supply	kg
3957970	M1200D040Z03HN09	40	51,0	22	—	39	40	4,4	3	15800	Yes	0,26
3957971	M1200D040Z04HN09	40	51,0	22	—	39	40	4,4	4	15800	Yes	0,25
3325312	M1200D050Z04HN09	50	61,0	22	—	38	40	4,5	4	12700	Yes	0,32
3325693	M1200D050Z05HN09	50	61,0	22	—	38	40	4,5	5	12700	Yes	0,33
3650535	M1200D063Z04HN09	63	74,0	22	—	50	40	4,5	4	10100	Yes	0,59
3093594	M1200D063Z06HN09	63	74,0	22	—	50	40	4,5	6	10100	Yes	0,56
3025376	M1200D063Z07HN09	63	74,0	22	—	50	40	4,5	7	10100	Yes	0,57
3650536	M1200D080Z05HN09	80	91,0	27	—	60	50	4,5	5	7900	Yes	1,12
3081507	M1200D080Z06HN09	80	91,0	27	—	60	50	4,5	6	7900	Yes	1,07
3025377	M1200D080Z09HN09	80	91,0	27	—	60	50	4,5	9	7900	Yes	1,11
3650537	M1200D100Z06HN09	100	111,0	32	—	80	50	4,5	6	6300	Yes	1,73
3325694	M1200D100Z08HN09	100	111,0	32	—	80	50	4,5	8	6300	Yes	1,68
3025378	M1200D100Z11HN09	100	111,0	32	—	80	50	4,5	11	6300	Yes	1,73
3650538	M1200D125Z08HN09	125	135,9	40	—	90	63	4,5	8	5050	Yes	2,84
3081508	M1200D125Z10HN09	125	135,9	40	—	90	63	4,5	10	5050	Yes	2,77
3093593	M1200D125Z14HN09	125	136,0	40	—	90	63	4,5	14	5050	Yes	2,86
3066118	M1200D160Z12HN09	160	171,0	40	66,7	110	63	4,5	12	3900	Yes	4,56
3066119	M1200D160Z16HN09	160	171,0	40	66,7	110	63	4,5	16	3900	Yes	4,70
3957972	M1200D200Z16HN09	200	211,0	60	101,6	130	63	4,5	16	3180	Yes	6,43
3957993	M1200D250Z20HN09	250	261,0	60	101,6	130	63	4,5	20	2550	Yes	9,93
3957994	M1200D315Z24HN09	315	326,0	60	101,6	230	80	4,5	24	2020	Yes	22,90

(continued)

(Shell Mills – continued)

■ Spare Parts

Face Mills

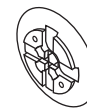

D1	insert screw	Nm	Torx driver	socket-head cap screw	socket-head cap screw with coolant groove	coolant screw assembly	coolant lock screw	coolant cap
40	12146034500	3,5	12148082400	–	12146109200	–	–	–
50	12146034500	3,5	12148082400	–	–	–	–	–
63	12146034500	3,5	12148082400	–	–	–	–	–
80	12146034500	3,5	12148082400	12748701000	–	–	–	–
100	12146034500	3,5	12148082400	–	–	12146109400	–	–
125	12146034500	3,5	12148082400	–	–	–	12146107000	1214611000
160	12146034500	3,5	12148082400	–	–	–	12146107000	1214611100
200	12146034500	3,5	12148082400	–	–	–	–	1214611200
250	12146034500	3,5	12148082400	–	–	–	–	1214611300
315	12146034500	3,5	12148082400	–	–	–	–	1214611400

NOTE: Socket-head cap screw with coolant groove, coolant screw assembly, coolant lock screw, and coolant cap must be ordered separately.

■ Insert Selection Guide

Material Group	Light Machining		General Purpose		Heavy Machining	
	Geometry	Grade	Geometry	Grade	Geometry	Grade
P1-P2	.E..LD	WP40PM	.S..GD	WP40PM	.S..HD	WP40PM
P3-P4	.E..LD	WP25PM	.S..GD	WP35CM	.S..HD	WP35CM
P5-P6	.E..LD	WP25PM	.S..GD	WP35CM	.S..HD	WP35CM
M1-M2	.E..LD	WP25PM	.S..GD	WP25PM	.S..HD	WP25PM
M3	.E..LD	WP35CM	.S..GD	WP35CM	.S..HD	WP35CM
K1-K2	.E..LD	TN6520	.S..GD	WK15CM	.S..HD	WK15CM
K3	.E..LD	WP35CM	.S..GD	WP35CM	.S..HD	WP35CM
N1-N2	.F..LDJ	TN6501	.F..LDJ	TN6501	.F..LDJ	TN6501
N3	.F..LDJ	TN6501	.F..LDJ	TN6501	.F..LDJ	TN6501
S1-S2	.E..LD	WS30PM	.S..GD	WS30PM	.S..HD	WP25PM
S3	.E..LD	WS30PM	.S..GD	WS30PM	.S..HD	WP40PM
S4	.E..LD	WS30PM	.S..GD	WS30PM	.S..HD	WP40PM
H1	-	-	-	-	-	-

Face Mills

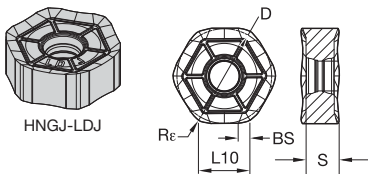

● first choice
○ alternate choice

P	●		
M	●		
K	●		
N	●	●	●
S	●		
H			

■ HNGJ-LDJ

catalogue number	cutting edges	D	L10	S	BS	Rε	hm		
								TN6501	THM-U
HNGJ0905ANFNLDJ	12	16	8,58	5,56	1,80	1,20	0,02	3865373	3606383

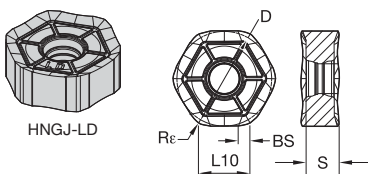

● first choice
○ alternate choice

P	●		●	●	●	●	●	●	●
M	●		○	○	○	○	○	○	○
K	●		○	○	○	○	○	○	○
N	●								
S	●		●	●	●	●	○		
H									

■ HNGJ-LD

catalogue number	cutting edges	D	L10	S	BS	Rε	hm								
								TN6520	TN6525	TN6540	TN7535	WK15CM	WP25PM	WS30PM	WP35CM
HNGJ0905ANENLD	12	16	8,58	5,56	1,80	1,20	0,05	3093559	3330950	3030034	3030017	5895346	5528973	5895347	5895348

■ Recommended Starting Speeds [m/min]

Face Mills

Material Group		TN6520			TN6525			TN6540			TN7535			WK15CM			WP25PM		
P	1	-	-	-	410	320	280	360	280	240	545	475	445	-	-	-	395	340	325
	2	-	-	-	320	250	215	250	190	170	335	305	275	-	-	-	330	290	240
	3	-	-	-	280	215	185	215	170	140	305	275	245	-	-	-	305	260	210
	4	-	-	-	235	170	145	180	130	110	230	210	190	-	-	-	270	220	180
	5	-	-	-	310	235	200	240	180	150	310	275	250	-	-	-	220	205	180
	6	-	-	-	205	160	130	160	120	100	190	160	130	-	-	-	200	150	120
M	1	-	-	-	190	120	80	130	80	60	245	220	185	-	-	-	245	215	200
	2	-	-	-	120	80	50	80	50	40	220	190	170	-	-	-	220	190	155
	3	-	-	-	125	80	55	85	50	40	175	155	140	-	-	-	170	145	115
K	1	450	320	230	275	245	220	220	205	180	355	320	290	505	460	410	275	245	220
	2	390	250	190	215	190	180	175	155	140	280	250	230	400	355	330	215	190	180
	3	300	230	160	180	160	145	155	145	125	235	210	190	335	300	275	180	160	145
N	1	-	-	-	-	-	-	-	-	-	-	-	-	-	-	-	-	-	-
	2	-	-	-	-	-	-	-	-	-	-	-	-	-	-	-	-	-	-
	3	-	-	-	-	-	-	-	-	-	-	-	-	-	-	-	-	-	-
S	1	-	-	-	-	-	-	50	35	30	-	-	-	-	-	-	50	40	30
	2	-	-	-	-	-	-	25	20	10	-	-	-	-	-	-	50	40	30
	3	-	-	-	-	-	-	70	40	30	-	-	-	-	-	-	60	50	30
	4	-	-	-	-	-	-	60	30	25	-	-	-	-	-	-	85	60	40
H	1	-	-	-	-	-	-	-	-	-	-	-	-	-	-	-	145	110	85
	2	-	-	-	-	-	-	-	-	-	-	-	-	-	-	-	-	-	-
	3	-	-	-	-	-	-	-	-	-	-	-	-	-	-	-	-	-	-

(continued)

(Recommended Starting Speeds [m/min] – continued)

Material Group		WS30PM			WP35CM			WP40PM			WK25YM			TN6501			THM-U		
P	1	-	-	-	545	475	445	355	310	295	-	-	-	-	-	-	-	-	-
	2	-	-	-	335	305	275	300	260	215	-	-	-	-	-	-	-	-	-
	3	-	-	-	305	275	245	275	235	190	-	-	-	-	-	-	-	-	-
	4	-	-	-	230	210	190	245	205	160	-	-	-	-	-	-	-	-	-
	5	-	-	-	310	275	250	205	185	160	-	-	-	-	-	-	-	-	-
	6	-	-	-	190	160	130	180	140	110	-	-	-	-	-	-	-	-	-
M	1	270	240	220	245	220	185	235	205	185	-	-	-	-	-	-	-	-	-
	2	245	215	175	220	190	170	210	180	150	-	-	-	-	-	-	-	-	-
	3	185	160	125	175	155	140	155	140	110	-	-	-	-	-	-	-	-	-
K	1	-	-	-	355	320	290	-	-	-	965	880	780	-	-	-	-	-	-
	2	-	-	-	280	250	230	-	-	-	765	685	635	-	-	-	-	-	-
	3	-	-	-	235	210	190	-	-	-	645	570	525	-	-	-	-	-	-
N	1	-	-	-	-	-	-	-	-	-	-	-	-	2400	1440	1200	2400	1440	1200
	2	-	-	-	-	-	-	-	-	-	-	-	-	1640	980	800	1640	980	800
	3	-	-	-	-	-	-	-	-	-	-	-	-	960	600	480	960	600	480
S	1	55	50	35	-	-	-	50	40	35	-	-	-	-	-	-	-	-	-
	2	55	50	35	-	-	-	50	40	35	-	-	-	-	-	-	-	-	-
	3	65	55	35	-	-	-	60	50	35	-	-	-	-	-	-	-	-	-
	4	100	70	50	80	60	40	80	60	40	-	-	-	-	-	-	-	-	-
H	1	-	-	-	-	-	-	-	-	-	-	-	-	-	-	-	-	-	-
	2	-	-	-	-	-	-	-	-	-	-	-	-	-	-	-	-	-	-
	3	-	-	-	-	-	-	-	-	-	-	-	-	-	-	-	-	-	-

NOTE: FIRST choice starting speeds are in **bold** type.
As the average chip thickness increases, the speed should be decreased.

Recommended Starting Feeds

■ Recommended Starting Feeds [mm]

Light Machining	General Purpose	Heavy Machining
-----------------	-----------------	-----------------

Insert Geometry	Programmed Feed per Tooth (fz) as a % of Radial Depth of Cut (ae)															Insert Geometry
	5%			10%			20%			30%			40-100%			
.F..LDJ	0,17	0,33	0,66	0,12	0,24	0,47	0,09	0,18	0,35	0,08	0,15	0,31	0,07	0,14	0,28	.F..LDJ
.E..LD	0,17	0,49	0,99	0,12	0,35	0,71	0,09	0,27	0,53	0,08	0,23	0,46	0,07	0,21	0,42	.E..LD
.S..GD	0,26	0,84	1,35	0,19	0,60	0,97	0,14	0,45	0,72	0,12	0,39	0,63	0,11	0,36	0,57	.S..GD
.S..HD	0,33	0,84	1,35	0,24	0,60	0,97	0,18	0,45	0,72	0,16	0,39	0,63	0,14	0,36	0,57	.S..HD
.S..Ceramic	0,17	0,33	0,49	0,12	0,24	0,35	0,09	0,18	0,27	0,08	0,15	0,23	0,07	0,14	0,21	.S..Ceramic

NOTE: Use "Light Machining" value as starting feed rate.

- Twelve cutting edges.
- Higher $A_{p1 \max}$ with standard insert.

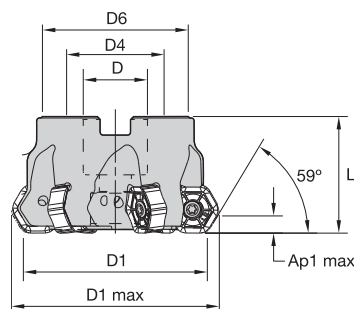
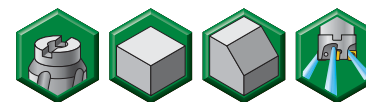

Face Mills

■ Shell Mills

order number	catalogue number	D1	D1 max	D	D4	D6	L	$A_{p1 \max}$	Z	max RPM	coolant supply	kg
4152113	M1200HD050Z04HN09	50	58,6	22	—	38	40	6,0	4	12700	Yes	0,29
4152114	M1200HD050Z05HN09	50	58,6	22	—	38	40	6,0	5	12700	Yes	0,28
4152115	M1200HD063Z04HN09	63	71,5	22	—	50	40	6,0	4	10100	Yes	0,54
4152116	M1200HD063Z06HN09	63	71,5	22	—	50	40	6,0	6	10100	Yes	0,55
4152117	M1200HD080Z05HN09	80	88,5	27	—	60	50	6,0	5	7900	Yes	1,05
4152118	M1200HD080Z08HN09	80	88,5	27	—	60	50	6,0	8	7900	Yes	1,10
4152119	M1200HD100Z06HN09	100	108,5	32	—	80	50	6,0	6	6300	Yes	1,61
4152120	M1200HD100Z08HN09	100	108,5	32	—	80	50	6,0	8	6300	Yes	1,63
4152121	M1200HD125Z08HN09	125	133,5	40	—	90	63	6,0	8	5050	Yes	2,88
4152122	M1200HD125Z10HN09	125	133,5	40	—	90	63	6,0	10	5050	Yes	2,85
4152123	M1200HD160Z09HN09	160	168,5	40	66,7	110	63	6,0	9	3900	Yes	4,62
4152124	M1200HD160Z12HN09	160	168,5	40	66,7	110	63	6,0	12	3900	Yes	4,75

■ Spare Parts

D1	insert screw	Nm	Torx driver	socket-head cap screw	coolant screw assembly	coolant lock screw	coolant cap
50	12146034500	3,5	12148082400	12146120500	—	—	—
63	12146034500	3,5	12148082400	12146120500	—	—	—
80	12146034500	3,5	12148082400	12748701000	—	—	—
100	12146034500	3,5	12148082400	—	12146109400	—	—
125	12146034500	3,5	12148082400	—	—	12146107000	12146111000
160	12146034500	3,5	12148082400	—	—	12146107000	12146111100

NOTE: Coolant screw assembly, coolant lock screw, and coolant cap must be ordered separately.

■ Insert Selection Guide

Material Group	Light Machining		General Purpose		Heavy Machining	
	Geometry	Grade	Geometry	Grade	Geometry	Grade
P1-P2	.E..LD	WP40PM	.S..GD	WP40PM	.S..HD	WP40PM
P3-P4	.E..LD	WP25PM	.S..GD	WP35CM	.S..HD	WP35CM
P5-P6	.E..LD	WP25PM	.S..GD	WP35CM	.S..HD	WP35CM
M1-M2	.E..LD	WP25PM	.S..GD	WP25PM	.S..HD	WP25PM
M3	.E..LD	WP35CM	.S..GD	WP35CM	.S..HD	WP35CM
K1-K2	.E..LD	TN6520	.S..GD	WK15CM	.S..HD	WK15CM
K3	.E..LD	WP35CM	.S..GD	WP35CM	.S..HD	WP35CM
N1-N2	.F..LDJ	TN6501	.F..LDJ	TN6501	.F..LDJ	TN6501
N3	.F..LDJ	TN6501	.F..LDJ	TN6501	.F..LDJ	TN6501
S1-S2	.E..LD	WS30PM	.S..GD	WS30PM	.S..HD	WP25PM
S3	.E..LD	WS30PM	.S..GD	WS30PM	.S..HD	WP40PM
S4	.E..LD	WS30PM	.S..GD	WS30PM	.S..HD	WP40PM
H1	-	-	-	-	-	-

Face Mills

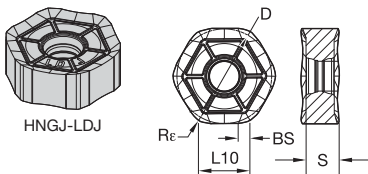

● first choice
○ alternate choice

P	●		
M	●		
K	●		
N	●	●	●
S	●		
H	●		

■ HNGJ-LDJ

catalogue number	cutting edges	D	L10	S	BS	Re	hm	TN6501	THM-U
HNGJ0905ANFNLDJ	12	16	8,58	5,56	1,80	1,20	0,02	3865373	3606383

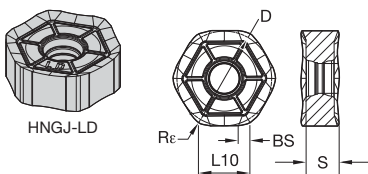

● first choice
○ alternate choice

P	●	●	●	●	●	●	●	●
M	●	○	○	○	○	○	○	○
K	●	○	○	○	○	○	○	○
N	●							
S	●	●	●	●	●	●	○	○
H	●							

■ HNGJ-LD

catalogue number	cutting edges	D	L10	S	BS	Re	hm	TN6520	TN6525	TN6540	TN7535	WP25PM	WK15CM	WS30PM	WP35CM	WP40PM
HNGJ0905ANENLD	12	16	8,58	5,56	1,80	1,20	0,05	3093559	3330950	3030034	3090017	5895346	I	5528973	5895347	5895348

■ Recommended Starting Speeds [m/min]

Material Group		TN6501	TN6520	TN6525	TN6540	TN7535	WP25PM
P	1	- - -	- - -	410 320 280	360 280 240	545 475 445	1295 1120 1060
	2	- - -	- - -	320 250 215	250 190 170	335 305 275	1080 940 785
	3	- - -	- - -	280 215 185	215 170 140	305 275 245	1000 845 690
	4	- - -	- - -	235 170 145	180 130 110	230 210 190	890 725 590
	5	- - -	- - -	310 235 200	240 180 150	310 275 250	725 670 590
	6	- - -	- - -	205 160 130	160 120 100	190 160 130	650 490 395
M	1	- - -	- - -	190 120 80	130 80 60	245 220 185	805 710 650
	2	- - -	- - -	120 80 50	80 50 40	220 190 170	725 630 510
	3	- - -	- - -	125 80 55	85 50 40	175 155 140	550 475 370
K	1	- - -	450 320 230	275 245 220	220 205 180	355 320 290	905 805 725
	2	- - -	390 250 190	215 190 180	175 155 140	280 250 230	710 630 590
	3	- - -	300 230 160	180 160 145	155 145 125	235 210 190	590 535 475
N	1	2400 1440 1200	- - -	- - -	- - -	- - -	- - -
	2	1640 980 800	- - -	- - -	- - -	- - -	- - -
	3	960 600 480	- - -	- - -	- - -	- - -	- - -
S	1	- - -	- - -	- - -	50 35 30	- - -	155 140 95
	2	- - -	- - -	- - -	25 20 10	- - -	155 140 95
	3	- - -	- - -	- - -	70 40 30	- - -	200 155 95
	4	- - -	- - -	- - -	60 30 25	- - -	275 200 140
H	1	- - -	- - -	- - -	- - -	- - -	475 355 275
	2	- - -	- - -	- - -	- - -	- - -	- - -
	3	- - -	- - -	- - -	- - -	- - -	- - -

Material Group		WK15CM	WS30PM	WP35CM	WP40PM	TN6501	THM-U
P	1	- - -	- - -	545 475 445	355 310 295	- - -	- - -
	2	- - -	- - -	335 305 275	300 260 215	- - -	- - -
	3	- - -	- - -	305 275 245	275 235 190	- - -	- - -
	4	- - -	- - -	230 210 190	245 205 160	- - -	- - -
	5	- - -	- - -	310 275 250	205 185 160	- - -	- - -
	6	- - -	- - -	190 160 130	180 140 110	- - -	- - -
M	1	- - -	270 240 220	245 220 185	235 205 185	- - -	- - -
	2	- - -	245 215 175	220 190 170	210 180 150	- - -	- - -
	3	- - -	185 160 125	175 155 140	155 140 110	- - -	- - -
K	1	505 460 410	- - -	355 320 290	- - -	- - -	- - -
	2	400 355 330	- - -	280 250 230	- - -	- - -	- - -
	3	335 300 275	- - -	235 210 190	- - -	- - -	- - -
N	1	- - -	- - -	- - -	- - -	2400 1440 1200	2400 1440 1200
	2	- - -	- - -	- - -	- - -	1640 980 800	1640 980 800
	3	- - -	- - -	- - -	- - -	960 600 480	960 600 480
S	1	- - -	55 50 35	- - -	50 40 35	- - -	- - -
	2	- - -	55 50 35	- - -	50 40 35	- - -	- - -
	3	- - -	65 55 35	- - -	60 50 35	- - -	- - -
	4	- - -	100 70 50	80 60 40	80 60 40	- - -	- - -
H	1	- - -	- - -	- - -	- - -	- - -	- - -
	2	- - -	- - -	- - -	- - -	- - -	- - -
	3	- - -	- - -	- - -	- - -	- - -	- - -

NOTE: FIRST choice starting speeds are in **bold** type.
As the average chip thickness increases, the speed should be decreased.

Recommended Starting Feeds

■ Recommended Starting Feeds [mm]

Light Machining	General Purpose	Heavy Machining
-----------------	-----------------	-----------------

Insert Geometry	Programmed Feed per Tooth (fz) as a % of Radial Depth of Cut (ae)															Insert Geometry
	5%			10%			20%			30%			40-100%			
.F..LDJ	0,13	0,27	0,54	0,10	0,19	0,39	0,07	0,14	0,29	0,06	0,13	0,25	0,06	0,12	0,23	.F..LDJ
.E..LD	0,13	0,40	0,81	0,10	0,29	0,58	0,07	0,22	0,43	0,06	0,19	0,38	0,06	0,17	0,35	.E..LD
.S..GD	0,21	0,68	1,10	0,15	0,49	0,79	0,12	0,37	0,59	0,10	0,32	0,51	0,09	0,29	0,47	.S..GD
.S..HD	0,27	0,68	1,10	0,20	0,49	0,79	0,15	0,37	0,59	0,13	0,32	0,51	0,12	0,29	0,47	.S..HD

NOTE: Use "Light Machining" value as starting feed rate.

When Low Cutting Forces Are Required •

M640 Series

M640



The M640 platform is the first choice when high productivity, superior finish operations, and soft cutting performance are a priority. With six effective cutting edges and a streamlined body design, this easy-to-use tool is ideal, even for low-power machines.

- Highly positive rake angle means extremely low cutting forces.
- Available in geometries and grades for all applications.
- Easy-to-use for fast, accurate indexing.

All pockets are machined into preheated material for excellent runout and pocket strength.

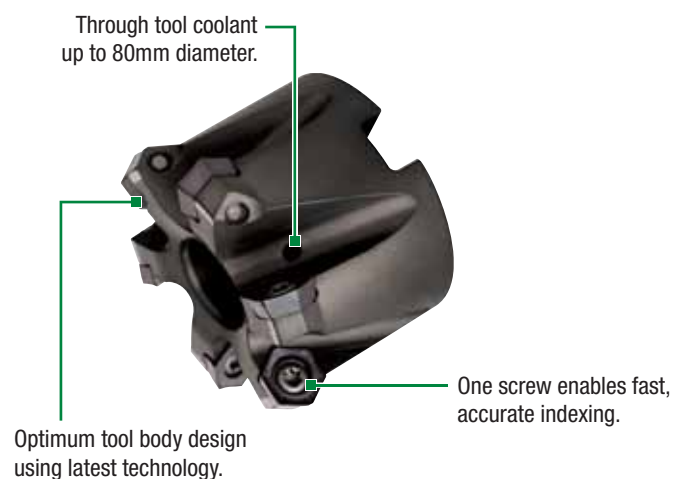

Face Mills



M640

Max depth of cut: 4,8mm

Lead angle: 58°

Indexes per insert: 6

Diameter: 32–125mm

Pages: F44–F49

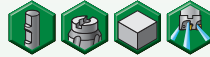

■ Insert Offering



Low cutting force wiper inserts:
Special wiper design for very soft cutting in finishing operations with high productivity.



Six effective cutting edges.

Highly positive rake:

- Extremely low cutting forces.
- For low-power machines, driven units, and light fixtures.
- Chipbreaker and grades for all applications.
- Through tool coolant up to 80mm diameter.

- Six cutting edges.
- Highly positive rake for low-power machines or light fixtures.
- Geometries and grades for all applications.

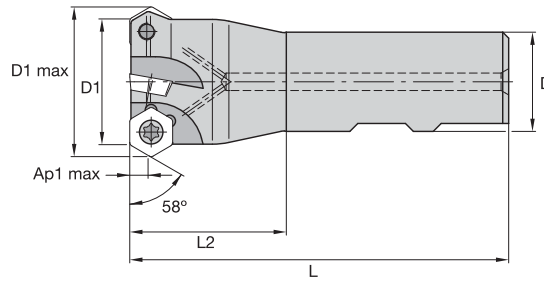
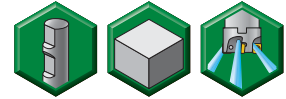

■ Weldon Shanks

order number	catalogue number	D1	D1 max	D	L	L2	Ap1 max	Z	max RPM	coolant supply	kg
2263165	12395405200	32	38,4	32	100	40	4,8	4	29500	Yes	0,35

■ Spare Parts



insert screw



Nm



Torx driver

D1	32	12148038800	4,0	1214800600
----	----	-------------	-----	------------

- Six cutting edges.
- Highly positive rake for low-power machines or light fixtures.
- Geometries and grades for all applications.



Face Mills

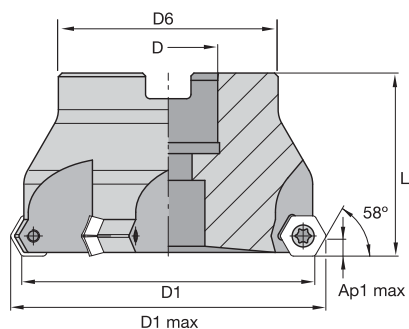

■ Shell Mills

order number	catalogue number	D1	D1 max	D	D6	L	Ap1 max	Z	max RPM	coolant supply	kg
2263132	12395410200	50	56,4	22	47	40	4,8	4	19000	Yes	0,40
2263154	12395410400	63	69,4	22	50	40	4,8	5	15000	Yes	0,55
2263156	12395410600	80	86,4	27	60	50	4,8	6	11500	Yes	1,05
2263158	12395410800	100	106,4	32	78	50	4,8	7	9500	No	1,50
2263159	12395415800	100	106,4	32	78	50	4,8	10	9500	No	1,65
2263160	12395411000	125	131,4	40	89	63	4,8	8	7500	No	2,90

■ Spare Parts



insert screw



Nm



Torx driver

D1	insert screw	Nm	Torx driver
50	12148038800	4,0	12148000600
63	12148038800	4,0	12148000600
80	12148038800	4,0	12148000600
100	12148038800	4,0	12148000600
125	12148038800	4,0	12148000600

■ Insert Selection Guide

Material Group	Light Machining		General Purpose		Heavy Machining	
	Geometry	Grade	Geometry	Grade	Geometry	Grade
P1-P2	.E..LD	WP40PM	.E..GD	WP40PM	.E..GD	WP40PM
P3-P4	.E..LD	WP25PM	.E..GD	WP35CM	.E..GD	WP35CM
P5-P6	.E..LD	WP25PM	.E..GD	WP35CM	.E..GD	WP35CM
M1-M2	.E..LD	WP25PM	.E..GD	WP25PM	.E..GD	WP25PM
M3	.E..LD	WP40PM	.E..GD	WP35CM	.E..GD	WP35CM
K1-K2	.E..LD	TN6510	.E..GD	WK15CM	.E..GD	WK15CM
K3	.E..LD	TN6520	.E..GD	WP35CM	.E..GD	WP35CM
N1-N2	.F..LDAL	TN6501	.F..LDAL	TN6501	.F..LDAL	TN6501
N3	.F..LDAL	TN6501	.F..LDAL	TN6501	.F..LDAL	TN6501
S1-S2	.E..LD	WP25PM	.E..GD	WP25PM	.E..GD	WP25PM
S3	.E..GD	WS30PM	.E..GD	WS30PM	.E..GD	WP40PM
S4	.E..GD	WS30PM	.E..GD	WS30PM	.E..GD	WP40PM
H1	.E..LD	TN2510	.E..GD	TN2510	-	-

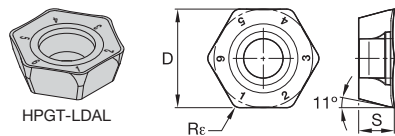

● first choice
○ alternate choice

P	●			
M	●			
K	●			○
N	●	●	●	
S	●			○
H	●			

■ HPGT-LDAL

catalogue number	cutting edges	D	S	Rr	hm	TN6501	THM-U	THM
HPGT06T3DZFRDLAL	6	11	4,00	0,90	0,08	2957548	2288107	2288106

NOTE: Ap1 max = 3,2mm with this geometry.

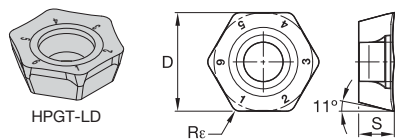

● first choice
○ alternate choice

P	●							
M	●							
K	●							
N	●							
S	●							
H	●							

■ HPGT-LD

catalogue number	cutting edges	D	S	Rr	hm	TN2510	TN6510	TN6520	TN6525	TN6540	TN7525	TN7535	WK15CM	WP25PM	WS30PM	WP35CM	WP40PM
HPGT06T3DZERLD	6	11	3,99	0,98	0,08	2288072	2957585	2957547	2957587	2288070	2288070	2288070	5895784	5895784	5895784	5895784	5895785

NOTE: Ap1 max = 3mm with this geometry.

■ Recommended Starting Speeds [m/min]

Face Mills

Material Group		TN2510			TN6510			TN6520			TN6525			TN6540			TN7525		
P	1	660	580	540	-	-	-	-	-	-	410	320	280	360	280	240	410	310	280
	2	410	370	330	-	-	-	-	-	-	320	250	215	250	190	170	310	250	215
	3	370	330	305	-	-	-	-	-	-	280	215	185	215	170	140	280	215	185
	4	275	260	230	-	-	-	-	-	-	235	170	145	180	130	110	235	170	145
	5	330	300	275	-	-	-	-	-	-	310	235	200	240	180	150	310	235	200
	6	230	205	175	-	-	-	-	-	-	205	160	130	160	120	100	205	160	130
M	1	270	240	210	-	-	-	-	-	-	190	120	80	130	80	60	245	220	185
	2	245	210	190	-	-	-	-	-	-	120	80	50	80	50	40	220	190	170
	3	190	175	150	-	-	-	-	-	-	125	80	55	85	50	40	175	155	140
K	1	420	360	300	480	350	260	450	320	230	275	245	220	220	205	180	380	280	240
	2	360	300	250	420	280	205	390	250	190	215	190	180	175	155	140	325	240	200
	3	300	250	200	335	260	200	300	230	160	180	160	145	155	145	125	240	200	170
N	1	-	-	-	-	-	-	-	-	-	-	-	-	-	-	-	-	-	-
	2	-	-	-	-	-	-	-	-	-	-	-	-	-	-	-	-	-	-
	3	-	-	-	-	-	-	-	-	-	-	-	-	-	-	-	-	-	-
S	1	-	-	-	-	-	-	-	-	-	-	-	-	50	35	30	-	-	-
	2	-	-	-	-	-	-	-	-	-	-	-	-	25	20	10	-	-	-
	3	-	-	-	-	-	-	-	-	-	-	-	-	70	40	30	-	-	-
	4	-	-	-	-	-	-	-	-	-	-	-	-	60	30	25	-	-	-
H	1	145	110	70	-	-	-	-	-	-	-	-	-	-	-	-	-	-	-
	2	145	110	70	-	-	-	-	-	-	-	-	-	-	-	-	-	-	-
	3	115	80	45	-	-	-	-	-	-	-	-	-	-	-	-	-	-	-

Material Group		TN7535			WK15CM			WP25PM			WS30PM			WP35CM			WP40PM		
P	1	545	475	445	-	-	-	395	340	325	-	-	-	545	475	445	355	310	295
	2	335	305	275	-	-	-	330	290	240	-	-	-	335	305	275	300	260	215
	3	305	275	245	-	-	-	305	260	210	-	-	-	305	275	245	275	235	190
	4	230	210	190	-	-	-	270	220	180	-	-	-	230	210	190	245	205	160
	5	310	275	250	-	-	-	220	205	180	-	-	-	310	275	250	205	185	160
	6	190	160	130	-	-	-	200	150	120	-	-	-	190	160	130	180	140	110
M	1	245	220	185	-	-	-	245	215	200	270	240	220	245	220	185	235	205	185
	2	220	190	170	-	-	-	220	190	155	245	215	175	220	190	170	210	180	150
	3	175	155	140	-	-	-	170	145	115	185	160	125	175	155	140	155	140	110
K	1	355	320	290	505	460	410	275	245	220	-	-	-	355	320	290	-	-	-
	2	280	250	230	400	355	330	215	190	180	-	-	-	280	250	230	-	-	-
	3	235	210	190	335	300	275	180	160	145	-	-	-	235	210	190	-	-	-
N	1	-	-	-	-	-	-	-	-	-	-	-	-	-	-	-	-	-	-
	2	-	-	-	-	-	-	-	-	-	-	-	-	-	-	-	-	-	-
	3	-	-	-	-	-	-	-	-	-	-	-	-	-	-	-	-	-	-
S	1	-	-	-	-	-	-	50	40	30	55	50	35	-	-	-	50	40	35
	2	-	-	-	-	-	-	50	40	30	55	50	35	-	-	-	50	40	35
	3	-	-	-	-	-	-	60	50	30	65	55	35	-	-	-	60	50	35
	4	-	-	-	-	-	-	85	60	40	100	70	50	80	60	40	80	60	40
H	1	-	-	-	-	-	-	-	-	-	-	-	-	-	-	-	-	-	-
	2	-	-	-	-	-	-	-	-	-	-	-	-	-	-	-	-	-	-
	3	-	-	-	-	-	-	-	-	-	-	-	-	-	-	-	-	-	-

(continued)

(Recommended Starting Speeds [m/min] – continued)

Material Group		TN6501			THM-U			THM		
P	1	-	-	-	-	-	-	-	-	-
	2	-	-	-	-	-	-	-	-	-
	3	-	-	-	-	-	-	-	-	-
	4	-	-	-	-	-	-	-	-	-
	5	-	-	-	-	-	-	-	-	-
	6	-	-	-	-	-	-	-	-	-
M	1	-	-	-	-	-	-	-	-	-
	2	-	-	-	-	-	-	-	-	-
	3	-	-	-	-	-	-	-	-	-
K	1	-	-	-	230	205	180	145	110	90
	2	-	-	-	-	-	-	150	120	85
	3	-	-	-	-	-	-	155	115	70
N	1	2400	1440	1200	2400	1440	1200	1080	720	600
	2	1640	980	800	1640	980	800	820	560	460
	3	960	600	480	960	600	480	540	335	240
S	1	-	-	-	-	-	-	-	-	-
	2	-	-	-	-	-	-	-	-	-
	3	-	-	-	-	-	-	-	-	-
	4	-	-	-	-	-	-	-	-	-
H	1	-	-	-	-	-	-	-	-	-
	2	-	-	-	-	-	-	-	-	-
	3	-	-	-	-	-	-	-	-	-

NOTE: FIRST choice starting speeds are in **bold** type.
As the average chip thickness increases, the speed should be decreased.

Recommended Starting Feeds

■ Recommended Starting Feeds [mm]

Light Machining	General Purpose	Heavy Machining
-----------------	-----------------	-----------------

Insert Geometry	Programmed Feed per Tooth (fz) as a % of Radial Depth of Cut (ae)															Insert Geometry
	5%			10%			20%			30%			40-100%			
.F..LDAL	0,13	0,34	0,47	0,10	0,25	0,34	0,07	0,18	0,25	0,06	0,16	0,22	0,06	0,15	0,20	.F..LDAL
.E..LD	0,13	0,34	0,47	0,10	0,25	0,34	0,07	0,18	0,25	0,06	0,16	0,22	0,06	0,15	0,20	.E..LD
.E..GD	0,13	0,48	0,54	0,10	0,35	0,39	0,07	0,26	0,29	0,06	0,23	0,25	0,06	0,21	0,23	.E..GD

NOTE: Use "Light Machining" value as starting feed rate.

The Ideal Heavy-Duty Face Milling Platform •
M660 Series

M660



The M660 Series heavy-duty face milling platform, with its strong tool body design and perfect axial and radial runout, is the ultimate high-performance booster in the heavy machining of steel and cast iron.

- Three tailor-made chipbreakers with large chip gash ensures excellent chip evacuation.
- Easy, safe, and stable clamping ensures accurate indexing.
- Thick inserts for reliability and high MRR capability.

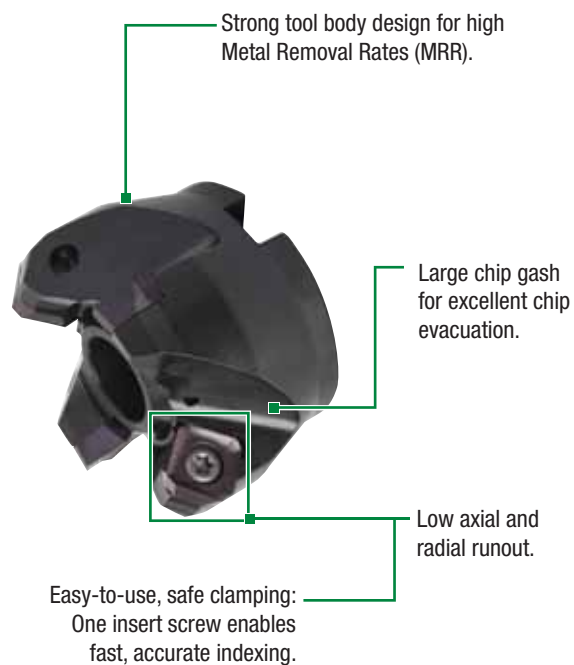

Face Mills



M660 SN1205..

Max depth of cut: 6,4mm

Lead angle: 45°
Indexes per insert: 4
Diameter: 20–160mm

Pages: F52–F57

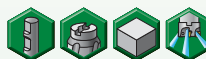

M660 SN1505..

Max depth of cut: 8,4mm

Lead angle: 45°
Indexes per insert: 4
Diameter: 100mm

Pages: F58–F60



■ Insert Offering



Three tailor-made chipbreakers (-20, -21, -31) for all heavy-duty applications in steel and cast iron.

Thick inserts for reliability and high MRR capability.

Integrated wiper facet: Good surface finish in heavy roughing applications.

Positive rake angle:

- Soft cutting action.
- Less spindle power requirement.
- Less chipping on workpiece in cast iron.
- Less burrs on workpiece in steel.
- High feed rate capability.

- Four cutting edges.
- Strong tool body design.
- Excellent chip evacuation.

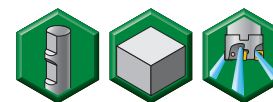

Face Mills

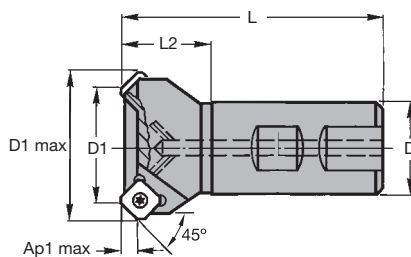

■ Weldon Shanks

order number	catalogue number	D1	D1 max	D	L	L2	Ap1 max	Z	max RPM	coolant supply	kg
2002367	12396202200	20	33,8	25	86	30	6,4	2	17000	Yes	0,30
2002370	12396202600	25	38,7	25	91	35	6,4	2	15000	Yes	0,35

■ Spare Parts



D1	insert screw	Nm	Torx driver
20	12148007200	3,5	12148007500
25	12148007200	3,5	12148007500

- Four cutting edges.
- Strong tool body design.
- Excellent chip evacuation.

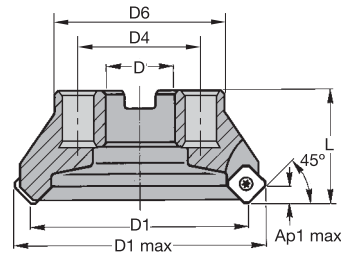

Face Mills

■ Shell Mills

order number	catalogue number	D1	D1 max	D	D4	D6	L	Ap1 max	Z	max RPM	coolant supply	kg
2003541	12396203800	50	63,5	22	—	50	40	6,4	4	12500	Yes	0,45
2003558	12396204200	63	76,5	22	—	50	40	6,4	5	11000	Yes	0,60
2003575	12396204600	80	94,3	27	—	60	50	6,4	6	9900	Yes	1,15
2003582	12396205000	100	113,4	32	—	78	50	6,4	7	8900	No	1,60
2003679	12396205400	125	138,3	40	—	89	63	6,4	8	7900	No	2,80
2003780	12396205800	160	173,3	40	66,7	90	63	6,4	10	7000	No	4,10

■ Spare Parts



D1	insert screw	Nm	Torx driver
50	12148007200	3,5	12148007500
63	12148007200	3,5	12148007500
80	12148007200	3,5	12148007500
100	12148007200	3,5	12148007500
125	12148007200	3,5	12148007500
160	12148007200	3,5	12148007500

■ Insert Selection Guide

Material Group	Light Machining		General Purpose		Heavy Machining	
	Geometry	Grade	Geometry	Grade	Geometry	Grade
P1-P2	...20	TN6540	...31	WP40PM	...31	WP40PM
P3-P4	...20	TN7535	...31	WP35CM	...31	WP35CM
P5-P6	...20	TN7535	...31	WP35CM	...31	WP35CM
M1-M2	...20	TN6540	...31	WP25PM	...31	WP25PM
M3	...20	TN7535	...31	WP35CM	...31	WP35CM
K1-K2	...21	WK15CM	...31	WK15CM	...31	WK15CM
K3	...21	WK15CM	...31	WP35CM	...31	WP35CM
N1-N2	-	-	-	-	-	-
N3	-	-	-	-	-	-
S1-S2	...20	TN6540	...31	WP25PM	...31	WP25PM
S3	-	-	-	-	-	-
S4	...20	TN6540	...31	WP40PM	...31	WP40PM
H1	-	-	-	-	-	-

Inserts • SN1205..

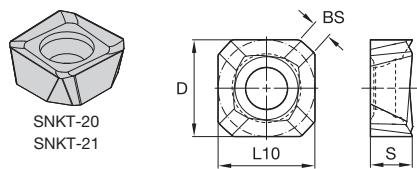

● first choice
○ alternate choice

P	●	●	●	●	●	●	●
M	●	○	○	○	○	○	○
K	○	○	○	●	○	○	○
N	○	○	○	○	○	○	●
S	●	○	○	○	○	○	○
H	○	○	○	○	○	○	○

■ SNKT-20

catalogue number	cutting edges	D	L10	S	BS	hm	TN6540	TN7525	TN7535	WK15CM	WP40PM	TT125	THM
SNKT1205AZER20	4	12,70	12,70	5,51	2,00	0,10	2964201	2022370	2020691	-	-	2022371	-

■ SNKT-21

catalogue number	cutting edges	D	L10	S	BS	hm	TN6540	TN7525	TN7535	WK15CM	WP40PM	TT125	THM
SNKT1205AZR21	4	12,70	12,70	5,56	1,54	0,15	-	2022373	-	5427383	-	2022374	2022375

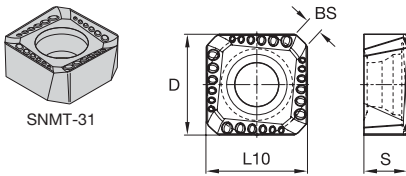

● first choice
○ alternate choice

P	●	●	●	●	●	●	●	●	●	●
M	○	○	○	○	○	○	○	○	○	○
K	○	○	○	○	○	○	○	○	○	○
N	○	○	○	○	○	○	○	○	○	○
S	●	○	○	○	○	○	○	○	○	○
H	○	○	○	○	○	○	○	○	○	○

■ SNMT-31

catalogue number	cutting edges	D	L10	S	BS	hm	TN6525	TN6540	TN7525	TN7535	WK15CM	WP25PM	WP35CM	WP40PM	TT125	THM
SNMT1205AZR31	4	12,70	12,70	5,56	1,54	0,16	●	○	○	○	○	○	○	○	○	○

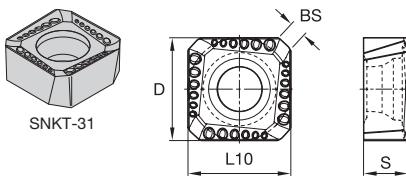

● first choice
○ alternate choice

P	●	●	●	●	●	●	●	●	●	●
M	○	○	○	○	○	○	○	○	○	○
K	○	○	○	○	○	○	○	○	○	○
N	○	○	○	○	○	○	○	○	○	○
S	●	○	○	○	○	○	○	○	○	○
H	○	○	○	○	○	○	○	○	○	○

■ SNKT-31

catalogue number	cutting edges	D	L10	S	BS	hm	TN6525	TN6540	TN7525	TN7535	WK15CM	WP40PM	TT125	THM
SNKT1205AZR31	4	12,70	12,70	5,56	1,54	0,16	○	○	○	○	○	○	○	○

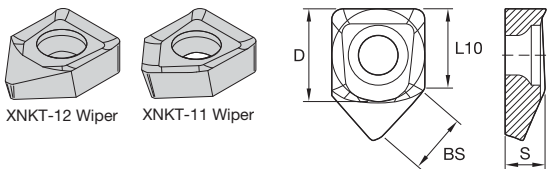

● first choice
○ alternate choice

P	●	●	●	●	●	●	●	●	●	●
M	○	○	○	○	○	○	○	○	○	○
K	○	○	○	○	○	○	○	○	○	○
N	○	○	○	○	○	○	○	○	○	○
S	●	○	○	○	○	○	○	○	○	○
H	○	○	○	○	○	○	○	○	○	○

■ XNKT-12 Wiper

catalogue number	cutting edges	D	L10	S	BS	hm	TN6540	TN7525	TN7535	WK15CM	WP40PM	TT125	THM
XNKT1205AZTR12	1	12,70	12,70	5,15	8,00	0,04	○	○	○	○	○	○	○

■ XNKT-11 Wiper

catalogue number	cutting edges	D	L10	S	BS	hm	TN6540	TN7525	TN7535	WK15CM	WP40PM	TT125	THM
XNKT1205AZER11	1	12,70	12,70	5,15	8,00	0,04	○	○	○	○	○	○	○

■ Recommended Starting Speeds [m/min]

Face Mills

Material Group		TN6525			TN6540			TN7525			TN7535		
P	1	410	320	280	360	280	240	410	310	280	545	475	445
	2	320	250	215	250	190	170	310	250	215	335	305	275
	3	280	215	185	215	170	140	280	215	185	305	275	245
	4	235	170	145	180	130	110	235	170	145	230	210	190
	5	310	235	200	240	180	150	310	235	200	310	275	250
	6	205	160	130	160	120	100	205	160	130	190	160	130
M	1	190	120	80	130	80	60	245	220	185	245	220	185
	2	120	80	50	80	50	40	220	190	170	220	190	170
	3	125	80	55	85	50	40	175	155	140	175	155	140
K	1	275	245	220	220	205	180	380	280	240	355	320	290
	2	215	190	180	175	155	140	325	240	200	280	250	230
	3	180	160	145	155	145	125	240	200	170	235	210	190
N	1	-	-	-	-	-	-	-	-	-	-	-	-
	2	-	-	-	-	-	-	-	-	-	-	-	-
	3	-	-	-	-	-	-	-	-	-	-	-	-
S	1	-	-	-	50	35	30	-	-	-	-	-	-
	2	-	-	-	25	20	10	-	-	-	-	-	-
	3	-	-	-	70	40	30	-	-	-	-	-	-
	4	-	-	-	60	30	25	-	-	-	-	-	-
H	1	-	-	-	-	-	-	-	-	-	-	-	-
	2	-	-	-	-	-	-	-	-	-	-	-	-
	3	-	-	-	-	-	-	-	-	-	-	-	-

(continued)

(Recommended Starting Speeds [m/min] – continued)

Material Group		WK15CM			WP40PM			TTI25			THM		
P	1	-	-	-	355	310	295	430	360	300	-	-	-
	2	-	-	-	300	260	215	310	250	215	-	-	-
	3	-	-	-	275	235	190	310	250	215	-	-	-
	4	-	-	-	245	205	160	265	215	180	-	-	-
	5	-	-	-	205	185	160	320	235	200	-	-	-
	6	-	-	-	180	140	110	145	110	90	-	-	-
M	1	-	-	-	235	205	185	480	310	215	-	-	-
	2	-	-	-	210	180	150	325	205	145	-	-	-
	3	-	-	-	155	140	110	320	210	145	-	-	-
K	1	505	460	410	-	-	-	220	185	155	145	110	90
	2	400	355	330	-	-	-	180	145	125	150	120	85
	3	335	300	275	-	-	-	145	125	100	155	115	70
N	1	-	-	-	-	-	-	-	-	-	1080	720	600
	2	-	-	-	-	-	-	-	-	-	820	560	460
	3	-	-	-	-	-	-	-	-	-	540	335	240
S	1	-	-	-	50	40	35	-	-	-	-	-	-
	2	-	-	-	50	40	35	-	-	-	-	-	-
	3	-	-	-	60	50	35	-	-	-	-	-	-
	4	-	-	-	80	60	40	-	-	-	-	-	-
H	1	-	-	-	-	-	-	-	-	-	-	-	-
	2	-	-	-	-	-	-	-	-	-	-	-	-
	3	-	-	-	-	-	-	-	-	-	-	-	-

NOTE: FIRST choice starting speeds are in **bold** type.
As the average chip thickness increases, the speed should be decreased.

Face Mills

Recommended Starting Feeds

■ Recommended Starting Feeds [mm]

Light Machining	General Purpose	Heavy Machining
-----------------	-----------------	-----------------

Insert Geometry	Programmed Feed per Tooth (fz) as a % of Radial Depth of Cut (ae)															Insert Geometry
	5%			10%			20%			30%			40-100%			
...20	0,17	0,66	1,19	0,12	0,47	0,86	0,09	0,35	0,64	0,08	0,31	0,56	0,07	0,28	0,51	...20
...21	0,24	0,74	1,25	0,18	0,53	0,89	0,13	0,40	0,66	0,12	0,35	0,58	0,11	0,32	0,53	...21
...31	0,26	0,76	1,28	0,19	0,55	0,91	0,14	0,41	0,68	0,12	0,36	0,59	0,11	0,33	0,54	...31

NOTE: Use "Light Machining" value as starting feed rate.

Face Mills • M660 Series

Shell Mills • SN1505..



Face Mills

- Four cutting edges.
- Strong tool body design.
- Thick inserts for reliability.

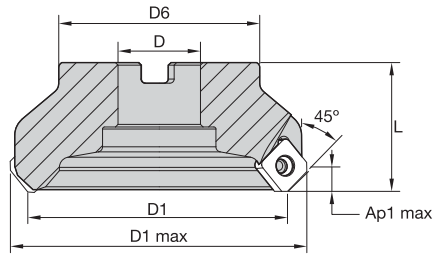
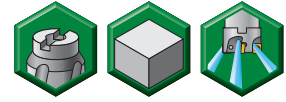

■ Shell Mills

order number	catalogue number	D1	D1 max	D	D6	L	Ap1 max	Z	max RPM	coolant supply	kg
2003593	12396215000	100	116,9	32	78	50	8,0	7	8900	No	1,60

■ Spare Parts



insert
screw



Nm



Torx
driver

D1	100	12148007200	3,5	12148007500
----	-----	-------------	-----	-------------

■ Insert Selection Guide

Material Group	Light Machining		General Purpose		Heavy Machining	
	Geometry	Grade	Geometry	Grade	Geometry	Grade
P1-P2	...31	WP40PM	...31	WP40PM	...31	WP40PM
P3-P4	...31	WP25PM	...31	WP35CM	...31	WP35CM
P5-P6	...31	WP25PM	...31	WP35CM	...31	WP35CM
M1-M2	...31	WP25PM	...31	WP25PM	...31	WP25PM
M3	...31	WP35CM	...31	WP35CM	...31	WP35CM
K1-K2	...31	WK15CM	...31	WK15CM	...31	WK15CM
K3	...31	WK15CM	...31	WK35CM	...31	WK15CM
N1-N2	-	-	-	-	-	-
N3	-	-	-	-	-	-
S1-S2	...31	WP25PM	...31	WP25PM	...31	WP25PM
S3	-	-	-	-	-	-
S4	...31	WP40PM	...31	WP40PM	...31	WP40PM
H1	-	-	-	-	-	-

Inserts • SN1505..

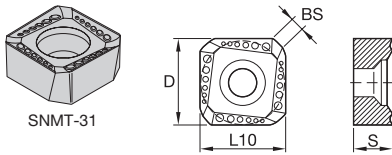

● first choice
○ alternate choice

P	●	●		
M	○	○		
K		○	●	
N				
S				
H				

■ SNMT-31

catalogue number	cutting edges	D	L10	S	BS	hm	TN7525	TN7535	WK15CM
SNMT1505AZR31	4	16	15,88	5,56	2,00	0,16	2020701	2020695	5427386

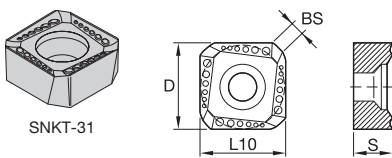

● first choice
○ alternate choice

P	●	●	●	●
M	○	○	○	○
K		○	○	○
N			●	
S			○	○
H			○	

■ SNKT-31

catalogue number	cutting edges	D	L10	S	BS	hm	TN7525	TN7535	WK15CM	WP25PM	WP35CM	WP40PM
SNKT1505AZR31	4	16	15,88	5,56	2,00	0,16	2020711	2020705	5427385	5895538	5895539	5895540

■ Recommended Starting Speeds [m/min]

Face Mills

Material Group		TN6525			TN7525			TN7535			WK15CM			WP25PM			WP35CM			WP40PM		
P	1	410	320	280	410	310	280	545	475	445	-	-	-	395	340	325	545	475	445	355	310	295
	2	320	250	215	310	250	215	335	305	275	-	-	-	330	290	240	335	305	275	300	260	215
	3	280	215	185	280	215	185	305	275	245	-	-	-	305	260	210	305	275	245	275	235	190
	4	235	170	145	235	170	145	230	210	190	-	-	-	270	220	180	230	210	190	245	205	160
	5	310	235	200	310	235	200	310	275	250	-	-	-	220	205	180	310	275	250	205	185	160
	6	205	160	130	205	160	130	190	160	130	-	-	-	200	150	120	190	160	130	180	140	110
M	1	190	120	80	245	220	185	245	220	185	-	-	-	245	215	200	245	220	185	235	205	185
	2	120	80	50	220	190	170	220	190	170	-	-	-	220	190	155	220	190	170	210	180	150
	3	125	80	55	175	155	140	175	155	140	-	-	-	170	145	115	175	155	140	155	140	110
K	1	275	245	220	380	280	240	355	320	290	505	460	410	275	245	220	355	320	290	-	-	-
	2	215	190	180	325	240	200	280	250	230	400	355	330	215	190	180	280	250	230	-	-	-
	3	180	160	145	240	200	170	235	210	190	335	300	275	180	160	145	235	210	190	-	-	-
N	1	-	-	-	-	-	-	-	-	-	-	-	-	-	-	-	-	-	-	-	-	-
	2	-	-	-	-	-	-	-	-	-	-	-	-	-	-	-	-	-	-	-	-	-
	3	-	-	-	-	-	-	-	-	-	-	-	-	-	-	-	-	-	-	-	-	-
S	1	-	-	-	-	-	-	-	-	-	-	-	-	50	40	30	-	-	-	50	40	35
	2	-	-	-	-	-	-	-	-	-	-	-	-	50	40	30	-	-	-	50	40	35
	3	-	-	-	-	-	-	-	-	-	-	-	-	60	50	30	-	-	-	60	50	35
	4	-	-	-	-	-	-	-	-	-	-	-	-	85	60	40	80	60	40	80	60	40
H	1	-	-	-	-	-	-	-	-	-	-	-	-	-	-	-	-	-	-	-	-	-
	2	-	-	-	-	-	-	-	-	-	-	-	-	-	-	-	-	-	-	-	-	-
	3	-	-	-	-	-	-	-	-	-	-	-	-	-	-	-	-	-	-	-	-	-

NOTE: FIRST choice starting speeds are in **bold** type.
As the average chip thickness increases, the speed should be decreased.

Recommended Starting Feeds

■ Recommended Starting Feeds [mm]

Light Machining	General Purpose	Heavy Machining
-----------------	-----------------	-----------------

Insert Geometry	Programmed Feed per Tooth (fz) as a % of Radial Depth of Cut (ae)															Insert Geometry
	5%			10%			20%			30%			40-100%			
...21	0,24	0,74	1,25	0,18	0,53	0,89	0,13	0,40	0,66	0,12	0,35	0,58	0,11	0,32	0,53	...21
...31	0,33	0,84	1,35	0,24	0,60	0,97	0,18	0,45	0,72	0,16	0,39	0,63	0,14	0,36	0,57	...31

NOTE: Use "Light Machining" value as starting feed rate.

Making the Grade in Innovative Metalcutting Technology



EXTREME **CHALLENGES.**
EXTREME **RESULTS.**

Victory™ Milling Grades

Our new Victory milling grades are designed to deliver higher productivity, longer tool life, and increased application versatility.

- WP40PM™ — New best-in-class Victory milling grade for machining steel materials in ISO material group P40 in rough milling applications.
- WK15CM™ — New milling grade for cast irons for higher tool life and increased productivity.
- WS30PM™ — A new high-performance milling grade for machining titanium and stainless steels.

To learn more about the benefits of the new **WIDIA™ Victory milling grades**, contact your local distributor.

WIDIA 



Indexable Milling • 90° Shoulder Mills

VSM11 • Versatile – Single-Sided 90° Shoulder Mill Platform	G2–G16
VSM17 • Versatile – Single-Sided 90° Shoulder Mill Platform	G18–G29
VSM490-15 • Double-Sided Shoulder Milling Platform with Four Cutting Edges	G30–G40
M680 • 90° Shoulder Mill Platform	G42–G51
M690 • Square Insert Shoulder Mill Platform	G52–G61



WIDIA™ Victory™ Shoulder Mill 11™ •
VSM11™

VSM11



Victory™ Shoulder Mill 11™ is a high-performance, versatile, robust, 90° square shoulder milling platform. VSM11 is designed for versatility, low horsepower consumption, and easy cutting action. Cutters can be used for profiling, face milling, slotting, ramping, helical interpolation, circular interpolation, and other milling applications. Inserts are specially designed with innovative geometries and features like variable rake angles, negative T-land, small hone, and the latest Victory grades enhancing tool performance and versatility.

Take advantage of the high-performance, advanced carbide substrates, coatings, and surface treatment technologies of the available 6 Victory grades, 5 geometries, and broad range of cutter body product portfolio. This platform works with multiple material types and applications.

- State-of-the-art step down capability.
- Screw-on, end mill, and shell mill cutters with effective internal coolant supply.

Features

- Insert geometries and grades for all workpiece materials.
- Insert corner radius from 0,4–3,1mm (.016–.122").

Benefits

- Achieve 90° wall finish.
- Longer tool life.
- Latest WIDIA Victory milling grades for all workpiece materials.
- Soft cutting action, reduced cycle times, and low horsepower consumption.
- Stability and reliability.

Multiple corner nose radii available.

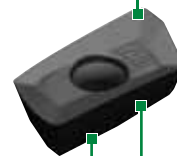

Optimised cutting edge and positive rake face for reduced cutting forces and softer cutting action.

Innovative cutting geometry provides superior wall and surface finish.

90° Shoulder Mills

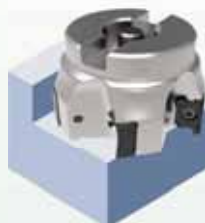

VSM11™

Max depth of cut: 11,7mm

Lead angle: 90°

Indexes per insert: 2

Diameter: 16–125mm

Pages: G4–G16

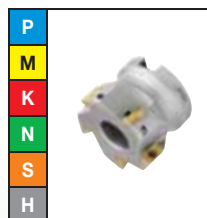

■ Insert Offering

XDCT-ML

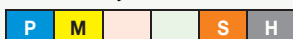

Light to medium machining.
First choice for stainless steel
and titanium.
Periphery ground.

XDPT-MM



Medium to heavy machining.
First choice for general purpose.
Precision pressed to size.

XDPT-MH



First choice for heavy-duty machining.
Steel and cast iron materials.
Precision pressed to size.

XDCT-ALP

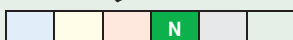
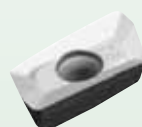

Roughing and finishing
of aluminium alloys.
High precision.
Periphery ground.

XDCW-PCD

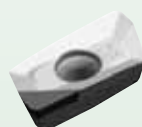

Roughing and finishing
of aluminium alloys.
Abrasive non-ferrous materials.
High precision.
Periphery ground.

- True 90° capability.
- Increased ramping capability.
- Superior wall and surface finish.
- Effective internal coolant feature, precisely reaching the cutting edge.

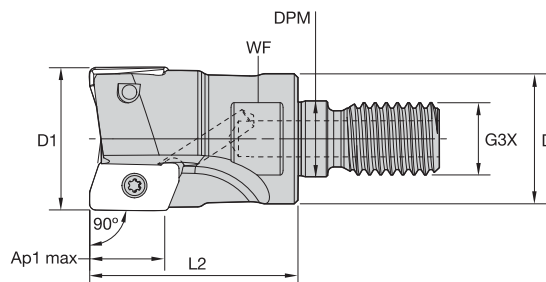
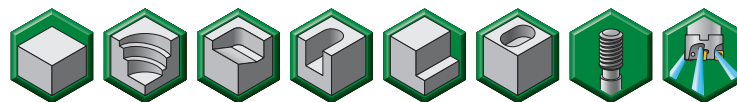

■ Screw-On End Mills

order number	catalogue number	D1	D	DPM	G3X	L2	WF	Ap1 max	Z	max ramp angle	coolant supply	max RPM	kg
5417011	VSM11D016Z02M08XD11	16	13	8,5	M8	25	10	11,5	2	10.0°	Yes	41400	0,02
5417013	VSM11D020Z03M10XD11	20	18	10,5	M10	28	15	11,6	3	7.8°	Yes	35100	0,05
5417015	VSM11D025Z04M12XD11	25	21	12,5	M12	32	17	11,5	4	5.3°	Yes	30200	0,08
5417017	VSM11D032Z04M16XD11	32	29	17,0	M16	40	24	11,4	4	3.6°	Yes	25800	0,18
5417019	VSM11D040Z06M16XD11	40	29	17,0	M16	40	24	11,4	6	2.6°	Yes	22600	0,24

■ Spare Parts



insert screw

192.432



Nm

1,0



wrench

170.028

NOTE: Standard milling cutters will accept insert nose radii up to 1,6mm without modification.
For tool body modification instructions, see page G16.

- True 90° capability.
- Increased ramping capability.
- Superior wall and surface finish.
- Effective internal coolant feature, precisely reaching the cutting edge.

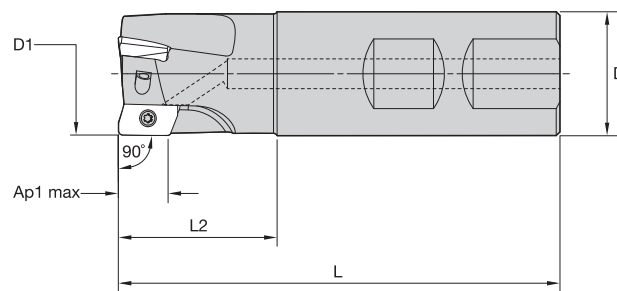
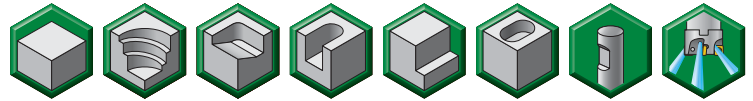

Shoulder Mills

■ **Weldon Shanks**

order number	catalogue number	D1	D	L	L2	Ap1 max	Z	max ramp angle	coolant supply	max RPM	kg
5416454	VSM11D012Z01B16XD11	12	16	70	21	11,7	1	3.7°	Yes	53100	0,08
5416455	VSM11D016Z02B16XD11	16	16	70	21	11,5	2	10.0°	Yes	41400	0,09
5416457	VSM11D020Z02B20XD11	20	20	81	30	11,6	2	7.8°	Yes	35100	0,15
5416458	VSM11D020Z03B20XD11	20	20	81	30	11,6	3	7.8°	Yes	35100	0,16
5416459	VSM11D025Z03B25XD11	25	25	88	31	11,5	3	5.3°	Yes	30200	0,27
5416480	VSM11D025Z04B25XD11	25	25	88	31	11,5	4	5.3°	Yes	30200	0,28
5416481	VSM11D030Z04B25XD11	30	25	88	31	11,5	4	3.2°	Yes	26900	0,30
5416482	VSM11D032Z04B32XD11	32	32	100	39	11,4	4	3.6°	Yes	25800	0,51
5416483	VSM11D032Z05B32XD11	32	32	100	39	11,4	5	3.6°	Yes	25800	0,52

■ **Spare Parts**



insert screw

192.432



Nm

1,0



wrench

170.028

NOTE: Standard milling cutters will accept insert nose radii up to 1,6mm without modification.
For tool body modification instructions, see page G16.

- True 90° capability.
- Increased ramping capability.
- Superior wall and surface finish.
- Effective internal coolant feature, precisely reaching the cutting edge.

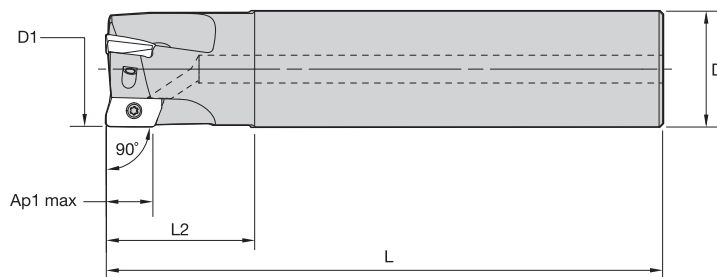
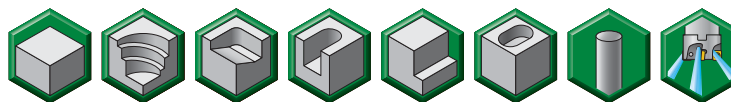

Shoulder Mills

■ Cylindrical End Mills

order number	catalogue number	D1	D	L	L2	Ap1 max	Z	max ramp angle	coolant supply	max RPM	kg
5416632	VSM11D012Z01A16XD11L100	12	16	100	25	11,7	1	3.7°	Yes	53100	0,13
5416633	VSM11D016Z02A16XD11L100	16	16	100	31	11,5	2	10.0°	Yes	41400	0,12
5416634	VSM11D020Z02A20XD11L110	20	20	110	31	11,6	2	7.8°	Yes	35100	0,22
5416635	VSM11D020Z03A20XD11L110	20	20	110	31	11,6	3	7.8°	Yes	35100	0,23
5416636	VSM11D025Z03A25XD11L120	25	25	120	33	11,5	3	5.3°	Yes	30200	0,39
5416637	VSM11D025Z04A25XD11L120	25	25	120	33	11,5	4	5.3°	Yes	30200	0,40
5416638	VSM11D032Z03A32XD11L130	32	32	130	41	11,4	3	3.6°	Yes	25800	0,70
5416639	VSM11D032Z05A32XD11L130	32	32	130	41	11,4	5	3.6°	Yes	25800	0,71

■ Spare Parts



insert screw

192.432



Nm

1,0



wrench

170.028

NOTE: Standard milling cutters will accept insert nose radii up to 1,6mm without modification.
For tool body modification instructions, see page G16.

- True 90° capability.
- Increased ramping capability.
- Superior wall and surface finish.
- Effective internal coolant feature, precisely reaching the cutting edge.

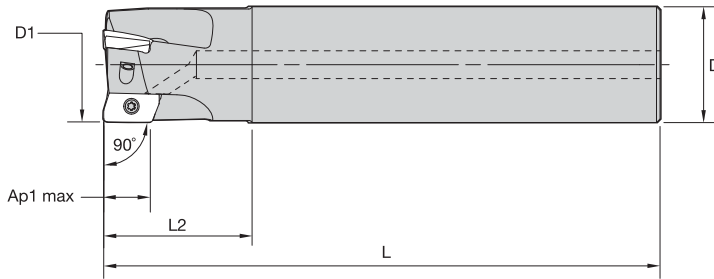
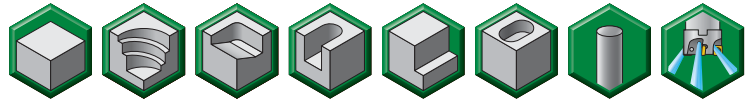

Shoulder Mills

■ Cylindrical End Mills • Long Shanks

order number	catalogue number	D1	D	L	L2	Ap1 max	Z	max ramp angle	coolant supply	max RPM	kg
5416700	VSM11D016Z02A16XD11L170	16	16	170	25	11,5	2	10.0°	Yes	41400	0,23
5416701	VSM11D018Z02A16XD11L170	18	16	170	25	11,6	2	9.7°	Yes	37900	0,23
5416702	VSM11D020Z02A20XD11L170	20	20	170	41	11,6	2	7.8°	Yes	35100	0,35
5416703	VSM11D020Z03A20XD11L170	20	20	170	41	11,6	3	7.8°	Yes	35100	0,36
5416704	VSM11D022Z03A20XD11L170	22	20	170	30	11,5	3	6.6°	Yes	32900	0,37
5416705	VSM11D025Z03A25XD11L210	25	25	210	50	11,5	3	5.3°	Yes	30200	0,70
5416706	VSM11D025Z04A25XD11L210	25	25	210	50	11,5	4	5.3°	Yes	30200	0,72
5416707	VSM11D032Z03A32XD11L250	32	32	250	65	11,4	3	3.6°	Yes	25800	1,39

■ Spare Parts



insert screw

192.432



Nm

1,0



wrench

170.028

NOTE: Standard milling cutters will accept insert nose radii up to 1,6mm without modification.
For tool body modification instructions, see page G16.

- True 90° capability.
- Increased ramping capability.
- Superior wall and surface finish.
- Effective internal coolant feature, precisely reaching the cutting edge.

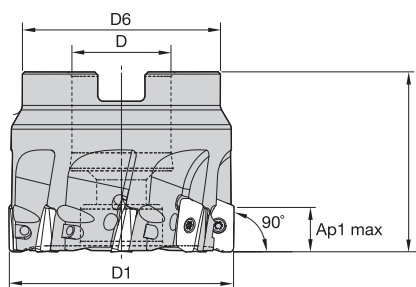
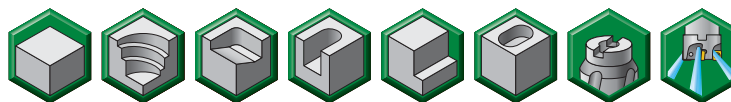

Shoulder Mills

■ Shell Mills

order number	catalogue number	D1	D	D6	L	Ap1 max	Z	max ramp angle	coolant supply	max RPM	kg
5416316	VSM11D040Z04S016XD11	40	16	37	40	11,4	4	2.6°	Yes	22600	0,22
5416317	VSM11D040Z06S016XD11	40	16	37	40	11,4	6	2.6°	Yes	22600	0,22
5416318	VSM11D050Z05S022XD11	50	22	44	40	11,3	5	1.9°	Yes	19900	0,33
5416319	VSM11D050Z08S022XD11	50	22	44	40	11,3	8	1.9°	Yes	19900	0,33
5416340	VSM11D063Z06S022XD11	63	22	44	40	11,3	6	1.5°	Yes	17500	0,50
5416341	VSM11D063Z09S022XD11	63	22	44	40	11,3	9	1.5°	Yes	17500	0,52
5416342	VSM11D080Z08S027XD11	80	27	60	50	11,3	8	1.1°	Yes	15300	1,14
5416345	VSM11D100Z09S032XD11	100	32	80	50	11,3	9	0.9°	Yes	13600	1,79
5416347	VSM11D125Z011S040XD11	125	40	80	63	11,3	11	0.7°	Yes	12100	3,01

■ Spare Parts



D1	insert screw	Nm	wrench	socket-head cap screw	socket-head cap screw with coolant groove	coolant lock screw assembly
40,0	192.432	1,0	170.028	MS1294	MS1294CG	-
50,0	192.432	1,0	170.028	12146120500	MS1234CG	-
63,0	192.432	1,0	170.028	12146120500	MS1234CG	-
80,0	192.432	1,0	170.028	125.230	MS2038CG	-
100,0	192.432	1,0	170.028	-	-	MS2195C
125,0	192.432	1,0	170.028	-	-	MS2187C

NOTE: Socket-head cap screw and coolant lock screw assembly must be ordered separately.

■ **Insert Selection Guide**

Material Group	Light Machining		General Purpose		Heavy Machining	
	Geometry	Grade	Geometry	Grade	Geometry	Grade
P1-P2	.E..ML	WP40PM	.E..MM	WP40PM	.S..MH	WP40PM
P3-P4	.E..ML	WP35CM	.E..MM	WP35CM	.S..MH	WP35CM
P5-P6	.E..MM	WP25PM	.S..MH	WP35CM	.S..MH	WP35CM
M1-M2	.E..ML	WU35PM	.E..MM	WU35PM	.S..MH	WU35PM
M3	.E..ML	WU35PM	.E..MM	WU35PM	.S..MH	WU35PM
K1-K2	.E..ML	WK15CM	.E..MM	WK15CM	.S..MH	WK15CM
K3	.E..ML	WP25PM	.E..MM	WP25PM	.S..MH	WP25PM
N1-N2	.F..ALP	WN25PM	.F..ALP	WN25PM	.E..ML	WP25PM
N3	.F..ALP	WN25PM	.F..ALP	WN25PM	.E..ML	WP25PM
S1-S2	.E..ML	WP25PM	.E..MM	WU35PM	.S..MH	WU35PM
S3	.E..ML	WP25PM	.E..MM	WU35PM	.S..MH	WU35PM
S4	.E..MM	WU35PM	.S..MH	WU35PM	-	-
H1	.E..MM	WP25PM	.E..MM	WP25PM	-	-

Shoulder Mills

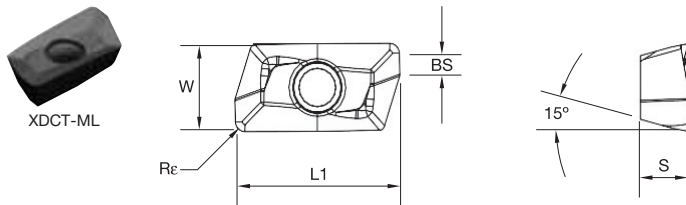

- -ML is a light- to medium-machining geometry and is the first choice for stainless steel and titanium materials.

- first choice
- alternate choice



	P	M	K	N	S	H
P	●					
M		●				
K			●			
N				●		
S					●	
H						●

■ **XDCT-ML**

catalogue number	cutting edges	L1	BS	S	W	Rε	hm	WDN10U	WK15CM	WN25PM	WP25PM	WP35CM	WP40PM	WS30PM	WU35PM
XDCT110404PDERML	2	13,43	2,09	4,00	6,90	0,40	0,04				5536671	5536670	5642230		
XDCT110408PDERML	2	13,44	1,69	4,00	6,90	0,80	0,04		5415549		5415548	5415547	5545065	5517826	5415546

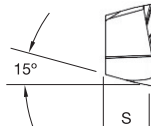
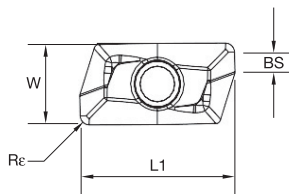
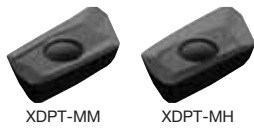

- first choice
- alternate choice

• -MM is a medium- to heavy-machining geometry and is the first choice for general purpose and universal applications.

■ XDPT-MM

catalogue number	cutting edges	L1	BS	S	W	Re	hm	WDN10U	WK15CM	WN25PM	WP25PM	WP35CM	WP40PM	WS30PM	WU35PM
XDPT110404PDSRMM	2	13,43	2,06	4,00	6,90	0,40	0,06	●	●	○	○	○	○	○	○
XDPT110408PDSRMM	2	13,44	1,68	4,00	6,90	0,79	0,06	●	●	○	○	○	○	○	○
XDPT110412PDSRMM	2	13,44	1,29	4,00	6,90	1,20	0,06	●	●	○	○	○	○	○	○
XDPT110416PDSRMM	2	13,51	0,85	4,13	6,95	1,60	0,06	●	●	○	○	○	○	○	○
XDPT110420PDSRMM	2	13,51	0,45	4,13	6,95	2,00	0,06	●	●	○	○	○	○	○	○
XDPT110424PDSRMM	2	13,37	—	4,01	6,94	2,40	0,06	●	●	○	○	○	○	○	○
XDPT110431PDSRMM	2	12,91	—	4,00	6,89	3,10	0,06	●	●	○	○	○	○	○	○

• -MH is a heavy-duty machining geometry and is the first choice for steel and cast iron materials.

■ XDPT-MH

catalogue number	cutting edges	L1	BS	S	W	Re	hm	WDN10U	WK15CM	WN25PM	WP25PM	WP35CM	WP40PM	WS30PM	WU35PM
XDPT110408PDSRMH	2	13,44	1,68	4,00	6,90	0,79	0,13	●	●	○	○	○	○	○	○
XDPT110412PDSRMH	2	13,44	1,29	4,00	6,90	1,20	0,13	●	●	○	○	○	○	○	○
XDPT110416PDSRMH	2	13,44	0,90	4,00	6,90	1,59	0,13	●	●	○	○	○	○	○	○



P	●	○	○	○	○	○	○
M	●	○	○	○	○	○	○
K	●	○	○	○	○	○	○
N	●	○	○	○	○	○	○
S	●	○	○	○	○	○	○
H	●	○	○	○	○	○	○

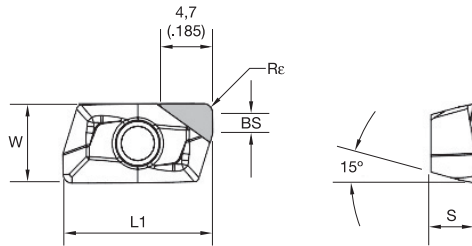

P	●
M	○
K	○
N	●
S	○
H	○

- first choice
- alternate choice

- PCD is the first choice for roughing and finishing of abrasive non-ferrous materials and aluminium alloys.

XDCW-PCD

catalogue number	cutting edges	L1	BS	S	W	Re	hm	WDN10U
XDCW110404PDFRPCD	1	13,43	2,10	4,00	6,90	0,40	0,02	5415420
XDCW110408PDFRPCD	1	13,44	1,70	4,00	6,90	0,80	0,02	5415421

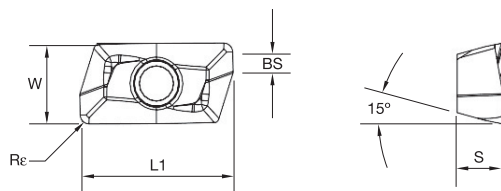

P	●
M	○
K	○
N	●
S	○
H	○

- first choice
- alternate choice

- ALP is the first choice for roughing and finishing of aluminium alloys.

XDCT-ALP

catalogue number	cutting edges	L1	BS	S	W	Re	hm	WN10HM	WN25PM
XDCT110404PDFRALP	2	13,43	2,09	4,00	6,90	0,40	0,02	5933940	5417054
XDCT110408PDFRALP	2	13,44	1,69	4,00	6,90	0,80	0,02	5936171	5417053
XDCT110412PDFRALP	2	13,44	1,29	4,00	6,90	1,20	0,02	6055634	6055635
XDCT110416PDFRALP	2	13,44	0,88	4,00	6,89	1,60	0,02	6055598	6055599
XDCT110424PDFRALP	2	13,44	0,16	4,00	6,88	2,40	0,02	6055600	6055631
XDCT110432PDFRALP	2	12,86	—	4,00	6,89	3,20	0,02	6055632	6055633

■ Recommended Starting Speeds [m/min]

Shoulder Mills

Material Group		WP25PM			WU35PM			WP40PM			WK15CM		
P	1	330	285	270	260	230	215	300	260	250	-	-	-
	2	275	240	200	220	190	160	250	220	180	-	-	-
	3	255	215	175	200	170	140	230	200	160	-	-	-
	4	225	185	150	180	150	120	210	170	140	-	-	-
	5	185	170	150	150	135	120	170	160	140	-	-	-
	6	165	125	100	130	100	80	150	120	90	-	-	-
M	1	205	180	165	170	150	135	200	170	160	-	-	-
	2	185	160	130	155	130	110	180	150	130	-	-	-
	3	140	120	95	115	100	80	130	120	90	-	-	-
K	1	230	205	185	-	-	-	-	-	-	420	385	340
	2	180	160	150	-	-	-	-	-	-	335	295	275
	3	150	135	120	-	-	-	-	-	-	280	250	230
N	1-2	-	-	-	-	-	-	-	-	-	-	-	-
	3	-	-	-	-	-	-	-	-	-	-	-	-
S	1	40	35	25	35	30	25	40	40	30	-	-	-
	2	40	35	25	35	30	25	40	40	30	-	-	-
	3	50	40	25	45	35	25	50	40	30	-	-	-
	4	70	50	35	60	45	30	70	50	40	-	-	-
H	1	120	90	70	-	-	-	-	-	-	-	-	-

(continued)

(Recommended Starting Speeds [m/min] – continued)

Material Group		WS30PM			WP35CM			WN25PM			WDN10U		
P	1	-	-	-	455	395	370	-	-	-	-	-	-
	2	-	-	-	280	255	230	-	-	-	-	-	-
	3	-	-	-	255	230	205	-	-	-	-	-	-
	4	-	-	-	190	175	160	-	-	-	-	-	-
	5	-	-	-	260	230	210	-	-	-	-	-	-
	6	-	-	-	160	135	110	-	-	-	-	-	-
M	1	225	200	185	205	185	155	-	-	-	-	-	-
	2	205	180	145	185	160	140	-	-	-	-	-	-
	3	155	135	105	145	130	115	-	-	-	-	-	-
K	1	-	-	-	295	265	240	-	-	-	-	-	-
	2	-	-	-	235	210	190	-	-	-	-	-	-
	3	-	-	-	195	175	160	-	-	-	-	-	-
N	1-2	-	-	-	-	-	-	1075	945	875	2755	2450	2255
	3	-	-	-	-	-	-	945	875	760	2285	1670	1355
S	1	45	40	30	-	-	-	-	-	-	-	-	-
	2	45	40	30	-	-	-	-	-	-	-	-	-
	3	55	45	30	-	-	-	-	-	-	-	-	-
	4	85	60	40	66	50	33	-	-	-	-	-	-
H	1	-	-	-	-	-	-	-	-	-	-	-	-

NOTE: FIRST choice starting speeds are in **bold** type.
As the average chip thickness increases, the speed should be decreased.

Shoulder Mills

Recommended Starting Feeds

■ Recommended Starting Feeds [mm]

Light Machining	General Purpose	Heavy Machining
-----------------	-----------------	-----------------

Insert Geometry	Programmed Feed per Tooth (fz) as a % of Radial Depth of Cut (ae)															Insert Geometry
	10%			20%			30%			40%			50-100%			
.F.-PCD	0,08	0,17	0,23	0,06	0,13	0,18	0,06	0,11	0,15	0,05	0,10	0,14	0,05	0,10	0,14	.F.-PCD
.F..ALP	0,08	0,10	0,16	0,06	0,07	0,12	0,06	0,06	0,10	0,05	0,06	0,10	0,05	0,06	0,10	.F..ALP
.E..ML	0,09	0,18	0,30	0,07	0,14	0,23	0,06	0,12	0,20	0,05	0,11	0,19	0,05	0,11	0,18	.E..ML
.S..MM	0,17	0,20	0,34	0,13	0,15	0,25	0,11	0,13	0,22	0,10	0,12	0,21	0,10	0,12	0,20	.S..MM
.S..MH	0,17	0,25	0,40	0,13	0,19	0,30	0,11	0,17	0,26	0,10	0,15	0,24	0,10	0,15	0,24	.S..MH

NOTE: Use "Light Machining" values as starting feed rate.

Achieve True 90° Shoulder Milling with the New High-Performance WIDIA™ VSM11™ Starter Kits.

Victory™ Shoulder Mill 11™ Starter Kits

Order one of our starter kits and test the performance of our new VSM11 platform. The kits are set up to serve the majority of shoulder milling applications, delivered with a cutter body and the latest WIDIA Victory™ grades. Detailed order information can be found in the table below.



■ VSM11 Starter Kits • Metric

order number	catalogue number	diameter D1 (mm)	cutter body type	material group	content				
					cutter	qty	inserts	grade	Z (pocket seats)
5527101	VSM11KITWD016Z02WP40PM	16	Weldon	P	VSM11D016Z02B16XD11	10	XDPT110408PDSRMM	WP40PM	2
5527102	VSM11KITWD020Z03WP40PM	20	Weldon	P	VSM11D020Z03B20XD11	10	XDPT110408PDSRMM	WP40PM	3
5527106	VSM11KITS050Z05WP40PM	50	Shell	P	VSM11D050Z05S022XD11	10	XDPT110408PDSRMM	WP40PM	5
5719051	VSM11KITS040Z06WP40PM	40	Shell	P	VSM11D040Z06S016XD11	10	XDPT110408PDSRMM	WP40PM	6
5719052	VSM11KITCD016Z02WP40PM	16	Cylindrical	P	VSM11D016Z02A16XD11L100	10	XDPT110408PDSRMM	WP40PM	2
5719053	VSM11KITCD020Z03WP40PM	20	Cylindrical	P	VSM11D020Z03A20XD11L110	10	XDPT110408PDSRMM	WP40PM	3
5719054	VSM11KITCD025Z04WP40PM	25	Cylindrical	P	VSM11D025Z04A25XD11L120	10	XDPT110408PDSRMM	WP40PM	4
5719055	VSM11KITCD032Z03WP40PM	32	Cylindrical	P	VSM11D032Z03A32XD11L130	10	XDPT110408PDSRMM	WP40PM	3
5886219	VSM11KITCD025Z03L120WP40PM	25	Cylindrical	P	VSM11D025Z03A25XD11L120	10	XDPT110408PDSRMM	WP40PM	3
5886220*	VSM11KITCD025Z03L210WP40PM	25	Cylindrical	P	VSM11D025Z03A25XD11L210	10	XDPT110408PDSRMM	WP40PM	3
5886251*	VSM11KITCD032Z03L250WP40PM	32	Cylindrical	P	VSM11D032Z03A32XD11L250	10	XDPT110408PDSRMM	WP40PM	3

*Starter Kit to be delivered in regular WIDIA™ corrugated box.

■ Application Examples

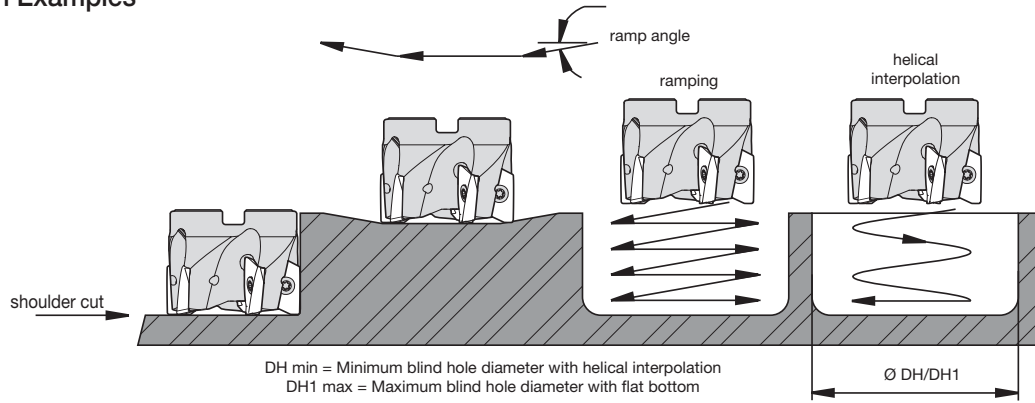

Shoulder Mills

order number	catalogue number	number of inserts	max RPM	max ramp angle to steel body interference	max flat-bottom hole diameter (DH1 max)	min hole diameter (DH min)
5417011	VSM11D016Z02M08XD11	2	41400	10.00°	32,00	19,00
5417013	VSM11D020Z03M10XD11	3	35100	7.80°	40,00	27,00
5417015	VSM11D025Z04M12XD11	4	30200	5.30°	50,00	37,00
5417017	VSM11D032Z04M16XD11	4	25800	3.60°	64,00	51,00
5417019	VSM11D040Z06M16XD11	6	22600	2.60°	80,00	67,00
5416454	VSM11D012Z01B16XD11	1	53100	3.70°	24,00	11,00
5416455	VSM11D016Z02B16XD11	2	41400	10.00°	32,00	19,00
5416457	VSM11D020Z02B20XD11	2	35100	7.80°	40,00	27,00
5416458	VSM11D020Z03B20XD11	3	35100	7.80°	40,00	27,00
5416459	VSM11D025Z03B25XD11	3	30200	5.30°	50,00	37,00
5416480	VSM11D025Z04B25XD11	4	30200	5.30°	50,00	37,00
5416481	VSM11D030Z04B25XD11	4	26900	3.20°	60,00	47,00
5416482	VSM11D032Z04B32XD11	4	25800	3.60°	64,00	51,00
5416483	VSM11D032Z05B32XD11	5	25800	3.60°	64,00	51,00
5416632	VSM11D012Z01A16XD11L100	1	53100	4.00°	24,00	11,00
5416633	VSM11D016Z02A16XD11L100	2	41400	10.00°	32,00	19,00
5416634	VSM11D020Z02A20XD11L110	2	35100	8.00°	40,00	27,00
5416635	VSM11D020Z03A20XD11L110	3	35100	8.00°	40,00	27,00
5416637	VSM11D025Z04A25XD11L120	4	30200	5.00°	50,00	37,00
5416636	VSM11D025Z03A25XD11L120	3	30200	5.00°	50,00	37,00
5416638	VSM11D032Z03A32XD11L130	3	25800	4.00°	64,00	51,00
5416639	VSM11D032Z05A32XD11L130	5	25800	4.00°	64,00	51,00
5416700	VSM11D016Z02A16XD11L170	2	41400	10.00°	32,00	19,00
5416701	VSM11D018Z02A16XD11L170	2	37900	10.00°	36,00	23,00
5416703	VSM11D020Z03A20XD11L170	3	35100	8.00°	40,00	27,00
5416702	VSM11D020Z02A20XD11L170	2	35100	8.00°	40,00	27,00
5416704	VSM11D022Z03A20XD11L170	3	32900	7.00°	44,00	31,00
5416705	VSM11D025Z03A25XD11L210	3	30200	5.00°	50,00	37,00
5416706	VSM11D025Z04A25XD11L210	4	30200	5.00°	50,00	37,00
5416707	VSM11D032Z03A32XD11L250	3	25800	4.00°	64,00	51,00
5416316	VSM11D040Z04S016XD11	4	22600	3.00°	80,00	67,00
5416317	VSM11D040Z06S016XD11	6	22600	3.00°	80,00	67,00
5416318	VSM11D050Z05S022XD11	5	19900	2.00°	100,00	87,00
5416319	VSM11D050Z08S022XD11	8	19900	2.00°	100,00	87,00
5416340	VSM11D063Z06S022XD11	6	17500	2.00°	126,00	113,00
5416341	VSM11D063Z09S022XD11	9	17500	2.00°	126,00	113,00
5416342	VSM11D080Z08S027XD11	8	15300	1.00°	160,00	147,00
5416345	VSM11D100Z09S032XD11	9	13600	0.90°	200,00	187,00
5416347	VSM11D125Z011S040XD11	11	12100	0.70°	250,00	237,00

NOTE: For DH1 max, subtract the insert corner radius from the max hole diameter.

Shoulder Mills

**Modification Instructions for Use of Larger Radii Inserts
(Shoulder Mills and Helical Mills)**

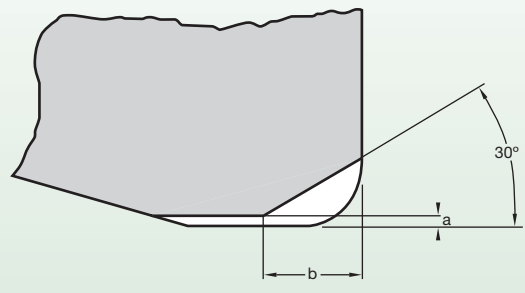

insert corner radius	material to remove	
	a	b
3,1mm	0,2mm	1,8mm



Engineered to Achieve Superior Surface Quality



EXTREME **CHALLENGES.**
EXTREME **RESULTS.**

Victory™ Shoulder Mill Series

The Victory Shoulder Mill (VSM) family of tools provides a comprehensive solution for your most challenging shoulder milling applications. The unique design of the VSM11™, VSM17™, and VSM490™ is capable of producing a true 90° wall in multiple material types. When combined with the latest WIDIA™ Victory™ grades, VSM from WIDIA provides superior performance at high speeds.

- Innovative cutting geometry provides superior wall and surface finish.
- State-of-the-art step-down capability.
- Real soft cutting action results in lower cutting forces and low machine power consumption.
- VSM11 and VSM17 offer aggressive ramping capabilities.
- VSM490 provides outstanding step-down capabilities in applications that require multiple passes.

To learn more about the benefits of the WIDIA™ Victory Shoulder Mill Series, contact your local distributor.

WIDIA 

WIDIA™ Victory™ Shoulder Mill 17™ •
VSM17™



VSM17

WIDIA Victory Shoulder Mill 17 is a high-performance, versatile, robust, 90° square shoulder milling platform. VSM17 is designed for versatility, low horsepower consumption, and easy cutting action. Cutters can be used for shoulder milling, profiling, face milling, slotting, ramping, helical interpolation, and circular interpolation milling applications. Inserts are specially designed with innovative geometries and features like variable rake angles, negative T-land, small hone, and the latest Victory grades enhancing tool performance and versatility.

Take advantage of the high-performance, advanced carbide substrates, coatings, and surface treatment technologies of the available 7 Victory grades, 4 geometries, and a broad-range cutter body product portfolio. This platform works with multiple material types and applications.

- Up to 16,33mm (.65") depth-of-cut capabilities.
- State-of-the-art step down capability.
- Screw-on, end mill, and shell mill cutters with effective internal coolant supply.

Features

- Insert geometries and grades for all workpiece materials.
- Insert corner radius from 0,4–4mm (.015–.157").
- Max axial depth of cut 16,3mm (0.65").

Benefits

- Achieve true 90° wall finish.
- High performance and longer tool life.
- Latest WIDIA Victory milling grades for all workpiece materials.
- High positive geometry, soft cutting action, reduced cycle times, and low horsepower consumption.
- Stability and reliability.

Multiple corner nose radii available.

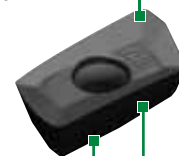

Optimised cutting edge and positive rake face for reduced cutting forces and softer cutting action.

Innovative cutting geometry provides superior wall and surface finish.

90° Shoulder Mills

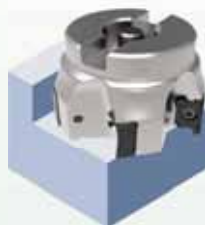

VSM17™

Max depth of cut: 16,33mm

Lead angle: 90°
Indexes per insert: 2
Diameter: 25–160mm

Pages: G20–G29

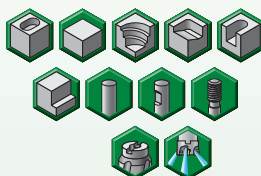

■ Insert Offering

XDPT-MM



Medium to heavy machining.
First choice for general purpose.
Precision pressed to size.

XDPT-MH



First choice for heavy-duty machining.
Steel and cast iron materials.
Precision pressed to size.

XDCT-ALP

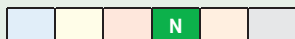

Roughing and finishing
of aluminium alloys.
High precision.
Periphery ground.

XDCT-ML

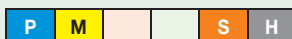

Light to medium machining.
First choice for stainless steel
and titanium.
Periphery ground.

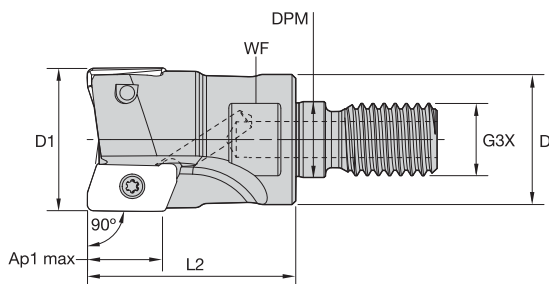
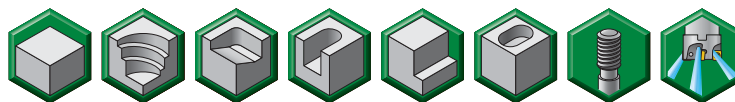

■ Screw-On End Mills

order number	catalogue number	D1	D	DPM	G3X	L2	WF	Ap1 max	Z	max ramp angle	coolant supply	max RPM	kg
5988091	VSM17D025Z02M12XD17	25	21	12,5	M12	35	17	16,3	2	8.8	Yes	41800	0,08
5988132	VSM17D32Z02M016XD17	32	29	17,0	M16	40	24	16,3	2	5.7	Yes	34700	0,18
5988092	VSM17D032Z03M16XD17	32	29	17,0	M16	40	24	16,3	3	5.7	Yes	34700	0,17
5988131	VSM17D40Z03M016XD17	40	29	17,0	M16	40	24	16,2	3	4.0	Yes	29800	0,20
5988093	VSM17D040Z04M16XD17	40	29	17,0	M16	40	24	16,2	4	4.0	Yes	29800	0,20

■ Spare Parts



insert screw

191.725



Nm

3,5



wrench

170.025

NOTE: Standard milling cutters will accept insert nose radii up to 1,6mm without modification.
For tool body modification instructions, see page G16.

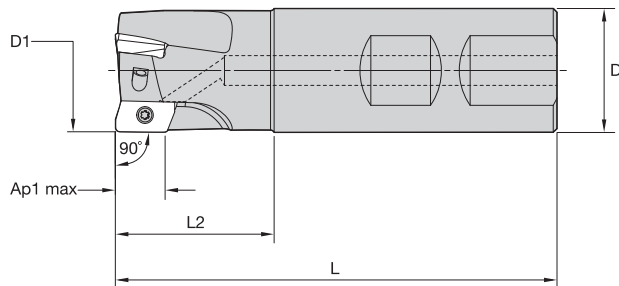
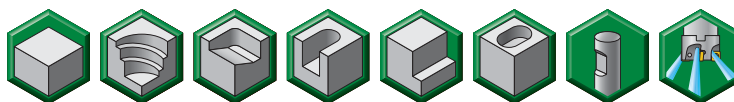

Shoulder Mills

■ **Weldon Shanks**

order number	catalogue number	D1	D	L	L2	Ap1 max	Z	max ramp angle	coolant supply	max RPM	kg
5988102	VSM17D025Z02B25XD17	25	25	90	33	16,3	2	8.8	Yes	41800	0,26
5988136	VSM17D032Z02B32XD17	32	32	100	39	16,3	2	5.7	Yes	34700	0,49
5988103	VSM17D032Z03B32XD17	32	32	100	39	16,3	3	5.7	Yes	34700	0,48
5988137	VSM17D040Z03B40XD17	40	40	110	39	16,2	3	4.0	Yes	29800	0,88
5988104	VSM17D040Z04B40XD17	40	40	110	39	16,2	4	4.0	Yes	29800	0,87

■ **Spare Parts**



insert screw

191.725



Nm

3,5



wrench

170.025

NOTE: Standard milling cutters will accept insert nose radii up to 1,6mm without modification.
For tool body modification instructions, see page G16.

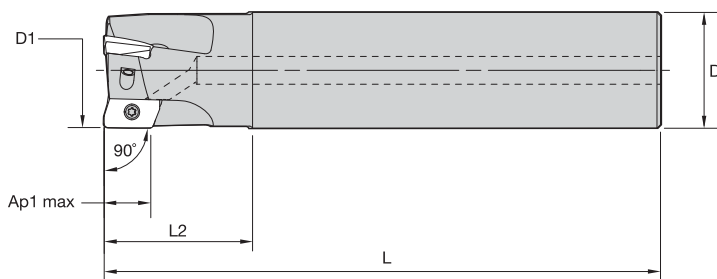
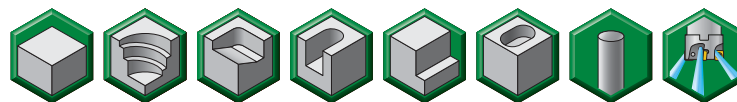

Shoulder Mills

■ Cylindrical End Mills

order number	catalogue number	D1	D	L	L2	Ap1 max	Z	max ramp angle	coolant supply	max RPM	kg
5988055	VSM17D025Z02A25XD17L110	25	25	110	44	16,3	2	8.8	Yes	41800	0,32
5988056	VSM17D025Z02A25XD17L170	25	25	170	44	16,3	2	8.8	Yes	41800	0,54
5988107	VSM17D032Z02A32XD17L120	32	32	120	50	16,3	2	5.7	Yes	34700	0,60
5988057	VSM17D032Z03A32XD17L120	32	32	120	50	16,3	3	5.7	Yes	34700	0,60
5988109	VSM17D040Z03A32XD17L130	40	32	130	50	16,2	3	4.0	Yes	29800	0,77
5988059	VSM17D040Z04A32XD17L130	40	32	130	50	16,2	4	4.0	Yes	29800	0,77

■ Spare Parts



insert screw

191.725



Nm

3,5



wrench

170.025

NOTE: Standard milling cutters will accept insert nose radii up to 1,6mm without modification.
For tool body modification instructions, see page G16.

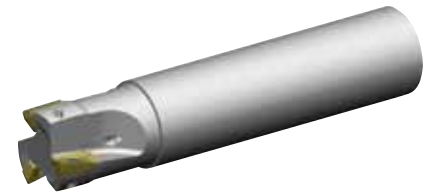
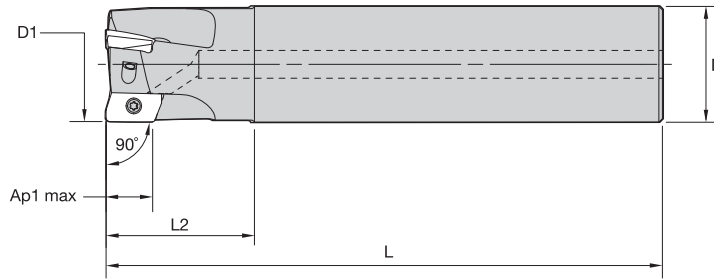
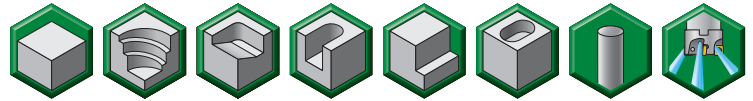

Shoulder Mills

■ Cylindrical End Mills • Long Shank

order number	catalogue number	D1	D	L	L2	Ap1 max	Z	max ramp angle	coolant supply	max RPM	kg
5988108	VSM17D032Z02A32XD17L210	32	32	210	50	16,3	2	5.7	Yes	34700	1,14
5988058	VSM17D032Z03A32XD17L210	32	32	210	50	16,3	3	5.7	Yes	34700	1,13
5988110	VSM17D040Z03A32XD17L250	40	32	250	50	16,2	3	4.0	Yes	29800	1,49
5988060	VSM17D040Z04A32XD17L250	40	32	250	50	16,2	4	4.0	Yes	29800	1,49

■ Spare Parts



insert screw

191.725



Nm

3,5



wrench

170.025

NOTE: Standard milling cutters will accept insert nose radii up to 1,6mm without modification.
For tool body modification instructions, see page G16.

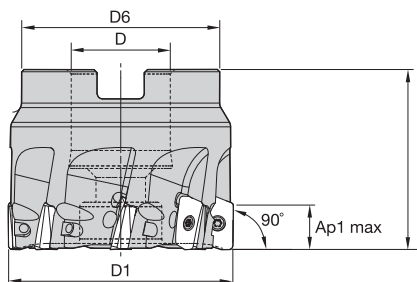
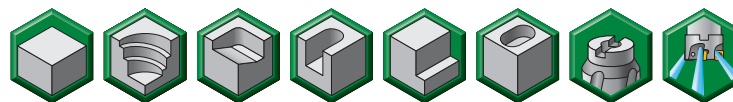

Shoulder Mills

■ Shell Mills

order number	catalogue number	D1	D	D6	L	Ap1 max	Z	max ramp angle	coolant supply	max RPM	kg
5988094	VSM17D040Z04S16XD17	40	16	37	40	16,2	4	4.0	Yes	29800	0,19
5988095	VSM17D050Z04S22XD17	50	22	45	40	16,1	4	3.0	Yes	25800	0,28
5988096	VSM17D050Z05S22XD17	50	22	45	40	16,1	5	3.0	Yes	25800	0,29
5988134	VSM17D050Z06S22XD17	50	22	45	40	16,1	6	3.0	Yes	25800	0,28
5988097	VSM17D063Z05S22XD17	63	22	50	40	16,0	5	2.1	Yes	22400	0,45
5988135	VSM17D063Z06S22XD17	63	22	50	40	16,0	6	2.1	Yes	22400	0,45
5988098	VSM17D080Z06S27XD17	80	27	60	50	15,9	6	1.6	Yes	19500	0,98
5988133	VSM17D080Z07S27XD17	80	27	60	50	15,9	7	1.6	Yes	19500	0,96
5988099	VSM17D100Z08S32XD17	100	32	80	50	15,8	8	1.2	Yes	17200	1,63
5988100	VSM17D125Z09S40XD17	125	40	90	63	15,7	9	0.9	Yes	15200	2,94
5988101	VSM17D160Z12S40XD17	160	40	100	63	15,6	12	0.7	Yes	13300	3,66

■ Spare Parts

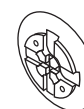

D1	insert screw	Nm	wrench	socket-head cap screw	socket-head cap screw with coolant groove	coolant lock screw assembly	coolant lock screw	coolant cap
40,0	191.725	3,5	170.025	MS1294	MS1294CG	-	-	-
50,0	191.725	3,5	170.025	MS1234	MS1294CG	-	-	-
50,0	191.725	3,5	170.025	MS1234	MS1234CG	-	-	-
63,0	191.725	3,5	170.025	MS1234	MS1234CG	-	-	-
80,0	191.725	3,5	170.025	MS2038	MS2038CG	-	-	-
100,0	191.725	3,5	170.025	-	-	MS2195C	-	-
125,0	191.725	3,5	170.025	-	-	MS2187C	-	-
160,0	191.725	3,5	170.025	-	-	-	12146107000	12146111100

NOTE: Standard milling cutters will accept insert nose radii up to 1,6mm without modification.
For tool body modification instructions, see page G16.

■ Insert Selection Guide

Material Group	Light Machining		General Purpose		Heavy Machining	
	Geometry	Grade	Geometry	Grade	Geometry	Grade
P1-P2	.E..ML	WP40PM	.S..MM	WP40PM	.S..MH	WP40PM
P3-P4	.E..ML	WP35CM	.S..MM	WP35CM	.S..MH	WP35CM
P5-P6	.E..ML	WP35CM	.S..MM	WU35PM	.S..MH	WP35CM
M1-M2	.E..ML	WP25PM	.S..MM	WP25PM	.S..MM	WU35PM
M3	.E..ML	WP35CM	.S..MM	WP35CM	.S..MH	WP35CM
K1-K2	.S..MM	WK15CM	.S..MM	WK15CM	.S..MH	WK15CM
K3	.E..ML	WP35CM	.S..MM	WP35CM	.S..MH	WP35CM
N1-N2	.F..ALP	WN10HM	.F..ALP	WN25PM	.F..ALP	WN25PM
N3	-	-	-	-	-	-
S1-S2	.S..MM	WP25PM	.S..MM	WU35PM	.S..MM	WU35PM
S3	.S..MM	WU35PM	.S..MM	WU35PM	.S..MM	WU35PM
S4	.S..MM	WP25PM	.S..MM	WU35PM	.S..MM	WU35PM
H1	.S..MM	WP25PM	.S..MM	WP25PM	-	-

Shoulder Mills



XDCT-ML

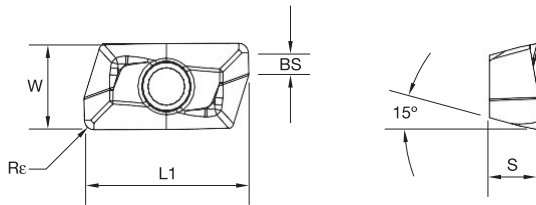

● first choice
○ alternate choice



P	●	○	○	○	○	○	○	○	○
M	●	○	○	○	○	○	○	○	○
K	●	○	○	○	○	○	○	○	○
N	●	○	○	○	○	○	○	○	○
S	●	○	○	○	○	○	○	○	○
H	●	○	○	○	○	○	○	○	○

■ XDCT-ML

catalogue number	cutting edges	L1	BS	S	W	Rε	hm	WK15CM	WN25PM	WP25PM	WP35CM	WP40PM	WU35PM
XDCT170404PEERML	2	19,15	2,62	4,90	9,60	0,40	0,04	●	●	○	○	○	○
XDCT170408PEERML	2	19,15	2,22	4,90	9,60	0,80	0,04	●	●	○	○	○	○
XDCT170412PEERML	2	19,16	1,82	4,90	9,60	1,20	0,04	●	●	○	○	○	○
XDCT170416PEERML	2	19,17	1,42	4,90	9,60	1,60	0,04	●	●	○	○	○	○
XDCT170420PEERML	2	19,17	1,01	4,90	9,60	2,00	0,04	●	●	○	○	○	○
XDCT170424PEERML	2	19,17	0,63	4,90	9,60	2,40	0,04	●	●	○	○	○	○
XDCT170432PEERML	2	18,85	—	4,88	9,59	3,20	0,04	●	●	○	○	○	○
XDCT170440PEERML	2	18,33	—	4,87	9,59	4,00	0,04	●	●	○	○	○	○

Shoulder Mills



XDCT-ALP

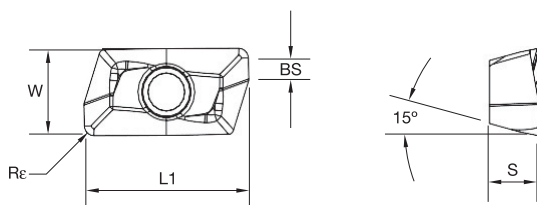

● first choice
○ alternate choice

P			
M			
K			
N	●	●	
S			
H			

■ XDCT-ALP

catalogue number	cutting edges	L1	BS	S	W	Re	hm	WNT10HM		WN25PM	
								6007341	6007220	6007345	6007344
XDCT170404PEFRALP	2	19,15	2,62	4,90	9,60	0,40	0,02				
XDCT170408PEFRALP	2	19,15	2,22	4,90	9,60	0,80	0,02				
XDCT170412PEFRALP	2	19,16	1,82	4,90	9,60	1,20	0,02			6007342	6001537
XDCT170416PEFRALP	2	19,17	1,42	4,90	9,60	1,60	0,02			6001256	6001254
XDCT170420PEFRALP	2	19,17	1,01	4,90	9,60	2,00	0,02			6001252	6001254
XDCT170424PEFRALP	2	19,17	0,63	4,90	9,60	2,40	0,02			6001252	6001254
XDCT170432PEFRALP	2	18,85	—	4,88	9,59	3,20	0,02			6001238	6001240
XDCT170440PEFRALP	2	18,33	—	4,87	9,59	4,00	0,02			6001238	6001240

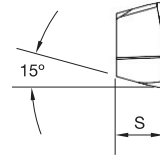
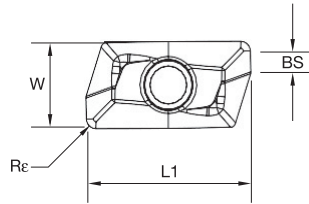

● first choice
○ alternate choice

P	●	○	○	○	○	○	○
M	●	○	○	○	○	○	○
K	●	○	○	○	○	○	○
N	●	○	○	○	○	○	○
S	●	○	○	○	○	○	○
H	●	○	○	○	○	○	○

■ XDPT-MM

catalogue number	cutting edges	L1	BS	S	W	Re	hm	WK15CM	WN25PM	WP25PM	WP35CM	WP40PM	WU35PM
XDPT170404PESRMM	2	19,15	2,52	4,90	9,60	0,40	0,10	●	○	○	○	○	○
XDPT170408PESRMM	2	19,15	2,15	4,90	9,60	0,80	0,10	●	○	○	○	○	○
XDPT170412PESRMM	2	19,16	1,77	4,90	9,60	1,20	0,10	●	○	○	○	○	○
XDPT170416PESRMM	2	19,17	1,38	4,90	9,60	1,60	0,10	●	○	○	○	○	○
XDPT170420PESRMM	2	19,17	0,99	4,90	9,60	2,00	0,10	●	○	○	○	○	○
XDPT170424PESRMM	2	19,17	0,62	4,90	9,60	2,40	0,10	●	○	○	○	○	○
XDPT170432PESRMM	2	18,85	—	4,89	9,59	3,20	0,10	●	○	○	○	○	○
XDPT170440PESRMM	2	18,33	—	4,87	9,59	4,00	0,10	●	○	○	○	○	○

■ XDPT-MH

catalogue number	cutting edges	L1	BS	S	W	Re	hm	WK15CM	WN25PM	WP25PM	WP35CM	WP40PM	WU35PM
XDPT170408PESRMH	2	19,15	2,10	4,91	9,60	0,80	0,13	●	○	○	○	○	○
XDPT170412PESRMH	2	19,16	1,73	4,91	9,60	1,20	0,13	●	○	○	○	○	○

Shoulder Mills

■ Recommended Starting Speeds [m/min]

Shoulder Mills

Material Group		WK15CM	WN25PM	WP25PM	WP35CM	WP40PM	WN10HM	WU35PM
P	1	- - -	- - -	330 285 270	455 395 370	295 260 245	- - -	260 230 215
	2	- - -	- - -	275 240 200	280 255 230	250 215 180	- - -	220 190 160
	3	- - -	- - -	255 215 175	255 230 205	230 195 160	- - -	200 170 140
	4	- - -	- - -	225 185 150	190 175 160	205 170 135	- - -	180 150 120
	5	- - -	- - -	185 170 150	260 230 210	170 155 135	- - -	150 135 120
	6	- - -	- - -	165 125 100	160 135 110	150 115 90	- - -	130 100 80
M	1	- - -	- - -	205 180 165	205 185 155	195 170 155	- - -	170 150 135
	2	- - -	- - -	185 160 130	185 160 140	175 150 125	- - -	155 130 110
	3	- - -	- - -	140 120 95	145 130 115	130 115 90	- - -	115 100 80
K	1	420 385 340	- - -	230 205 185	295 265 240	- - -	190 170 150	- - -
	2	335 295 275	- - -	180 160 150	235 210 190	- - -	- - -	- - -
	3	280 250 230	- - -	150 135 120	195 175 160	- - -	- - -	- - -
N	1	- - -	1075 945 875	- - -	- - -	- - -	2000 1200 1000	- - -
	2	- - -	945 875 760	- - -	- - -	- - -	1365 815 665	- - -
	3	- - -	945 875 760	- - -	- - -	- - -	800 500 400	- - -
S	1	- - -	- - -	40 35 25	- - -	40 35 30	- - -	35 30 25
	2	- - -	- - -	40 35 25	- - -	40 35 30	- - -	35 30 25
	3	- - -	- - -	50 40 25	- - -	50 40 30	- - -	45 35 25
	4	- - -	- - -	70 50 35	66 50 33	65 50 35	- - -	60 45 30
H	1	- - -	- - -	120 90 70	- - -	- - -	- - -	- - -
	2	- - -	- - -	- - -	- - -	- - -	- - -	- - -
	3	- - -	- - -	- - -	- - -	- - -	- - -	- - -

NOTE: FIRST choice starting speeds are in **bold** type.
As the average chip thickness increases, the speed should be decreased.

Recommended Starting Feeds

■ Recommended Starting Feeds [mm]

Light Machining	General Purpose	Heavy Machining
-----------------	-----------------	-----------------

Insert Geometry	Programmed Feed per Tooth (fz) as a % of Radial Depth of Cut (ae)															Insert Geometry
	5%			10%			20%			30%			40-100%			
.F..ALP	0,12	0,23	0,58	0,08	0,17	0,42	0,06	0,13	0,31	0,06	0,11	0,27	0,05	0,10	0,25	.F..ALP
.E..ML	0,16	0,35	0,70	0,12	0,25	0,50	0,09	0,19	0,38	0,08	0,16	0,33	0,07	0,15	0,30	.E..ML
.S..MM	0,16	0,46	0,87	0,12	0,33	0,63	0,09	0,25	0,47	0,08	0,22	0,41	0,07	0,20	0,38	.S..MM
.S..MH	0,23	0,58	0,93	0,17	0,42	0,67	0,13	0,31	0,50	0,11	0,27	0,44	0,10	0,25	0,40	.S..MH

NOTE: Use "Light Machining" value as starting feed rate.

Order a VSM17™ Kit to achieve true 90° high-performance shoulder milling!

Victory™ Shoulder Mill 17™ Starter Kits

Order one of our starter kits and test the performance of our new VSM17 platform. The kits are set up to serve the majority of shoulder milling applications, delivered with a cutter body and the latest WIDIA™ Victory™ grades. Detailed order information can be found in the table below.



■ VSM17 Starter Kits • Metric

order number	catalogue number	diameter D1 (mm)	cutter body type	material group	content					
					cutter	qty	inserts	qty	grade	Z (Pocket Seats)
6049187	VSM17KITCD025Z2WP40PM	25	CYLINDRICAL	P	VSM17D025Z02A25XD17L110	1	XDPT170408PESRMM	10	WP40PM	2
6049185	VSM17KITSW025Z2WP40PM	25	SCREW ON	P	VSM17D025Z02M12XD17	1	XDPT170408PESRMM	10	WP40PM	2
6049186	VSM17KITWD025Z2WP40PM	25	WELDON	P	VSM17D025Z02B25XD17	1	XDPT170408PESRMM	10	WP40PM	2
6049190	VSM17KITCD032Z3WP40PM	32	CYLINDRICAL	P	VSM17D032Z03A32XD17L120	1	XDPT170408PESRMM	10	WP40PM	3
6049188	VSM17KITSW032Z3WP40PM	32	SCREW ON	P	VSM17D032Z03M16XD17	1	XDPT170408PESRMM	10	WP40PM	3
6049189	VSM17KITWD032Z3WP40PM	32	WELDON	P	VSM17D032Z03B32XD17	1	XDPT170408PESRMM	10	WP40PM	3
6049311	VSM17KITCD032Z2WP40PM	32	CYLINDRICAL	P	VSM17D032Z02A32XD17L120	1	XDPT170408PESRMM	10	WP40PM	2
6049313	VSM17KITCD040Z4WP40PM	40	CYLINDRICAL	P	VSM17D040Z04A32XD17L130	1	XDPT170408PESRMM	10	WP40PM	4
6049312	VSM17KITSD040Z4WP40PM	40	SHELL MILL	P	VSM17D040Z04S16XD17	1	XDPT170408PESRMM	10	WP40PM	4
6049314	VSM17KITSD050Z4WP40PM	50	SHELL MILL	P	VSM17D050Z04S22XD17	1	XDPT170408PESRMM	10	WP40PM	4
6049315	VSM17KITSD050Z5WP40PM	50	SHELL MILL	P	VSM17D050Z05S22XD17	1	XDPT170408PESRMM	10	WP40PM	5
6049316	VSM17KITSD063Z5WP40PM	63	SHELL MILL	P	VSM17D063Z05S22XD17	1	XDPT170408PESRMM	10	WP40PM	5
6049317	VSM17KITSD080Z6WP40PM	80	SHELL MILL	P	VSM17D080Z06S27XD17	1	XDPT170408PESRMM	10	WP40PM	6
6049318	VSM17KITSD100Z8WP40PM	100	SHELL MILL	P	VSM17D100Z08S32XD17	1	XDPT170408PESRMM	10	WP40PM	8
6049321	VSM17KITCD025Z2WK15CM	25	CYLINDRICAL	K	VSM17D025Z02A25XD17L110	1	XDPT170408PESRMM	10	WK15CM	2
6049319	VSM17KITSW025Z2WK15CM	25	SCREW ON	K	VSM17D025Z02M12XD17	1	XDPT170408PESRMM	10	WK15CM	2
6049320	VSM17KITWD025Z2WK15CM	25	WELDON	K	VSM17D025Z02B25XD17	1	XDPT170408PESRMM	10	WK15CM	2
6049324	VSM17KITCD032Z3WK15CM	32	CYLINDRICAL	K	VSM17D032Z03A32XD17L120	1	XDPT170408PESRMM	10	WK15CM	3
6049322	VSM17KITSW032Z3WK15CM	32	SCREW ON	K	VSM17D032Z03M16XD17	1	XDPT170408PESRMM	10	WK15CM	3
6049323	VSM17KITWD032Z3WK15CM	32	WELDON	K	VSM17D032Z03B32XD17	1	XDPT170408PESRMM	10	WK15CM	3
6049325	VSM17KITCD032Z2WK15CM	32	CYLINDRICAL	K	VSM17D032Z02A32XD17L120	1	XDPT170408PESRMM	10	WK15CM	2
6049327	VSM17KITCD040Z4WK15CM	40	CYLINDRICAL	K	VSM17D040Z04A32XD17L130	1	XDPT170408PESRMM	10	WK15CM	4
6049326	VSM17KITSD040Z4WK15CM	40	SHELL MILL	K	VSM17D040Z04S16XD17	1	XDPT170408PESRMM	10	WK15CM	4
6049328	VSM17KITSD050Z4WK15CM	50	SHELL MILL	K	VSM17D050Z04S22XD17	1	XDPT170408PESRMM	10	WK15CM	4
6049329	VSM17KITSD050Z5WK15CM	50	SHELL MILL	K	VSM17D050Z05S22XD17	1	XDPT170408PESRMM	10	WK15CM	5
6049330	VSM17KITSD063Z5WK15CM	63	SHELL MILL	K	VSM17D063Z05S22XD17	1	XDPT170408PESRMM	10	WK15CM	5
6049331	VSM17KITSD080Z6WK15CM	80	SHELL MILL	K	VSM17D080Z06S27XD17	1	XDPT170408PESRMM	10	WK15CM	6
6049332	VSM17KITSD100Z8WK15CM	100	SHELL MILL	K	VSM17D100Z08S32XD17	1	XDPT170408PESRMM	10	WK15CM	8

Double-Sided Shoulder Mill •
VSM490™ -15

VSM490-15



WIDIA™ Victory™ Shoulder Milling Series (VSM series) is specially engineered to achieve excellent surface quality as well as higher material removal rates in shoulder milling applications. The VSM490 series, with its unique design, enables the tool to be applied in multiple passes (stepping down) with outstanding results. VSM490-15 is applicable in a wide range of workpiece materials: steel, cast iron, stainless steel, and titanium, from roughing to finishing applications.

- Double-sided strong insert with 4 cutting edges.
- High positive geometry for lower cutting forces.
- Superior wall and surface finish capabilities.

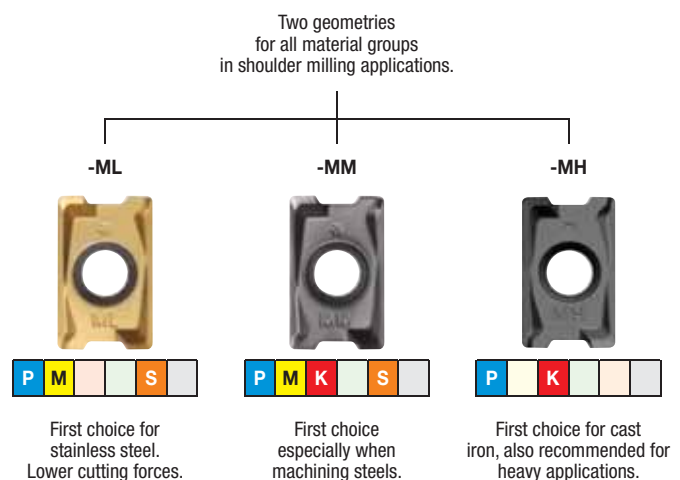
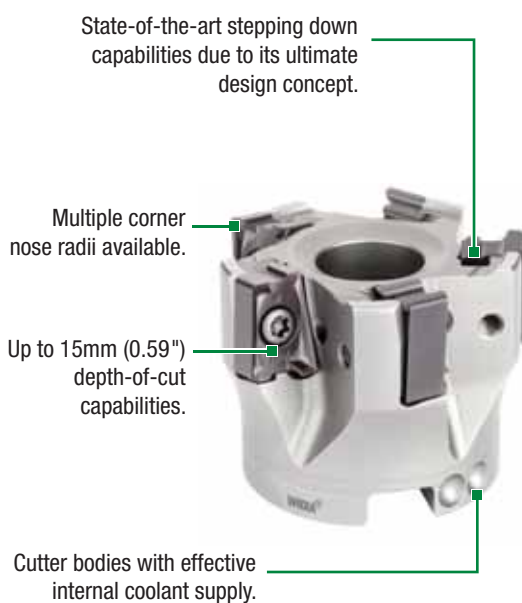

90° Shoulder Mills



VSM490™-15

Max depth of cut: 15mm

Lead angle: 90°

Indexes per insert: 4

Diameter: 25–160mm

Pages: G32–G40

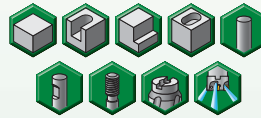

VSM490™-15 • Unbeatable Performance in Shoulder Milling

- “Stepless” solution.
- No mismatch when machining walls in different steps.

Innovative cutting geometry provides superior wall and surface finish.

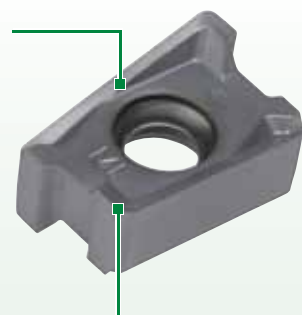

Integrated wiper facet for excellent floor finishing.

Competitor Tool • Wall Quality



Traditional tools are designed to achieve a 90° wall, but exhibit poor performance when machining walls in multiple passes.

VSM490-15 • Wall Quality



VSM490-15 minimises the marks left. By increasing wall quality and avoiding a second tool, productivity increases significantly.

- Superior wall and surface finish capabilities.
- “Stepless” solution. True 90° to run precise applications in multiple axial passes.
- Strong concept to run up to 15mm (.590") depth of cut.
- Effective internal coolant feature, reaching the cutting edge precisely.

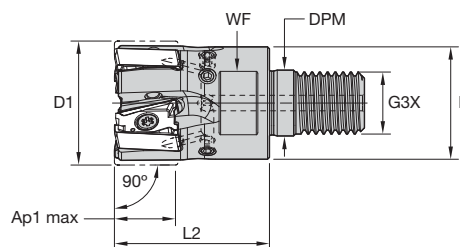
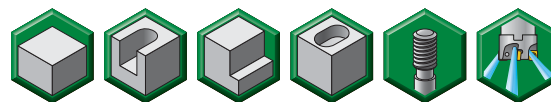

Shoulder Mills

■ Screw-On End Mills

order number	catalogue number	D1	D	DPM	G3X	L2	WF	Ap1 max	Z	kg	max RPM
5873211	VSM490D025Z02M12XN15	25	21	13	M12	32	17	15,0	2	0,18	26700
5873212	VSM490D032Z03M16XN15	32	29	17	M16	40	24	15,0	3	0,18	22000
5873213	VSM490D032Z04M16XN15	32	29	17	M16	40	24	15,0	4	0,18	22000
5873214	VSM490D035Z04M16XN15	35	29	17	M16	40	24	15,0	4	0,19	20600

■ Spare Parts



insert screw

MS-2071



Nm

3,5



Torx Plus driver

DT15IP

- Superior wall and surface finish capabilities.
- “Stepless” solution. True 90° to run precise applications in multiple axial passes.
- Strong concept to run up to 15mm (.590") depth of cut.
- Effective internal coolant feature, reaching the cutting edge precisely.

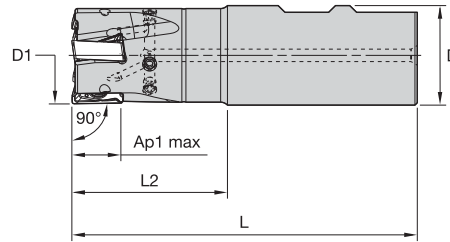
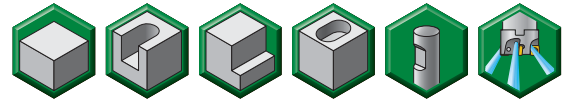

Shoulder Mills

■ **Weldon Shanks**

order number	catalogue number	D1	D	L	L2	Ap1 max	Z	kg	max RPM
5710285	VSM490D025Z02B25XN15	25	25	89	32	15,0	2	0,28	26700
5710286	VSM490D032Z03B32XN15	32	32	111	50	15,0	3	0,58	22000
5873215	VSM490D040Z03B32XN15	40	32	111	50	15,0	3	0,65	18800

NOTE: Weldon type not recommended for finishing operations.

■ **Spare Parts**



insert screw

MS-2071



Nm

3,5



Torx Plus driver

DT151P

- Superior wall and surface finish capabilities.
- “Stepless” solution. True 90° to run precise applications in multiple axial passes.
- Strong concept to run up to 15mm (.590") depth of cut.
- Effective internal coolant feature, reaching the cutting edge precisely.

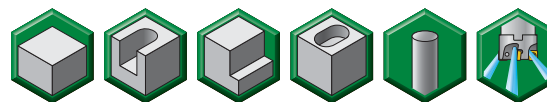

Shoulder Mills

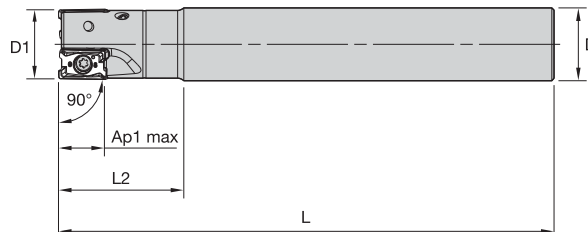

■ Cylindrical End Mills

order number	catalogue number	D1	D	L	L2	Ap1 max	Z	kg	max RPM
5873216	VSM490D025Z02A25XN15L100	25	25	100	43	15,0	2	0,32	26700
5710287	VSM490D025Z02A25XN15L170	25	25	170	43	15,0	2	0,59	26700
5873217	VSM490D032Z03A32XN15L110	32	32	110	49	15,0	3	0,59	22000
5710288	VSM490D032Z03A32XN15L200	32	32	200	50	15,0	3	1,14	22000
5873218	VSM490D032Z04A32XN15L110	32	32	110	49	15,0	4	0,58	22000
5873219	VSM490D032Z04A32XN15L200	32	32	200	50	15,0	4	1,14	22000

■ Spare Parts



insert screw

MS-2071



Nm

3,5



Torx Plus driver

DT15IP

- Superior wall and surface finish capabilities.
- “Stepless” solution. True 90° to run precise applications in multiple axial passes.
- Strong concept to run up to 15mm (.590") depth of cut.
- Effective internal coolant feature, reaching the cutting edge precisely.

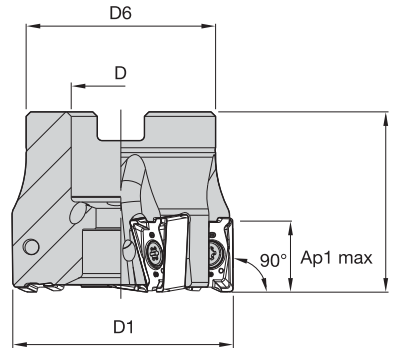
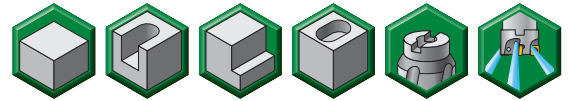

Shoulder Mills

■ Shell Mills

order number	catalogue number	D1	D	D6	L	Ap1 max	Z	kg	max RPM
5710289	VSM490D040Z04S16XN15	40	16	37	40	15,0	4	0,20	18800
5710520	VSM490D040Z05S16XN15	40	16	37	40	15,0	5	0,19	18800
5873221	VSM490D050Z04S22XN15	50	22	42	40	15,0	4	0,28	16300
5710521	VSM490D050Z05S22XN15	50	22	42	40	15,0	5	0,28	16300
5710522	VSM490D050Z06S22XN15	50	22	42	40	15,0	6	0,28	16300
5873222	VSM490D063Z05S22XN15	63	22	50	40	15,0	5	0,50	14200
5710523	VSM490D063Z06S22XN15	63	22	50	40	15,0	6	0,49	14200
5710524	VSM490D063Z07S22XN15	63	22	50	40	15,0	7	0,48	14200
5873223	VSM490D080Z05S27XN15	80	27	60	50	15,0	5	1,03	12300
5710525	VSM490D080Z07S27XN15	80	27	60	50	15,0	7	1,03	12300
5873224	VSM490D080Z09S27XN15	80	27	60	50	15,0	9	1,04	12300
5710526	VSM490D100Z08S32XN15	100	32	80	50	15,0	8	1,61	10900
5873225	VSM490D100Z11S32XN15	100	32	80	50	15,0	11	1,64	10900
5873226	VSM490D125Z09S40XN15	125	40	90	63	15,0	9	2,96	9600
5873227	VSM490D125Z12S40XN15	125	40	90	63	15,0	12	3,11	9600
5873228	VSM490D160Z12S40XN15	160	40	110	63	15,0	12	4,80	8400

■ Spare Parts

D1	insert screw	Nm	Torx Plus driver	socket-head cap screw	socket-head cap screw with coolant groove	coolant lock screw assembly	coolant lock screw	coolant shower plate
40	MS-2071	3,5	DT15IP	125.825	MS1294CG	—	—	—
50	MS-2071	3,5	DT15IP	125.025	MS1234CG	—	—	—
63	MS-2071	3,5	DT15IP	125.025	MS1234CG	—	—	—
80	MS-2071	3,5	DT15IP	125.230	MS2038CG	—	—	—
100	MS-2071	3,5	DT15IP	—	—	MS2189C	—	—
125	MS-2071	3,5	DT15IP	—	—	MS2187C	—	—
160	MS-2071	3,5	DT15IP	—	—	—	420.200	470.233

NOTE: Socket-head cap screw with coolant groove and coolant lock screw assembly must be ordered separately.

■ Insert Selection Guide

Shoulder Mills

Material Group	Light Machining		General Purpose		Heavy Machining	
	Geometry	Grade	Geometry	Grade	Geometry	Grade
P1-P2	XNGU-ML	WP40PM	XNPU-ML	WP40PM	XNPU-MM	WP40PM
P3-P4	XNGU-ML	WP25PM	XNPU-MM	WP35CM	XNPU-MM	WP40PM
P5-P6	XNGU-MM	WP25PM	XNPU-MM	WP35CM	XNPU-MM	WP35CM
M1-M2	XNGU-ML	WP25PM	XNGU-ML	WU35PM	XNGU-MM	WU35PM
M3	XNGU-ML	WP25PM	XNGU-ML	WU35PM	XNGU-MM	WU35PM
K1-K2	XNGU-MH	WK15CM	XNGU-MH	WK15CM	XNGU-MH	WP35CM
K3	XNGU-MH	WK15PM	XNGU-MH	WK15PM	XNGU-MH	WP40PM
N1-N2	-	-	-	-	-	-
N3	-	-	-	-	-	-
S1-S2	XNGU-ML	WP25PM	XNGU-ML	WU35PM	XNGU-MM	WU35PM
S3	XNGU-ML	WP25PM	XNGU-ML	WU35PM	XNGU-MM	WU35PM
S4	XNGU-ML	WU35PM	XNGU-ML	WU35PM	XNPU-MM	WU35PM
H1	-	-	-	-	-	-

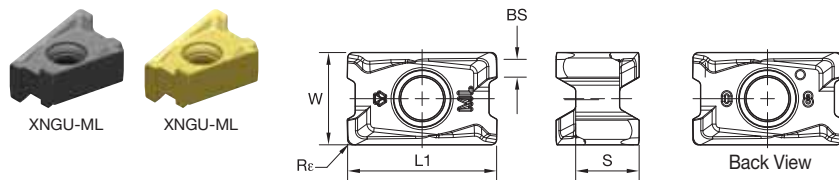

• -ML geometry is the first choice for machining stainless steel. With reduced cutting forces, this is recommended for improved wall finishing capabilities in steels.

● first choice
○ alternate choice

P	●	○	○	○	○	○	○
M	●	●	●	○	○	○	○
K	●	○	○	○	○	○	○
N	○	○	○	○	○	○	○
S	●	●	○	○	○	○	○
H	○	○	○	○	○	○	○

■ XNGU-ML • Precision Finishing

catalogue number	cutting edges	L1	S	W	BS	Rε	hm	WK15PM	WP25PM	WU35PM	WP40PM	WK15CM	WP35CM
XNGU15T604ERML	4	16,20	6,88	10,00	2,20	0,40	0,08		5890821	5890823	5890822		
XNGU15T608ERML	4	16,20	6,88	10,00	1,80	0,80	0,08		5873481	5873483	5873482		

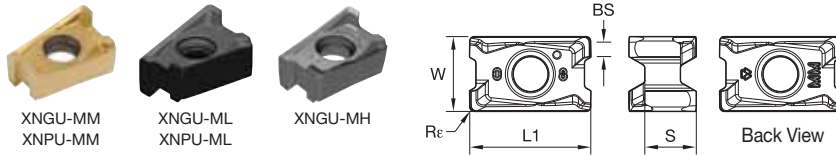

- -ML geometry is the first choice for machining stainless steel. With reduced cutting forces, this is recommended for improved wall finishing capabilities in steels.
- -MM is the universal geometry for VSM490-15. First choice when machining steel, as well as stainless steel and high-temp alloys in heavy applications.
- -MH geometry is the first choice for cast iron machining in the medium and heavy applications.

● first choice
○ alternate choice

P	●	○	○	○	○	○	○
M	●	●	●	○	○	○	○
K	○	○	○	○	○	○	○
N	○	○	○	○	○	○	○
S	○	○	○	○	○	○	○
H	○	○	○	○	○	○	○

■ XNGU-MM • Precision Finishing

catalogue number	cutting edges	L1	S	W	BS	Rε	hm	WK15PM	WP25PM	WU35PM	WP40PM	WK15CM	WP35CM
XNGU15T604SRMM	4	16,20	6,88	10,00	2,20	0,40	0,10	-	5949204	5949206	5949205	-	-
XNGU15T608SRMM	4	16,20	6,88	10,00	1,90	0,80	0,10	-	5710527	5710529	5710528	-	-

■ XNPU-ML • Utility Roughing

catalogue number	cutting edges	L1	S	W	BS	Rε	hm	WK15PM	WP25PM	WU35PM	WP40PM	WK15CM	WP35CM
XNPU15T608ERML	4	16,10	6,88	10,00	1,90	0,80	0,08	-	5883097	5883099	5883098	-	-

■ XNPU-MM • Utility Roughing

catalogue number	cutting edges	L1	S	W	BS	Rε	hm	WK15PM	WP25PM	WU35PM	WP40PM	WK15CM	WP35CM
XNPU15T608SRMM	4	16,10	6,88	10,00	1,90	0,80	0,10	5873419	5873415	5873417	5873416	5873420	5873418
XNPU15T612SRMM	4	16,10	6,88	10,00	1,50	1,20	0,10	5890762	5890728	5890730	5890729	5890763	5890761
XNPU15T616SRMM	4	16,10	6,88	10,00	1,10	1,60	0,10	5883521	5883447	5883449	5883448	5883522	5883450

■ XNGU-MH • Utility Roughing

catalogue number	cutting edges	L1	S	W	BS	Rε	WK15PM	WP25PM	WU35PM	WP40PM	WK15CM	WP35CM
XNGU15T608SRMH	4	16,20	6,88	10,00	1,80	0,80	6003724	6003570	6003722	6003721	6003725	6003723
XNGU15T616SRMH	4	16,20	6,88	10,00	1,00	1,60	6030378	6030376	-	-	6030380	6030377

■ Recommended Starting Speeds [m/min]

Shoulder Mills

Material Group		WK15PM			WP25PM			WU35PM			WP40PM			WK15CM			WP35CM		
P	1	-	-	-	330	285	270	260	230	215	300	260	250	-	-	-	455	395	370
	2	-	-	-	275	240	200	220	190	160	250	220	180	-	-	-	280	255	230
	3	-	-	-	255	215	175	200	170	140	230	200	160	-	-	-	255	230	205
	4	-	-	-	225	185	150	180	150	120	210	170	140	-	-	-	190	175	160
	5	-	-	-	185	170	150	150	135	120	170	160	140	-	-	-	260	230	210
	6	-	-	-	165	125	100	130	100	80	150	120	90	-	-	-	160	135	110
M	1	-	-	-	205	180	165	170	150	135	200	170	160	-	-	-	205	185	155
	2	-	-	-	185	160	130	155	130	110	180	150	130	-	-	-	185	160	140
	3	-	-	-	140	120	95	115	100	80	130	120	90	-	-	-	145	130	115
K	1	270	245	215	230	205	185	-	-	-	-	-	-	420	385	340	295	265	240
	2	210	190	175	180	160	150	-	-	-	-	-	-	335	295	275	235	210	190
	3	175	160	145	150	135	120	-	-	-	-	-	-	280	250	230	195	175	160
N	1-2	-	-	-	-	-	-	-	-	-	-	-	-	-	-	-	-	-	-
	3	-	-	-	-	-	-	-	-	-	-	-	-	-	-	-	-	-	-
S	1	-	-	-	40	35	25	35	30	25	40	40	30	-	-	-	-	-	-
	2	-	-	-	40	35	25	35	30	25	40	40	30	-	-	-	-	-	-
	3	-	-	-	50	40	25	45	35	25	50	40	30	-	-	-	-	-	-
	4	-	-	-	70	50	35	60	45	30	70	50	40	-	-	-	-	-	-
H	1	-	-	-	-	-	-	-	-	-	-	-	-	-	-	-	-	-	-

NOTE: FIRST choice starting speeds are in **bold** type.
As the average chip thickness increases, the speed should be decreased.

Recommended Starting Feeds

■ Recommended Starting Feeds [mm]

Light Machining	General Purpose	Heavy Machining
-----------------	-----------------	-----------------

Insert Geometry	Programmed Feed per Tooth (fz) as a % of Radial Depth of Cut (ae)															Insert Geometry
	5%			10%			20%			30%			40-100%			
XN.U-ML	0,17	0,29	0,46	0,13	0,21	0,33	0,09	0,16	0,25	0,08	0,14	0,22	0,08	0,13	0,20	XN.U-ML
XN.U-MM	0,21	0,39	0,58	0,15	0,28	0,42	0,11	0,21	0,31	0,10	0,19	0,27	0,09	0,17	0,25	XN.U-MM
XNGU-MH	0,23	0,45	0,70	0,17	0,33	0,50	0,13	0,24	0,38	0,11	0,21	0,33	0,10	0,20	0,30	XNGU-MH

NOTE: Use "Light Machining" values as starting feed rate.

Order a VSM490™ Kit and experience the next level of shoulder milling!

VSM490-15 Starter Kits

Order one of our starter kits and test the performance of our new VSM490-15 platform. The kits are set up to serve the majority of shoulder milling applications and workpiece materials, delivered with a cutter body as well as 20 inserts from a premium WIDIA™ grade. Detailed order information can be found in the table below.



■ VSM490-15 Starter Kits • Metric

order number	catalogue number	cutter diameter/ flutes	cutter body type	material group	application range	content				
						cutter	qty	inserts	grade	qty
5966234	VSM490KITC-D25Z02WP40PM	25z2	CYLINDRICAL	P	▽▽	VSM490D025Z02A25XN15L170	1	XNPU15T608SRMM	WP40PM	20
5966235	VSM490KITC-D32Z03WP40PM	32z3	CYLINDRICAL	P	▽▽	VSM490D032Z03A32XN15L200	1	XNPU15T608SRMM	WP40PM	20
5966236	VSM490KITS-D40Z04WP40PM	40z4	SHELL MILL	P	▽▽	VSM490D040Z04S16XN15	1	XNPU15T608SRMM	WP40PM	20
5966237	VSM490KITS-D50Z05WP40PM	50z5	SHELL MILL	P	▽▽	VSM490D050Z05S22XN15	1	XNPU15T608SRMM	WP40PM	20
5966238	VSM490KITS-D50Z06WP40PM	50z6	SHELL MILL	P	▽▽	VSM490D050Z06S22XN15	1	XNPU15T608SRMM	WP40PM	20
5966239	VSM490KITS-D63Z06WP40PM	63z6	SHELL MILL	P	▽▽	VSM490D063Z06S22XN15	1	XNPU15T608SRMM	WP40PM	20
5966240	VSM490KITS-D80Z07WP40PM	80z7	SHELL MILL	P	▽▽	VSM490D080Z07S27XN15	1	XNPU15T608SRMM	WP40PM	20
5966251	VSM490KITS-D100Z08WP40PM	100z8	SHELL MILL	P	▽▽▽	VSM490D100Z08S32XN15	1	XNPU15T608SRMM	WP40PM	20

▽ Heavy/Roughing
 ▽▽ Medium
 ▽▽▽ Light Machining/Finishing

(continued)

(VSM490-15 Starter Kits • Metric — continued)

order number	catalogue number	cutter diameter/ flutes	cutter body type	material group	application range	content				
						cutter	qty	inserts	grade	qty
5966252	VSM490KITC-D25Z02WU35PM	25z2	CYLINDRICAL	M+S	▽▽▽	VSM490D025Z02A25XN15L170	1	XNGU15T608ERML	WU35PM	20
5966253	VSM490KITC-D32Z03WU35PM	32z3	CYLINDRICAL	M+S	▽▽▽	VSM490D032Z03A32XN15L200	1	XNGU15T608ERML	WU35PM	20
5966255	VSM490KITS-D40Z04WU35PM	40z4	SHELL MILL	M+S	▽▽▽	VSM490D040Z04S16XN15	1	XNGU15T608ERML	WU35PM	20
5966256	VSM490KITS-D50Z05WU35PM	50z5	SHELL MILL	M+S	▽▽▽	VSM490D050Z05S22XN15	1	XNGU15T608ERML	WU35PM	20
5966257	VSM490KITS-D50Z06WU35PM	50z6	SHELL MILL	M+S	▽▽▽	VSM490D050Z06S22XN15	1	XNGU15T608ERML	WU35PM	20
5966258	VSM490KITS-D63Z06WU35PM	63z6	SHELL MILL	M+S	▽▽▽	VSM490D063Z06S22XN15	1	XNGU15T608ERML	WU35PM	20
5966259	VSM490KITS-D80Z07WU35PM	80z7	SHELL MILL	M+S	▽▽▽	VSM490D080Z07S27XN15	1	XNGU15T608ERML	WU35PM	20
5966260	VSM490KITC-D25Z02WK15PM	25z2	CYLINDRICAL	K	▽	VSM490D025Z02A25XN15L170	1	XNPU15T608SRMM	WK15PM	20
5966261	VSM490KITC-D32Z03WK15PM	32z3	CYLINDRICAL	K	▽	VSM490D032Z03A32XN15L200	1	XNPU15T608SRMM	WK15PM	20
5966262	VSM490KITS-D40Z04WK15PM	40z4	SHELL MILL	K	▽	VSM490D040Z04S16XN15	1	XNPU15T608SRMM	WK15PM	20
5966263	VSM490KITS-D50Z05WK15PM	50z5	SHELL MILL	K	▽	VSM490D050Z05S22XN15	1	XNPU15T608SRMM	WK15PM	20
5966264	VSM490KITS-D50Z06WK15PM	50z6	SHELL MILL	K	▽	VSM490D050Z06S22XN15	1	XNPU15T608SRMM	WK15PM	20
5966265	VSM490KITS-D63Z07WK15PM	63z7	SHELL MILL	K	▽	VSM490D063Z07S22XN15	1	XNPU15T608SRMM	WK15PM	20
5966266	VSM490KITS-D80Z09WK15PM	80z9	SHELL MILL	K	▽	VSM490D080Z09S27XN15	1	XNPU15T608SRMM	WK15PM	20
5966267	VSM490KITS-D100Z11WK15PM	100z11	SHELL MILL	K	▽	VSM490D100Z11S32XN15	1	XNPU15T608SRMM	WK15PM	20

▽ Heavy/Roughing
 ▽▽ Medium
 ▽▽▽ Light Machining/Finishing

Good for You, Better for the Environment!

The WIDIA™ Carbide Recycling Programme can turn accumulated scrap carbide tooling in your shop into cash.

Carbide Recycling

EXTREME CHALLENGES. EXTREME RESULTS.

We pay cash for used carbide tooling, including coated or non-coated carbide inserts, drills, end mills, reamers, and taps, regardless of brand.

It's good for the environment and a responsible way to dispose of scrap carbide.

Our carbide recycling programme features:

- Easy-to-use web portal that shows what your scrap carbide is worth before sending it to us.
- Online forms that make it easy to ship scrap carbide to WIDIA.
- Green Box™ containers for safe, convenient shipping of scrap carbide to WIDIA.
- Cash payment for used carbide tooling.



For more information, contact your local WIDIA
Authorised Distributor or visit widia.com/services.

WIDIA 

Your General-Purpose Shoulder Mill Solution •

M680 Series 90° Shoulder Mill

For a large selection of geometries and grades for optimal stable insert support, look no further than the M680 Series for your most challenging milling operations. The small, strong inserts provide reliable results every time.

M680



- Wide selection of inserts to machine all material types.
- Two insert sizes optimise your application.
- Pockets designed for optimal accuracy with 90° shoulders.



90° Shoulder Mills



M680

Max depth of cut: 14,0mm

Lead angle: 90°

Indexes per insert: 2

Diameter: 25mm–160mm

Pages: G44–G51

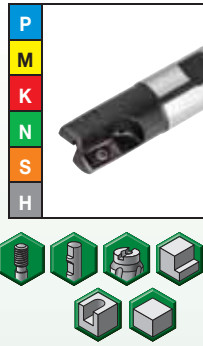

- General-purpose shoulder mill.
- Excellent selection of grades and geometries.
- Strong insert providing high reliability.

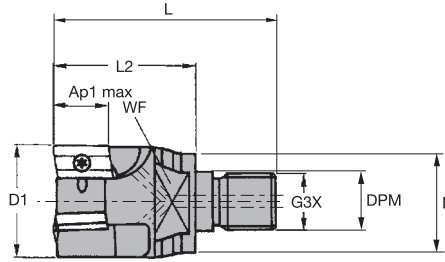
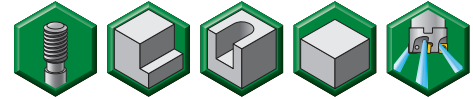

Shoulder Mills

■ Screw-On

order number	catalogue number	D1	D	DPM	G3X	L	L2	WF	Ap1 max	Z	max RPM	coolant supply	kg
2003477	12396932600	25	24	12,5	M12	52	30	19	14,0	2	8800	Yes	0,2
2003517	12396933000	32	28	17,0	M16	63	40	22	14,0	3	7800	Yes	0,3
2003521	12396933200	35	28	17,0	M16	63	40	22	14,0	3	7200	Yes	0,3
2003540	12396933400	40	28	17,0	M16	63	40	22	14,0	4	7000	Yes	0,3

NOTE: Standard milling cutters will accept insert nose radii up to 2mm without modification.
For tool body modification instructions, see page G16.

■ Spare Parts



D1	insert screw	Nm	Torx driver
25	12148038800	4,0	12148000600
32	12148038800	4,0	12148000600
35	12148038800	4,0	12148000600
40	12148038800	4,0	12148000600

- General-purpose shoulder mill.
- Excellent selection of grades and geometries.
- Strong insert offering high reliability.

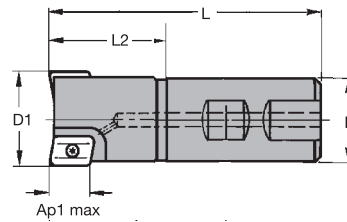
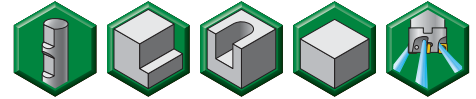

Shoulder Mills

■ **Weldon Shanks**

order number	catalogue number	D1	D	L	L2	Ap1 max	Z	max RPM	coolant supply	kg
2003475	12396922600	25	25	96	40	14,0	2	17500	Yes	0,3
2003515	12396923000	32	32	100	40	14,0	3	15500	Yes	0,5
2003539	12396923400	40	32	110	50	14,0	4	14000	Yes	0,8

NOTE: Standard milling cutters will accept insert nose radii up to 2mm without modification.
For tool body modification instructions, see page G16.

■ **Spare Parts**



D1	insert screw	Nm	Torx driver
25	12148038800	4,0	12148000600
32	12148038800	4,0	12148000600
40	12148038800	4,0	12148000600

- General-purpose shoulder mill.
- Excellent selection of grades and geometries.
- Strong insert providing high reliability.

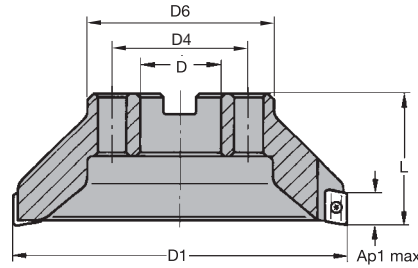
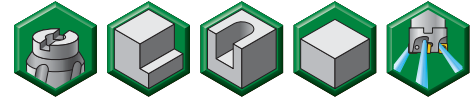

Shoulder Mills

■ Shell Mills

order number	catalogue number	D1	D	D4	D6	L	Ap1 max	Z	max RPM	coolant supply	kg
2003535	12396903600	40	22	—	39	45	14,0	4	14000	Yes	0,2
2003553	12396903800	50	22	—	42	40	14,0	4	12500	Yes	0,3
2003554	12396904000	50	22	—	42	40	14,0	5	12500	Yes	0,3
2003561	12396904200	63	22	—	50	40	14,0	5	11000	Yes	0,5
2003578	12396904600	80	27	—	60	50	14,0	6	9500	Yes	1,0
2003594	12396905000	100	32	—	78	50	14,0	8	8500	No	1,4
2003681	12396905400	125	40	—	89	63	14,0	9	7500	No	2,6
2003782	12396905800	160	40	66,7	90	63	14,0	12	7000	No	3,4

NOTE: Standard milling cutters will accept insert nose radii up to 2mm without modification.
For tool body modification instructions, see page G16.

■ Spare Parts



D1	insert screw	Nm	Torx driver
40	12148038800	4,0	12148000600
50	12148038800	4,0	12148000600
63	12148038800	4,0	12148000600
80	12148038800	4,0	12148000600
100	12148038800	4,0	12148000600
125	12148038800	4,0	12148000600
160	12148038800	4,0	12148000600

■ **Insert Selection Guide**

Material Group	Light Machining		General Purpose		Heavy Machining	
	Geometry	Grade	Geometry	Grade	Geometry	Grade
P1-P2	XPHT-GE	WP40PM	XPHT..	WP40PM	XPHT..	WP40PM
P3-P4	XPHT-GE	TN6540	XPHT..	WP40PM	XPHT..	WP40PM
P5-P6	XPHT-GE	TN6540	XPHT..	WP40PM	XPHT..	WP40PM
M1-M2	XPHT-GE	TN6540	XPHT..	TN6540	XPHT-MR	TN6540
M3	XPHT-GE	TN7535	XPHT..	WP40PM	XPHT-MR	TN7535
K1-K2	XPHT-GE	TN6510	XPHT..	TN6520	XPHT-MR	WK15CM
K3	XPHT-GE	TN6510	XPHT..	TN7535	XPHT-MR	WK15CM
N1-N2	XPHT-ALP	TN6501	XPHT-ALP	TN6501	XPHT-ALP	TN6501
N3	XPHT-ALP	TN6501	XPHT-ALP	TN6501	XPHT-ALP	TN6501
S1-S2	XPHT-GE	TN6540	XPHT..	TN6540	XPHT-MR	TN6540
S3	XPHT-GE	WS30PM	XPHT..	TN6540	XPHT-MR	TN6540
S4	XPHT-GE	TN6540	XPHT..	TN6540	XPHT-MR	TN6540
H1	XPHT-GE	WS30PM	XPHT..	TN6540	XPHT-MR	TN6540

Shoulder Mills

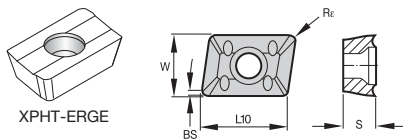

- first choice
- alternate choice

P	●			
M	●			
K	●			○
N	●	●	●	
S	●			○
H				

■ **XPHT-ALP**

catalogue number	cutting edges	W	L10	S	BS	Re	hm	TN6501	THM-U	THM
XPHT160404ALP	2	9,80	15,67	4,66	1,70	0,40	0,08		2031794	
XPHT160408ALP	2	9,80	15,67	4,66	1,70	0,80	0,08	2964136	2031797	
XPHT160412ALP	2	9,80	15,67	4,66	1,40	1,20	0,08		2031799	

■ Recommended Starting Speeds [m/min]

Shoulder Mills

Material Group		THM-U	TN2510	TN6501	TN6510	TN6520	TN6525	TN6540
P	0	- - -	- - -	- - -	- - -	- - -	340 265 235	300 235 200
	1	- - -	550 485 450	- - -	- - -	- - -	340 265 235	300 235 200
	2	- - -	340 310 275	- - -	- - -	- - -	265 210 180	210 160 140
	3	- - -	310 275 255	- - -	- - -	- - -	235 180 155	180 140 115
	4	- - -	230 215 190	- - -	- - -	- - -	195 140 120	150 110 90
	5	- - -	275 250 230	- - -	- - -	- - -	260 195 165	200 150 125
	6	- - -	190 170 145	- - -	- - -	- - -	170 135 110	135 100 85
M	1	- - -	225 200 175	- - -	- - -	- - -	160 100 65	110 65 50
	2	- - -	205 175 160	- - -	- - -	- - -	100 65 40	65 40 35
	3	- - -	160 145 125	- - -	- - -	- - -	105 65 45	70 40 35
K	1	190 170 150	350 300 250	- - -	400 290 215	375 265 190	230 205 185	185 170 150
	2	- - -	300 250 210	- - -	350 235 170	325 210 160	180 160 150	145 130 115
	3	- - -	250 210 165	- - -	280 215 165	250 190 135	150 135 120	130 120 105
N	1	2000 1200 1000	- - -	2000 1200 1000	- - -	- - -	- - -	- - -
	2	1365 815 665	- - -	1365 815 665	- - -	- - -	- - -	- - -
	3	800 500 400	- - -	800 500 400	- - -	- - -	- - -	- - -
S	1	- - -	- - -	- - -	- - -	- - -	- - -	40 30 25
	2	- - -	- - -	- - -	- - -	- - -	- - -	20 15 10
	3	- - -	- - -	- - -	- - -	- - -	- - -	60 35 25
	4	- - -	- - -	- - -	- - -	- - -	- - -	50 25 20
H	1	- - -	115 90 60	- - -	- - -	- - -	- - -	- - -
	2	- - -	115 90 60	- - -	- - -	- - -	- - -	- - -
	3	- - -	85 65 45	- - -	- - -	- - -	- - -	- - -

(continued)

(Recommended Starting Speeds [m/min] – continued)

Material Group		TN7525			TN7535			TTI25			WK15CM			WP40PM			WS30PM		
P	0	340	260	235	455	395	370	360	300	250	-	-	-	295	260	245	-	-	-
	1	340	260	235	455	395	370	360	300	250	-	-	-	295	260	245	-	-	-
	2	260	210	180	280	255	230	260	210	180	-	-	-	250	215	180	-	-	-
	3	235	180	155	255	230	205	260	210	180	-	-	-	230	195	160	-	-	-
	4	195	140	120	190	175	160	220	180	150	-	-	-	205	170	135	-	-	-
	5	260	195	165	260	230	210	265	195	165	-	-	-	170	155	135	-	-	-
	6	170	135	110	160	135	110	120	90	75	-	-	-	150	115	90	-	-	-
M	1	205	185	155	205	185	155	400	260	180	-	-	-	195	170	155	225	200	185
	2	185	160	140	185	160	140	270	170	120	-	-	-	175	150	125	205	180	145
	3	145	130	115	145	130	115	265	175	120	-	-	-	130	115	90	155	135	105
K	1	315	235	200	295	265	240	185	155	130	420	385	340	-	-	-	-	-	-
	2	270	200	165	235	210	190	150	120	105	335	295	275	-	-	-	-	-	-
	3	200	165	140	195	175	160	120	105	85	280	250	230	-	-	-	-	-	-
N	1	-	-	-	-	-	-	-	-	-	-	-	-	-	-	-	-	-	-
	2	-	-	-	-	-	-	-	-	-	-	-	-	-	-	-	-	-	-
	3	-	-	-	-	-	-	-	-	-	-	-	-	-	-	-	-	-	-
S	1	-	-	-	-	-	-	-	-	-	-	-	-	40	35	30	45	40	30
	2	-	-	-	-	-	-	-	-	-	-	-	-	40	35	30	45	40	30
	3	-	-	-	-	-	-	-	-	-	-	-	-	50	40	30	55	45	30
	4	-	-	-	-	-	-	-	-	-	-	-	-	65	50	35	85	60	40
H	1	-	-	-	-	-	-	-	-	-	-	-	-	-	-	-	-	-	-
	2	-	-	-	-	-	-	-	-	-	-	-	-	-	-	-	-	-	-
	3	-	-	-	-	-	-	-	-	-	-	-	-	-	-	-	-	-	-

Shoulder Mills

NOTE: FIRST choice starting speeds are in **bold** type.
As the average chip thickness increases, the speed should be decreased.

Recommended Starting Feeds

■ Recommended Starting Feeds [mm]

Light Machining	General Purpose	Heavy Machining
-----------------	-----------------	-----------------

Insert Geometry	Programmed Feed per Tooth (fz) as a % of Radial Depth of Cut (ae)															Insert Geometry
	5%			10%			20%			30%			40-100%			
XPHT-ALP	0,12	0,35	0,58	0,08	0,25	0,42	0,06	0,19	0,31	0,06	0,17	0,27	0,05	0,15	0,25	XPHT-ALP
XPHT-GE	0,19	0,47	0,70	0,14	0,34	0,50	0,11	0,26	0,38	0,09	0,22	0,33	0,08	0,20	0,30	XPHT-GE
XPHT..	0,22	0,56	0,82	0,16	0,40	0,59	0,12	0,30	0,44	0,10	0,26	0,38	0,10	0,24	0,35	XPHT..
XPNT..	0,22	0,56	0,82	0,16	0,40	0,59	0,12	0,30	0,44	0,10	0,26	0,38	0,10	0,24	0,35	XPNT..
XPHT-MR	0,23	0,59	0,92	0,17	0,43	0,66	0,13	0,32	0,50	0,11	0,28	0,43	0,10	0,25	0,40	XPHT-MR

NOTE: Use "Light Machining" value as starting feed rate.

First Choice for Economical Shoulder Milling •
M690 Series 90° Shoulder Mills

M690



Designed to streamline even your most challenging milling operations, the M690 Series provides optimal chip evacuation, excellent shoulder finish, free cutting action, and solid tool design for optimal insert support.

- New SDMX inserts — helical cutting edges for smooth cutting.
- Strong insert and tool design for maximum productivity.
- Four cutting edges enable excellent machining economy.

Positive pockets and geometry for free cutting action.

Strong tool design for optimum insert support.

Accurate PSTS inserts offer excellent shoulder finish.

Designed for optimal chip evacuation.

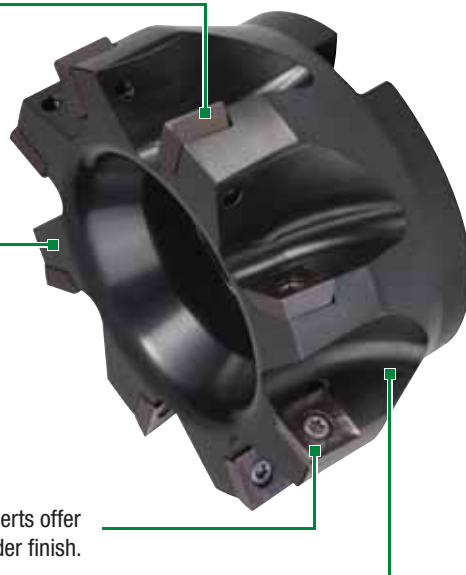

90° Shoulder Mills



M690 SD1204..

Max depth of cut: 10mm

Lead angle: 90°
Indexes per insert: 4
Diameter: 50–160mm

Pages: G54–G57



M690 SD1506..

Max depth of cut: 12mm

Lead angle: 90°
Indexes per insert: 4
Diameter: 50–125mm

Pages: G58–G61

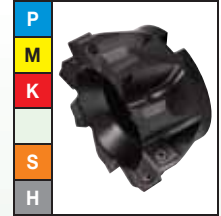

■ Insert Offering



12mm iC insert



15mm iC insert

- Four cutting edges.
- 90° shoulders.
- Excellent for slot and profile milling.

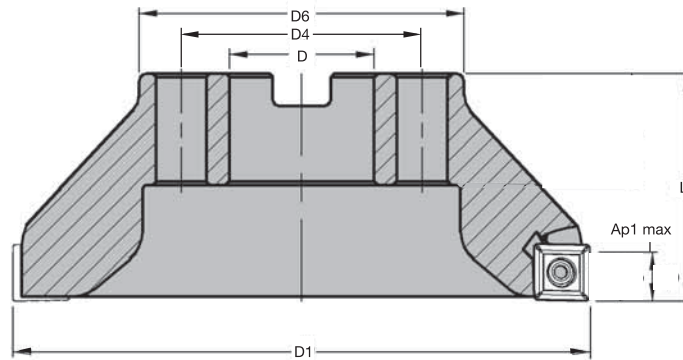
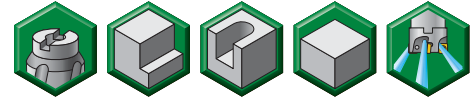

Shoulder Mills

■ Shell Mills

order number	catalogue number	D1	D	D4	D6	L	Ap1 max	Z	max RPM	coolant supply	kg
2003556	12396953800	50	22	—	47	40	10,0	4	22400	Yes	0,3
2003557	12396954000	50	22	—	47	40	10,0	5	22400	Yes	0,3
2003573	12396954200	63	22	—	50	40	10,0	5	20000	Yes	0,5
2003574	12396954400	63	22	—	50	40	10,0	6	20000	Yes	0,5
2003580	12396954600	80	27	—	60	50	10,0	6	17700	Yes	1,0
2003581	12396954800	80	27	—	60	50	10,0	8	17700	Yes	1,1
2003596	12396955000	100	32	—	78	50	10,0	8	15800	No	1,5
2003597	12396955200	100	32	—	78	50	10,0	10	15800	No	1,6
2003693	12396955400	125	40	—	89	63	10,0	9	14200	No	3,0
2003694	12396955600	125	40	—	89	63	10,0	12	14200	No	3,0
2003793	12396955800	160	40	66,7	90	63	10,0	12	12500	No	3,6
2003794	12396956000	160	40	66,7	90	63	10,0	15	12500	No	3,6

NOTE: Standard milling cutters will accept insert nose radius up to 2mm without modification.
For tool body modification instructions, see page G16.

■ Spare Parts



insert screw

12148037700



Nm

4,0



Torx driver

12148000600

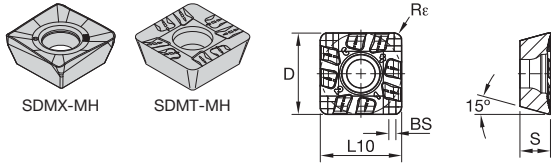

● first choice
○ alternate choice

P	○	○	○	○	○	○	○	○	○	○
M	○	○	○	○	○	○	○	○	○	○
K	○	○	○	○	○	○	○	○	○	○
N	○	○	○	○	○	○	○	○	○	○
S	○	○	○	○	○	○	○	○	○	○
H	○	○	○	○	○	○	○	○	○	○

Shoulder Mills

■ SDMX-MH

catalogue number	cutting edges	D	L10	S	BS	Re	hm	TN2510	TN6520	TN6525	TN6540	TN7525	TN7535	WK15CM	WS30PM
SDMX120408RMH	4	12,70	12,70	4,76	1,93	0,80	0,14	○	○	○	○	○	○	○	○
SDMX120412RMH	4	12,70	12,70	4,76	1,54	1,20	0,14	○	○	○	○	○	○	○	○
SDMX120416RMH	4	12,70	12,70	4,76	1,50	1,60	0,14	○	○	○	○	○	○	○	○

■ SDMT-MH

catalogue number	cutting edges	D	L10	S	BS	Re	hm	TN2510	TN6520	TN6525	TN6540	TN7525	TN7535	WK15CM	WS30PM
SDMT1204PDRMH	4	12,70	12,70	4,81	1,10	1,20	0,14	○	○	○	○	○	○	○	○

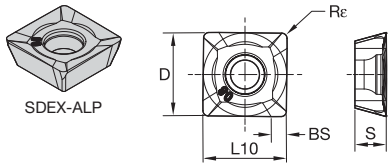

● first choice
○ alternate choice

P	○	○	○	○	○	○	○	○	○	○
M	○	○	○	○	○	○	○	○	○	○
K	○	○	○	○	○	○	○	○	○	○
N	○	○	○	○	○	○	○	○	○	○
S	○	○	○	○	○	○	○	○	○	○
H	○	○	○	○	○	○	○	○	○	○

■ SDEX-ALP

catalogue number	cutting edges	D	L10	S	BS	Re	hm	THM-U
SDEX120408FRALP	4	12,70	12,70	4,76	1,52	0,80	0,02	5281790

■ Recommended Starting Speeds [m/min]

Material Group		TN2510			TN6520			TN6525			TN6540			TN7525		
P	0	-	-	-	-	-	-	340	265	235	300	235	200	340	260	235
	1	550	485	450	-	-	-	340	265	235	300	235	200	340	260	235
	2	340	310	275	-	-	-	265	210	180	210	160	140	260	210	180
	3	310	275	255	-	-	-	235	180	155	180	140	115	235	180	155
	4	230	215	190	-	-	-	195	140	120	150	110	90	195	140	120
	5	275	250	230	-	-	-	260	195	165	200	150	125	260	195	165
	6	190	170	145	-	-	-	170	135	110	135	100	85	170	135	110
M	1	225	200	175	-	-	-	160	100	65	110	65	50	205	185	155
	2	205	175	160	-	-	-	100	65	40	65	40	35	185	160	140
	3	160	145	125	-	-	-	105	65	45	70	40	35	145	130	115
K	1	350	300	250	375	265	190	230	205	185	185	170	150	315	235	200
	2	300	250	210	325	210	160	180	160	150	145	130	115	270	200	165
	3	250	210	165	250	190	135	150	135	120	130	120	105	200	165	140
N	1	-	-	-	-	-	-	-	-	-	-	-	-	-	-	-
	2	-	-	-	-	-	-	-	-	-	-	-	-	-	-	-
	3	-	-	-	-	-	-	-	-	-	-	-	-	-	-	-
S	1	-	-	-	-	-	-	-	-	-	40	30	25	-	-	-
	2	-	-	-	-	-	-	-	-	-	20	15	10	-	-	-
	3	-	-	-	-	-	-	-	-	-	60	35	25	-	-	-
	4	-	-	-	-	-	-	-	-	-	50	25	20	-	-	-
H	1	115	90	60	-	-	-	-	-	-	-	-	-	-	-	-
	2	115	90	60	-	-	-	-	-	-	-	-	-	-	-	-
	3	85	65	45	-	-	-	-	-	-	-	-	-	-	-	-

Material Group		TN7535			WK15CM			WS30PM			TTI25			THM-U		
P	0	455	395	370	-	-	-	-	-	-	360	300	250	-	-	-
	1	455	395	370	-	-	-	-	-	-	360	300	250	-	-	-
	2	280	255	230	-	-	-	-	-	-	260	210	180	-	-	-
	3	255	230	205	-	-	-	-	-	-	260	210	180	-	-	-
	4	190	175	160	-	-	-	-	-	-	220	180	150	-	-	-
	5	260	230	210	-	-	-	-	-	-	265	195	165	-	-	-
	6	160	135	110	-	-	-	-	-	-	120	90	75	-	-	-
M	1	205	185	155	-	-	-	225	200	185	400	260	180	-	-	-
	2	185	160	140	-	-	-	205	180	145	270	170	120	-	-	-
	3	145	130	115	-	-	-	155	135	105	265	175	120	-	-	-
K	1	295	265	240	420	385	340	-	-	-	185	155	130	190	170	150
	2	235	210	190	335	295	275	-	-	-	150	120	105	-	-	-
	3	195	175	160	280	250	230	-	-	-	120	105	85	-	-	-
N	1	-	-	-	-	-	-	-	-	-	-	-	-	2000	1200	1000
	2	-	-	-	-	-	-	-	-	-	-	-	-	1365	815	665
	3	-	-	-	-	-	-	-	-	-	-	-	-	800	500	400
S	1	-	-	-	-	-	-	45	40	30	-	-	-	-	-	-
	2	-	-	-	-	-	-	45	40	30	-	-	-	-	-	-
	3	-	-	-	-	-	-	55	45	30	-	-	-	-	-	-
	4	-	-	-	-	-	-	85	60	40	-	-	-	-	-	-
H	1	-	-	-	-	-	-	-	-	-	-	-	-	-	-	-
	2	-	-	-	-	-	-	-	-	-	-	-	-	-	-	-
	3	-	-	-	-	-	-	-	-	-	-	-	-	-	-	-

NOTE: FIRST choice starting speeds are in **bold** type.
As the average chip thickness increases, the speed should be decreased.

Recommended Starting Feeds

■ Recommended Starting Feeds [mm]

Light Machining	General Purpose	Heavy Machining
-----------------	-----------------	-----------------

Insert Geometry	Programmed Feed per Tooth (fz) as a % of Radial Depth of Cut (ae)															Insert Geometry
	5%			10%			20%			30%			40-100%			
.F..ALP	0,12	0,23	0,46	0,08	0,17	0,33	0,06	0,13	0,25	0,06	0,11	0,22	0,05	0,10	0,20	.F..ALP
.E..ML	0,12	0,35	0,58	0,08	0,25	0,42	0,06	0,19	0,31	0,06	0,17	0,27	0,05	0,15	0,25	.E..ML
.S..MM	0,12	0,42	0,70	0,08	0,30	0,50	0,06	0,23	0,38	0,06	0,20	0,33	0,05	0,18	0,30	.S..MM
.S..MH	0,23	0,54	0,85	0,17	0,39	0,61	0,13	0,29	0,46	0,11	0,25	0,40	0,10	0,23	0,36	.S..MH

NOTE: Use "Light Machining" value as starting feed rate.

- Four cutting edges.
- 90° shoulders.
- Excellent for slot and profile milling.

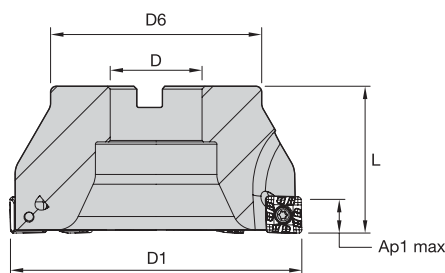

Shoulder Mills

■ Shell Mills

order number	catalogue number	D1	D	D6	L	Ap1 max	Z	max RPM	coolant supply	kg
2003555	12396943800	50	22	47	40	12,0	4	18500	Yes	0,3
2003562	12396944200	63	22	50	40	12,0	5	16100	Yes	0,4
2003579	12396944600	80	27	60	50	12,0	6	14000	Yes	0,9
2003595	12396945000	100	32	78	50	12,0	8	12300	No	1,3
2003682	12396945400	125	40	89	63	12,0	9	10800	No	2,7

■ Spare Parts



insert screw

MS2260



Nm

6,0



Torx driver

12148007500

Insert Selection Guide

Material Group	Light Machining		General Purpose		Heavy Machining	
	Geometry	Grade	Geometry	Grade	Geometry	Grade
P1-P2	.E..ML	TN6540	.S..MM	TN6540	.S..MH	TN6540
P3-P4	.E..ML	TN7535	.S..MM	TN6540	.S..MH	TN6540
P5-P6	.E..ML	TN7535	.S..MM	TN6540	.S..MH	TN6540
M1-M2	.E..ML	TN6540	.S..MM	TN6540	.S..MH	TN6540
M3	.E..ML	TN7535	.S..MM	TN7535	.S..MH	TN7535
K1-K2	.E..ML	WK15CM	.E..ML	WK15CM	.S..MH	WK15CM
K3	.E..ML	WK15CM	.S..MM	WK15CM	.S..MH	WK15CM
N1-N2	-	-	-	-	-	-
N3	-	-	-	-	-	-
S1-S2	.E..ML	TN6540	.S..MM	TN6540	.S..MM	TN6540
S3	.E..ML	TN6540	.S..MM	TN6540	.S..MM	TN6540
S4	.E..ML	TN6540	.S..MM	TN6540	.S..MM	TN6540
H1	.S..MM	TN6540	.S..MM	TN6540	.S..MM	TN6540

Inserts • SD1506..

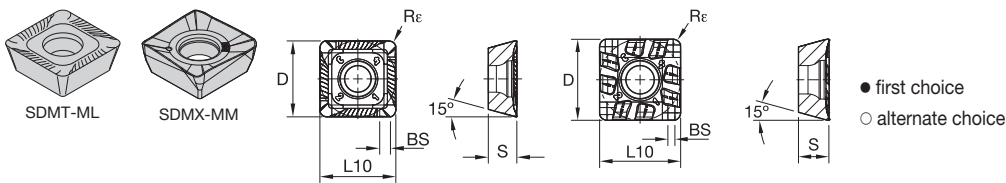

P	●	○	●	●	●	●	●
M	●	○	●	○	○	○	○
K	●	○	○	○	○	○	○
N	○	○	○	○	○	○	○
S	○	○	○	○	○	○	○
H	○	○	○	○	○	○	○

SDMT-ML

catalogue number	cutting edges	D	L10	S	BS	Re	hm	TN2510	TN6540	TN7525	TN7535	WK15CM
SDMT1506PDRML	4	15,88	15,88	6,32	1,10	1,20	0,08	●	●	●	●	●

SDMX-MM

catalogue number	cutting edges	D	L10	S	BS	Re	hm	TN2510	TN6540	TN7525	TN7535	WK15CM
SDMX150612RMM	4	15,88	15,88	6,35	1,45	1,20	0,14	○	○	○	○	○

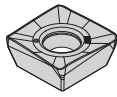

SDMX-MH

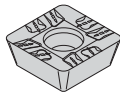

SDMT-MH

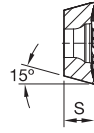
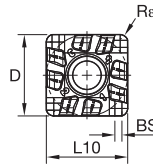

● first choice
○ alternate choice

P	<input type="radio"/>	<input type="radio"/>	<input type="radio"/>	<input type="radio"/>	<input type="radio"/>	<input type="radio"/>
M	<input type="radio"/>	<input type="radio"/>	<input type="radio"/>	<input type="radio"/>	<input type="radio"/>	<input type="radio"/>
K	<input type="radio"/>	<input type="radio"/>	<input type="radio"/>	<input type="radio"/>	<input type="radio"/>	<input type="radio"/>
N	<input type="radio"/>	<input type="radio"/>	<input type="radio"/>	<input type="radio"/>	<input type="radio"/>	<input type="radio"/>
S	<input type="radio"/>	<input type="radio"/>	<input type="radio"/>	<input type="radio"/>	<input type="radio"/>	<input type="radio"/>
H	<input type="radio"/>	<input type="radio"/>	<input type="radio"/>	<input type="radio"/>	<input type="radio"/>	<input type="radio"/>

■ SDMx-MH

catalogue number	cutting edges	D	L10	S	BS	Rε	hm	TN2510	TN6540	TN7525	TN7535	WK15CM
SDMX150612RMH	4	15,88	15,88	6,35	1,45	1,20	0,20	●	○	○	○	○
SDMX150616RMH	4	15,88	15,88	6,35	1,51	1,60	0,20	○	○	○	○	○

■ SDMT-MH

catalogue number	cutting edges	D	L10	S	BS	Rε	hm	TN2510	TN6540	TN7525	TN7535	WK15CM
SDMT1506PDRMH	4	15,88	15,88	6,35	1,10	1,20	0,20	○	○	○	○	○

Shoulder Mills

■ Recommended Starting Speeds [m/min]

Material Group		TN2510			TN6540			TN7525			TN7535			WK15CM		
P	0	-	-	-	300	235	200	340	260	235	455	395	370	-	-	-
	1	550	485	450	300	235	200	340	260	235	455	395	370	-	-	-
	2	340	310	275	210	160	140	260	210	180	280	255	230	-	-	-
	3	310	275	255	180	140	115	235	180	155	255	230	205	-	-	-
	4	230	215	190	150	110	90	195	140	120	190	175	160	-	-	-
	5	275	250	230	200	150	125	260	195	165	260	230	210	-	-	-
6	190	170	145	135	100	85	170	135	110	160	135	110	-	-	-	
M	1	225	200	175	110	65	50	205	185	155	205	185	155	-	-	-
	2	205	175	160	65	40	35	185	160	140	185	160	140	-	-	-
	3	160	145	125	70	40	35	145	130	115	145	130	115	-	-	-
K	1	350	300	250	185	170	150	315	235	200	295	265	240	420	385	340
	2	300	250	210	145	130	115	270	200	165	235	210	190	335	295	275
	3	250	210	165	130	120	105	200	165	140	195	175	160	280	250	230
N	1	-	-	-	-	-	-	-	-	-	-	-	-	-	-	-
	2	-	-	-	-	-	-	-	-	-	-	-	-	-	-	-
	3	-	-	-	-	-	-	-	-	-	-	-	-	-	-	-
S	1	-	-	-	40	30	25	-	-	-	-	-	-	-	-	-
	2	-	-	-	20	15	10	-	-	-	-	-	-	-	-	-
	3	-	-	-	60	35	25	-	-	-	-	-	-	-	-	-
	4	-	-	-	50	25	20	-	-	-	-	-	-	-	-	-
H	1	115	90	60	-	-	-	-	-	-	-	-	-	-	-	-
	2	115	90	60	-	-	-	-	-	-	-	-	-	-	-	-
	3	85	65	45	-	-	-	-	-	-	-	-	-	-	-	-

NOTE: FIRST choice starting speeds are in **bold** type.
As the average chip thickness increases, the speed should be decreased.

Shoulder Mills

Recommended Starting Feeds

■ Recommended Starting Feeds [mm]

Light Machining	General Purpose	Heavy Machining
-----------------	-----------------	-----------------

Insert Geometry	Programmed Feed per Tooth (fz) as a % of Radial Depth of Cut (ae)															Insert Geometry
	5%			10%			20%			30%			40-100%			
.F..ALP	0,12	0,23	0,46	0,08	0,17	0,33	0,06	0,13	0,25	0,06	0,11	0,22	0,05	0,10	0,20	.F..ALP
.E..ML	0,12	0,35	0,58	0,08	0,25	0,42	0,06	0,19	0,31	0,06	0,17	0,27	0,05	0,15	0,25	.E..ML
.S..MM	0,12	0,42	0,70	0,08	0,30	0,50	0,06	0,23	0,38	0,06	0,20	0,33	0,05	0,18	0,30	.S..MM
.S..MH	0,23	0,54	0,85	0,17	0,39	0,61	0,13	0,29	0,46	0,11	0,25	0,40	0,10	0,23	0,36	.S..MH

NOTE: Use "Light Machining" value as starting feed rate.

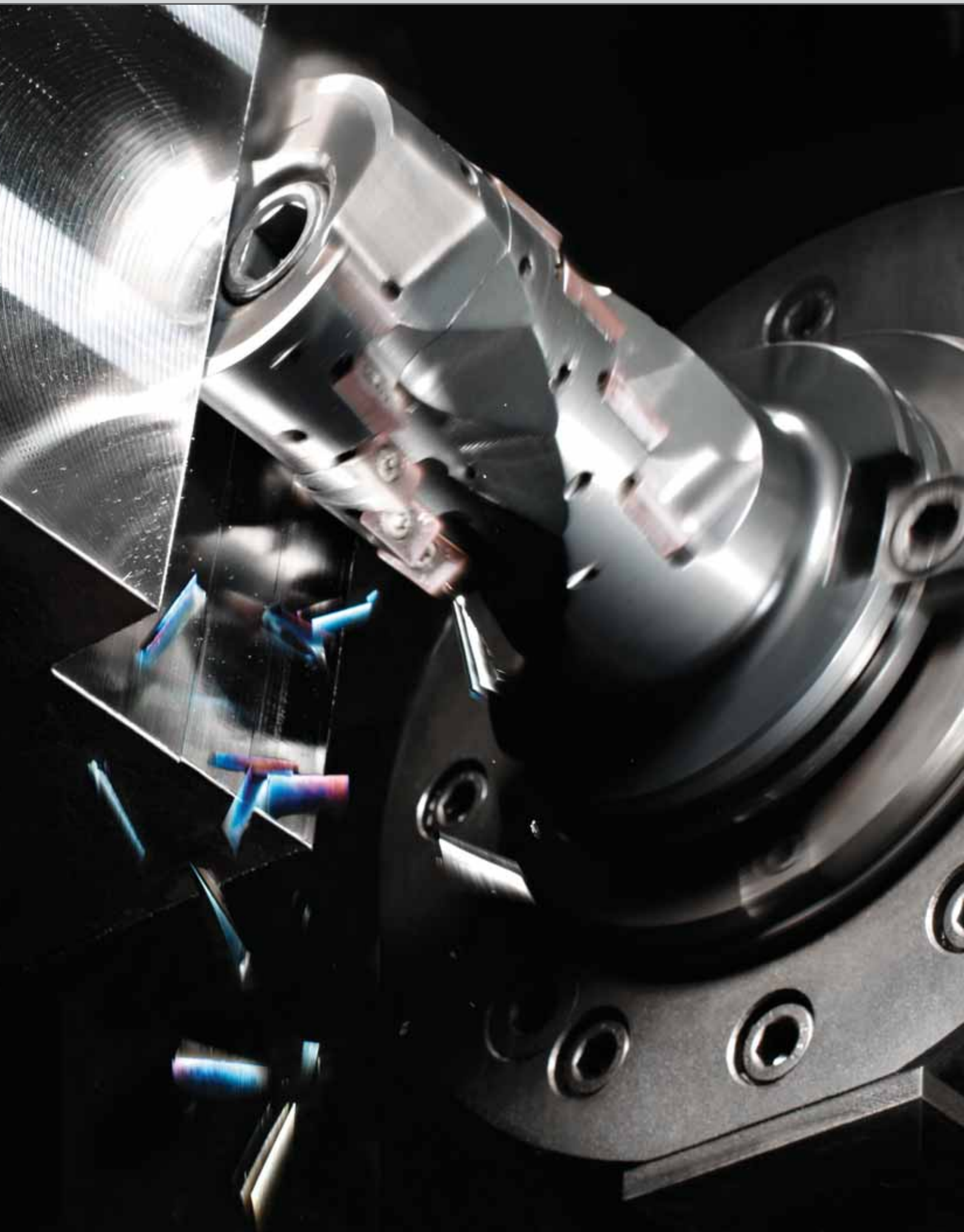

Indexable Milling • Helical Mills

M300 Series..... H2-H11



Reliable Option for Helical Milling Applications •

M300 Series

The dependable, general-purpose M300 Series provides high metal removal rates and consistent performance with a large selection of geometries and grades.



M300

- Wide selection of inserts to machine all material types.
- Positive spiral design for smooth cutting.
- Full effective teeth design ensures high performance.

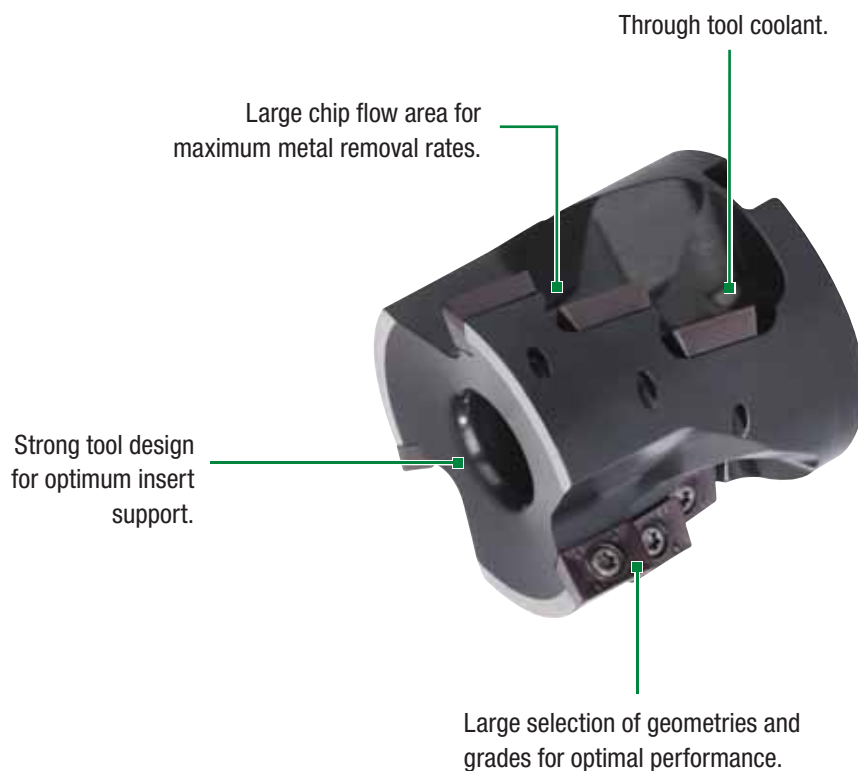

Helical Mills



M300

Max depth of cut: 112mm

Lead angle: 90°

Indexes per insert: 2

Diameter: 50–80mm

Pages: H4–H11



Maximum cutting depth (Ap1) and contact width (ae) ratios based on application type

Slot Milling

$ae = 1 \times D1$

$Ap1 \text{ max} = 0,6 \times D1$



**Not recommended in ISO "H" materials.*

Contouring

$ae = 0,25-0,4 \times D1$

$Ap1 \text{ max} = 1 \times D1$

$ae = >0,4 \times D1$

$Ap1 \text{ max} = 0,6 \times D1$



**Not recommended in ISO "H" materials.*

Profiling

$ae = >0,25 \times D1$

$Ap1 \text{ max} = Ap1 \text{ Max}$



- General-purpose helical mill.
- Excellent selection of grades and geometries.
- Strong insert providing high reliability.

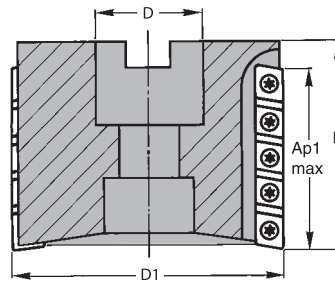
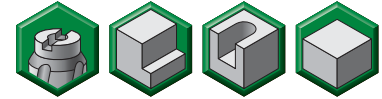

Helical Mills

■ Shell Mills

order number	catalogue number	D1	D	L	Ap1 max	Z	Z U	max RPM	coolant supply	kg
2021434	12393080200	50	22	50	28,0	6	3	13090	No	0,4
2021437	12393083200	50	22	65	42,0	12	4	13090	No	0,5
2021435	12393080400	63	27	61	42,0	9	3	11690	No	0,8
2021438	12393083400	63	27	75	56,0	20	5	11690	No	1,0
2021436	12393080600	80	32	70	56,0	16	4	10360	No	1,5
2021439	12393083600	80	32	85	70,0	30	6	10360	No	2,0

NOTE: Standard milling cutters will accept insert nose radii up to 2mm without modification.
 For tool body modification instructions, see page G16.
 Z = number of pocket seats.
 ZU = number of effective teeth.

■ Spare Parts



D1	insert screw	Nm	Torx driver
50	12148055800	4,0	12148000600
63	12148055800	4,0	12148000600
80	12148055800	4,0	12148000600

- Modular tool design.
- Excellent selection of grades and geometries.
- Strong insert providing high reliability.

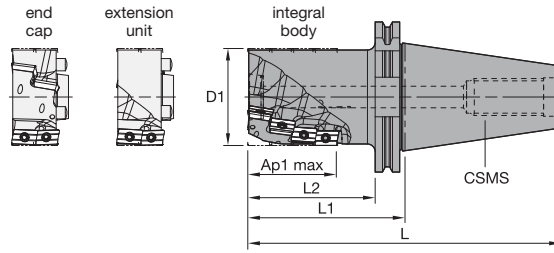
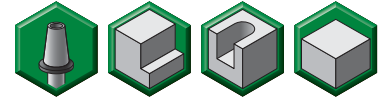

Helical Mills

■ **Integral**

order number	catalogue number	D1	L	L1	L2	Ap1 max	Z	Z U	CSMS system size	max RPM	kg
2021419	12393040200	50	217	115	96	70,0	15	3	DV50	13090	3,7
2021420	12393040400	63	232	130	111	84,0	18	3	DV50	11690	4,3
2021421	12393040800	80	257	155	136	112,0	32	4	DV50	10360	6,0

NOTE: Standard milling cutters will accept insert nose radii up to 2mm without modification.
For tool body modification instructions, see page G16.
Z = number of pocket seats.
ZU = number of effective teeth.

■ **Spare Parts**



D1	insert screw	Nm	Torx wrench	nose collar	socket-head cap screw
50	12148055800	4,0	12148000600	12393060200	12146021100
63	12148055800	4,0	12148000600	12393060400	12147517100
80	12148055800	4,0	12148000600	12393060800	12147517100

- Modular tool design.
- Excellent selection of grades and geometries.
- Strong insert offering high reliability.



Helical Mills

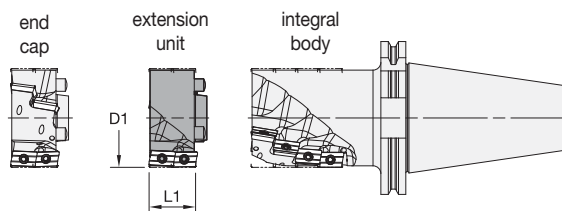

■ Extension Unit

order number	catalogue number	D1	L1	Z U	Z	kg
2021425	12393050200	50	28	3	6	0,3
2021426	12393050400	63	28	3	6	0,3
2021427	12393050800	80	28	4	8	0,6

NOTE: One spacer ring can be added to any M300 integral tool body assembly with matching D1.
 Standard assembly cap screw must be replaced with the following part for correct mounting bolt length:
 50mm — use longer socket head cap screw #12146030700 (M12 x 70).
 63mm and 80mm — use longer socket head cap screw #12146030800 (M16 x 70).
 Z = number of pocket seats.
 ZU = number of effective teeth.

- Modular tool design.
- Excellent selection of grades and geometries.
- Strong insert offering high reliability.

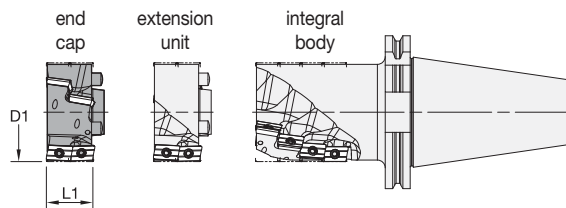

Helical Mills

■ End Cap

order number	catalogue number	D1	L1	Z U	Z	kg
2021431	12393060200	50	29	3	6	0,3
2021432	12393060400	63	29	3	6	0,4
2021433	12393060800	80	29	4	8	0,7

Note: Z = number of pocket seats.
ZU = number of effective teeth.

■ Insert Selection Guide

Material Group	Light Machining		General Purpose		Heavy Machining	
	Geometry	Grade	Geometry	Grade	Geometry	Grade
P1-P2	XPHT-GE	WP40PM	XPHT..	WP40PM	XPHT..	WP40PM
P3-P4	XPHT-GE	TN6540	XPHT..	WP40PM	XPHT..	WP40PM
P5-P6	XPHT-GE	TN6540	XPHT..	WP40PM	XPHT..	WP40PM
M1-M2	XPHT-GE	TN6540	XPHT..	TN6540	XPHT-MR	TN6540
M3	XPHT-GE	TN7535	XPHT..	WP40PM	XPHT-MR	TN7535
K1-K2	XPHT-GE	TN6510	XPHT..	TN6520	XPHT-MR	WK15CM
K3	XPHT-GE	TN6510	XPHT..	TN7535	XPHT-MR	WK15CM
N1-N2	XPHT-ALP	TN6501	XPHT-ALP	TN6501	XPHT-ALP	TN6501
N3	XPHT-ALP	TN6501	XPHT-ALP	TN6501	XPHT-ALP	TN6501
S1-S2	XPHT-GE	TN6540	XPHT..	TN6540	XPHT-MR	TN6540
S3	XPHT-GE	WS30PM	XPHT..	TN6540	XPHT-MR	TN6540
S4	XPHT-GE	TN6540	XPHT..	TN6540	XPHT-MR	TN6540
H1	XPHT-GE	WS30PM	XPHT..	TN6540	XPHT-MR	TN6540

Helical Mills

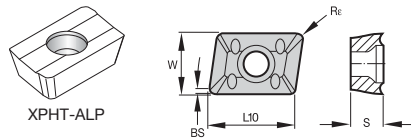

● first choice
○ alternate choice

P	●		
M			
K			
N	●		
S			
H			

■ XPHT-ALP

catalogue number	cutting edges	W	L10	S	BS	Re	hm	TN6501	THM-U
XPHT160404ALP	2	9,80	15,67	4,66	1,70	0,40	0,08	●	●
XPHT160408ALP	2	9,80	15,67	4,66	1,70	0,80	0,08	●	●
XPHT160412ALP	2	9,80	15,67	4,66	1,40	1,20	0,08	●	●

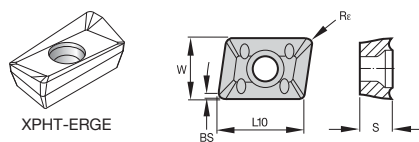

● first choice
○ alternate choice

P	○			●	●	●	●	●	●
M				○	●	○	○	○	○
K	●	●	●	○	○	○	●		
N									
S				●			●		
H	●								

■ XPHT-ERGE

catalogue number	cutting edges	W	L10	S	BS	Re	hm	TN2510	TN6510	TN6520	TN6525	TN6540	TN7525	TN7535	WK15CM	WS30PM	WP40PM	TT125
XPHT160408ERGE	2	9,44	15,67	4,76	1,80	0,80	0,12	●	●	●	●	●	●	●	●	●	●	●
XPHT160412ERGE	2	9,44	15,67	4,76	1,50	1,20	0,12	●	●	●	●	●	●	●	●	●	●	●
XPHT160416ERGE	2	9,44	15,67	4,76	0,80	1,67	0,06	●	●	●	●	●	●	●	●	●	●	●

■ Recommended Starting Speeds [m/min]

Helical Mills

Material Group		THM-U	TN2510	TN6501	TN6510	TN6520	TN6525	TN6540
P	0	- - -	- - -	- - -	- - -	- - -	340 265 235	300 235 200
	1	- - -	550 485 450	- - -	- - -	- - -	340 265 235	300 235 200
	2	- - -	340 310 275	- - -	- - -	- - -	265 210 180	210 160 140
	3	- - -	310 275 255	- - -	- - -	- - -	235 180 155	180 140 115
	4	- - -	230 215 190	- - -	- - -	- - -	195 140 120	150 110 90
	5	- - -	275 250 230	- - -	- - -	- - -	260 195 165	200 150 125
	6	- - -	190 170 145	- - -	- - -	- - -	170 135 110	135 100 85
M	1	- - -	225 200 175	- - -	- - -	- - -	160 100 65	110 65 50
	2	- - -	205 175 160	- - -	- - -	- - -	100 65 40	65 40 35
	3	- - -	160 145 125	- - -	- - -	- - -	105 65 45	70 40 35
K	1	190 170 150	350 300 250	- - -	400 290 215	375 265 190	230 205 185	185 170 150
	2	- - -	300 250 210	- - -	350 235 170	325 210 160	180 160 150	145 130 115
	3	- - -	250 210 165	- - -	280 215 165	250 190 135	150 135 120	130 120 105
N	1	2000 1200 1000	- - -	2000 1200 1000	- - -	- - -	- - -	- - -
	2	1365 815 665	- - -	1365 815 665	- - -	- - -	- - -	- - -
	3	800 500 400	- - -	800 500 400	- - -	- - -	- - -	- - -
S	1	- - -	- - -	- - -	- - -	- - -	- - -	40 30 25
	2	- - -	- - -	- - -	- - -	- - -	- - -	20 15 10
	3	- - -	- - -	- - -	- - -	- - -	- - -	60 35 25
	4	- - -	- - -	- - -	- - -	- - -	- - -	50 25 20
H	1	- - -	115 90 60	- - -	- - -	- - -	- - -	- - -
	2	- - -	115 90 60	- - -	- - -	- - -	- - -	- - -
	3	- - -	85 65 45	- - -	- - -	- - -	- - -	- - -

(continued)

(Recommended Starting Speeds [m/min] – continued)

Material Group		TN7525			TN7535			TTI25			WK15CM			WP40PM			WS30PM		
P	0	340	260	235	455	395	370	360	300	250	-	-	-	295	260	245	-	-	-
	1	340	260	235	455	395	370	360	300	250	-	-	-	295	260	245	-	-	-
	2	260	210	180	280	255	230	260	210	180	-	-	-	250	215	180	-	-	-
	3	235	180	155	255	230	205	260	210	180	-	-	-	230	195	160	-	-	-
	4	195	140	120	190	175	160	220	180	150	-	-	-	205	170	135	-	-	-
	5	260	195	165	260	230	210	265	195	165	-	-	-	170	155	135	-	-	-
	6	170	135	110	160	135	110	120	90	75	-	-	-	150	115	90	-	-	-
M	1	205	185	155	205	185	155	400	260	180	-	-	-	195	170	155	225	200	185
	2	185	160	140	185	160	140	270	170	120	-	-	-	175	150	125	205	180	145
	3	145	130	115	145	130	115	265	175	120	-	-	-	130	115	90	155	135	105
K	1	315	235	200	295	265	240	185	155	130	420	385	340	-	-	-	-	-	-
	2	270	200	165	235	210	190	150	120	105	335	295	275	-	-	-	-	-	-
	3	200	165	140	195	175	160	120	105	85	280	250	230	-	-	-	-	-	-
N	1	-	-	-	-	-	-	-	-	-	-	-	-	-	-	-	-	-	-
	2	-	-	-	-	-	-	-	-	-	-	-	-	-	-	-	-	-	-
	3	-	-	-	-	-	-	-	-	-	-	-	-	-	-	-	-	-	-
S	1	-	-	-	-	-	-	-	-	-	-	-	-	40	35	30	45	40	30
	2	-	-	-	-	-	-	-	-	-	-	-	-	40	35	30	45	40	30
	3	-	-	-	-	-	-	-	-	-	-	-	-	50	40	30	55	45	30
	4	-	-	-	-	-	-	-	-	-	-	-	-	65	50	35	85	60	40
H	1	-	-	-	-	-	-	-	-	-	-	-	-	-	-	-	-	-	-
	2	-	-	-	-	-	-	-	-	-	-	-	-	-	-	-	-	-	-
	3	-	-	-	-	-	-	-	-	-	-	-	-	-	-	-	-	-	-

NOTE: FIRST choice starting speeds are in **bold** type.
As the average chip thickness increases, the speed should be decreased.

Helical Mills

Recommended Starting Feeds

■ Recommended Starting Feeds [mm]

Light Machining	General Purpose	Heavy Machining
-----------------	-----------------	-----------------

Insert Geometry	Programmed Feed per Tooth (fz) as a % of Radial Depth of Cut (ae)															Insert Geometry
	5%			10%			20%			30%			40-100%			
XPHT-ALP	0,12	0,35	0,58	0,08	0,25	0,42	0,06	0,19	0,31	0,06	0,17	0,27	0,05	0,15	0,25	XPHT-ALP
XPHT-GE	0,19	0,47	0,70	0,14	0,34	0,50	0,11	0,26	0,38	0,09	0,22	0,33	0,08	0,20	0,30	XPHT-GE
XPHT..	0,22	0,56	0,82	0,16	0,40	0,59	0,12	0,30	0,44	0,10	0,26	0,38	0,10	0,24	0,35	XPHT..
XPNT..	0,22	0,56	0,82	0,16	0,40	0,59	0,12	0,30	0,44	0,10	0,26	0,38	0,10	0,24	0,35	XPNT..
XPHT-MR	0,23	0,59	0,92	0,17	0,43	0,66	0,13	0,32	0,50	0,11	0,28	0,43	0,10	0,25	0,40	XPHT-MR

NOTE: Use "Light Machining" value as starting feed rate.



Indexable Milling • Slotting Mills

M95 • Square Style Insert Slotting Platform 12-17
M900 • Adjustable Slotting Platform 18-119



M95 Series Slotting Mills

M95



M95 slotting cutters are ideal for deeper applications that require the cutting load to be shared from one insert to the other. They provide groove widths from 4–10mm and cutter diameters from 100–200mm as well as an economical way to achieve balanced cutting.

Features and Benefits

- Cutters available in arbour mount.
- Inserts with four indexes.
- Staggered keyways in mounting bore, used for multiple ganged cutters.
- Slot width 4–10mm.
- Three insert geometries available; SNHX in 11 and 12mm iC.
- Requires only one spare part.
- Economical to use.
- Available in Latest WIDIA™ Victory™ Grade.

Slotting Mills



M95

Slot Width Range:
4–10mm

Indexes per insert: 4
Diameter: 100–200mm

Pages: I4–I7

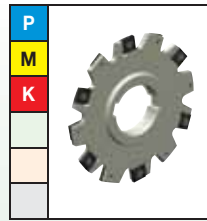

■ Insert Offering

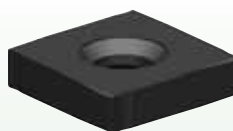

SNHX

Inserts with free-cutting
geometry providing
low cutting forces.

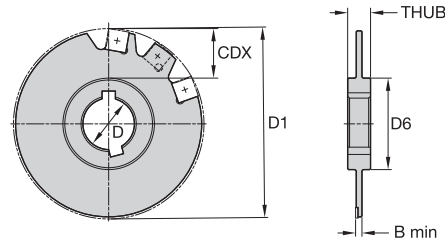
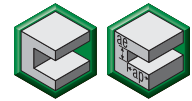

■ M95

order number	catalogue number	D1	D	D6	B min	CDX	THUB	Z	Z S	coolant supply	kg
2016502	12299510400	100	27	48	4	25,0	12,0	12	6	No	0,3
2016514	12299515500	100	27	48	5	25,0	12,0	12	6	No	0,3
2016516	12299515600	100	27	48	6	25,0	12,0	10	5	No	0,3
2016518	12299515700	100	27	48	7	25,0	12,0	9	3	No	0,3
2016520	12299515800	100	27	48	8	25,0	12,0	9	3	No	0,4
2016524	12299520400	125	40	58	4	32,5	12,0	14	7	No	0,4
2016526	12299525500	125	40	58	5	32,5	12,0	14	7	No	0,4
2016528	12299525600	125	40	58	6	32,5	12,0	12	6	No	0,5
2016530	12299525700	125	40	58	7	32,5	12,0	12	4	No	0,5
2016532	12299525800	125	40	58	8	32,5	12,0	12	4	No	0,6
2016544	12299526000	125	40	58	10	32,5	12,0	12	6	No	0,6
2016547	12299530400	160	40	68	4	45,0	12,0	18	9	No	0,7
2022648	12299535500	160	40	68	5	45,0	12,0	18	9	No	0,7
2016551	12299535600	160	40	68	6	45,0	12,0	16	8	No	1,0
2022649	12299535700	160	40	68	7	45,0	12,0	15	5	No	1,0
2016555	12299535800	160	40	68	8	45,0	12,0	15	5	No	1,1
2022650	12299536000	160	40	68	10	45,0	12,0	16	8	No	1,2
2016562	12299546000	200	22	72	10	63,0	12,0	18	9	No	1,9
2022652	12299545800	200	50	72	8	63,0	12,0	18	6	No	1,6

■ Spare Parts



D1	B min	insert screw	Nm	wrench	bushing
100	4	12147548500	1,2	170.023	—
100	5	12147562300	1,2	170.023	12147676800
100	6	12147548600	5,0	170.025	12147676900
100	7	12147548600	5,0	170.025	12147676900
100	8	12147548600	5,0	170.025	12147676900
125	4	12147548500	1,2	170.023	—
125	5	12147562300	1,2	170.023	12147676800
125	6	12147548600	5,0	170.025	12147676900
125	7	12147548600	5,0	170.025	12147676900
125	8	12147548600	5,0	170.025	12147676900
125	10	12147572400	5,0	170.025	12147677000
160	4	12147548500	1,2	170.023	—
160	5	12147562300	1,2	170.023	12147676800
160	6	12147548600	5,0	170.025	12147676900
160	7	12147548600	5,0	170.025	12147676900
160	8	12147548600	5,0	170.025	12147676900
160	10	12147572400	5,0	170.025	12147677000
200	8	12147548600	5,0	170.025	12147676900
200	10	12147572400	5,0	170.025	12147677000

■ **Insert Selection Guide**

Material Group	Light Machining		General Purpose		Heavy Machining	
	Geometry	Grade	Geometry	Grade	Geometry	Grade
P1-P2	SNHX	WP40PM	SNHX	WP40PM	SNHX	WP40PM
P3-P4	SNHX	WP35CM	SNHX	WP35CM	SNHX	WP35CM
P5-P6	SNHX	WP35CM	SNHX	WP35CM	SNHX	WP35CM
M1-M2	SNHX	WP40PM	SNHX	WP40PM	SNHX	WP40PM
M3	SNHX	WP35CM	SNHX	WP35CM	SNHX	WP35CM
K1-K2	SNHX	WK15CM	SNHX	WK15CM	SNHX	WK15CM
K3	SNHX	WP35CM	SNHX	WP35CM	SNHX	WP35CM
N1-N2	-	-	-	-	-	-
N3	-	-	-	-	-	-
S1-S2	-	-	-	-	-	-
S3	-	-	-	-	-	-
S4	-	-	-	-	-	-
H1	-	-	-	-	-	-

Slotting Mills

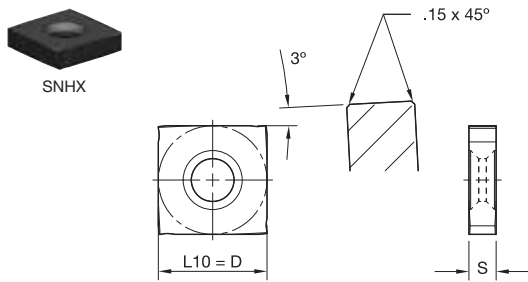

P	●	●	●
M	○	○	○
K	●	○	○
N	○	○	○
S	○	○	○
H	○	○	○

● first choice
○ alternate choice

■ **SNHX • 12,7mm iC**

catalogue number	cutting edges	D	L10	S	hm	WK15CM	WP35CM	WP40PM
123506601	4	12,70	12,70	3,18	0,08	5903650	5903674	5903646

■ **SNHX • 11mm iC**

catalogue number	cutting edges	D	L10	S	hm	WK15CM	WP35CM	WP40PM
123506599	4	11,00	11,00	2,30	0,08	5903648	5903672	5903644



SNHX

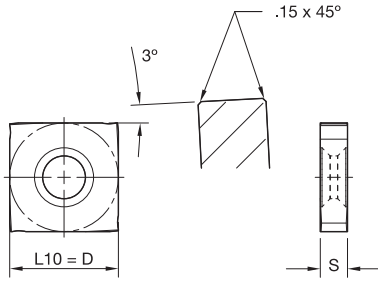

● first choice
○ alternate choice

P	●	●
M	○	●
K	●	○
N	○	○
S	○	○
H		

■ SNHX • 11mm iC

catalogue number	cutting edges	D	L10	S	hm	5903649	5903673	5903645
123506600	4	11,00	11,00	2,70	0,08	WK15CM	WP35CM	WP40PM

■ SNHX • 12,7mm iC

catalogue number	cutting edges	D	L10	S	hm	5903671	5903675	5903647
123506602	4	12,70	12,70	5,40	0,08	WK15CM	WP35CM	WP40PM

Slotting Mills

Recommended Starting Speeds [m/min]

Material Group		WK15CM			WP35CM			WP40PM		
P	0	-	-	-	455	395	370	295	260	245
	1	-	-	-	455	395	370	295	260	245
	2	-	-	-	280	255	230	250	215	180
	3	-	-	-	255	230	205	230	195	160
	4	-	-	-	190	175	160	205	170	135
	5	-	-	-	260	230	210	170	155	135
	6	-	-	-	160	135	110	150	115	90
M	1	-	-	-	205	185	155	195	170	155
	2	-	-	-	185	160	140	175	150	125
	3	-	-	-	145	130	115	130	115	90
K	1	420	385	340	295	265	240	-	-	-
	2	335	295	275	235	210	190	-	-	-
	3	280	250	230	195	175	160	-	-	-
N	1	-	-	-	-	-	-	-	-	-
	2	-	-	-	-	-	-	-	-	-
	3	-	-	-	-	-	-	-	-	-
S	1	-	-	-	-	-	-	-	-	-
	2	-	-	-	-	-	-	-	-	-
	3	-	-	-	-	-	-	-	-	-
	4	-	-	-	66	50	33	-	-	-
H	1	-	-	-	-	-	-	-	-	-
	2	-	-	-	-	-	-	-	-	-
	3	-	-	-	-	-	-	-	-	-

NOTE: FIRST choice starting speeds are in **bold** type.
 As the average chip thickness increases, the speed should be decreased.

Recommended Starting Feeds
Recommended Starting Feeds [mm]

Light Machining	General Purpose	Heavy Machining
-----------------	-----------------	-----------------

Insert Geometry	Programmed Feed per Tooth (fz) as a % of Radial Depth of Cut (ae)															Insert Geometry
	5%			10%			20%			30%			40-100%			
SNHX	0,12	0,28	0,71	0,08	0,20	0,51	0,06	0,15	0,38	0,06	0,13	0,33	0,05	0,12	0,30	SNHX

NOTE: Use "Light Machining" value as starting feed rate.

WIDIA™ M900™ Series •

Adjustable Slotting Cutters

The WIDIA M900 Series is a multipurpose slotting cutter with high-precision capability for numerous operations. The cutter is one of the most productive of its kind for slotting and for cut-off operations. Two keyways in the cutter provide wide slot options by mounting several cutters together in a gang-slotting style operation.



M900

Features

- Insert geometries and grades for various workpiece materials.
- Easy setting for desired width.
- Superior cartridge sliding mechanism.
- Available in arbour and shell mount.
- Two keyways for staggered slotting.
- Strong, reliable pocket seat.

Benefits

- Wide range of slot width options.
- High accuracy of slots.
- Security/stability of cartridge cutter.
- Wide range of mounting options.
- Multiple slots by gang slotting.

Application

- Full slotting.
- Half slotting (left and right styles).
- Gang slotting.
- Shoulder milling.
- Face milling.
- Back face milling.

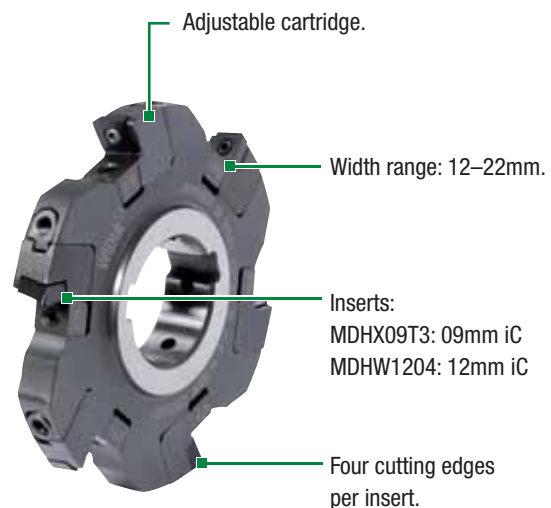

Slotting Mills



M900™

Slot Width Range:
12–22mm

Indexes per insert: 2
Diameter: 100–315mm

Pages: I10–I16, I18–I19



■ Insert Offering

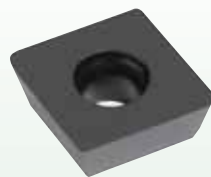

MDHX Geometry
iC 09mm

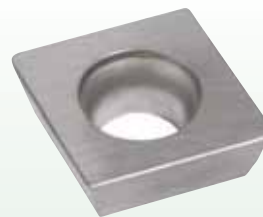

MDHW Geometry
iC 12mm

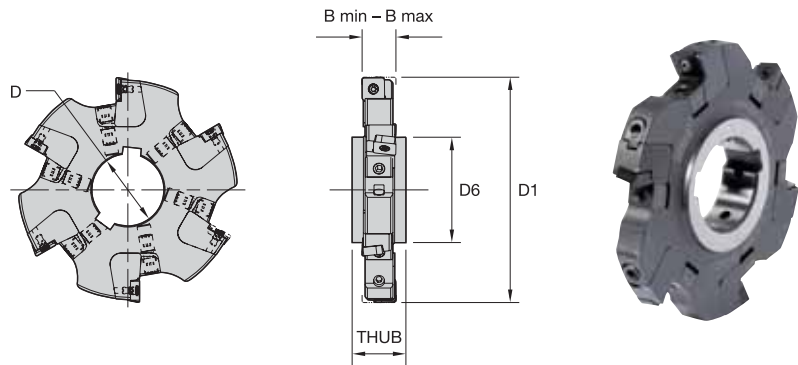
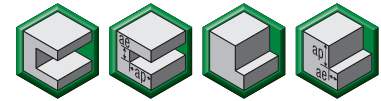

Slotting Mills

■ Arbour Mount • 9mm

order number	catalogue number	D1	D	D6	B min	B max	THUB	Z	max RPM	coolant supply	kg
2003598	12399010200	100	32	48	12	14	16,0	6	7070	No	0,5
2067540	12399011400	100	32	48	14	16	16,0	6	7070	No	0,8
2003695	12399010400	125	40	58	12	14	16,0	8	6370	No	0,8
2003696	12399011600	125	40	58	14	16	16,0	8	6370	No	0,9
2003697	12399012800	125	40	58	16	18	20,0	8	6370	No	1,1
2003796	12399011800	160	40	58	14	16	16,0	10	5600	No	1,6
2003797	12399013000	160	40	58	16	18	20,0	10	5600	No	1,9
2065591	12399010800	200	50	72	12	14	16,0	12	5040	No	2,1
2003879	12399012000	200	50	72	14	16	16,0	12	5040	No	2,6
2003880	12399013200	200	50	72	16	18	20,0	12	5040	No	2,9
2067541	12399013400	250	50	72	16	18	20,0	16	4480	No	7,0
2116241	12399013600	315	60	84	16	18	20,0	20	3990	No	7,6

■ Spare Parts

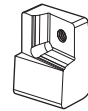

D1	insert screw	Torx driver	STC screw	T-handle hex wrench	clamp wedge	cartridge left-hand	cartridge right-hand	adjusting wedge left-hand	adjusting wedge right-hand
100	12148067200	12749726100	12148574100	12148050000	12748307600	12748210100	12748210200	12748551100	12748551200
100	12148067200	12749726100	12148574100	12148050000	12748307600	12748210300	12748210400	12748551100	12748551200
125	12148067200	12749726100	12148574100	12148050000	12748307600	12748210100	12748210200	12748551100	12748551200
125	12148067200	12749726100	12148574100	12148050000	12748307600	12748210300	12748210400	12748551100	12748551200
125	12148067200	12749726100	12148574100	12148050000	12748307700	12748210500	12748210600	12748551100	12748551200
160	12148067200	12749726100	12148574100	12148050000	12748307600	12748210300	12748210400	12748551100	12748551200
160	12148067200	12749726100	12148574100	12148050000	12748307700	12748210500	12748210600	12748551100	12748551200
200	12148067200	12749726100	12148574100	12148050000	12748307600	12748210100	12748210200	12748551100	12748551200
200	12148067200	12749726100	12148574100	12148050000	12748307600	12748210300	12748210400	12748551100	12748551200
200	12148067200	12749726100	12148574100	12148050000	12748307700	12748210500	12748210600	12748551100	12748551200
250	12148067200	12749726100	12148574100	12148050000	12748307700	12748210500	12748210600	12748551100	12748551200
315	12148067200	12749726100	12148574100	12148050000	12748307700	12748210500	12748210600	12748551100	12748551200

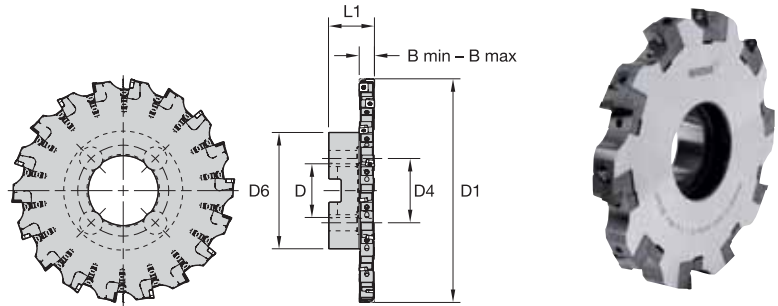
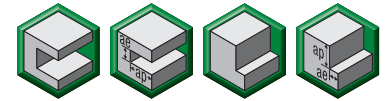

■ Shell Mount • 9mm

order number	catalogue number	D1	D	D4	D6	B min	B max	L1	Z	max RPM	coolant supply	kg
2003602	12399111400	100	27	—	48	14	16	33,0	6	7070	No	0,8
2003700	12399110400	125	32	—	58	12	14	37,0	8	6370	No	1,1
2003701	12399111600	125	32	—	58	14	16	37,0	8	6370	No	1,2
2003702	12399112800	125	32	—	58	16	18	37,0	8	6370	No	1,4
2003800	12399110600	160	40	—	70	12	14	42,0	10	5600	No	1,8
2003801	12399111800	160	40	—	70	14	16	42,0	10	5600	No	2,1
2003802	12399113000	160	40	—	70	16	18	42,0	10	5600	No	2,3
2003897	12399110800	200	40	67	90	12	14	44,0	12	5040	No	3,0
2003898	12399112000	200	40	67	90	14	16	44,0	12	5040	No	3,3
2003899	12399113200	200	40	67	90	16	18	44,0	12	5040	No	3,7
2003997	12399113400	250	60	102	130	16	18	50,0	16	4480	No	7,0
2004095	12399113600	315	60	102	130	16	18	50,0	20	3990	No	9,7

■ Spare Parts

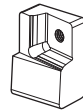

D1	insert screw	Torx driver	STC screw	T-handle hex wrench	clamp wedge	cartridge left-hand	cartridge right-hand	adjusting wedge left-hand	adjusting wedge right-hand
125	12148067200	12749726100	12148574100	12148050000	12748307600	12748210100	12748210200	12748551100	12748551200
100	12148067200	12749726100	12148574100	12148050000	12748307600	12748210300	12748210400	12748551100	12748551200
125	12148067200	12749726100	12148574100	12148050000	12748307600	12748210100	12748210200	12748551100	12748551200
125	12148067200	12749726100	12148574100	12148050000	12748307700	12748210500	12748210600	12748551100	12748551200
160	12148067200	12749726100	12148574100	12148050000	12748307600	12748210100	12748210200	12748551100	12748551200
160	12148067200	12749726100	12148574100	12148050000	12748307600	12748210300	12748210400	12748551100	12748551200
160	12148067200	12749726100	12148574100	12148050000	12748307700	12748210500	12748210600	12748551100	12748551200
200	12148067200	12749726100	12148574100	12148050000	12748307600	12748210100	12748210200	12748551100	12748551200
200	12148067200	12749726100	12148574100	12148050000	12748307600	12748210300	12748210400	12748551100	12748551200
200	12148067200	12749726100	12148574100	12148050000	12748307700	12748210500	12748210600	12748551100	12748551200
250	12148067200	12749726100	12148574100	12148050000	12748307700	12748210500	12748210600	12748551100	12748551200
315	12148067200	12749726100	12148574100	12148050000	12748307700	12748210500	12748210600	12748551100	12748551200

■ Insert Selection Guide

Material Group	Light Machining		General Purpose		Heavy Machining	
	Geometry	Grade	Geometry	Grade	Geometry	Grade
P1-P2	MDHX	WP40PM	MDHX	WP40PM	MDHX	WP40PM
P3-P4	MDHX	WP35CM	MDHX	WP35CM	MDHX	WP35CM
P5-P6	MDHX	WP35CM	MDHX	WP40PM	MDHX	WU35PM
M1-M2	MDHX	WP25PM	MDHX	WP25PM	MDHX	WU35PM
M3	MDHX	WP35CM	MDHX	WP40PM	MDHX	WU35PM
K1-K2	MDHX	WK15CM	MDHX	WK15CM	MDHX	WK15CM
K3	MDHX	WK15CM	MDHX	WP35CM	MDHX	WP35CM
N1-N2	-	-	-	-	-	-
N3	-	-	-	-	-	-
S1-S2	MDHX	WP25PM	MDHX	WU35PM	MDHX	WU35PM
S3	MDHX	WU35PM	MDHX	WU35PM	MDHX	WU35PM
S4	MDHX	WP25PM	MDHX	WU35PM	MDHX	WU35PM
H1	-	-	-	-	-	-

Slotting Mills

Inserts • MDHX..

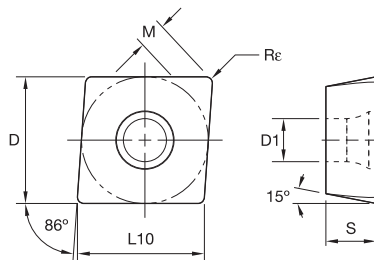
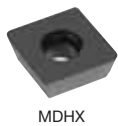

● first choice
○ alternate choice

P	●	●	●	●
M	●	●	○	●
K	●	○	○	○
N	○	○	○	○
S	●	●	○	○
H	○	○	○	○

■ MDHX

catalogue number	cutting edges	D	D1	L10	M	S	Rε	WK15CM	WP25PM	WU35PM	WP35CM	WP40PM
MDHX09T308	2	9,53	3,40	9,55	1,85	3,97	0,80	5903706	5903722	5903710	5903708	5903704

Recommended Starting Feeds

■ Recommended Starting Feeds [mm]

Light Machining	General Purpose	Heavy Machining
-----------------	-----------------	-----------------

Insert Geometry	Programmed Feed per Tooth (fz) as a % of Radial Depth of Cut (ae)														Insert Geometry	
	5%		10%		20%		30%		40-100%							
MDHX	0,12	0,23	0,46	0,08	0,17	0,33	0,06	0,13	0,25	0,06	0,11	0,22	0,05	0,10	0,20	MDHX

NOTE: Use "Light Machining" value as starting feed rate.

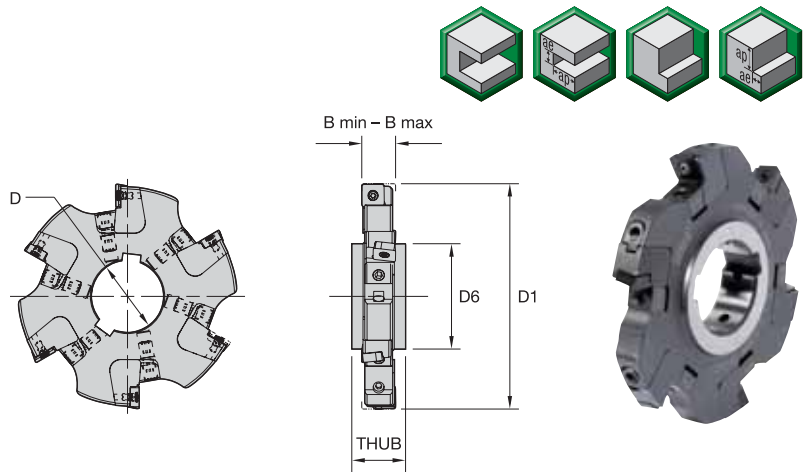

■ **Arbour Mount • 12mm**

order number	catalogue number	D1	D	D6	B min	B max	THUB	Z	max RPM	coolant supply	kg
2003881	12399014400	200	50	72	18	20	20,0	12	5040	No	3,2
2003882	12399015600	200	50	72	20	22	24,0	12	3990	No	3,7
2003993	12399014600	250	50	72	18	20	20,0	16	4480	No	5,1
2003994	12399015800	250	50	72	20	22	24,0	16	3570	No	5,9
2004081	12399014800	315	60	84	18	20	20,0	20	3990	No	8,1
2004082	12399016000	315	60	84	20	22	24,0	20	3220	No	9,4

■ **Spare Parts**

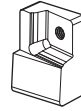

D1	insert screw	Torx driver	STC screw	T-handle hex wrench	clamp wedge	cartridge left-hand	cartridge right-hand	adjusting wedge left-hand	adjusting wedge right-hand
200	12748605300	12749723200	12148574100	12148050000	12748307700	12748210700	12748210800	12748551100	12748551200
200	12748605300	12749723200	12148574100	12148050000	12748307800	12748210900	12748211000	12748551100	12748551200
250	12748605300	12749723200	12148574100	12148050000	12748307700	12748210700	12748210800	12748551100	12748551200
250	12748605300	12749723200	12148574100	12148050000	12748307800	12748210900	12748211000	12748551100	12748551200
315	12748605300	12749723200	12148574100	12148050000	12748307700	12748210700	12748210800	12748551100	12748551200
315	12748605300	12749723200	12148574100	12148050000	12748307800	12748210900	12748211000	12748551100	12748551200

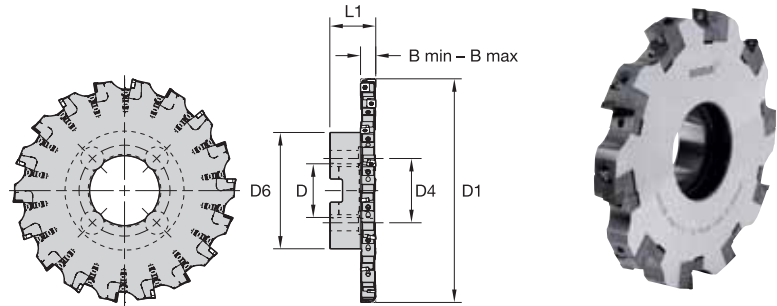
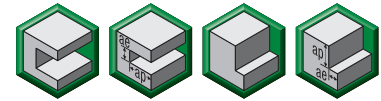

Slotting Mills

■ Shell Mount • 12mm

order number	catalogue number	D1	D	D4	D6	B min	B max	L1	Z	max RPM	coolant supply	kg
2003900	12399114400	200	40	67	90	18	20	44,8	12	5040	No	3,8
2003901	12399115600	200	40	67	90	20	22	46,0	12	3990	No	4,3
2003998	12399114600	250	60	102	130	18	20	51,8	16	4480	No	7,2
2003999	12399115800	250	60	102	130	20	22	53,0	16	3570	No	7,9
2004096	12399114800	315	60	102	130	18	20	51,8	20	3990	No	10,2
2004097	12399116000	315	60	102	130	20	22	53,0	20	3220	No	11,3

■ Spare Parts

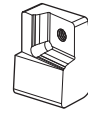

D1	insert screw	Torx driver	STC screw	T-handle hex wrench	clamp wedge	cartridge left-hand	cartridge right-hand	adjusting wedge left-hand	adjusting wedge right-hand
200	12748605300	12749723200	12148574100	12148050000	12748307700	12748210700	12748210800	12748551100	12748551200
200	12748605300	12749723200	12148574100	12148050000	12748307800	12748210900	12748211000	12748551100	12748551200
250	12748605300	12749723200	12148574100	12148050000	12748307700	12748210700	12748210800	12748551100	12748551200
250	12748605300	12749723200	12148574100	12148050000	12748307800	12748210900	12748211000	12748551100	12748551200
315	12748605300	12749723200	12148574100	12148050000	12748307700	12748210700	12748210800	12748551100	12748551200
315	12748605300	12749723200	12148574100	12148050000	12748307800	12748210900	12748211000	12748551100	12748551200

■ **Insert Selection Guide**

Material Group	Light Machining		General Purpose		Heavy Machining	
	Geometry	Grade	Geometry	Grade	Geometry	Grade
P1-P2	MDHW	WP40PM	MDHW	WP40PM	MDHW	WP40PM
P3-P4	MDHW	WP35CM	MDHW	WP35CM	MDHW	WP35CM
P5-P6	MDHW	WP35CM	MDHW	WP40PM	MDHW	WU35PM
M1-M2	MDHW	WP25PM	MDHW	WP25PM	MDHW	WU35PM
M3	MDHW	WP35CM	MDHW	WP40PM	MDHW	WU35PM
K1-K2	MDHW	WK15CM	MDHW	WK15CM	MDHW	WK15CM
K3	MDHW	WK15CM	MDHW	WP35CM	MDHW	WP35CM
N1-N2	-	-	-	-	-	-
N3	-	-	-	-	-	-
S1-S2	MDHW	WP25PM	MDHW	WU35PM	MDHW	WU35PM
S3	MDHW	WU35PM	MDHW	WU35PM	MDHW	WU35PM
S4	MDHW	WP25PM	MDHW	WU35PM	MDHW	WU35PM
H1	-	-	-	-	-	-

Slotting Mills

Inserts • MDH..

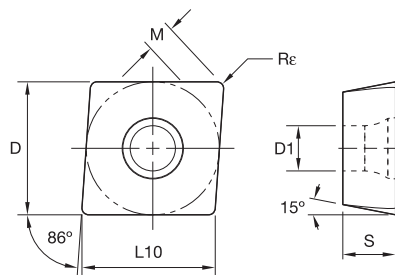
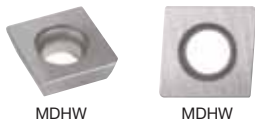

● first choice
○ alternate choice

P	●	●	●	●	●
M	●	●	○	○	●
K	●	○	○	○	○
N	○	○	○	○	○
S	○	○	○	○	○
H	○	○	○	○	○

■ **MDHW**

catalogue number	cutting edges	D	D1	L10	M	S	Rε	5903707	5903723	5903721	5903709	5903705
MDHW120408	2	12,70	5,50	12,73	2,58	4,76	0,80	●	○	○	○	○

■ Recommended Starting Speeds [m/min]

Material Group		WK15CM			WP25PM			WU35PM			WP35CM			WP40PM		
P	0	-	-	-	330	285	270	260	230	215	455	395	370	295	260	245
	1	-	-	-	330	285	270	260	230	215	455	395	370	295	260	245
	2	-	-	-	275	240	200	220	190	160	280	255	230	250	215	180
	3	-	-	-	255	215	175	200	170	140	255	230	205	230	195	160
	4	-	-	-	225	185	150	180	150	120	190	175	160	205	170	135
	5	-	-	-	185	170	150	150	135	120	260	230	210	170	155	135
	6	-	-	-	165	125	100	130	100	80	160	135	110	150	115	90
M	1	-	-	-	205	180	165	170	150	135	205	185	155	195	170	155
	2	-	-	-	185	160	130	155	130	110	185	160	140	175	150	125
	3	-	-	-	140	120	95	115	100	80	145	130	115	130	115	90
K	1	420	385	340	230	205	185	-	-	-	295	265	240	-	-	-
	2	335	295	275	180	160	150	-	-	-	235	210	190	-	-	-
	3	280	250	230	150	135	120	-	-	-	195	175	160	-	-	-
N	1	-	-	-	-	-	-	-	-	-	-	-	-	-	-	-
	2	-	-	-	-	-	-	-	-	-	-	-	-	-	-	-
	3	-	-	-	-	-	-	-	-	-	-	-	-	-	-	-
S	1	-	-	-	40	35	25	35	30	25	-	-	-	40	35	30
	2	-	-	-	40	35	25	35	30	25	-	-	-	40	35	30
	3	-	-	-	50	40	25	45	35	25	-	-	-	50	40	30
	4	-	-	-	70	50	35	60	45	30	66	50	33	65	50	35
H	1	-	-	-	-	-	-	-	-	-	-	-	-	-	-	-
	2	-	-	-	-	-	-	-	-	-	-	-	-	-	-	-
	3	-	-	-	-	-	-	-	-	-	-	-	-	-	-	-

NOTE: FIRST choice starting speeds are in **bold** type.
As the average chip thickness increases, the speed should be decreased.

Recommended Starting Feeds

■ Recommended Starting Feeds [mm]

Light Machining	General Purpose	Heavy Machining
-----------------	-----------------	-----------------

Insert Geometry	Programmed Feed per Tooth (fz) as a % of Radial Depth of Cut (ae)															Insert Geometry
	5%			10%			20%			30%			40-100%			
MDHW	0,12	0,23	0,46	0,08	0,17	0,33	0,06	0,13	0,25	0,06	0,11	0,22	0,05	0,10	0,20	MDHW

NOTE: Use "Light Machining" value as starting feed rate.



WIDIA™ Knowledge Center



EXTREME **CHALLENGES.**
EXTREME **RESULTS.**

Classes to Suit Everyone

Doing things the same way year after year can stall productivity. Continuing education and training in the latest machining practices are necessary to stay competitive.

The Knowledge Center offers several ways to get trained: industry- and application-specific courses, customer onsite programs, and online-based certified metalcutting professional courses. In-person classes include lecture, lab, and machining demonstrations.

Regional Training

The Regional Application Engineering Program is designed to provide a broad base of knowledge for the selection and use of metalcutting tools. Instruction includes lecture-style presentations and video demonstrations. Participants receive notes and text materials, and the video demonstrations reinforce the theories presented in the lecture.

Metalcutting Application Training

The Comprehensive Metalworking Application Course provides a broad base of knowledge for the selection and use of metalcutting tools. Lecture-style presentations and laboratory demonstrations enhance course material through actual cutting tests and reinforce the theories presented in the lecture.

For more information, contact your local WIDIA
Authorised Distributor or visit widia.com/services.

WIDIA 

■ Assembly and Operating Instructions

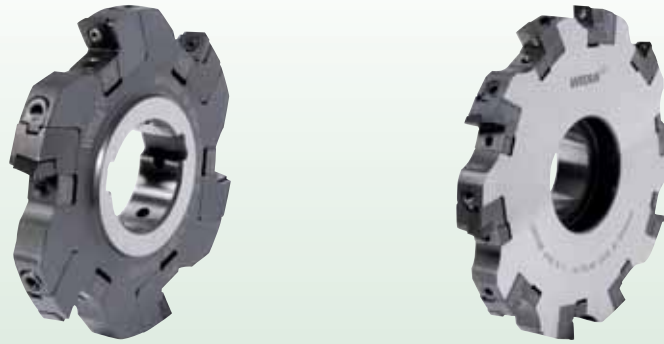

1. General

The runout tolerance of the milling cutter has a decisive effect on the quality of workpieces and the life cycle of tools. Proper tool fitting and the precise axial setting of the milling insert are essential for a successful application and optimum results. One key requirement for assembly and setting work is that all components are clean. Bearing surfaces must be free from grease, and only the threads of indexable insert clamping screws and double threaded screws of clamping and adjusting wedges should be lubricated with copper grease. The indexable inserts should be inserted in the cleaned insert seats so that they are positioned correctly on the bearing surfaces. The indexable insert clamping screws should be tightened with the specified torque.

2. Exploded Diagram of Spare Parts

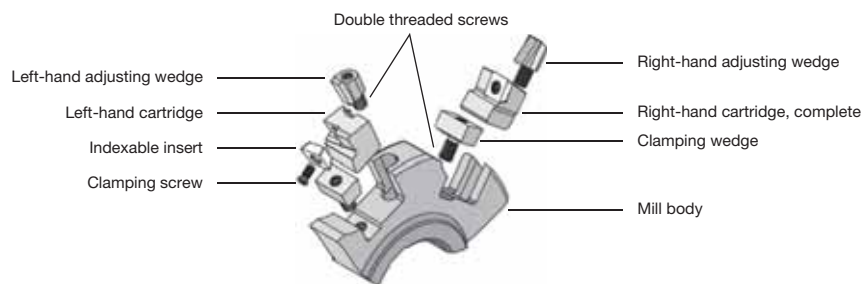

3. Mounting the Cartridges in the Mill Body

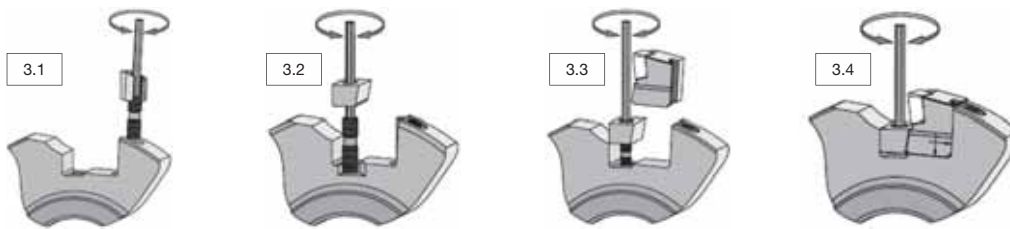

3.1 Turn double threaded screw one turn clockwise in the adjusting wedge. Then insert both parts in the slot in the mill body and turn the double threaded screw clockwise until the adjusting wedge is flush with the milling cutter.

3.2 Turn double threaded screw three turns clockwise in the mill body. Then mount the clamping wedge on the double threaded screw and screw both parts together until the lower edge of the clamping wedge is at the same height as the chip space runout.

3.3 Push the top of the fully assembled cartridge into the mill body using the rear bearing surface of the milling cutter so that the cartridge slot makes contact with the adjusting wedge spring. Ensure a perfect axial/radial surface.

3.4 Secure the correctly positioned cartridge by tightening the clamping wedge with a preset torque of $MA_{pre} = 1 \text{ Nm}$ to set the runout or cutting width.

4. Setting the Runout for Milling Cutters with 2–3 Cutting Edges

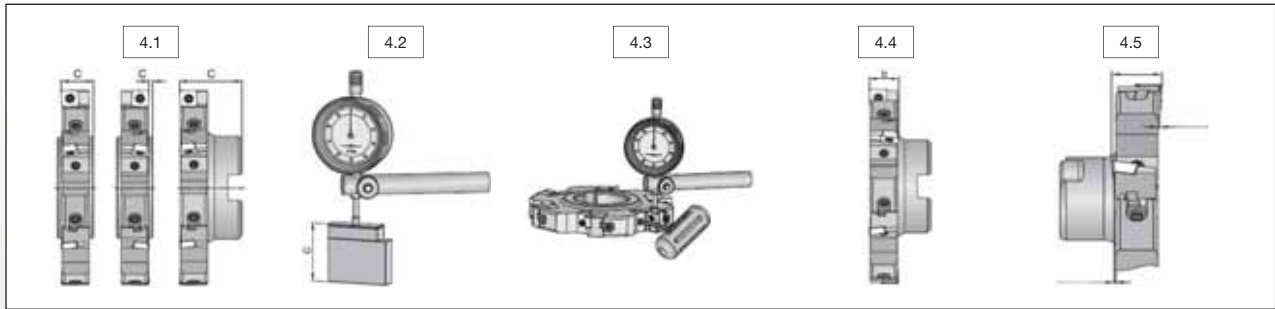

- 4.1 Possible interpretations of the measuring dimension C.
- 4.2 Set gage to desired measurement C using gage blocks set to 0.
- 4.3 Set cartridge to -0,1mm before final measurement. Clamping wedge is tightened with torque $MA_{pre} = 1 \text{ Nm}$. Then briefly loosen clamping wedge and tighten again.
- 4.4 Set cartridge to 0,02mm before final measurement. Then briefly loosen clamping wedge so that the contact surfaces can level out. Tighten clamping.
- 4.4 Wedge again with torque $MA_{pre} = 1 \text{ Nm}$.
- 4.5 Adjust cartridge to final measurement. Tighten clamping wedge with torque $MA = 4 \text{ Nm}$. Check runout of the fully adjusted milling cutter.

5. Setting the Runout for Milling Cutters with 3 Cutting Edges

The cutting widths for milling cutters with three cutting edges are set using purpose-designed optical tool presetting equipment. Note that the projection of the cartridges from the mill body must be almost exactly the same on both sides. The sequence of steps required for setting the cartridge is identical to those for tools with two cutting edges.

ATTENTION:

At each tool adjustment, the body, cartridges, indexable inserts, and spare parts must be checked and replaced if necessary. Before each tool use, the clamping and double threaded screws must be tightened with the specified torque. The tools must only be used in accordance with their function. We accept no liability for their improper use. Changes of any kind and/or printing errors are not valid grounds for claims.



Indexable Milling • Copy Mills

M370 • High-Feed Double-Sided Platform.....	J2–J16
M200 • Double-Sided Round Inserts	J18–J39
M100 • Positive Round Inserts.....	J40–J67
M270 • Indexable Ball Nose and Toroidal Inserts for Complex Parts	J68–J98



High-Feed Applications •
M370™ Series

M370



Designed for high feed rate productivity, M370 Series provides the latest insert technology with outstanding performance and reliability. Its double-sided concept and six cutting edges provide security and optimal metal removal with an efficient cost per edge.

- Double-sided design offers six cutting edges per insert.
- Extremely high metal removal rates.
- First choice for high-feed roughing applications.

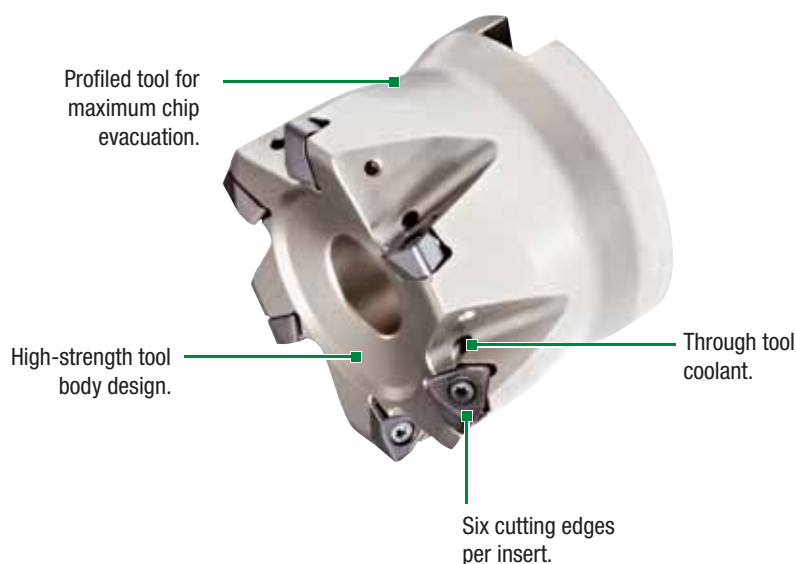

Copy Mills



M370™

Max depth of cut: up to 2mm

Indexes per insert: 6
Diameter: 25–125mm

Pages: J4–J16

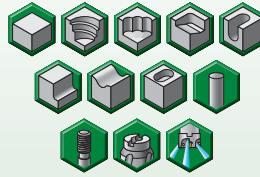
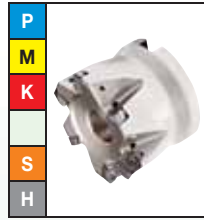

■ **Insert Offering**

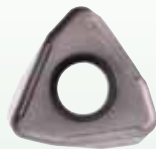

8mm iC Insert WOEJ0804
Up to 1,3mm A_p max
Diameter range 25–80mm



12mm iC Insert WOEJ1207
Up to 2mm A_p max
Diameter range 42–125mm

- Double-sided, six cutting edges.
- Highest metal removal rates.
- First choice for roughing applications.

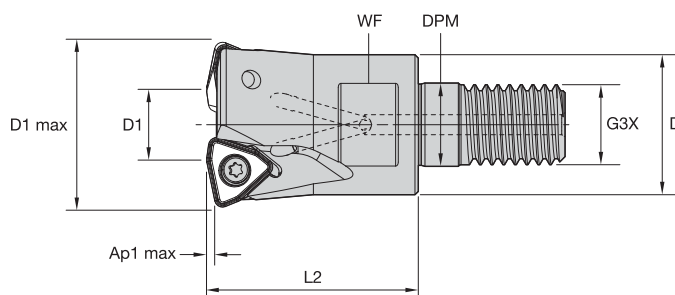
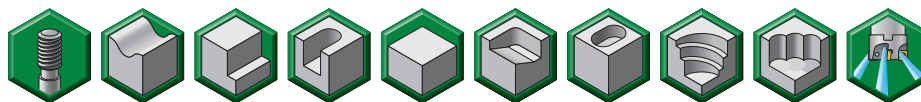

■ Screw-On End Mills

order number	catalogue number	D1 max	D1	D	DPM	G3X	L2	WF	Ap1 max	Z	max ramp angle	max RPM	coolant supply	kg
4056186	M370D025Z02M12WO08	25	11	21	12,5	M12	35	17	1,3	2	2.1°	46000	Yes	0,09
4170918	M370D025Z03M12WO08	25	11	21	12,5	M12	35	17	1,3	3	2.1°	46000	Yes	0,09
4056187	M370D032Z04M16WO08	32	18	29	17,0	M16	43	24	1,3	4	1.4°	38700	Yes	0,21
4056188	M370D042Z05M16WO08	42	28	29	17,0	M16	43	24	1,3	5	1.0°	32500	Yes	0,57

■ Spare Parts

D1 max	insert screw	Nm	Torx driver
25	MS2219	1,8	DT9IP
32	MS2219	1,8	DT9IP
42	MS2219	1,8	DT9IP

Copy Mills

- Double-sided, six cutting edges.
- Highest metal removal rates.
- First choice for roughing applications.

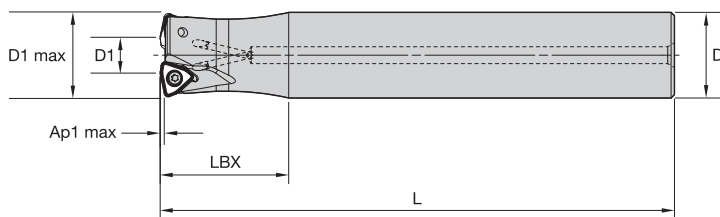
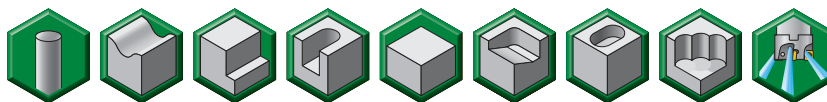

■ Cylindrical End Mills

order number	catalogue number	D1 max	D1	D	L	LBX	Ap1 max	Z	max RPM	coolant supply	kg
4056189	M370D025Z03A25WO08L150	25	11	25	150	40	1,3	3	46000	Yes	0,50
4008281	M370D025Z02A25WO08L200	25	11	25	200	50	1,3	2	46000	Yes	0,68
4170919	M370D025Z03A25WO08L200	25	11	25	200	40	1,3	3	46000	Yes	0,69
4170920	M370D025Z02A25WO08L300	25	11	25	300	40	1,3	2	46000	Yes	1,08
4056190	M370D028Z03A25WO08L200	28	14	25	200	40	1,3	3	42400	Yes	0,70
4056192	M370D032Z04A32WO08L200	32	18	32	200	50	1,3	4	38700	Yes	1,14
4056191	M370D032Z04A32WO08L150	32	18	32	150	40	1,3	4	38700	Yes	0,84
4170921	M370D032Z03A32WO08L300	32	18	32	300	40	1,3	3	38700	Yes	1,77

■ Spare Parts



D1 max	insert screw	Nm	wrench
25	MS2219	1,8	DT9IP
28	MS2219	1,8	DT9IP
32	MS2219	1,8	DT9IP

Copy Mills

- Double-sided, six cutting edges.
- Highest metal removal rates.
- First choice for roughing applications.

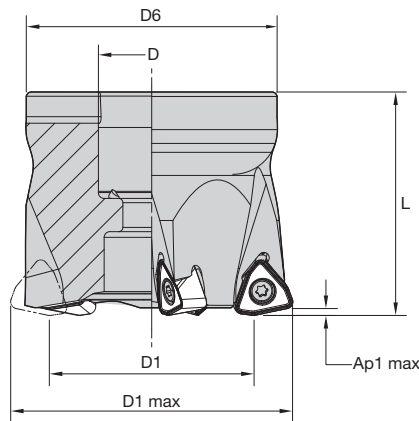
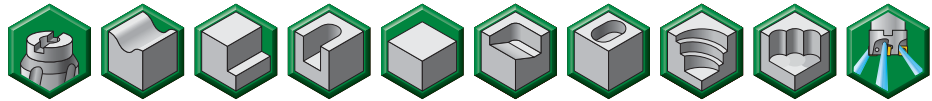

Copy Mills

■ Shell Mills

order number	catalogue number	D1 max	D1	D	D6	L	Ap1 max	Z	max RPM	coolant supply	kg
4056193	M370D040Z04WO08	40	26	16	37	40	1,3	4	33500	Yes	0,19
4170922	M370D040Z05WO08	40	26	16	37	40	1,3	5	33500	Yes	0,19
4008276	M370D050Z05WO08	50	36	22	44	40	1,3	5	29200	Yes	0,29
4171223	M370D050Z06WO08	50	36	22	44	40	1,3	6	29200	Yes	0,29
4171224	M370D052Z06WO08	52	38	22	44	50	1,3	6	28600	Yes	0,40
4056194	M370D052Z05WO08	52	38	22	44	50	1,3	5	28600	Yes	0,41
4056195	M370D063Z06WO08	63	49	22	60	50	1,3	6	25500	Yes	0,74
4008277	M370D066Z06WO08	66	52	27	60	50	1,3	6	24900	Yes	0,77
4171225	M370D080Z07WO08	80	66	27	60	50	1,3	7	24900	Yes	2,36

■ Spare Parts



D1 max	insert screw	Nm	Torx Plus driver	socket-head cap screw	socket-head cap screw with coolant groove
40	MS2219	1,8	DT9IP	125.825	MS1294CG
50	MS2219	1,8	DT9IP	12146120500	MS1234CG
52	MS2219	1,8	DT9IP	12146120500	MS1234CG
63	MS2219	1,8	DT9IP	12146120500	MS1234CG
66	MS2219	1,8	DT9IP	MS2038	MS2038CG
80	MS2219	1,8	DT9IP	MS2038	MS2038CG

NOTE: Socket-head cap screw with coolant groove must be ordered separately.

Insert Selection Guide

Material Group	Light Machining		General Purpose		Heavy Machining	
	Geometry	Grade	Geometry	Grade	Geometry	Grade
P1-P2	..MM	WP40PM	..MM	WP40PM	..MM	WP40PM
P3-P4	..MM	WP25PM	..MM	WP40PM	..MH	WP40PM
P5-P6	..MM	WP25PM	..MH	WP25PM	..MH	WP40PM
M1-M2	..MM	WP25PM	..MM	WS30PM	..MM	WP40PM
M3	..MM	WP25PM	..MM	WP25PM	..MM	WP40PM
K1-K2	..MH	WK15CM	..MH	WK15CM	..MH	WK15CM
K3	..MH	TN6520	..MH	TN6520	..MH	WK15CM
N1-N2	-	-	-	-	-	-
N3	-	-	-	-	-	-
S1-S2	..MM	WP25PM	..MM	WS30PM	..MM	WP40PM
S3	..MM	WS30PM	..MM	WS30PM	..MM	WP40PM
S4	..MM	WS30PM	..MM	WP40PM	..MM	WP40PM
H1	..MH	WP25PM	-	-	-	-

iC08 • Inserts • W0.J0804...

Copy Mills

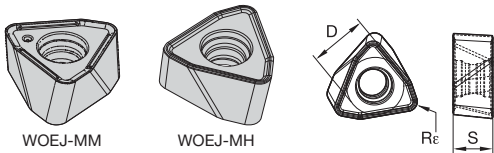

- -MM geometry provides lower cutting forces. First choice for steel, stainless steel, and high-temp alloys.
- -MH geometry is the first choice for high-strength steel and cast iron.

● first choice
○ alternate choice

P	●	○	○	○	○	○	○	○	○
M	●	○	○	○	○	○	○	○	○
K	●	○	○	○	○	○	○	○	○
N	○	○	○	○	○	○	○	○	○
S	○	○	○	○	○	○	○	○	○
H	○	○	○	○	○	○	○	○	○

WOEJ-MM

catalogue number	cutting edges	D	S	Re	TN6520	TN6525	TN7535	WK15CM	WP25PM	WS30PM	WP40PM
WOEJ080412SRMM	6	7,79	4,70	1,22	○	○	○	○	○	○	○

WOEJ-MH

catalogue number	cutting edges	D	S	Re	TN6520	TN6525	TN7535	WK15CM	WP25PM	WS30PM	WP40PM
WOEJ080412SRMH	6	7,79	4,75	1,22	○	○	○	○	○	○	○

■ Recommended Starting Speeds [m/min]

Material Group		TN6520			TN6525			TN7535			WK15CM		
P	1	-	-	-	410	320	280	545	475	445	-	-	-
	2	-	-	-	320	250	215	335	305	275	-	-	-
	3	-	-	-	280	215	185	305	275	245	-	-	-
	4	-	-	-	235	170	145	230	210	190	-	-	-
	5	-	-	-	310	235	200	310	275	250	-	-	-
	6	-	-	-	205	160	130	190	160	130	-	-	-
M	1	-	-	-	190	120	80	245	220	185	-	-	-
	2	-	-	-	120	80	50	220	190	170	-	-	-
	3	-	-	-	125	80	55	175	155	140	-	-	-
K	1	450	320	230	275	245	220	355	320	290	505	460	410
	2	390	250	190	215	190	180	280	250	230	400	355	330
	3	300	230	160	180	160	145	235	210	190	335	300	275
N	1	-	-	-	-	-	-	-	-	-	-	-	-
	2	-	-	-	-	-	-	-	-	-	-	-	-
	3	-	-	-	-	-	-	-	-	-	-	-	-
S	1	-	-	-	-	-	-	-	-	-	-	-	-
	2	-	-	-	-	-	-	-	-	-	-	-	-
	3	-	-	-	-	-	-	-	-	-	-	-	-
	4	-	-	-	-	-	-	-	-	-	-	-	-
H	1	-	-	-	-	-	-	-	-	-	-	-	-
	2	-	-	-	-	-	-	-	-	-	-	-	-
	3	-	-	-	-	-	-	-	-	-	-	-	-

(continued)

Copy Mills

(Recommended Starting Speeds [m/min] – continued)

Material Group		WP25PM			WS30PM			WP40PM		
P	1	395	340	325	-	-	-	355	310	295
	2	330	290	240	-	-	-	300	260	215
	3	305	260	210	-	-	-	275	235	190
	4	270	220	180	-	-	-	245	205	160
	5	220	205	180	-	-	-	205	185	160
	6	200	150	120	-	-	-	180	140	110
M	1	245	215	200	270	240	220	235	205	185
	2	220	190	155	245	215	175	210	180	150
	3	170	145	115	185	160	125	155	140	110
K	1	275	245	220	-	-	-	-	-	-
	2	215	190	180	-	-	-	-	-	-
	3	180	160	145	-	-	-	-	-	-
N	1	-	-	-	-	-	-	-	-	-
	2	-	-	-	-	-	-	-	-	-
	3	-	-	-	-	-	-	-	-	-
S	1	50	40	30	55	50	35	50	40	35
	2	50	40	30	55	50	35	50	40	35
	3	60	50	30	65	55	35	60	50	35
	4	85	60	40	100	70	50	80	60	40
H	1	145	110	85	-	-	-	-	-	-
	2	-	-	-	-	-	-	-	-	-
	3	-	-	-	-	-	-	-	-	-

NOTE: FIRST choice starting speeds are in **bold** type.
As the average chip thickness increases, the speed should be decreased.

Copy Mills

Recommended Starting Feeds

■ Recommended Starting Feeds [mm]

Light Machining	General Purpose	Heavy Machining
-----------------	-----------------	-----------------

For Plunging Applications

Insert Geometry	Programmed Feed per Tooth (fz) as a % of Radial Depth of Cut (ae)															Insert Geometry
	5%			10%			20%			30%			40-100%			
..MM	0,90	1,67	4,09	0,65	1,19	2,83	0,48	0,88	2,08	0,42	0,77	1,80	0,38	0,70	1,64	..MM
..MH	0,90	2,34	5,00	0,65	1,66	3,41	0,48	1,23	2,49	0,42	1,07	2,16	0,38	0,98	1,97	..MH

NOTE: Use "Light Machining" value as starting feed rate.

Applying High-Feed Tools

The high-feed concept bases its strategy on small depth of cut and higher fz values, which results in a higher MRR and productivity with low radial forces.

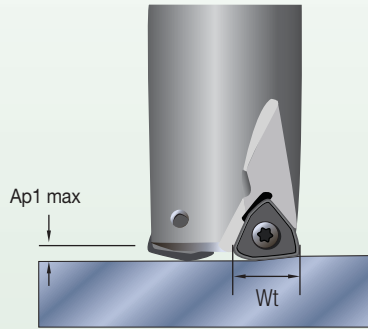

Small Ap1 values and higher feed rates generate lower cutting forces versus traditional milling strategies.

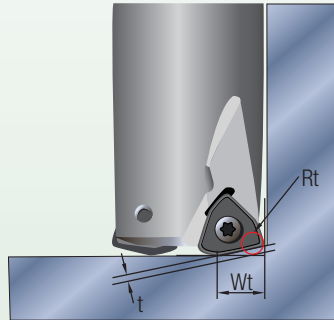

For CAM programming, the tools can be programmed as a toroidal tool type by using the Rt value as the insert radius.

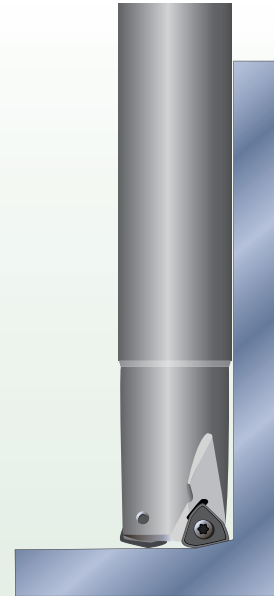

Recommended when long overhang is necessary due to lower radial forces. Maximum L/D ratio of 10 x D.

General Programming Information for Applying M370

L/D ratio	starting Ap1	starting fz range
<3	0,9mm	1-1,3mm
>3-5	0,6mm	1-1,3mm
>5-7	0,4mm	0,6-1mm

Rt	t	Wt
2,5mm	1mm	7,5mm

Maximum Linear Ramping and Helical Interpolation from Solid • Metric

cutter diameter	max linear ramp angle (straight line)	min hole diameter	max hole diameter	Ap1 max per revolution
25	3,1°	30,2	49,5	1,25
28	2,6°	36,1	55,5	1,25
32	2,9°	44,1	63,5	1,25
40	1,6°	60	79,5	1,25
42	1,5°	64	83,5	1,25
50	1,3°	80	99,5	1,25
52	1,2°	84	103,5	1,25
63	1°	106	125,5	1,25
66	1°	112	131,5	1,25
80	0,8°	140	155,5	1,25

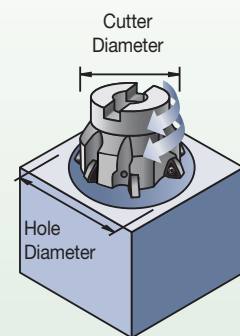

- Double-sided, six cutting edges.
- Highest metal removal rates.
- First choice for roughing applications.

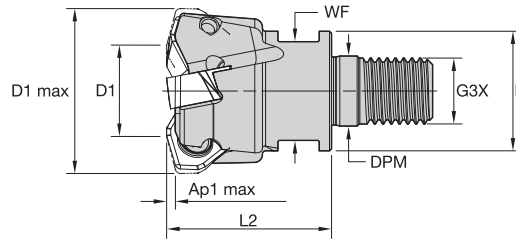
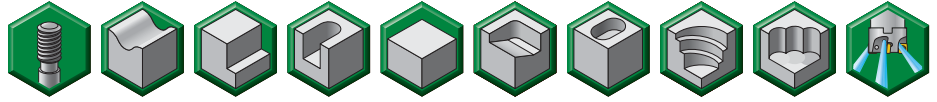

■ **Screw-On End Mills**

order number	catalogue number	D1 max	D1	D	DPM	G3X	L2	WF	Ap1 max	Z	max ramp angle	max RPM	coolant supply	kg
5338912	M370D42Z03M16WO12	42	25	29	17,0	M16	40	24	2,0	3	5.1°	21310	Yes	0,22

■ **Spare Parts**

			
	insert screw	Nm	Torx driver
D1 max	MS2085	4,0	DT15IP
42			

Copy Mills

- Double-sided, six cutting edges.
- Highest metal removal rates.
- First choice for roughing applications.

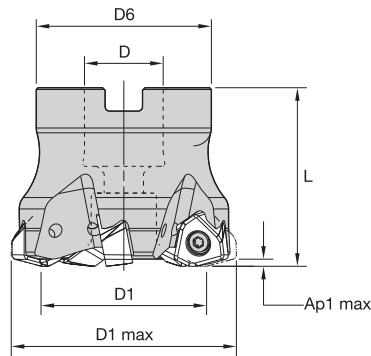
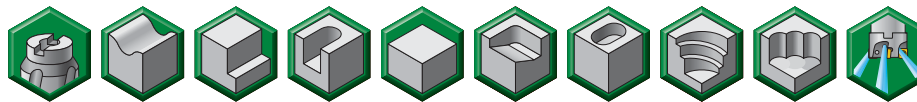

■ Shell Mills

order number	catalogue number	D1 max	D1	D	D6	L	Ap1 max	Z	max RPM	coolant supply	kg
5338913	M370D50Z04WO12	50,0	33	22	42	50	2,0	4	19530	Yes	0,38
5338914	M370D52Z04WO12	52,0	35	22	49	50	2,0	4	19160	Yes	0,47
5338915	M370D63Z04WO12	63,0	46	22	49	50	2,0	4	17400	Yes	0,57
5338916	M370D63Z05WO12	63,0	46	22	49	50	2,0	5	17400	Yes	0,57
5338917	M370D66Z05WO12	66,0	49	27	60	50	2,0	5	17000	Yes	0,79
5338918	M370D80Z05WO12	80,0	63	27	60	50	2,0	5	15440	Yes	0,94
5338919	M370D80Z06WO12	80,0	63	27	60	50	2,0	6	15440	Yes	0,94
5338920	M370D100Z06WO12	100,0	83	32	78	50	2,0	6	13810	Yes	1,56
5338921	M370D100Z07WO12	100,0	83	32	78	50	2,0	7	13810	Yes	1,57
5338922	M370D125Z07WO12	125,0	108	40	90	63	2,0	7	12350	Yes	2,92
5338923	M370D125Z09WO12	125,0	108	40	90	63	2,0	9	12350	Yes	2,94

■ Spare Parts

D1 max	insert screw	Nm	Torx Plus driver	socket-head cap screw	socket-head cap screw with coolant groove	coolant lock screw	coolant lock screw assembly
50	MS2085	4,0	DT15IP	12146120500	MS1234CG	—	—
52	MS2085	4,0	DT15IP	12146120500	MS1234CG	—	—
63	MS2085	4,0	DT15IP	125.025	MS1234CG	—	—
66	MS2085	4,0	DT15IP	125.230	MS2038CG	—	—
80	MS2085	4,0	DT15IP	125.230	MS2038CG	—	—
100	MS2085	4,0	DT15IP	—	—	KLS32M	MS2195C
125	MS2085	4,0	DT15IP	—	—	KLS40M	MS2187C

NOTE: Socket-head cap screw with coolant groove and coolant lock screw assembly must be ordered separately.

Insert Selection Guide

Material Group	Light Machining		General Purpose		Heavy Machining	
	Geometry	Grade	Geometry	Grade	Geometry	Grade
P1-P2	.S..MM	WU35PM	.S..MM	WP40PM	.S..MM	WP40PM
P3-P4	.S..MM	WP25PM	.S..MM	WP25PM	.S..MH	WP40PM
P5-P6	.S..MM	WP25PM	.S..MM	WP35CM	.S..MH	WP35CM
M1-M2	.S..MM	WS30PM	.S..MM	WU35PM	.S..MM	WP40PM
M3	.S..MM	WP25PM	.S..MM	WP35CM	.S..MM	WP40PM
K1-K2	.S..MH	WK15CM	.S..MH	WK15CM	.S..MH	WP20CM
K3	.S..MH	WK15CM	.S..MH	WK15CM	.S..MH	WP20CM
N1-N2	-	-	-	-	-	-
N3	-	-	-	-	-	-
S1-S2	.S..MM	WS30PM	.S..MM	WU35PM	.S..MM	WP40PM
S3	.S..MM	WS30PM	.S..MM	WU35PM	.S..MM	WP40PM
S4	.S..MM	WS30PM	.S..MM	WU35PM	.S..MM	WP40PM
H1	.S..MH	WP35CM	.S..MR	WP25PM	-	-

iC12 • Inserts • WO.J1207...

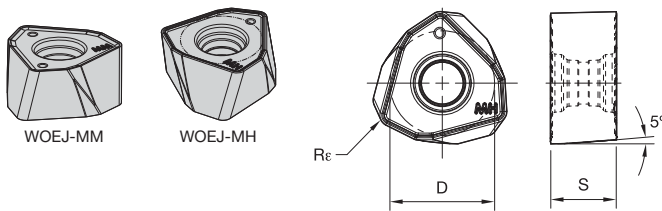

- MM geometry provides lower cutting forces. First choice for steel, stainless steel, and high-temp alloys.
- MH geometry is the first choice for high-strength steel and cast iron.
- MR geometry is designed for heavy-duty steel and cast iron applications.

● first choice
○ alternate choice

P	●	●	●	●	●	●	●
M	○	○	○	○	○	○	○
K	●	○	○	○	○	○	○
N	○	○	○	○	○	○	○
S	○	○	○	○	○	○	○
H	○	○	○	○	○	○	○

WOEJ-MM

catalogue number	cutting edges	D	S	Rε	WK15CM	WP20CM	WP25PM	WU35PM	WP35CM	WS30PM	WP40PM
WOEJ120712SRMM	6	12,00	7,30	1,27	○	○	○	○	○	○	○

WOEJ-MH

catalogue number	cutting edges	D	S	Rε	WK15CM	WP20CM	WP25PM	WU35PM	WP35CM	WS30PM	WP40PM
WOEJ120712SRMH	6	12,00	7,30	1,27	○	○	○	○	○	○	○



WOEJ-MR

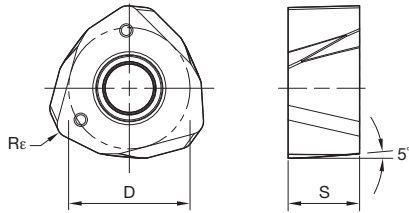

● first choice
○ alternate choice

P	●	●	●	●	●	●	●
M	○	○	○	○	○	○	○
K	○	○	○	○	○	○	○
N							
S	○	○	○	○	○	○	○
H							

■ WOEJ-MR

catalogue number	cutting edges	D	S	Rε	WK15CM	WP20CM	WP25PM	WU35PM	WP35CM	WS30PM	WP40PM
WOEJ120712SRMR	6	12,00	7,30	1,27	●	○	○	○	○	○	○

Copy Mills

Recommended Starting Speeds

■ Recommended Starting Speeds [m/min]

Material Group		WK15CM			WP20CM			WP25PM			WU35PM		
P	1	-	-	-	660	580	540	395	340	325	310	275	260
	2	-	-	-	410	370	330	330	290	240	265	230	190
	3	-	-	-	370	330	305	305	260	210	240	205	170
	4	-	-	-	275	260	230	270	220	180	215	180	145
	5	-	-	-	330	300	275	220	205	180	180	160	145
	6	-	-	-	230	205	175	200	150	120	155	120	95
M	1	-	-	-	270	240	210	245	215	200	205	180	160
	2	-	-	-	245	210	190	220	190	155	185	155	130
	3	-	-	-	190	175	150	170	145	115	140	120	95
K	1	505	460	410	430	390	355	275	245	220	-	-	-
	2	400	355	330	340	305	280	215	190	180	-	-	-
	3	335	300	275	290	260	240	180	160	145	-	-	-
N	1	-	-	-	-	-	-	-	-	-	-	-	-
	2	-	-	-	-	-	-	-	-	-	-	-	-
	3	-	-	-	-	-	-	-	-	-	-	-	-
S	1	-	-	-	-	-	-	50	40	30	40	35	30
	2	-	-	-	-	-	-	50	40	30	40	35	30
	3	-	-	-	-	-	-	60	50	30	55	40	30
	4	-	-	-	-	-	-	85	60	40	70	55	35
H	1	-	-	-	170	140	115	145	110	85	-	-	-
	2	-	-	-	-	-	-	-	-	-	-	-	-
	3	-	-	-	-	-	-	-	-	-	-	-	-

(continued)

(Recommended Starting Speeds [m/min] – continued)

Material Group		WP35CM			WS30PM			WP40PM		
P	1	545	475	445	–	–	–	355	310	295
	2	335	305	275	–	–	–	300	260	215
	3	305	275	245	–	–	–	275	235	190
	4	230	210	190	–	–	–	245	205	160
	5	310	275	250	–	–	–	205	185	160
	6	190	160	130	–	–	–	180	140	110
M	1	245	220	185	270	240	220	235	205	185
	2	220	190	170	245	215	175	210	180	150
	3	175	155	140	185	160	125	155	140	110
K	1	355	320	290	–	–	–	–	–	–
	2	280	250	230	–	–	–	–	–	–
	3	235	210	190	–	–	–	–	–	–
N	1	–	–	–	–	–	–	–	–	–
	2	–	–	–	–	–	–	–	–	–
	3	–	–	–	–	–	–	–	–	–
S	1	–	–	–	55	50	35	50	40	35
	2	–	–	–	55	50	35	50	40	35
	3	–	–	–	65	55	35	60	50	35
	4	80	60	40	100	70	50	80	60	40
H	1	–	–	–	–	–	–	–	–	–
	2	–	–	–	–	–	–	–	–	–
	3	–	–	–	–	–	–	–	–	–

NOTE: FIRST choice starting speeds are in **bold** type.
As the average chip thickness increases, the speed should be decreased.

Copy Mills

Recommended Starting Feeds

■ Recommended Starting Feeds [mm]

Light Machining	General Purpose	Heavy Machining
-----------------	-----------------	-----------------

For All Other Applications

Insert Geometry	Programmed Feed per Tooth (fz) as a % of Radial Depth of Cut (ae)															Insert Geometry
	5%			10%			20%			30%			40–100%			
..MM	0,90	1,87	3,62	0,65	1,33	2,52	0,48	0,99	1,86	0,42	0,86	1,61	0,39	0,79	1,47	..MM
..MH	0,90	2,35	4,97	0,65	1,67	3,40	0,48	1,23	2,48	0,42	1,07	2,15	0,39	0,98	1,96	..MH
..MR	0,90	2,81	5,44	0,65	1,97	3,69	0,48	1,46	2,69	0,42	1,27	2,33	0,39	1,16	2,13	..MR

NOTE: Use "Light Machining" value as starting feed rate.

Applying High-Feed Tools

The high-feed concept bases its strategy on small depth of cut and higher fz values, which results in a higher MRR and productivity with low radial forces.

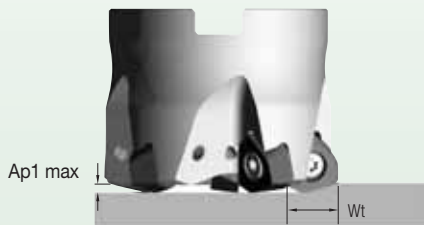

Small A_{p1} values and higher feed rates generate lower cutting forces versus traditional milling strategies.

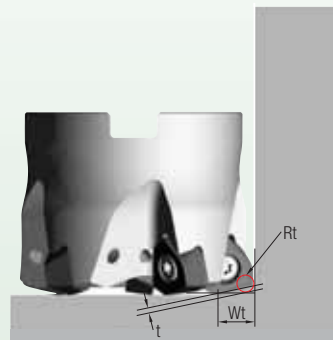

For CAM programming, the tools can be programmed as a toroidal tool type by using the R_t value as the insert radius.



Recommended when long overhang is necessary due to lower radial forces. Maximum L/D ratio of $10 \times D$.

General Programming Information for Applying M370

	CAM programming information		
	R_t	W_t	t
mm value	3,2	9	1,4

■ Maximum Linear Ramping and Helical Interpolation from Solid • Metric

diameter	max ramp angle	max ramp angle for 360° helical interpolation	max plunge depth	min hole diameter (DH min)	max flat-bottom hole diameter (DH1 max)	max diameter (no flat bottom)
42	5,1°	1,44°	1,66	57,36	65,29	84
50	3,7°	1,09°	1,66	73,07	81,24	100
52	3,5°	1,03°	1,66	77,03	85,24	104
63	2,6°	0,78°	1,66	98,88	107,20	126
66	2,4°	0,74°	1,66	104,85	113,20	132
80	1,8°	0,57°	1,66	132,77	141,18	160
100	1,3°	0,43°	1,66	172,70	181,16	200
125	1,0°	0,33°	1,66	222,66	231,15	250

On the Web

We are here to serve you.

Visit our homepage at widia.com to:

- Find a Local WIDIA™ Authorised Distributor near you.
- Contact our Customer Application Support team for technical support and product recommendations.
- Log in to NOVO™ for instant access to inventory availability, application recommendations, CAD drawings, and 3D models.
- Purchase WIDIA-branded merchandise.
- Get social with us on Facebook, Twitter, Instagram, YouTube, and more!

NOVO™

You can also use our NOVO app to guide you to the correct choice!

For more information, please visit widia.com/novo.

NOVO: The Digital Source for Delivering Smart Machining Solutions



For more information, contact your local WIDIA Authorised Distributor or visit widia.com/services.



WIDIA™

Double-Sided Round Insert •

M200™ Series

Revolutionary double-sided round insert, capable of running in multiple types of milling operations and workpiece materials, increases customer's productivity with the most efficient cost per edge.

M200



- Up to 12 cutting edges per insert.
- Effective anti-rotation feature.
- Able to apply in all type of materials and milling applications.
- Latest WIDIA™ Victory™ grades offered.

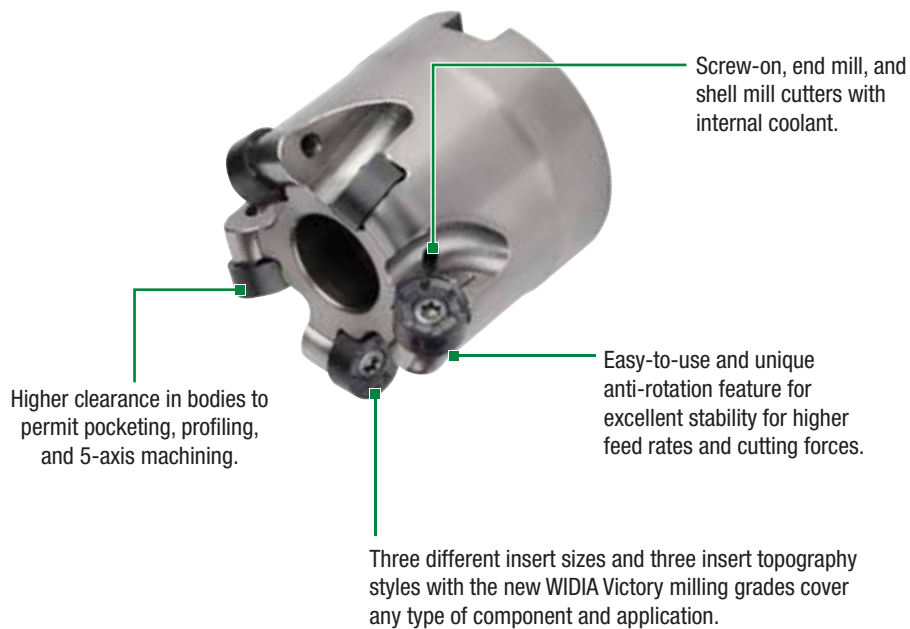

Copy Mills



M200™

Max depth of cut: up to 5mm

Indexes per insert: up to 12
Diameter: 25–125mm

Pages: J20–J39

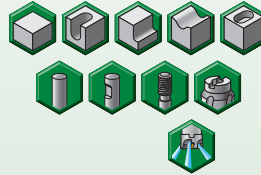
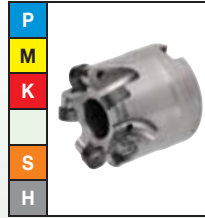

■ Insert Offering



M200 iC 10
10mm iC insert
8 cutting edges



M200 iC 12
12mm iC insert
12 cutting edges



M200 iC 16
16mm iC insert
12 cutting edges

- Double-sided, eight cutting edges.
- Anti-rotation feature for better stability and higher feed rates.
- Pocketing and profiling capabilities.

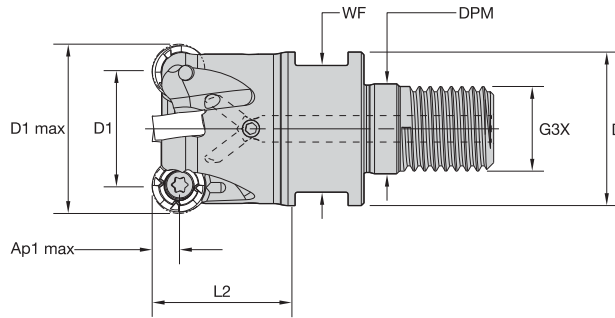
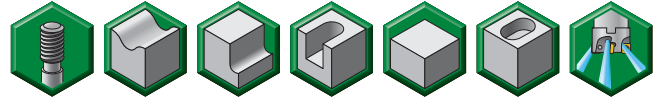

■ Screw-On End Mills

order number	catalogue number	D1 max	D1	D	DPM	G3X	L2	WF	Ap1 max	Z	max RPM	coolant supply	kg
5210273	M200D25Z03M12RN10	25	15	21	12,5	M12	32	17	5,0	3	54700	Yes	0,08
5210274	M200D32Z04M16RN10	32	22	29	17,0	M16	40	24	5,0	4	48300	Yes	0,18
5210275	M200D35Z05M16RN10	35	24	29	17,0	M16	40	24	5,0	5	46200	Yes	0,20
5210276	M200D42Z06M16RN10	42	32	29	17,0	M16	40	24	5,0	6	42200	Yes	0,24

■ Spare Parts



insert screw

191.848



Nm

2,0



Torx driver

170.025

- Double-sided, eight cutting edges.
- Anti-rotation feature for better stability and higher feed rates.
- Pocketing and profiling capabilities.

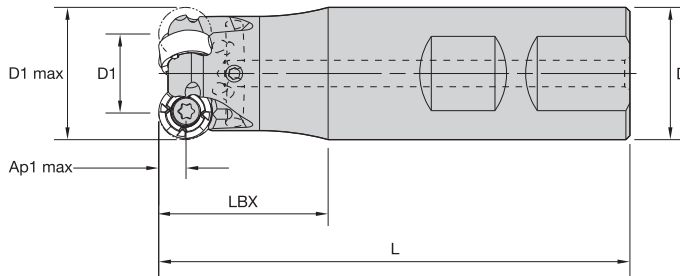

■ **Weldon Shanks**

order number	catalogue number	D1 max	D1	D	L	LBX	Ap1 max	Z	max RPM	coolant supply	kg
5210277	M200D25Z03B25RN10	25	15	25	89	40	5,0	3	54700	Yes	0,27
5210278	M200D32Z04B32RN10	32	22	32	101	40	5,0	4	48300	Yes	0,52

■ **Spare Parts**



insert screw

191.848



Nm

2,0



Torx driver

170.025

Copy Mills

- Double-sided, eight cutting edges.
- Anti-rotation feature for better stability and higher feed rates.
- Pocketing and profiling capabilities.

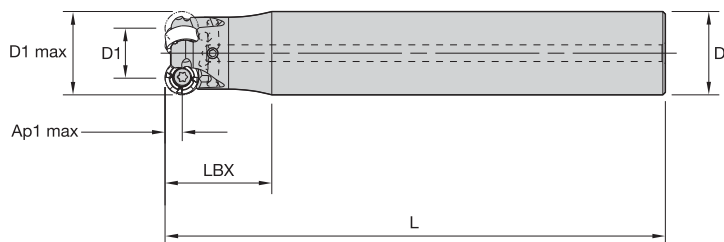
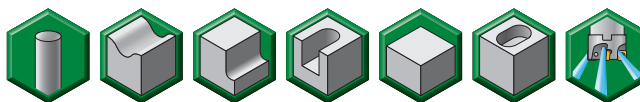

■ Cylindrical End Mills

order number	catalogue number	D1 max	D1	D	L	LBX	L2	Ap1 max	Z	max RPM	coolant supply	kg
5210279	M200D25Z03A25RN10L150	25	15	25	150	32	32	5,0	3	54700	Yes	0,50
5210300	M200D25Z03A25RN10L200	25	15	25	200	32	32	5,0	3	54700	Yes	0,69
5210301	M200D25Z03A32RN10L250	25	15	32	250	32	32	5,0	3	54700	Yes	1,42
5210302	M200D28Z03A25RN10L200	28	18	25	200	40	40	5,0	3	51600	Yes	0,70
5210303	M200D32Z04A32RN10L150	32	22	32	150	40	40	5,0	4	48300	Yes	0,83
5210304	M200D32Z03A32RN10L200	32	22	32	200	40	40	5,0	3	48300	Yes	1,14

■ Spare Parts



insert screw

191.848



Nm

2,0



Torx driver

170.025

- Double-sided, eight cutting edges.
- Anti-rotation feature for better stability and higher feed rates.
- Pocketing and profiling capabilities.

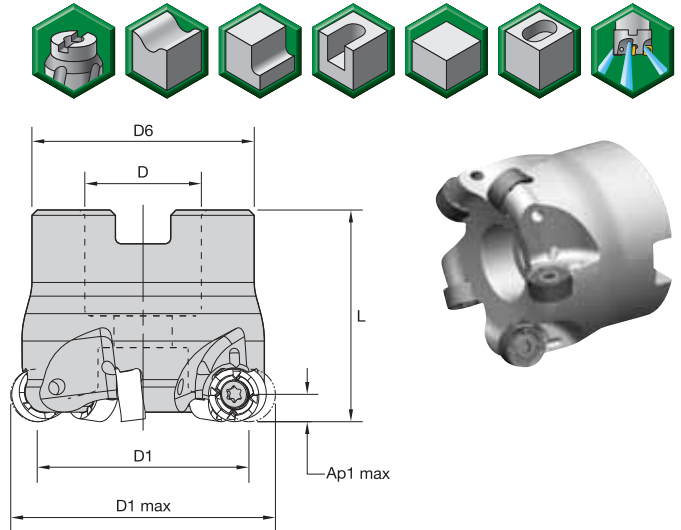

■ **Shell Mills**

order number	catalogue number	D1 max	D1	D	D6	L	Ap1 max	Z	max RPM	coolant supply	kg
5210305	M200D40Z04RN10	40	30	16	38	40	5,0	4	43200	Yes	0,23
5210306	M200D40Z06RN10	40	30	16	38	40	5,0	6	43200	Yes	0,24
5210307	M200D50Z05RN10	50	40	22	42	40	5,0	5	38600	Yes	0,32
5210308	M200D50Z06RN10	50	40	22	42	40	5,0	6	38600	Yes	0,32
5210309	M200D52Z06RN10	52	42	22	49	50	5,0	6	37900	Yes	0,52

■ **Spare Parts**

D1 max	insert screw	Nm	wrench	socket-head cap screw	socket-head cap screw with coolant groove
40	191.848	2,0	170.025	MS1294	MS1294CG
50	191.848	2,0	170.025	MS1234	MS1234CG
52	191.848	2,0	170.025	MS1242	MS1242CG

NOTE: Socket-head cap screw and socket-head cap screw with coolant groove must be ordered separately.

Copy Mills

■ Insert Selection Guide

Material Group	Light Machining		General Purpose		Heavy Machining	
	Geometry	Grade	Geometry	Grade	Geometry	Grade
P1-P2	ML	WP25PM	MM	WP40PM	MM	WP40PM
P3-P4	ML	WP25PM	MM	WP25PM	MH	WP40PM
P5-P6	ML	WP35CM	MM	WP35CM	MH	WP35CM
M1-M2	ML	WP25PM	ML	WU35PM	MM	WU35PM
M3	ML	WP25PM	MM	WU35PM	MM	WU35PM
K1-K2	MH	WK15CM	MH	WK15CM	MH	WP20CM
K3	MH	WK15CM	MH	WK15CM	MH	WP25PM
N1-N2	-	-	-	-	-	-
N3	-	-	-	-	-	-
S1-S2	ML	WS30PM	MM	WS30PM	MM	WU35PM
S3	ML	WS30PM	MM	WU35PM	MM	WU35PM
S4	ML	WS30PM	MM	WU35PM	MM	WU35PM
H1	MH	WP25PM	MH	WP20CM	-	-

Copy Mills

iC10 • Inserts • RN.J10...

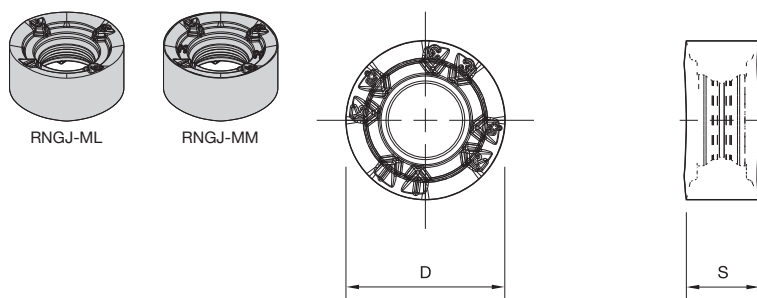

- ML geometry is the first choice for stainless steel and high-temp alloys.
- MM geometry is for general purpose, especially for steel.

● first choice
○ alternate choice

P	●	●	●	●	●	●	●
M	○	○	○	○	○	○	○
K	○	○	○	○	○	○	○
N	○	○	○	○	○	○	○
S	○	○	○	○	○	○	○
H	○	○	○	○	○	○	○

■ RINGJ-ML

catalogue number	number of indexes	D	S	WK15CM	WP20CM	WP25PM	WS30PM	WU35PM	WP35CM	WP40PM
RNGJ10T3M0EML	8	10,00	4,76	○	○	●	●	●	○	○

■ RINGJ-MM

catalogue number	number of indexes	D	S	WK15CM	WP20CM	WP25PM	WS30PM	WU35PM	WP35CM	WP40PM
RNGJ10T3M0SMM	8	10,00	4,76	○	○	○	○	○	○	○

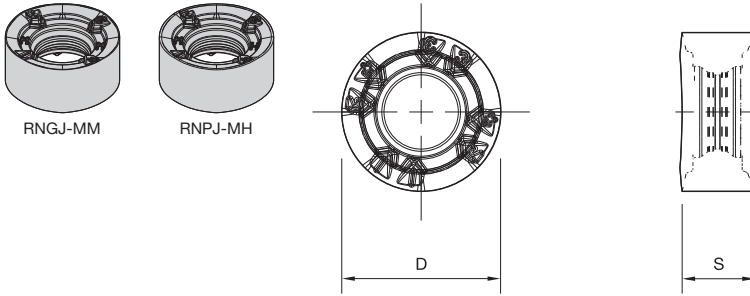

- -MM geometry is for general purpose, especially for steel.
- -MH geometry is the first choice for heavy applications, cast iron, and high-strength steel.

● first choice
○ alternate choice

P	●	●	●	●	●	●	●
M	○	○	○	○	○	○	○
K	●	○	○	○	○	○	○
N	○	○	○	○	○	○	○
S	○	○	○	○	○	○	○
H	○	○	○	○	○	○	○

■ RNPJ-MM

catalogue number	number of indexes	D	S	WK15CM	WP20CM	WP25PM	WS30PM	WU35PM	WP35CM	WP40PM
RNPJ10T3M0SMM	8	10,00	4,76	○	○	○	○	○	○	○

■ RNPJ-MH

catalogue number	number of indexes	D	S	WK15CM	WP20CM	WP25PM	WS30PM	WU35PM	WP35CM	WP40PM
RNPJ10T3M0SMH	8	10,00	4,76	○	○	○	○	○	○	○

Copy Mills

■ Recommended Starting Speeds [m/min]

Material Group		WK15CM			WP20CM			WP25PM			WS30PM		
P	1	-	-	-	660	580	540	395	340	325	-	-	-
	2	-	-	-	410	370	330	330	290	240	-	-	-
	3	-	-	-	370	330	305	305	260	210	-	-	-
	4	-	-	-	275	260	230	270	220	180	-	-	-
	5	-	-	-	330	300	275	220	205	180	-	-	-
	6	-	-	-	230	205	175	200	150	120	-	-	-
M	1	-	-	-	270	240	210	245	215	200	270	240	220
	2	-	-	-	245	210	190	220	190	155	245	215	175
	3	-	-	-	190	175	150	170	145	115	185	160	125
K	1	505	460	410	430	390	355	275	245	220	-	-	-
	2	400	355	330	340	305	280	215	190	180	-	-	-
	3	335	300	275	290	260	240	180	160	145	-	-	-
N	1	-	-	-	-	-	-	-	-	-	-	-	-
	2	-	-	-	-	-	-	-	-	-	-	-	-
	3	-	-	-	-	-	-	-	-	-	-	-	-
S	1	-	-	-	-	-	-	50	40	30	55	50	35
	2	-	-	-	-	-	-	50	40	30	55	50	35
	3	-	-	-	-	-	-	60	50	30	65	55	35
	4	-	-	-	-	-	-	85	60	40	100	70	50
H	1	-	-	-	170	140	115	145	110	85	-	-	-
	2	-	-	-	-	-	-	-	-	-	-	-	-
	3	-	-	-	-	-	-	-	-	-	-	-	-

Copy Mills

Material Group		WU35PM			WP35CM			WP40PM		
P	1	310	275	260	545	475	445	355	310	295
	2	265	230	190	335	305	275	300	260	215
	3	240	205	170	305	275	245	275	235	190
	4	215	180	145	230	210	190	245	205	160
	5	180	160	145	310	275	250	205	185	160
	6	155	120	95	190	160	130	180	140	110
M	1	205	180	160	245	220	185	235	205	185
	2	185	155	130	220	190	170	210	180	150
	3	140	120	95	175	155	140	155	140	110
K	1	-	-	-	355	320	290	-	-	-
	2	-	-	-	280	250	230	-	-	-
	3	-	-	-	235	210	190	-	-	-
N	1	-	-	-	-	-	-	-	-	-
	2	-	-	-	-	-	-	-	-	-
	3	-	-	-	-	-	-	-	-	-
S	1	40	35	30	-	-	-	50	40	35
	2	40	35	30	-	-	-	50	40	35
	3	55	40	30	-	-	-	60	50	35
	4	70	55	35	80	60	40	80	60	40
H	1	-	-	-	-	-	-	-	-	-
	2	-	-	-	-	-	-	-	-	-
	3	-	-	-	-	-	-	-	-	-

NOTE: FIRST choice starting speeds are in **bold** type.
As the average chip thickness increases, the speed should be decreased.

■ Recommended Starting Feeds [mm]

Light Machining	General Purpose	Heavy Machining
-----------------	-----------------	-----------------

At 5,00 Axial Depth of Cut (ap)

Insert Geometry	Programmed Feed per Tooth (fz) as a % of Radial Depth of Cut (ae)															Insert Geometry
	5%			10%			20%			30%			40-100%			
ML	0,13	0,44	0,80	0,10	0,32	0,57	0,07	0,24	0,43	0,06	0,21	0,37	0,06	0,19	0,34	ML
MM	0,28	0,50	0,91	0,20	0,36	0,66	0,15	0,27	0,49	0,13	0,24	0,43	0,12	0,22	0,39	MM
MH	0,46	0,58	0,96	0,33	0,42	0,69	0,25	0,31	0,51	0,22	0,27	0,45	0,20	0,25	0,41	MH

At 2,50 Axial Depth of Cut (ap)

Insert Geometry	Programmed Feed per Tooth (fz) as a % of Radial Depth of Cut (ae)															Insert Geometry
	5%			10%			20%			30%			40-100%			
ML	0,15	0,51	0,92	0,11	0,37	0,66	0,08	0,27	0,49	0,07	0,24	0,43	0,07	0,22	0,39	ML
MM	0,32	0,58	1,06	0,23	0,42	0,76	0,18	0,31	0,57	0,15	0,27	0,49	0,14	0,25	0,45	MM
MH	0,54	0,67	1,11	0,39	0,48	0,80	0,29	0,36	0,59	0,25	0,32	0,52	0,23	0,29	0,47	MH

At 1,25 Axial Depth of Cut (ap)

Insert Geometry	Programmed Feed per Tooth (fz) as a % of Radial Depth of Cut (ae)															Insert Geometry
	5%			10%			20%			30%			40-100%			
ML	0,20	0,67	1,21	0,14	0,48	0,87	0,11	0,36	0,65	0,09	0,31	0,56	0,09	0,29	0,52	ML
MM	0,43	0,77	1,39	0,31	0,55	1,00	0,23	0,41	0,74	0,20	0,36	0,65	0,18	0,33	0,59	MM
MH	0,70	0,88	1,46	0,51	0,63	1,04	0,38	0,47	0,78	0,33	0,41	0,68	0,30	0,38	0,62	MH

At 0,63 Axial Depth of Cut (ap)

Insert Geometry	Programmed Feed per Tooth (fz) as a % of Radial Depth of Cut (ae)															Insert Geometry
	5%			10%			20%			30%			40-100%			
ML	0,27	0,92	1,67	0,20	0,66	1,19	0,15	0,49	0,89	0,13	0,43	0,77	0,12	0,39	0,71	ML
MM	0,58	1,05	1,92	0,42	0,75	1,37	0,31	0,56	1,02	0,27	0,49	0,88	0,25	0,45	0,81	MM
MH	0,96	1,21	2,02	0,69	0,87	1,43	0,52	0,65	1,06	0,45	0,56	0,93	0,41	0,52	0,85	MH

NOTE: Use "Light Machining" value as starting feed rate.

Copy Mills

- Double-sided, 12 cutting edges.
- Anti-rotation feature for better stability and higher feed rates.
- Pocketing and profiling capabilities.

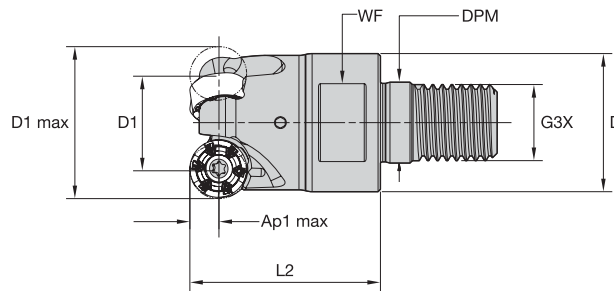
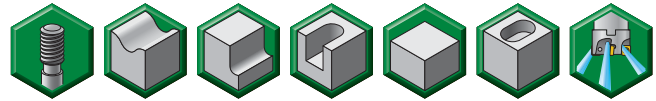

■ Screw-On End Mills

order number	catalogue number	D1 max	D1	D	DPM	G3X	L2	WF	Ap1 max	Z	max RPM	coolant supply	kg
4147560	M200D32Z03M16RN12	32	20	29	17,0	M16	40	24	3,0	3	39160	Yes	0,18
4147561	M200D35Z03M16RN12	35	23	29	17,0	M16	40	24	3,0	3	37440	Yes	0,19
4147562	M200D42Z04M16RN12	42	30	29	17,0	M16	40	24	3,0	4	34180	Yes	0,24

■ Spare Parts



D1 max	insert screw	Nm	Torx driver
32	193.492	4,0	170.025
35	193.492	4,0	170.025
42	193.492	4,0	170.025

Copy Mills

- Double-sided, 12 cutting edges.
- Anti-rotation feature for better stability and higher feed rates.
- Pocketing and profiling capabilities.

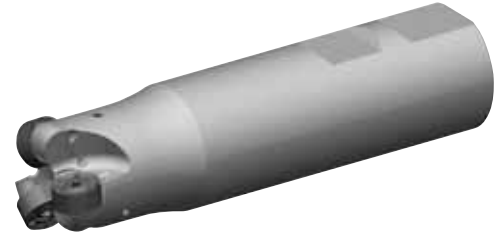
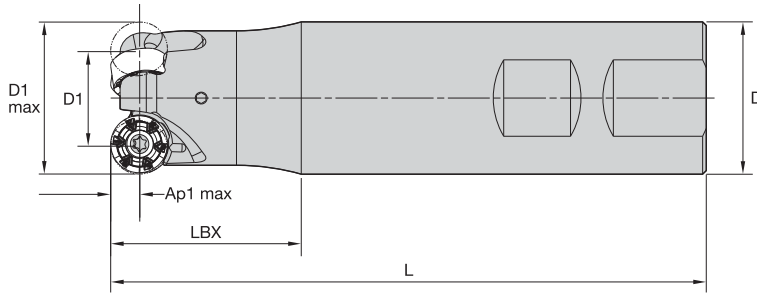

■ **Weldon Shanks**

order number	catalogue number	D1 max	D1	D	L	LBX	Ap1 max	Z	max RPM	coolant supply	kg
4147564	M200D32Z03B32RN12	32	20	32	125	40	3,0	3	39160	Yes	0,65

■ **Spare Parts**

			
D1 max	insert screw	Nm	Torx driver
32	193.492	4,0	170.025

Copy Mills

- Double-sided, 12 cutting edges.
- Anti-rotation feature for better stability and higher feed rates.
- Pocketing and profiling capabilities.

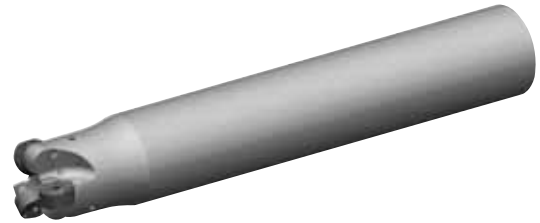
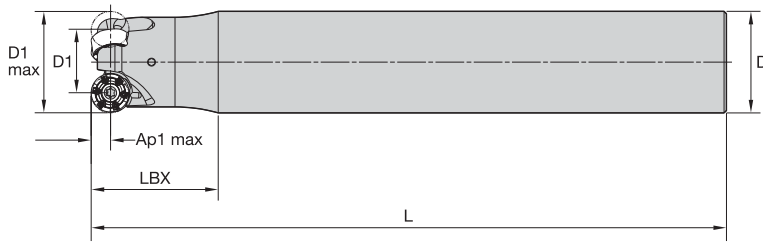
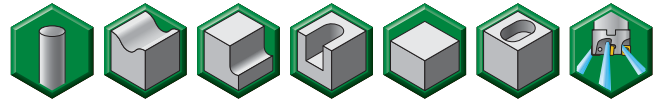

■ Cylindrical End Mills

order number	catalogue number	D1 max	D1	D	L	LBX	Ap1 max	Z	max RPM	coolant supply	kg
4147566	M200D32Z03A32RN12L200	32	20	32	200	40	3,0	3	39160	Yes	1,10
4147567	M200D32Z02A32RN12L250	32	20	32	250	40	3,0	2	39160	Yes	1,41

■ Spare Parts

D1 max	insert screw	Nm	Torx driver
32	193.492	4,0	170.025

Copy Mills

- Double-sided, 12 cutting edges.
- Anti-rotation feature for better stability and higher feed rates.
- Pocketing and profiling capabilities.

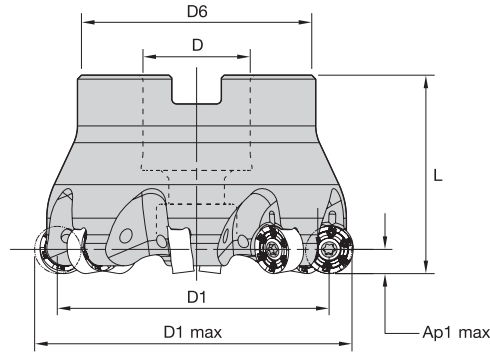

■ **Shell Mills**

order number	catalogue number	D1 max	D1	D	D6	L	Ap1 max	Z	max RPM	coolant supply	kg
4147568	M200D40Z04RN12	40	28	16	38	40	3,0	4	35020	Yes	0,22
4147569	M200D50Z04RN12	50	38	22	42	40	3,0	4	31330	Yes	0,30
4147570	M200D50Z05RN12	50	38	22	42	40	3,0	5	31330	Yes	0,29
4147571	M200D52Z05RN12	52	40	22	49	50	3,0	5	30720	Yes	0,49
4147572	M200D63Z05RN12	63	51	22	49	50	3,0	5	27910	Yes	0,63
4147573	M200D63Z07RN12	63	51	22	49	50	3,0	7	27910	Yes	0,63
4147574	M200D66Z07RN12	66	54	27	60	50	3,0	7	27260	Yes	0,82
4147575	M200D80Z06RN12	80	68	27	60	50	3,0	6	24760	Yes	1,02
4147576	M200D80Z08RN12	80	68	27	60	50	3,0	8	24760	Yes	1,02
4147577	M200D100Z07RN12	100	88	32	78	50	3,0	7	22150	Yes	1,45
4147578	M200D100Z09RN12	100	88	32	78	50	3,0	9	22150	Yes	1,41

■ **Spare Parts**



D1 max	insert screw	Nm	wrench	low-head cap screw	socket-head cap screw	socket-head cap screw with coolant groove	coolant lock screw	coolant lock screw assembly
40	193.492	4,0	170.025	—	MS1294	MS1294CG	—	—
50	193.492	4,0	170.025	MS1336	—	MS2072CG	—	—
52	193.492	4,0	170.025	—	MS1242	MS1242CG	—	—
63	193.492	4,0	170.025	—	MS1242	MS1242CG	—	—
66	193.492	4,0	170.025	—	MS2038	MS2038CG	—	—
80	193.492	4,0	170.025	—	MS2038	MS2038CG	—	—
100	193.492	4,0	170.025	—	—	—	KLS32M	MS2195C

NOTE: Socket-head cap screw with coolant groove and coolant lock screw assembly must be ordered separately.

■ Insert Selection Guide

Material Group	Light Machining		General Purpose		Heavy Machining	
	Geometry	Grade	Geometry	Grade	Geometry	Grade
P1-P2	ML	WP25PM	MM	WP40PM	MM	WP40PM
P3-P4	ML	WP25PM	MM	WP25PM	MH	WP40PM
P5-P6	ML	WP35CM	MM	WP35CM	MH	WP35CM
M1-M2	ML	WP25PM	ML	WU35PM	MM	WU35PM
M3	ML	WP25PM	MM	WU35PM	MM	WU35PM
K1-K2	MH	WK15CM	MH	WK15CM	MH	WP20CM
K3	MH	WK15PM	MH	WK15PM	MH	WP25PM
N1-N2	-	-	-	-	-	-
N3	-	-	-	-	-	-
S1-S2	ML	WS30PM	MM	WS30PM	MM	WU35PM
S3	ML	WS30PM	MM	WU35PM	MM	WU35PM
S4	ML	WS30PM	MM	WU35PM	MM	WU35PM
H1	MH	WP25PM	MH	WP20CM	-	-

Copy Mills

iC12 • Inserts • RN.J12..

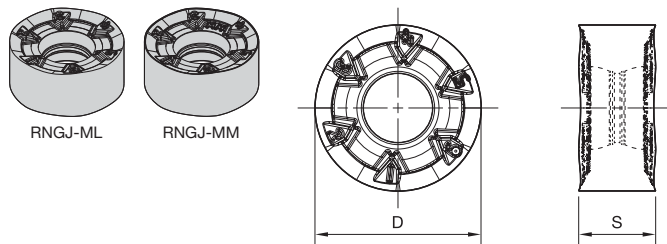

- -ML geometry is the first choice for stainless steel and high-temp alloys.
- -MM geometry is for general purpose, especially for steel.

- first choice
- alternate choice

P	●	●	●	●	●	●	●	●	●
M	○	○	○	○	○	○	○	○	○
K	●	○	○	○	○	○	○	○	○
N	○	○	○	○	○	○	○	○	○
S	○	○	○	○	○	○	○	○	○
H	○	○	○	○	○	○	○	○	○

■ RINGJ-ML

catalogue number	cutting edges	D	S	WK15PM	WK15CM	WP20CM	WP25PM	WS30PM	WU35PM	WP35CM	WP40PM
RNGJ1204M0EML	12	12,00	4,75	●	○	○	○	○	○	○	○

■ RINGJ-MM

catalogue number	cutting edges	D	S	WK15PM	WK15CM	WP20CM	WP25PM	WS30PM	WU35PM	WP35CM	WP40PM
RNGJ1204M0SMM	12	12,00	4,75	○	○	○	○	○	○	○	○

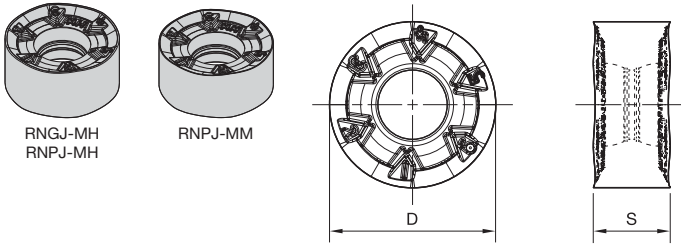

- -MM geometry is for general purpose, especially for steel.
- -MH geometry is the first choice for heavy applications, cast iron, and high-strength steel.

- first choice
- alternate choice

P	●	○	○	○	○	○	○	○	○
M	○	○	○	○	○	○	○	○	○
K	○	○	○	○	○	○	○	○	○
N	○	○	○	○	○	○	○	○	○
S	○	○	○	○	○	○	○	○	○
H	○	○	○	○	○	○	○	○	○

■ RINGJ-MH

catalogue number	cutting edges	D	S	WK15PM	WK15CM	WP20CM	WP25PM	WS30PM	WU35PM	WP35CM	WP40PM
RNGJ1204M0SMH	12	12,00	4,75	●	○	○	○	○	○	○	○
				5123900	-	-	5123901	-	5123902	5123903	-

■ RNPJ-MM

catalogue number	cutting edges	D	S	WK15PM	WK15CM	WP20CM	WP25PM	WS30PM	WU35PM	WP35CM	WP40PM
RNPJ1204M0SMM	12	12,00	4,75	○	○	○	○	○	○	○	○
				-	-	5276362	5276361	-	5476634	5276360	5542329

■ RNPJ-MH

catalogue number	cutting edges	D	S	WK15PM	WK15CM	WP20CM	WP25PM	WS30PM	WU35PM	WP35CM	WP40PM
RNPJ1204M0SMH	12	12,00	4,75	○	○	○	○	○	○	○	○
				-	5276366	5276365	5276364	-	5476635	5276363	5542340



■ Recommended Starting Speeds [m/min]

Material Group		WK15PM			WK15CM			WP20CM			WP25PM		
P	1	-	-	-	-	-	-	660	580	540	395	340	325
	2	-	-	-	-	-	-	410	370	330	330	290	240
	3	-	-	-	-	-	-	370	330	305	305	260	210
	4	-	-	-	-	-	-	275	260	230	270	220	180
	5	-	-	-	-	-	-	330	300	275	220	205	180
	6	-	-	-	-	-	-	230	205	175	200	150	120
M	1	-	-	-	-	-	-	270	240	210	245	215	200
	2	-	-	-	-	-	-	245	210	190	220	190	155
	3	-	-	-	-	-	-	190	175	150	170	145	115
K	1	325	295	260	505	460	410	430	390	355	275	245	220
	2	250	230	210	400	355	330	340	305	280	215	190	180
	3	210	190	175	335	300	275	290	260	240	180	160	145
N	1	-	-	-	-	-	-	-	-	-	-	-	-
	2	-	-	-	-	-	-	-	-	-	-	-	-
	3	-	-	-	-	-	-	-	-	-	-	-	-
S	1	-	-	-	-	-	-	-	-	-	50	40	30
	2	-	-	-	-	-	-	-	-	-	50	40	30
	3	-	-	-	-	-	-	-	-	-	60	50	30
	4	-	-	-	-	-	-	-	-	-	85	60	40
H	1	-	-	-	-	-	-	170	140	115	145	110	85
	2	-	-	-	-	-	-	-	-	-	-	-	-
	3	-	-	-	-	-	-	-	-	-	-	-	-

Copy Mills

Material Group		WS30PM			WU35PM			WP35CM			WP40PM		
P	1	-	-	-	310	275	260	545	475	445	355	310	295
	2	-	-	-	265	230	190	335	305	275	300	260	215
	3	-	-	-	240	205	170	305	275	245	275	235	190
	4	-	-	-	215	180	145	230	210	190	245	205	160
	5	-	-	-	180	160	145	310	275	250	205	185	160
	6	-	-	-	155	120	95	190	160	130	180	140	110
M	1	270	240	220	205	180	160	245	220	185	235	205	185
	2	245	215	175	185	155	130	220	190	170	210	180	150
	3	185	160	125	140	120	95	175	155	140	155	140	110
K	1	-	-	-	-	-	-	355	320	290	-	-	-
	2	-	-	-	-	-	-	280	250	230	-	-	-
	3	-	-	-	-	-	-	235	210	190	-	-	-
N	1	-	-	-	-	-	-	-	-	-	-	-	-
	2	-	-	-	-	-	-	-	-	-	-	-	-
	3	-	-	-	-	-	-	-	-	-	-	-	-
S	1	55	50	35	40	35	30	-	-	-	50	40	35
	2	55	50	35	40	35	30	-	-	-	50	40	35
	3	65	55	35	55	40	30	-	-	-	60	50	35
	4	100	70	50	70	55	35	80	60	40	80	60	40
H	1	-	-	-	-	-	-	-	-	-	-	-	-
	2	-	-	-	-	-	-	-	-	-	-	-	-
	3	-	-	-	-	-	-	-	-	-	-	-	-

NOTE: FIRST choice starting speeds are in **bold** type.
As the average chip thickness increases, the speed should be decreased.

■ Recommended Starting Feeds [mm]

Light Machining	General Purpose	Heavy Machining
-----------------	-----------------	-----------------

At 6,00 Axial Depth of Cut (ap)

Insert Geometry	Programmed Feed per Tooth (fz) as a % of Radial Depth of Cut (ae)															Insert Geometry
	5%			10%			20%			30%			40-100%			
ML	0,12	0,18	0,32	0,09	0,13	0,23	0,07	0,10	0,18	0,06	0,08	0,15	0,05	0,08	0,14	ML
MM	0,28	0,51	0,84	0,21	0,37	0,61	0,15	0,28	0,45	0,13	0,24	0,39	0,12	0,22	0,36	MM
MH	0,46	0,70	1,02	0,33	0,50	0,73	0,25	0,38	0,55	0,22	0,33	0,48	0,20	0,30	0,44	MH

At 3,00 Axial Depth of Cut (ap)

Insert Geometry	Programmed Feed per Tooth (fz) as a % of Radial Depth of Cut (ae)															Insert Geometry
	5%			10%			20%			30%			40-100%			
ML	0,14	0,20	0,37	0,10	0,15	0,27	0,08	0,11	0,20	0,07	0,10	0,18	0,06	0,09	0,16	ML
MM	0,33	0,59	0,97	0,24	0,43	0,70	0,18	0,32	0,52	0,16	0,28	0,45	0,14	0,25	0,42	MM
MH	0,54	0,81	1,18	0,39	0,58	0,85	0,29	0,43	0,63	0,25	0,38	0,55	0,23	0,35	0,51	MH

At 1,50 Axial Depth of Cut (ap)

Insert Geometry	Programmed Feed per Tooth (fz) as a % of Radial Depth of Cut (ae)															Insert Geometry
	5%			10%			20%			30%			40-100%			
ML	0,18	0,27	0,49	0,13	0,19	0,35	0,10	0,15	0,26	0,09	0,13	0,23	0,08	0,12	0,21	ML
MM	0,43	0,77	1,28	0,31	0,56	0,92	0,23	0,42	0,68	0,20	0,36	0,60	0,19	0,33	0,55	MM
MH	0,70	1,06	1,56	0,51	0,76	1,12	0,38	0,57	0,83	0,33	0,50	0,72	0,30	0,45	0,66	MH

At 0,75 Axial Depth of Cut (ap)

Insert Geometry	Programmed Feed per Tooth (fz) as a % of Radial Depth of Cut (ae)															Insert Geometry
	5%			10%			20%			30%			40-100%			
ML	0,25	0,37	0,67	0,18	0,27	0,48	0,14	0,20	0,36	0,12	0,17	0,32	0,11	0,16	0,29	ML
MM	0,59	1,06	1,77	0,43	0,76	1,26	0,32	0,57	0,94	0,28	0,50	0,81	0,25	0,45	0,75	MM
MH	0,96	1,46	2,16	0,69	1,04	1,53	0,52	0,78	1,14	0,45	0,68	0,99	0,41	0,62	0,90	MH

NOTE: Use "Light Machining" value as starting feed rate.

Copy Mills

- Double-sided, 12 cutting edges.
- Anti-rotation feature for better stability and higher feed rates.
- Pocketing and profiling capabilities.

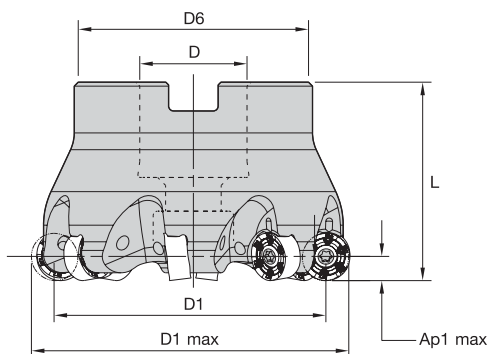

■ Shell Mills

order number	catalogue number	D1 max	D1	D	D6	L	Ap1 max	Z	max RPM	coolant supply	kg
5209989	M200D50Z04RN16	50	34	22	42	50	4,0	4	26700	Yes	0,36
5210210	M200D52Z04RN16	52	36	22	42	50	4,0	4	26000	Yes	0,39
5210212	M200D63Z06RN16	63	47	22	49	50	4,0	6	22700	Yes	0,56
5210211	M200D63Z04RN16	63	47	22	49	50	4,0	4	22700	Yes	0,58
5210213	M200D66Z05RN16	66	50	27	60	50	4,0	5	22000	Yes	0,69
5210214	M200D80Z05RN16	80	64	27	60	50	4,0	5	19500	Yes	0,88
5210215	M200D80Z07RN16	80	64	27	60	50	4,0	7	19500	Yes	0,89
5210216	M200D100Z06RN16	100	84	32	78	50	4,0	6	17000	Yes	1,36
5210217	M200D100Z08RN16	100	84	32	78	50	4,0	8	17000	Yes	1,37
5210218	M200D125Z08RN16	125	109	40	90	63	4,0	8	14900	Yes	2,50

■ Spare Parts

D1 max	insert screw	Nm	wrench	socket-head cap screw	socket-head cap screw with coolant groove	coolant lock screw	coolant lock screw assembly
50	192.932	4,0	170.026	MS1242	MS1242CG	—	—
52	MS2260	4,0	170.026	MS1242	MS1242CG	—	—
63	MS2260	4,0	170.026	MS1242	MS1242CG	—	—
63	193.343	4,0	170.026	MS1242	MS1242CG	—	—
66	MS2260	4,0	170.026	MS2038	MS2038CG	—	—
80	MS2260	4,0	170.026	MS2038	MS2038CG	—	—
100	MS2260	4,0	170.026	—	—	KLS32M	MS2195C
125	MS2260	4,0	170.026	—	—	KLS40M	MS2187C

NOTE: Socket-head cap screw with coolant groove and coolant lock screw assembly must be ordered separately.

■ **Insert Selection Guide**

Material Group	Light Machining		General Purpose		Heavy Machining	
	Geometry	Grade	Geometry	Grade	Geometry	Grade
P1-P2	ML	WP25PM	MM	WP40PM	MM	WP40PM
P3-P4	ML	WP25PM	MM	WP25PM	MH	WP40PM
P5-P6	ML	WP35CM	MM	WP35CM	MH	WP35CM
M1-M2	ML	WP25PM	ML	WU35PM	MM	WU35PM
M3	ML	WP25PM	MM	WU35PM	MM	WU35PM
K1-K2	MH	WK15CM	MH	WK15CM	MH	WP20CM
K3	MH	WK15CM	MH	WP20CM	MH	WP35CM
N1-N2	-	-	-	-	-	-
N3	-	-	-	-	-	-
S1-S2	ML	WS30PM	ML	WS30PM	ML	WU35PM
S3	ML	WS30PM	ML	WU35PM	ML	WU35PM
S4	ML	WS30PM	ML	WU35PM	ML	WU35PM
H1	MH	WP25PM	MH	WP20CM	-	-

iC16 • Inserts • RN.J16...

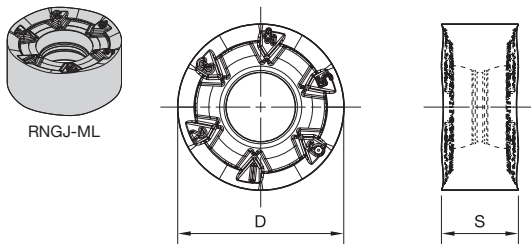

- -ML geometry is the first choice for stainless steel and high-temp alloys.

- first choice
- alternate choice

P	●	●	●	●	●	●	●
M	○	○	○	○	○	○	○
K	●	○	○	○	○	○	○
N	○	○	○	○	○	○	○
S	○	○	○	○	○	○	○
H	○	○	○	○	○	○	○

■ **RNGJ-ML**

catalogue number	cutting edges	D	S	WK15CM	WP20CM	WP25PM	WS30PM	WU35PM	WP35CM	WP40PM
RNGJ1605M0EML	12	16,00	6,35	-	-	5274561	5520354	5274562	5274560	-

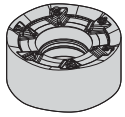

RNPJ-MM
RNPJ-MH

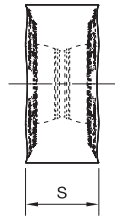
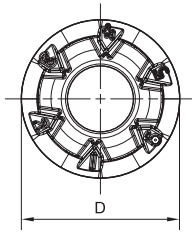

- -MM geometry is for general purpose, especially for steel.
- -MH geometry is the first choice for heavy applications, cast iron, and high-strength steels.

● first choice
○ alternate choice

P	●	●	●	●	●	●
M	○	○	○	○	○	○
K	○	○	○	○	○	○
N	○	○	○	○	○	○
S	○	○	○	○	○	○
H	○	○	○	○	○	○

■ RNPJ-MM

catalogue number	cutting edges	D	S	WK15CM	WP20CM	WP25PM	WS30PM	WU35PM	WP35CM	WP40PM
RNPJ1605M0SMM	12	16,00	6,35	○	5276472	5276471	○	5476637	5276470	5542341

■ RNPJ-MH

catalogue number	cutting edges	D	S	WK15CM	WP20CM	WP25PM	WS30PM	WU35PM	WP35CM	WP40PM
RNPJ1605M0SMH	12	16,00	6,35	5276476	5276475	5276474	○	5476636	5276473	5542342

Recommended Starting Speeds

■ Recommended Starting Speeds [m/min]

Material Group		WK15CM			WP20CM			WP25PM			WS30PM		
P	1	-	-	-	660	580	540	395	340	325	-	-	-
	2	-	-	-	410	370	330	330	290	240	-	-	-
	3	-	-	-	370	330	305	305	260	210	-	-	-
	4	-	-	-	275	260	230	270	220	180	-	-	-
	5	-	-	-	330	300	275	220	205	180	-	-	-
	6	-	-	-	230	205	175	200	150	120	-	-	-
M	1	-	-	-	270	240	210	245	215	200	270	240	220
	2	-	-	-	245	210	190	220	190	155	245	215	175
	3	-	-	-	190	175	150	170	145	115	185	160	125
K	1	505	460	410	430	390	355	275	245	220	-	-	-
	2	400	355	330	340	305	280	215	190	180	-	-	-
	3	335	300	275	290	260	240	180	160	145	-	-	-
N	1	-	-	-	-	-	-	-	-	-	-	-	-
	2	-	-	-	-	-	-	-	-	-	-	-	-
	3	-	-	-	-	-	-	-	-	-	-	-	-
S	1	-	-	-	-	-	-	50	40	30	55	50	35
	2	-	-	-	-	-	-	50	40	30	55	50	35
	3	-	-	-	-	-	-	60	50	30	65	55	35
	4	-	-	-	-	-	-	85	60	40	100	70	50
H	1	-	-	-	170	140	115	145	110	85	-	-	-
	2	-	-	-	-	-	-	-	-	-	-	-	-
	3	-	-	-	-	-	-	-	-	-	-	-	-

(Recommended Starting Speeds [m/min] – continued)

Material Group		WU35PM			WP35CM			WP40PM		
P	1	310	275	260	545	475	445	355	310	295
	2	265	230	190	335	305	275	300	260	215
	3	240	205	170	305	275	245	275	235	190
	4	215	180	145	230	210	190	245	205	160
	5	180	160	145	310	275	250	205	185	160
	6	155	120	95	190	160	130	180	140	110
M	1	205	180	160	245	220	185	235	205	185
	2	185	155	130	220	190	170	210	180	150
	3	140	120	95	175	155	140	155	140	110
K	1	-	-	-	355	320	290	-	-	-
	2	-	-	-	280	250	230	-	-	-
	3	-	-	-	235	210	190	-	-	-
N	1	-	-	-	-	-	-	-	-	-
	2	-	-	-	-	-	-	-	-	-
	3	-	-	-	-	-	-	-	-	-
S	1	40	35	30	-	-	-	50	40	35
	2	40	35	30	-	-	-	50	40	35
	3	55	40	30	-	-	-	60	50	35
	4	70	55	35	80	60	40	80	60	40
H	1	-	-	-	-	-	-	-	-	-
	2	-	-	-	-	-	-	-	-	-
	3	-	-	-	-	-	-	-	-	-

NOTE: FIRST choice starting speeds are in **bold** type.
As the average chip thickness increases, the speed should be decreased.

Recommended Starting Feeds

■ Recommended Starting Feeds [mm]

Light Machining	General Purpose	Heavy Machining
-----------------	-----------------	-----------------

At 8,00 Axial Depth of Cut (ap)

Insert Geometry	Programmed Feed per Tooth (fz) as a % of Radial Depth of Cut (ae)															Insert Geometry
	5%			10%			20%			30%			40-100%			
ML	0,12	0,37	0,48	0,09	0,27	0,35	0,07	0,20	0,26	0,06	0,17	0,23	0,05	0,16	0,21	ML
MM	0,28	0,70	0,81	0,21	0,50	0,58	0,15	0,38	0,44	0,13	0,33	0,38	0,12	0,30	0,35	MM
MH	0,53	0,70	1,17	0,38	0,50	0,84	0,29	0,38	0,63	0,25	0,33	0,55	0,23	0,30	0,50	MH

At 4,00 Axial Depth of Cut (ap)

Insert Geometry	Programmed Feed per Tooth (fz) as a % of Radial Depth of Cut (ae)															Insert Geometry
	5%			10%			20%			30%			40-100%			
ML	0,14	0,43	0,56	0,10	0,31	0,40	0,08	0,23	0,30	0,07	0,20	0,26	0,06	0,18	0,24	ML
MM	0,33	0,81	0,94	0,24	0,58	0,67	0,18	0,43	0,50	0,16	0,38	0,44	0,14	0,35	0,40	MM
MH	0,62	0,81	1,36	0,44	0,58	0,97	0,33	0,43	0,72	0,29	0,38	0,63	0,27	0,35	0,58	MH

At 2,00 Axial Depth of Cut (ap)

Insert Geometry	Programmed Feed per Tooth (fz) as a % of Radial Depth of Cut (ae)															Insert Geometry
	5%			10%			20%			30%			40-100%			
ML	0,19	0,56	0,73	0,14	0,40	0,53	0,10	0,30	0,40	0,09	0,26	0,34	0,08	0,24	0,32	ML
MM	0,43	1,06	1,24	0,31	0,76	0,89	0,23	0,57	0,66	0,20	0,50	0,57	0,19	0,45	0,53	MM
MH	0,81	1,06	1,79	0,58	0,76	1,28	0,44	0,57	0,95	0,38	0,50	0,83	0,35	0,45	0,76	MH

At 1,00 Axial Depth of Cut (ap)

Insert Geometry	Programmed Feed per Tooth (fz) as a % of Radial Depth of Cut (ae)															Insert Geometry
	5%			10%			20%			30%			40-100%			
ML	0,26	0,77	1,01	0,19	0,55	0,73	0,14	0,41	0,54	0,12	0,36	0,47	0,11	0,33	0,43	ML
MM	0,59	1,46	1,70	0,43	1,04	1,21	0,32	0,78	0,90	0,28	0,68	0,79	0,25	0,62	0,72	MM
MH	1,11	1,46	2,48	0,80	1,04	1,75	0,60	0,78	1,30	0,52	0,68	1,13	0,48	0,62	1,03	MH

NOTE: Use "Light Machining" value as starting feed rate.

Versatile Platform for All Materials and Applications •
M100™ Series Copy Mills



M100

A trusted multipurpose solution for profiling and copy applications, the M100 Series ensures a reliable platform for all of your copy milling, face milling, helical interpolation, and roughing needs. The strong and rigid body design ensures superior results in even the most demanding operations.

- Thick inserts ensure reliability and consistent results.
- Anti-rotation systems in larger iC inserts provide higher MRR capabilities.
- Increased chip evacuation and through tool coolant for enhanced performance.

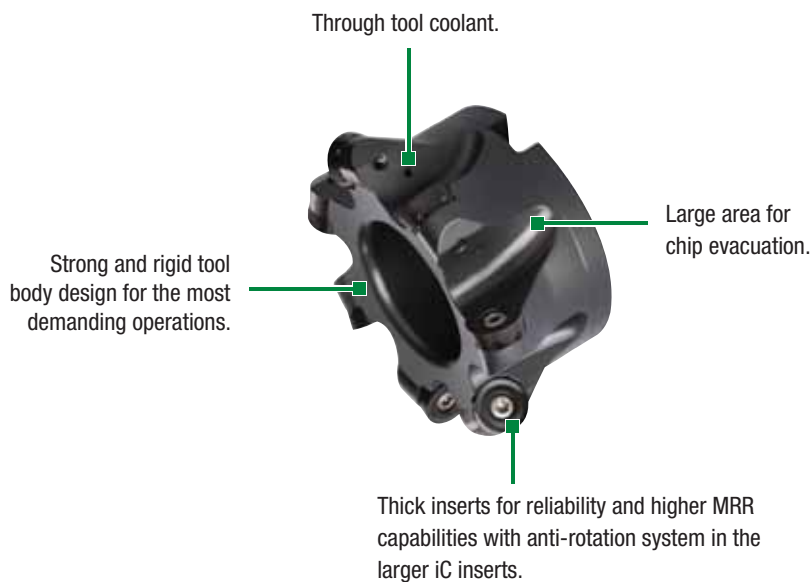

Copy Mills



M100™

Max depth of cut: 6mm

Diameter: 24–125mm

Pages: J42–J67

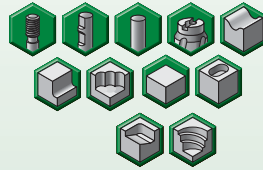
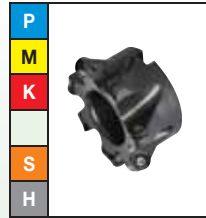

■ Insert Offering



08mm iC
RD Insert Type
Ground and PSTS



10mm iC
RD Insert Type
Ground and PSTS



12mm iC
RD Insert Type
Anti-rotation Feature
Ground and PSTS



16mm iC
RD Insert Type
Anti-rotation Feature
Ground and PSTS



16mm iC
RC Insert Type
Anti-rotation Feature
Ground and PSTS

- General purpose face and copy milling.

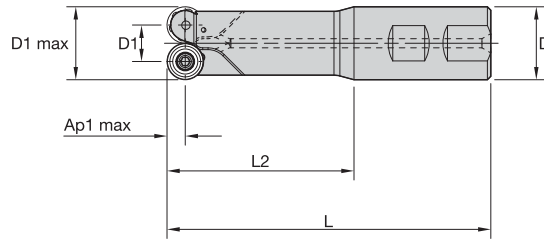
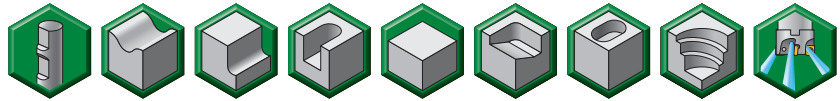

■ Weldon Shanks

order number	catalogue number	D1 max	D1	D	L	L2	Ap1 max	Z	max ramp angle	max RPM	coolant supply	kg
2021331	12391010000	12	4	16	90	42	4,0	1	2.0°	33000	Yes	0,10
2021332	12391010400	12	4	16	130	82	4,0	1	2.0°	33000	Yes	0,10
2021333	12391010600	16	8	16	90	42	4,0	2	7.5°	28000	Yes	0,10
2021334	12391011000	16	8	20	132	82	4,0	2	7.5°	28000	Yes	0,20
2021335	12391011400	16	8	25	183	127	4,0	2	7.5°	28000	Yes	0,40

■ Spare Parts

D1 max	insert screw	Nm	Torx driver
12	12148001300	3,0	12148086600
16	12148001300	3,0	12148086600

NOTE: All spare parts except the insert screws must be ordered separately.

Copy Mills

■ **Insert Selection Guide**

Material Group	Light Machining		General Purpose		Heavy Machining	
	Geometry	Grade	Geometry	Grade	Geometry	Grade
P1-P2	RDMT-T	TN7525	RDMT-T	TN7525	RDMT-T	TN7535
P3-P4	RDMT-T	TN7525	RDMW-T	TN6540	RDMW-T	TN6540
P5-P6	RDMT-T	TN7525	RDMT-T	TN7535	RDMT-T	TN7535
M1-M2	RDHT-T	TN7525	RDHT-T	TN7525	RDMT-T	TN7535
M3	RDHT-T	TN7525	RDHT-T	TN7525	RDMT-T	TN7535
K1-K2	-	-	RDMW-T	TN7535	RDMW-T	TN7535
K3	-	-	RDMW-T	TN7535	RDMW-T	TN7535
N1-N2	-	-	-	-	-	-
N3	-	-	-	-	-	-
S1-S2	-	-	-	-	-	-
S3	-	-	-	-	-	-
S4	-	-	-	-	-	-
H1	-	-	-	-	-	-

iC08 • Inserts

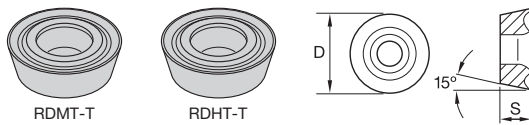

● first choice
○ alternate choice

P	●	○	●	●	●
M	●	○	●	○	○
K	●	○	○	○	○
N	○	○	○	○	○
S	○	○	○	○	○
H	○	○	○	○	○

- Precision ground insert; first choice for light machining.

■ **RDHT-T**

catalogue number	D	S	hm	TN2510	TN6540	TN7525	TN7535
RDHT0802M0T	8,00	2,38	0,09	●	○	○	○

- Precision pressed insert; positive geometry for lower cutting forces.
- First choice for general machining, stainless steel, and high-temp alloys in roughing operations.

■ **RDMT-T**

catalogue number	D	S	hm	TN2510	TN6540	TN7525	TN7535
RDMT0802M0T	8,00	2,38	0,09	●	○	○	○

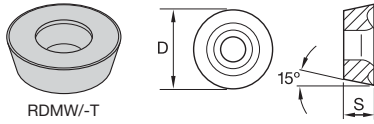

- Precision pressed insert.
- First choice for roughing operations, especially for steel and cast iron.

- first choice
- alternate choice

P	●	○	○	○
M	○	○	○	○
K	○	○	○	○
N	○	○	○	○
S	○	○	○	○
H	○	○	○	○

■ RDMW/-T

catalogue number	D	S	hm	TN2510	TN6540	TN7525	TN7535
RDMW0802M0	8,00	2,38	0,09	2012564	-	-	-
RDMW0802M0T	8,00	2,38	0,09	-	3353278	-	2020727

Recommended Starting Speeds

■ Recommended Starting Speeds [m/min]

Material Group		TN2510			TN6540			TN7525			TN7535		
		1	660	580	540	360	280	240	410	310	280	545	475
P	2	410	370	330	250	190	170	310	250	215	335	305	275
	3	370	330	305	215	170	140	280	215	185	305	275	245
	4	275	260	230	180	130	110	235	170	145	230	210	190
	5	330	300	275	240	180	150	310	235	200	310	275	250
	6	230	205	175	160	120	100	205	160	130	190	160	130
	M	1	270	240	210	130	80	60	245	220	185	245	220
2		245	210	190	80	50	40	220	190	170	220	190	170
3		190	175	150	85	50	40	175	155	140	175	155	140
K	1	420	360	300	220	205	180	380	280	240	355	320	290
	2	360	300	250	175	155	140	325	240	200	280	250	230
	3	300	250	200	155	145	125	240	200	170	235	210	190
N	1	-	-	-	-	-	-	-	-	-	-	-	-
	2	-	-	-	-	-	-	-	-	-	-	-	-
	3	-	-	-	-	-	-	-	-	-	-	-	-
S	1	-	-	-	50	35	30	-	-	-	-	-	-
	2	-	-	-	25	20	10	-	-	-	-	-	-
	3	-	-	-	70	40	30	-	-	-	-	-	-
	4	-	-	-	60	30	25	-	-	-	-	-	-
H	1	145	110	70	-	-	-	-	-	-	-	-	-
	2	145	110	70	-	-	-	-	-	-	-	-	-
	3	115	80	45	-	-	-	-	-	-	-	-	-

NOTE: FIRST choice starting speeds are in **bold** type.
As the average chip thickness increases, the speed should be decreased.

■ Recommended Starting Feeds [mm]

Light Machining	General Purpose	Heavy Machining
-----------------	-----------------	-----------------

At 4,00 Axial Depth of Cut (ap)

Insert Geometry	Programmed Feed per Tooth (fz) as a % of Radial Depth of Cut (ae)															Insert Geometry
	5%			10%			20%			30%			40-100%			
RDMW-	0,19	0,29	0,42	0,14	0,21	0,30	0,10	0,16	0,23	0,09	0,14	0,20	0,08	0,13	0,18	RDMW-
RDHT-T	0,23	0,31	0,63	0,17	0,23	0,45	0,13	0,17	0,34	0,11	0,15	0,29	0,10	0,14	0,27	RDHT-T
RDMT-T	0,23	0,31	0,63	0,17	0,23	0,45	0,13	0,17	0,34	0,11	0,15	0,29	0,10	0,14	0,27	RDMT-T
RDMW-T	0,23	0,42	0,73	0,17	0,30	0,53	0,13	0,23	0,39	0,11	0,20	0,34	0,10	0,18	0,32	RDMW-T

At 2,00 Axial Depth of Cut (ap)

Insert Geometry	Programmed Feed per Tooth (fz) as a % of Radial Depth of Cut (ae)															Insert Geometry
	5%			10%			20%			30%			40-100%			
RDMW-	0,22	0,34	0,48	0,16	0,24	0,35	0,12	0,18	0,26	0,10	0,16	0,23	0,09	0,15	0,21	RDMW-
RDHT-T	0,27	0,36	0,72	0,19	0,26	0,52	0,14	0,20	0,39	0,13	0,17	0,34	0,12	0,16	0,31	RDHT-T
RDMT-T	0,27	0,36	0,72	0,19	0,26	0,52	0,14	0,20	0,39	0,13	0,17	0,34	0,12	0,16	0,31	RDMT-T
RDMW-T	0,27	0,48	0,85	0,19	0,35	0,61	0,14	0,26	0,46	0,13	0,23	0,40	0,12	0,21	0,36	RDMW-T

At 1,00 Axial Depth of Cut (ap)

Insert Geometry	Programmed Feed per Tooth (fz) as a % of Radial Depth of Cut (ae)															Insert Geometry
	5%			10%			20%			30%			40-100%			
RDMW-	0,28	0,44	0,63	0,20	0,32	0,46	0,15	0,24	0,34	0,13	0,21	0,30	0,12	0,19	0,27	RDMW-
RDHT-T	0,35	0,47	0,95	0,25	0,34	0,69	0,19	0,26	0,51	0,17	0,22	0,45	0,15	0,20	0,41	RDHT-T
RDMT-T	0,35	0,47	0,95	0,25	0,34	0,69	0,19	0,26	0,51	0,17	0,22	0,45	0,15	0,20	0,41	RDMT-T
RDMW-T	0,35	0,63	1,12	0,25	0,46	0,80	0,19	0,34	0,60	0,17	0,30	0,52	0,15	0,27	0,48	RDMW-T

At 0,50 Axial Depth of Cut (ap)

Insert Geometry	Programmed Feed per Tooth (fz) as a % of Radial Depth of Cut (ae)															Insert Geometry
	5%			10%			20%			30%			40-100%			
RDMW-	0,39	0,60	0,87	0,28	0,44	0,62	0,21	0,33	0,47	0,18	0,28	0,41	0,17	0,26	0,37	RDMW-
RDHT-T	0,48	0,65	1,31	0,35	0,47	0,94	0,26	0,35	0,70	0,23	0,30	0,61	0,21	0,28	0,56	RDHT-T
RDMT-T	0,48	0,65	1,31	0,35	0,47	0,94	0,26	0,35	0,70	0,23	0,30	0,61	0,21	0,28	0,56	RDMT-T
RDMW-T	0,48	0,87	1,54	0,35	0,62	1,10	0,26	0,47	0,82	0,23	0,41	0,71	0,21	0,37	0,65	RDMW-T

NOTE: Use "Light Machining" value as starting feed rate.

Copy Mills

- General purpose face and copy milling.

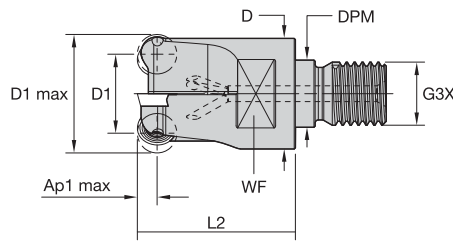
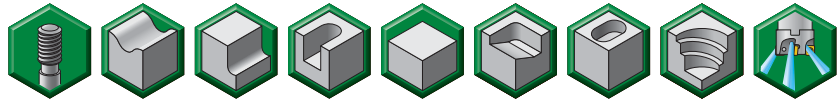

■ Screw-On End Mills

order number	catalogue number	D1 max	D1	D	DPM	G3X	L	L2	WF	Ap1 max	Z	max ramp angle	max RPM	coolant supply	kg
2021375	12391050400	25	15	22	12,5	M12	52	30	19	5,0	2	15.8°	22000	Yes	0,10
2021376	12391050600	30	20	28	17,0	M16	63	40	22	5,0	3	10.3°	20000	Yes	0,20

■ Spare Parts



insert screw

12148036700



Nm

3,0



Torx wrench

12148000600

NOTE: All spare parts except the insert screws must be ordered separately.

- General purpose face and copy milling.

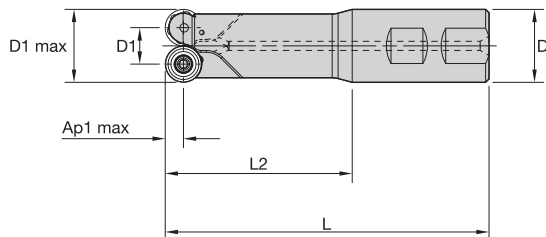
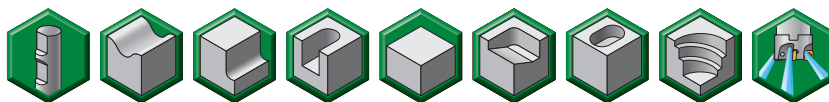

■ **Weldon Shanks**

order number	catalogue number	D1 max	D1	D	L	L2	Ap1 max	Z	max ramp angle	max RPM	coolant supply	kg
2021336	12391011600	20	10	20	92	42	5,0	2	7.8°	25000	Yes	0,20
2021337	12391012000	20	10	25	138	82	5,0	2	8.8°	25000	Yes	0,40
2021338	12391012400	20	10	25	183	127	5,0	2	7.5°	25000	Yes	0,50
2021339	12391012800	26	16	32	142	82	5,0	2	13.5°	22000	Yes	0,60
2021340	12391013200	26	16	32	187	127	5,0	2	14.3°	22000	Yes	0,90

■ **Spare Parts**



insert screw

12148036700



Nm

3,0



Torx driver

12148000600

NOTE: All spare parts except the insert screws must be ordered separately.

■ Insert Selection Guide

Material Group	Light Machining		General Purpose		Heavy Machining	
	Geometry	Grade	Geometry	Grade	Geometry	Grade
P1-P2	RDMT-T	TN6525	RDMT-T	TN6540	RDMT-T	TN6540
P3-P4	RDMT-T	TN6525	RDMW-T	TN6540	RDMW-T	TN6540
P5-P6	RDMT-T	TN7525	RDMT-T	TN7535	RDMW-T	TN7535
M1-M2	RDHT-T	TN7525	RDHT-T	TN7525	RDMT-T	TN6540
M3	RDHT-T	TN7525	RDMT-T	TN6540	RDMT-T	TN6540
K1-K2	RDHW-MH	TN2510	RDHW-MH	TN2510	RDMW-T	TN7535
K3	RDHW-MH	TN2510	RDHW-MH	TN2510	RDMW-T	TN7535
N1-N2	-	-	-	-	-	-
N3	-	-	-	-	-	-
S1-S2	-	-	RDMT-T	TN6540	-	-
S3	-	-	RDMT-T	TN6540	-	-
S4	-	-	RDMT-T	TN6540	RDMT-T	TN6540
H1	RDHW-MH	TN2510	RDHW-MH	TN2510	-	-

Copy Mills

iC10 • Inserts

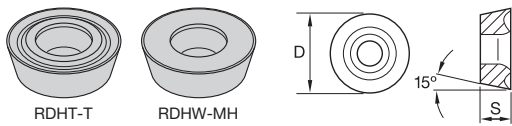

- first choice
- alternate choice

- Precision ground insert; first choice for light machining.

■ RDHT-T

catalogue number	D	S	hm	TN2510	TN6525	TN6540	TN7525	TN7535	TT125
RDHT1003M0T	10,00	3,18	0,14	●	○	○	○	○	○

- Precision ground flat top geometry.

■ RDHW-MH

catalogue number	D	S	hm	TN2510	TN6525	TN6540	TN7525	TN7535	TT125
RDHW1003M0MH	10,00	3,18	0,14	●	○	○	○	○	○

P	●	○	○	○	○	○	○	○	○
M	○	○	○	○	○	○	○	○	○
K	○	○	○	○	○	○	○	○	○
N	○	○	○	○	○	○	○	○	○
S	○	○	○	○	○	○	○	○	○
H	○	○	○	○	○	○	○	○	○

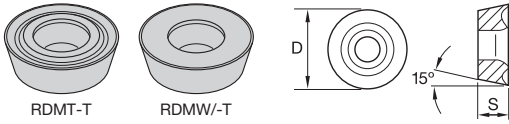

- Precision pressed insert; positive geometry for lower cutting forces.
- First choice for general machining, stainless steel, and high-temp alloys in roughing operations.

● first choice
○ alternate choice

P	●	○	○	○	○	○
M	○	○	○	○	○	○
K	○	○	○	○	○	○
N	○	○	○	○	○	○
S	○	○	○	○	○	○
H	○	○	○	○	○	○

RDMT-T

catalogue number	D	S	hm	TN2510	TN6525	TN6540	TN7525	TN7535	TT125
RDMT1003M0T	10,00	3,18	0,14	-	2957429	2957428	2012534	2276618	-

- Precision pressed insert with flat top geometry.
- First choice for cast iron and high-strength steel.

RDMW/-T

catalogue number	D	S	hm	TN2510	TN6525	TN6540	TN7525	TN7535	TT125
RDMW1003M0	10,00	3,18	0,09	2012572	-	-	-	-	-
RDMW1003M0T	10,00	3,18	0,14	-	3353279	2109381	2020735	2012578	-

Copy Mills

■ Recommended Starting Speeds [m/min]

Material Group		TN2510			TN6525			TN6540			TN7525			TN7535			TT125		
P	1	660	580	540	410	320	280	360	280	240	410	310	280	545	475	445	430	360	300
	2	410	370	330	320	250	215	250	190	170	310	250	215	335	305	275	310	250	215
	3	370	330	305	280	215	185	215	170	140	280	215	185	305	275	245	310	250	215
	4	275	260	230	235	170	145	180	130	110	235	170	145	230	210	190	265	215	180
	5	330	300	275	310	235	200	240	180	150	310	235	200	310	275	250	320	235	200
	6	230	205	175	205	160	130	160	120	100	205	160	130	190	160	130	145	110	90
M	1	270	240	210	190	120	80	130	80	60	245	220	185	245	220	185	480	310	215
	2	245	210	190	120	80	50	80	50	40	220	190	170	220	190	170	325	205	145
	3	190	175	150	125	80	55	85	50	40	175	155	140	175	155	140	320	210	145
K	1	420	360	300	275	245	220	220	205	180	380	280	240	355	320	290	220	185	155
	2	360	300	250	215	190	180	175	155	140	325	240	200	280	250	230	180	145	125
	3	300	250	200	180	160	145	155	145	125	240	200	170	235	210	190	145	125	100
N	1	-	-	-	-	-	-	-	-	-	-	-	-	-	-	-	-	-	-
	2	-	-	-	-	-	-	-	-	-	-	-	-	-	-	-	-	-	-
	3	-	-	-	-	-	-	-	-	-	-	-	-	-	-	-	-	-	-
S	1	-	-	-	-	-	-	50	35	30	-	-	-	-	-	-	-	-	-
	2	-	-	-	-	-	-	25	20	10	-	-	-	-	-	-	-	-	-
	3	-	-	-	-	-	-	70	40	30	-	-	-	-	-	-	-	-	-
	4	-	-	-	-	-	-	60	30	25	-	-	-	-	-	-	-	-	-
H	1	145	110	70	-	-	-	-	-	-	-	-	-	-	-	-	-	-	-
	2	145	110	70	-	-	-	-	-	-	-	-	-	-	-	-	-	-	-
	3	115	80	45	-	-	-	-	-	-	-	-	-	-	-	-	-	-	-

NOTE: FIRST choice starting speeds are in **bold** type.
As the average chip thickness increases, the speed should be decreased.

Copy Mills

■ Recommended Starting Feeds [mm]

Light Machining	General Purpose	Heavy Machining
-----------------	-----------------	-----------------

At 5,00 Axial Depth of Cut (ap)

Insert Geometry	Programmed Feed per Tooth (fz) as a % of Radial Depth of Cut (ae)														Insert Geometry	
	5%			10%			20%			30%			40-100%			
RDHT-T	0,23	0,39	0,65	0,17	0,28	0,47	0,13	0,21	0,35	0,11	0,18	0,31	0,10	0,17	0,28	RDHT-T
RDHW-MH	0,23	0,42	0,88	0,17	0,30	0,63	0,13	0,23	0,47	0,11	0,20	0,41	0,10	0,18	0,38	RDHW-MH
RDMT-T	0,23	0,39	0,65	0,17	0,28	0,47	0,13	0,21	0,35	0,11	0,18	0,31	0,10	0,17	0,28	RDMT-T
RDMW	0,23	0,21	0,61	0,17	0,15	0,44	0,13	0,11	0,33	0,11	0,10	0,28	0,10	0,09	0,26	RDMW
RDMW-T	0,23	0,57	0,88	0,17	0,41	0,63	0,13	0,31	0,47	0,11	0,27	0,41	0,10	0,25	0,38	RDMW-T

At 2,00 Axial Depth of Cut (ap)

Insert Geometry	Programmed Feed per Tooth (fz) as a % of Radial Depth of Cut (ae)														Insert Geometry	
	5%			10%			20%			30%			40-100%			
RDHT-T	0,29	0,49	0,82	0,21	0,35	0,59	0,16	0,26	0,44	0,14	0,23	0,38	0,13	0,21	0,35	RDHT-T
RDHW-MH	0,29	0,53	1,11	0,21	0,38	0,79	0,16	0,28	0,59	0,14	0,25	0,52	0,13	0,23	0,47	RDHW-MH
RDMT-T	0,29	0,49	0,82	0,21	0,35	0,59	0,16	0,26	0,44	0,14	0,23	0,38	0,13	0,21	0,35	RDMT-T
RDMW	0,29	0,26	0,76	0,21	0,19	0,55	0,16	0,14	0,41	0,14	0,12	0,36	0,13	0,11	0,33	RDMW
RDMW-T	0,29	0,71	1,11	0,21	0,51	0,79	0,16	0,38	0,59	0,14	0,33	0,52	0,13	0,31	0,47	RDMW-T

At 1,00 Axial Depth of Cut (ap)

Insert Geometry	Programmed Feed per Tooth (fz) as a % of Radial Depth of Cut (ae)														Insert Geometry	
	5%			10%			20%			30%			40-100%			
RDHT-T	0,39	0,65	1,09	0,28	0,47	0,78	0,21	0,35	0,58	0,18	0,31	0,51	0,17	0,28	0,47	RDHT-T
RDHW-MH	0,39	0,71	1,49	0,28	0,51	1,06	0,21	0,38	0,79	0,18	0,33	0,69	0,17	0,30	0,63	RDHW-MH
RDMT-T	0,39	0,65	1,09	0,28	0,47	0,78	0,21	0,35	0,58	0,18	0,31	0,51	0,17	0,28	0,47	RDMT-T
RDMW	0,39	0,35	1,02	0,28	0,25	0,73	0,21	0,19	0,55	0,18	0,16	0,48	0,17	0,15	0,44	RDMW
RDMW-T	0,39	0,95	1,49	0,28	0,69	1,06	0,21	0,51	0,79	0,18	0,45	0,69	0,17	0,41	0,63	RDMW-T

At 0,50 Axial Depth of Cut (ap)

Insert Geometry	Programmed Feed per Tooth (fz) as a % of Radial Depth of Cut (ae)														Insert Geometry	
	5%			10%			20%			30%			40-100%			
RDHT-T	0,53	0,90	1,52	0,38	0,65	1,08	0,29	0,48	0,81	0,25	0,42	0,70	0,23	0,39	0,64	RDHT-T
RDHW-MH	0,53	0,98	2,07	0,38	0,70	1,47	0,29	0,52	1,09	0,25	0,46	0,95	0,23	0,42	0,87	RDHW-MH
RDMT-T	0,53	0,90	1,52	0,38	0,65	1,08	0,29	0,48	0,81	0,25	0,42	0,70	0,23	0,39	0,64	RDMT-T
RDMW	0,53	0,48	1,41	0,38	0,35	1,01	0,29	0,26	0,75	0,25	0,23	0,65	0,23	0,21	0,60	RDMW
RDMW-T	0,53	1,32	2,07	0,38	0,95	1,47	0,29	0,70	1,09	0,25	0,61	0,95	0,23	0,56	0,87	RDMW-T

NOTE: Use "Light Machining" value as starting feed rate.

Copy Mills

- General purpose face and copy milling.
- Anti-rotation feature for top security.

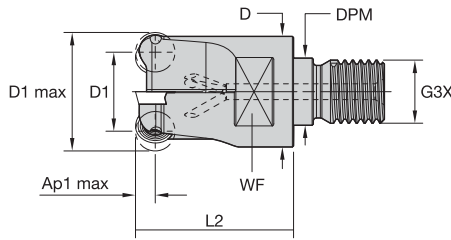
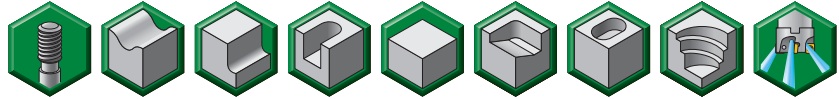

■ Screw-On End Mills

order number	catalogue number	D1 max	D1	D	DPM	G3X	L	L2	WF	Ap1 max	Z	max ramp angle	max RPM	coolant supply	kg
2021374	12391050200	24	12	22	12,5	M12	52	30	19	6,0	2	10.0°	23000	Yes	0,10
2021378	12391051000	35	23	28	17,0	M16	63	40	22	6,0	3	10.8°	19000	Yes	0,20
2021379	12391051200	40	28	28	17,0	M16	63	40	22	6,0	4	8.3°	17000	Yes	0,30

■ Spare Parts



D1 max	insert screw	Nm	Torx wrench
24	12148038800	3,0	12148000600
35	12148038800	3,0	12148000600
40	12148038800	3,0	12148000600

NOTE: All spare parts except the insert screws must be ordered separately.

Copy Mills

- General purpose face and copy milling.
- Anti-rotation feature for top security.

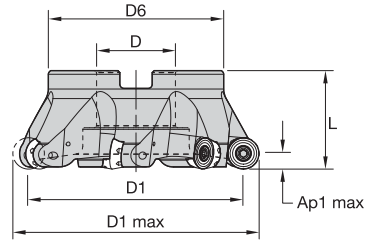

■ **Shell Mills**

order number	catalogue number	D1 max	D1	D	D6	L	Ap1 max	Z	max ramp angle	max RPM	coolant supply	kg
2021342	12391020000	50	38	22	40	40	6,0	4	6.8°	15000	Yes	0,20
2021361	12391024000	52	40	22	40	40	6,0	4	6.5°	15000	Yes	0,20
2021343	12391020200	63	51	27	48	40	6,0	5	4.5°	14000	Yes	0,30
2021344	12391020400	80	68	27	60	50	6,0	6	3.5°	12000	Yes	0,90
2021345	12391020600	100	88	32	78	50	6,0	6	2.5°	11000	No	1,20
2021346	12391020800	125	113	40	89	50	6,0	7	2.0°	10000	No	1,70

■ **Spare Parts**

D1 max	insert screw	Nm	Torx driver	socket-head cap screw	socket-head cap screw with coolant groove
50	12148038800	3,0	12148000600	125.025	MS1234CG
52	12148038800	3,0	12148000600	125.025	MS1234CG
63	12148038800	3,0	12148000600	125.230	MS2038CG
80	12148038800	3,0	12148000600	125.230	MS2038CG
100	12148038800	3,0	12148000600	—	—
125	12148038800	3,0	12148000600	—	—

NOTE: All spare parts except the insert screws must be ordered separately.

Copy Mills

■ Insert Selection Guide

Material Group	Light Machining		General Purpose		Heavy Machining	
	Geometry	Grade	Geometry	Grade	Geometry	Grade
P1-P2	RDMT-TX	TN7525	RDMT-TX	TN6540	RDMT-TX	TN6540
P3-P4	RDMT-TX	TN7525	RDMW-TX	TN6540	RDMW-TX	TN6540
P5-P6	RDMT-TX	TN7525	RDPT-MMX	TN7535	RDPT-MMX	TN7535
M1-M2	RDHT-TX	TN7525	RDMT-TX	TN6540	RDPT-MMX	TN6540
M3	RDHT-TX	TN7525	RDMT-TX	TN6540	RDPT-MMX	TN6540
K1-K2	RDMW-TX	WK15CM	RDMW-TX	WK15CM	RDMW-TX	TN7535
K3	RDHW-MH	TN2510	RDMW-TX	WK15CM	RDMW-TX	WK15CM
N1-N2	-	-	-	-	-	-
N3	-	-	-	-	-	-
S1-S2	-	-	RDMT-TX	TN6540	-	-
S3	-	-	RDMT-TX	TN6540	-	-
S4	-	-	RDMT-TX	TN6540	RDPT-MMX	TN6540
H1	RDHW-MH	TN2510	RDHW-MH	TN2510	-	-

Copy Mills

iC12 • Inserts

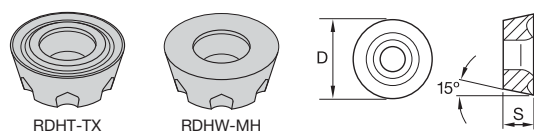

- Precision ground positive geometry for lower cutting forces.
- First choice for general machining, stainless steel, and high-temp alloys.

- first choice
- alternate choice

P	○	●	●	●	●	○	○
M	○	○	○	○	○	○	○
K	○	○	○	○	○	○	○
N	○	○	○	○	○	○	○
S	○	○	○	○	○	○	○
H	○	○	○	○	○	○	○

■ RDHT-TX

catalogue number	number of indexes	D	S	hm	TN2510	TN6525	TN6540	TN7525	TN7535	WK15CM	WS30PM
RDHT1204M0TX	6	12,00	4,76	0,12	○	○	○	○	○	○	○

- Precision ground flat top insert.
- Alternative choice for stable milling operations in high-strength steel and hardened materials.

■ RDHW-MH

catalogue number	number of indexes	D	S	hm	TN2510	TN6525	TN6540	TN7525	TN7535	WK15CM	WS30PM
RDHW1204M0MH	6	12,00	4,76	0,14	○	○	○	○	○	○	○

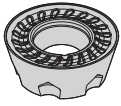

RDPT-MMX

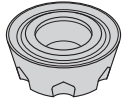

RDMT-TX

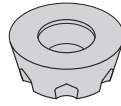

RDMW-TX

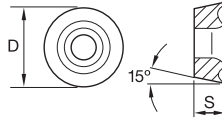

● first choice
○ alternate choice

- Precision pressed insert.
- Improved performance in stainless steel and high-temp alloys.

■ **RDPT-MMX**

catalogue number	number of indexes	D	S	hm	TN2510	TN6525	TN6540	TN7525	TN7535	WK15CM	WS30PM
RDPT1204M0SMMX	6	12,00	4,76	0,18	○	○	○	○	○	○	○

- Precision pressed positive geometry for lower cutting forces.
- First choice for general machining, stainless steel, and high-temp alloys in roughing operations.

■ **RDMT-TX**

catalogue number	number of indexes	D	S	hm	TN2510	TN6525	TN6540	TN7525	TN7535	WK15CM	WS30PM
RDMT1204M0TX	6	12,00	4,76	0,15	●	○	○	○	○	○	○

- Precision pressed insert.
- First choice for roughing operations, especially for steel and cast iron.

■ **RDMW-TX**

catalogue number	number of indexes	D	S	hm	TN2510	TN6525	TN6540	TN7525	TN7535	WK15CM	WS30PM
RDMW1204M0TX	6	12,00	4,76	0,15	○	○	○	○	○	○	○

P	○	●	●	●	●	○	○	○	○	○	○
M	○	○	○	○	○	○	○	○	○	○	○
K	○	○	○	○	○	○	○	○	○	○	○
N	○	○	○	○	○	○	○	○	○	○	○
S	○	○	○	○	○	○	○	○	○	○	○
H	○	○	○	○	○	○	○	○	○	○	○



Copy Mills

■ Recommended Starting Speeds [m/min]

Material Group		TN2510			TN6525			TN6540			TN7525		
P	1	660	580	540	410	320	280	360	280	240	410	310	280
	2	410	370	330	320	250	215	250	190	170	310	250	215
	3	370	330	305	280	215	185	215	170	140	280	215	185
	4	275	260	230	235	170	145	180	130	110	235	170	145
	5	330	300	275	310	235	200	240	180	150	310	235	200
	6	230	205	175	205	160	130	160	120	100	205	160	130
M	1	270	240	210	190	120	80	130	80	60	245	220	185
	2	245	210	190	120	80	50	80	50	40	220	190	170
	3	190	175	150	125	80	55	85	50	40	175	155	140
K	1	420	360	300	275	245	220	220	205	180	380	280	240
	2	360	300	250	215	190	180	175	155	140	325	240	200
	3	300	250	200	180	160	145	155	145	125	240	200	170
N	1	-	-	-	-	-	-	-	-	-	-	-	-
	2	-	-	-	-	-	-	-	-	-	-	-	-
	3	-	-	-	-	-	-	-	-	-	-	-	-
S	1	-	-	-	-	-	-	50	35	30	-	-	-
	2	-	-	-	-	-	-	25	20	10	-	-	-
	3	-	-	-	-	-	-	70	40	30	-	-	-
	4	-	-	-	-	-	-	60	30	25	-	-	-
H	1	145	110	70	-	-	-	-	-	-	-	-	-
	2	145	110	70	-	-	-	-	-	-	-	-	-
	3	115	80	45	-	-	-	-	-	-	-	-	-

Copy Mills

Material Group		TN7535			WK15CM			WS30PM			TTI25		
P	1	545	475	445	-	-	-	-	-	-	430	360	300
	2	335	305	275	-	-	-	-	-	-	310	250	215
	3	305	275	245	-	-	-	-	-	-	310	250	215
	4	230	210	190	-	-	-	-	-	-	265	215	180
	5	310	275	250	-	-	-	-	-	-	320	235	200
	6	190	160	130	-	-	-	-	-	-	145	110	90
M	1	245	220	185	-	-	-	270	240	220	480	310	215
	2	220	190	170	-	-	-	245	215	175	325	205	145
	3	175	155	140	-	-	-	185	160	125	320	210	145
K	1	355	320	290	505	460	410	-	-	-	220	185	155
	2	280	250	230	400	355	330	-	-	-	180	145	125
	3	235	210	190	335	300	275	-	-	-	145	125	100
N	1	-	-	-	-	-	-	-	-	-	-	-	-
	2	-	-	-	-	-	-	-	-	-	-	-	-
	3	-	-	-	-	-	-	-	-	-	-	-	-
S	1	-	-	-	-	-	-	55	50	35	-	-	-
	2	-	-	-	-	-	-	55	50	35	-	-	-
	3	-	-	-	-	-	-	65	55	35	-	-	-
	4	-	-	-	-	-	-	100	70	50	-	-	-
H	1	-	-	-	-	-	-	-	-	-	-	-	-
	2	-	-	-	-	-	-	-	-	-	-	-	-
	3	-	-	-	-	-	-	-	-	-	-	-	-

NOTE: FIRST choice starting speeds are in **bold** type.
As the average chip thickness increases, the speed should be decreased.

■ Recommended Starting Feeds [mm]

Light Machining	General Purpose	Heavy Machining
-----------------	-----------------	-----------------

At 6,00 Axial Depth of Cut (ap)

Insert Geometry	Programmed Feed per Tooth (fz) as a % of Radial Depth of Cut (ae)														Insert Geometry	
	5%			10%			20%			30%			40-100%			
RDHT-TX	0,35	0,33	0,56	0,25	0,24	0,40	0,19	0,18	0,30	0,16	0,16	0,26	0,15	0,14	0,24	RDHT-TX
RDMT-TX	0,35	0,42	0,70	0,25	0,30	0,50	0,19	0,23	0,38	0,16	0,20	0,33	0,15	0,18	0,30	RDMT-TX
RDPT-MMX	0,35	0,57	0,93	0,25	0,41	0,67	0,19	0,31	0,50	0,16	0,27	0,43	0,15	0,25	0,40	RDPT-MMX
RDHW-MH	0,35	0,70	1,08	0,25	0,50	0,78	0,19	0,38	0,58	0,16	0,33	0,50	0,15	0,30	0,46	RDHW-MH
RDMW-TX	0,35	0,70	1,16	0,25	0,50	0,83	0,19	0,38	0,62	0,16	0,33	0,54	0,15	0,30	0,50	RDMW-TX

At 3,00 Axial Depth of Cut (ap)

Insert Geometry	Programmed Feed per Tooth (fz) as a % of Radial Depth of Cut (ae)														Insert Geometry	
	5%			10%			20%			30%			40-100%			
RDHT-TX	0,40	0,38	0,64	0,29	0,28	0,46	0,22	0,21	0,35	0,19	0,18	0,30	0,17	0,17	0,28	RDHT-TX
RDMT-TX	0,40	0,48	0,81	0,29	0,35	0,58	0,22	0,26	0,43	0,19	0,23	0,38	0,17	0,21	0,35	RDMT-TX
RDPT-MMX	0,40	0,66	1,08	0,29	0,48	0,77	0,22	0,36	0,58	0,19	0,31	0,50	0,17	0,29	0,46	RDPT-MMX
RDHW-MH	0,40	0,81	1,25	0,29	0,58	0,90	0,22	0,43	0,67	0,19	0,38	0,58	0,17	0,35	0,53	RDHW-MH
RDMW-TX	0,40	0,81	1,34	0,29	0,58	0,96	0,22	0,43	0,72	0,19	0,38	0,62	0,17	0,35	0,57	RDMW-TX

At 1,50 Axial Depth of Cut (ap)

Insert Geometry	Programmed Feed per Tooth (fz) as a % of Radial Depth of Cut (ae)														Insert Geometry	
	5%			10%			20%			30%			40-100%			
RDHT-TX	0,53	0,50	0,85	0,38	0,36	0,61	0,28	0,27	0,45	0,25	0,24	0,40	0,23	0,22	0,36	RDHT-TX
RDMT-TX	0,53	0,63	1,06	0,38	0,46	0,76	0,28	0,34	0,57	0,25	0,30	0,50	0,23	0,27	0,45	RDMT-TX
RDPT-MMX	0,53	0,87	1,42	0,38	0,63	1,01	0,28	0,47	0,76	0,25	0,41	0,66	0,23	0,37	0,60	RDPT-MMX
RDHW-MH	0,53	1,06	1,65	0,38	0,76	1,18	0,28	0,57	0,88	0,25	0,50	0,76	0,23	0,45	0,70	RDHW-MH
RDMW-TX	0,53	1,06	1,78	0,38	0,76	1,26	0,28	0,57	0,94	0,25	0,50	0,82	0,23	0,45	0,75	RDMW-TX

At 0,75 Axial Depth of Cut (ap)

Insert Geometry	Programmed Feed per Tooth (fz) as a % of Radial Depth of Cut (ae)														Insert Geometry	
	5%			10%			20%			30%			40-100%			
RDHT-TX	0,72	0,69	1,16	0,52	0,50	0,83	0,39	0,37	0,62	0,34	0,32	0,54	0,31	0,30	0,50	RDHT-TX
RDMT-TX	0,72	0,87	1,46	0,52	0,62	1,04	0,39	0,47	0,78	0,34	0,41	0,68	0,31	0,37	0,62	RDMT-TX
RDPT-MMX	0,72	1,20	1,96	0,52	0,86	1,39	0,39	0,64	1,03	0,34	0,56	0,90	0,31	0,51	0,82	RDPT-MMX
RDHW-MH	0,72	1,46	2,29	0,52	1,04	1,62	0,39	0,78	1,20	0,34	0,68	1,04	0,31	0,62	0,95	RDHW-MH
RDMW-TX	0,72	1,46	2,46	0,52	1,04	1,74	0,39	0,78	1,29	0,34	0,68	1,12	0,31	0,62	1,02	RDMW-TX

NOTE: Use "Light Machining" value as starting feed rate.

Copy Mills

- General purpose face and copy milling.
- Anti-rotation feature for top security.

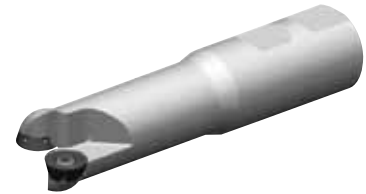
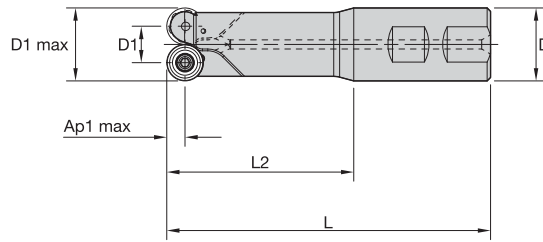
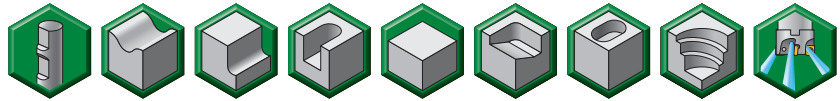

■ Weldon Shanks

order number	catalogue number	D1 max	D1	D	L	L2	Ap1 max	Z	max ramp angle	max RPM	coolant supply	kg
2021341	12391013800	32	16	32	142	82	8,0	2	7.8°	19000	Yes	1,10

■ Spare Parts

D1 max	insert screw	Nm	Torx driver
32	12148007200	4,0	12148007500

NOTE: All spare parts except the insert screws must be ordered separately.

Copy Mills

- General purpose face and copy milling.
- Anti-rotation feature for top security.

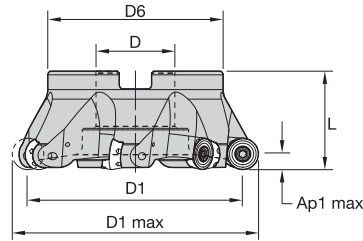
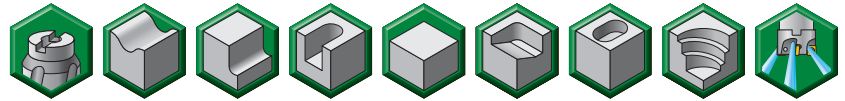

■ **Shell Mills**

order number	catalogue number	D1 max	D1	D	D6	L	Ap1 max	Z	max ramp angle	max RPM	coolant supply	kg
2021347	12391021000	50	34	22	40	40	8,0	4	10.3°	13000	Yes	0,20
2021348	12391021200	63	47	27	48	40	8,0	4	7.0°	12000	Yes	0,30
2021349	12391021400	80	64	27	60	50	8,0	5	4.8°	10000	Yes	0,90
2021350	12391021600	100	84	32	78	50	8,0	6	3.8°	9000	No	1,20
2021351	12391021800	125	109	40	89	50	8,0	7	2.8°	8000	No	1,70

■ **Spare Parts**



D1 max	insert screw	Nm	Torx driver	socket-head cap screw	socket-head cap screw with coolant groove
50	12148007200	4,0	12148007500	125.025	MS1234CG
63	12148007200	4,0	12148007500	125.230	MS2038CG
80	12148007200	4,0	12148007500	125.230	MS2038CG
100	12148007200	4,0	12148007500	—	—
125	12148007200	4,0	12148007500	—	—

NOTE: All spare parts except the insert screws must be ordered separately.

Copy Mills

■ Insert Selection Guide

Material Group	Light Machining		General Purpose		Heavy Machining	
	Geometry	Grade	Geometry	Grade	Geometry	Grade
P1-P2	RDMT-TX	TN6525	RDMT-TX	TN6540	RDMT-TX	TN6540
P3-P4	RDMT-TX	TN6525	RDMW-TX	TN6540	RDMW-TX	TN6540
P5-P6	RDMT-TX	TN7525	RDMT-TX	TN7535	RDMT-TX	TN7535
M1-M2	RDMT-TX	TN6525	RDMT-TX	TN6540	RDMT-TX	TN6540
M3	RDMT-TX	TN6525	RDMT-TX	TN6540	RDMT-TX	TN6540
K1-K2	RDMW-TX	TN2510	RDMW-TX	TN7535	RDMW-TX	TN7535
K3	RDMW-TX	TN2510	RDMW-TX	TN7535	RDMW-TX	TN7535
N1-N2	-	-	-	-	-	-
N3	-	-	-	-	-	-
S1-S2	-	-	RDMT-TX	TN6540	-	-
S3	-	-	RDMT-TX	TN6540	-	-
S4	-	-	RDMT-TX	TN6540	RDMT-TX	TN6540
H1	RDMW-TX	TN2510	RDMW-TX	TN2510	-	-

Copy Mills

iC16 • Inserts

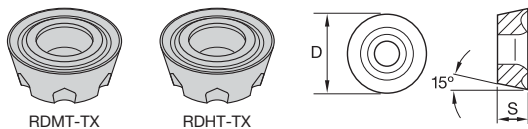

- first choice
- alternate choice

- Precision ground positive geometry for lower cutting forces.
- First choice for general machining, stainless steel, and high-temp alloys.

■ RDHT-TX

catalogue number	D	S	hm	TN2510	TN6525	TN6540	TN7525	TN7535	TT125
RDHT1605M0TX	16,00	5,56	0,12	●	○	○	○	○	○

- Precision pressed positive geometry for lower cutting forces.
- First choice for general machining, stainless steel, and high-temp alloys in roughing operations.

■ RDMT-TX

catalogue number	D	S	hm	TN2510	TN6525	TN6540	TN7525	TN7535	TT125
RDMT1605M0TX	16,00	5,56	0,18	○	○	○	○	○	○

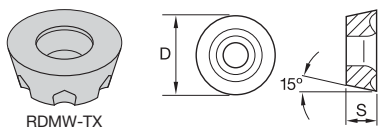

RDMW-TX

- Precision pressed insert.
- First choice for roughing operations, especially for steel and cast iron.

■ **RDMW-TX**

- first choice
- alternate choice

P	●	○	○	○	○	○
M	○	○	○	○	○	○
K	○	○	○	○	○	○
N	○	○	○	○	○	○
S	○	○	○	○	○	○
H	○	○	○	○	○	○

catalogue number	D	S	hm	TN2510	TN6525	TN6540	TN7525	TN7535	TT125
RDMW1605M0TX	16,00	5,56	0,15	○	○	●	○	○	○

■ Recommended Starting Speeds [m/min]

Material Group		TN2510			TN6525			TN6540			TN7525			TN7535			TTI25		
P	1	660	580	540	410	320	280	360	280	240	410	310	280	545	475	445	430	360	300
	2	410	370	330	320	250	215	250	190	170	310	250	215	335	305	275	310	250	215
	3	370	330	305	280	215	185	215	170	140	280	215	185	305	275	245	310	250	215
	4	275	260	230	235	170	145	180	130	110	235	170	145	230	210	190	265	215	180
	5	330	300	275	310	235	200	240	180	150	310	235	200	310	275	250	320	235	200
	6	230	205	175	205	160	130	160	120	100	205	160	130	190	160	130	145	110	90
M	1	270	240	210	190	120	80	130	80	60	245	220	185	245	220	185	480	310	215
	2	245	210	190	120	80	50	80	50	40	220	190	170	220	190	170	325	205	145
	3	190	175	150	125	80	55	85	50	40	175	155	140	175	155	140	320	210	145
K	1	420	360	300	275	245	220	220	205	180	380	280	240	355	320	290	220	185	155
	2	360	300	250	215	190	180	175	155	140	325	240	200	280	250	230	180	145	125
	3	300	250	200	180	160	145	155	145	125	240	200	170	235	210	190	145	125	100
N	1	-	-	-	-	-	-	-	-	-	-	-	-	-	-	-	-	-	-
	2	-	-	-	-	-	-	-	-	-	-	-	-	-	-	-	-	-	-
	3	-	-	-	-	-	-	-	-	-	-	-	-	-	-	-	-	-	-
S	1	-	-	-	-	-	-	50	35	30	-	-	-	-	-	-	-	-	-
	2	-	-	-	-	-	-	25	20	10	-	-	-	-	-	-	-	-	-
	3	-	-	-	-	-	-	70	40	30	-	-	-	-	-	-	-	-	-
	4	-	-	-	-	-	-	60	30	25	-	-	-	-	-	-	-	-	-
H	1	145	110	70	-	-	-	-	-	-	-	-	-	-	-	-	-	-	-
	2	145	110	70	-	-	-	-	-	-	-	-	-	-	-	-	-	-	-
	3	115	80	45	-	-	-	-	-	-	-	-	-	-	-	-	-	-	-

NOTE: FIRST choice starting speeds are in **bold** type.
As the average chip thickness increases, the speed should be decreased.

Copy Mills

■ Recommended Starting Feeds [mm]

Light Machining	General Purpose	Heavy Machining
-----------------	-----------------	-----------------

At 8,00 Axial Depth of Cut (ap)

Insert Geometry	Programmed Feed per Tooth (fz) as a % of Radial Depth of Cut (ae)															Insert Geometry
	5%			10%			20%			30%			40-100%			
RDHX-TX	0,11	0,35	0,70	0,08	0,25	0,50	0,06	0,19	0,38	0,05	0,16	0,33	0,05	0,15	0,30	RDHX-TX
RDMT-TX	0,23	0,42	0,84	0,17	0,30	0,60	0,13	0,23	0,45	0,11	0,20	0,39	0,10	0,18	0,36	RDMT-TX
RDMW-TX	0,23	0,52	1,05	0,17	0,38	0,76	0,13	0,28	0,56	0,11	0,25	0,49	0,10	0,23	0,45	RDMW-TX

At 4,00 Axial Depth of Cut (ap)

Insert Geometry	Programmed Feed per Tooth (fz) as a % of Radial Depth of Cut (ae)															Insert Geometry
	5%			10%			20%			30%			40-100%			
RDHX-TX	0,13	0,40	0,81	0,10	0,29	0,58	0,07	0,22	0,43	0,06	0,19	0,38	0,06	0,17	0,35	RDHX-TX
RDMT-TX	0,27	0,48	0,97	0,19	0,35	0,70	0,14	0,26	0,52	0,13	0,23	0,45	0,12	0,21	0,42	RDMT-TX
RDMW-TX	0,27	0,60	1,22	0,19	0,44	0,87	0,14	0,33	0,65	0,13	0,28	0,57	0,12	0,26	0,52	RDMW-TX

At 2,00 Axial Depth of Cut (ap)

Insert Geometry	Programmed Feed per Tooth (fz) as a % of Radial Depth of Cut (ae)															Insert Geometry
	5%			10%			20%			30%			40-100%			
RDHX-TX	0,17	0,53	1,06	0,13	0,38	0,76	0,09	0,28	0,57	0,08	0,25	0,50	0,08	0,23	0,45	RDHX-TX
RDMT-TX	0,35	0,63	1,28	0,25	0,46	0,92	0,19	0,34	0,68	0,17	0,30	0,59	0,15	0,27	0,54	RDMT-TX
RDMW-TX	0,35	0,79	1,61	0,25	0,57	1,15	0,19	0,43	0,85	0,17	0,37	0,74	0,15	0,34	0,68	RDMW-TX

At 1,00 Axial Depth of Cut (ap)

Insert Geometry	Programmed Feed per Tooth (fz) as a % of Radial Depth of Cut (ae)															Insert Geometry
	5%			10%			20%			30%			40-100%			
RDHX-TX	0,24	0,72	1,46	0,17	0,52	1,04	0,13	0,39	0,78	0,11	0,34	0,68	0,10	0,31	0,62	RDHX-TX
RDMT-TX	0,48	0,87	1,76	0,35	0,62	1,26	0,26	0,47	0,93	0,23	0,41	0,81	0,21	0,37	0,74	RDMT-TX
RDMW-TX	0,48	1,09	2,22	0,35	0,78	1,58	0,26	0,58	1,17	0,23	0,51	1,02	0,21	0,46	0,93	RDMW-TX

NOTE: Use "Light Machining" value as starting feed rate.

Copy Mills

- General purpose face and copy milling.
- Anti-rotation feature for top security.

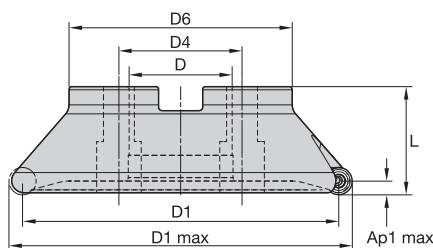
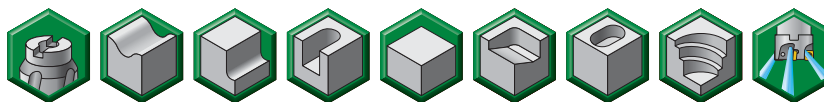

■ Shell Mills

order number	catalogue number	D1 max	D1	D	D4	D6	L	Ap1 max	Z	max ramp angle	max RPM	coolant supply	kg
2021358	12391023400	50	34	22	—	40	40	8,0	4	6.0°	13000	Yes	0,20
2021359	12391023600	52	36	22	—	40	40	8,0	4	5.8°	13000	Yes	0,30
2021357	12391023200	63	47	27	—	48	40	8,0	5	4.0°	12000	Yes	0,20
2021360	12391023800	66	50	27	—	48	40	8,0	5	3.8°	12000	Yes	0,30
2021352	12391022000	80	64	27	—	60	50	8,0	6	2.8°	10000	Yes	0,90
2021353	12391022200	100	84	32	—	78	50	8,0	7	2.3°	9000	No	1,20
2021354	12391022400	125	109	40	—	89	50	8,0	8	1.8°	8000	No	1,80
2021355	12391022600	160	144	40	67	90	63	8,0	9	1.3°	7000	No	2,90
2021356	12391022800	200	184	60	102	130	63	8,0	11	0.8°	6000	No	0,30

■ Spare Parts



D1 max	insert screw	Nm	Torx driver	socket-head cap screw	socket-head cap screw with coolant groove
50	12148007200	4,0	12148007500	125.025	MS1234CG
52	12148007200	4,0	12148007500	125.025	MS1234CG
63	12148007200	4,0	12148007500	125.230	MS2038CG
66	12148007200	4,0	12148007500	125.230	MS2038CG
80	12148007200	4,0	12148007500	125.230	MS2038CG
100	12148007200	4,0	12148007500	—	—
125	12148007200	4,0	12148007500	—	—
160	12148007200	4,0	12148007500	—	—
200	12148007200	4,0	12148007500	—	—

NOTE: All spare parts except the insert screws must be ordered separately.

■ **Insert Selection Guide**

Material Group	Light Machining		General Purpose		Heavy Machining	
	Geometry	Grade	Geometry	Grade	Geometry	Grade
P1-P2	...TX	TN6525	...43	TN6540	...43	TN6540
P3-P4	...TX	TN6525	...TX	TN6540	...43	TN6540
P5-P6	...TX	TN6525	...TX	TN7535	...TX	TN7535
M1-M2	...TX	TN6525	...TX	TN6540	...TX	TN6540
M3	...TX	TN6525	...TX	TN6540	...TX	TN6540
K1-K2	...43	TN2510	...TX	WK15CM	...TX	WK15CM
K3	...TX	TN6525	...TX	WK15CM	...TX	WK15CM
N1-N2	-	-	-	-	-	-
N3	-	-	-	-	-	-
S1-S2	-	-	-	-	-	-
S3	-	-	-	-	-	-
S4	...43	TN6540	...TX	TN6540	...TX	TN6540
H1	-	-	...TX	TN2510	-	-

iC16 • Inserts

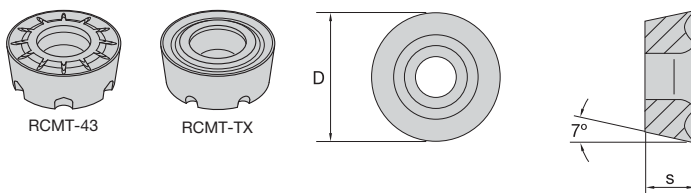

- Optimised geometry providing excellent chip control, even at lower depth of cut.

■ **RCMT-43**

catalogue number	D	S	hm	Material Group				
				TN2510	TN6525	TN6540	TN7525	TN7535
RCMT1606M043M	16,00	6,35	0,20	●	○	○	○	○

- Precision pressed positive geometry for lower cutting forces.
- First choice for general machining, stainless steel, and high-temp alloys in roughing operations.

■ **RCMT-TX**

catalogue number	D	S	hm	Material Group				
				TN2510	TN6525	TN6540	TN7525	TN7535
RCMT1606M0TX	16,00	6,35	0,24	○	○	○	○	○

■ Recommended Starting Speeds [m/min]

Material Group		TN2510			TN6525			TN6540			TN7525			TN7535			WK15CM		
P	1	660	580	540	410	320	280	360	280	240	410	310	280	545	475	445	-	-	-
	2	410	370	330	320	250	215	250	190	170	310	250	215	335	305	275	-	-	-
	3	370	330	305	280	215	185	215	170	140	280	215	185	305	275	245	-	-	-
	4	275	260	230	235	170	145	180	130	110	235	170	145	230	210	190	-	-	-
	5	330	300	275	310	235	200	240	180	150	310	235	200	310	275	250	-	-	-
	6	230	205	175	205	160	130	160	120	100	205	160	130	190	160	130	-	-	-
M	1	270	240	210	190	120	80	130	80	60	245	220	185	245	220	185	-	-	-
	2	245	210	190	120	80	50	80	50	40	220	190	170	220	190	170	-	-	-
	3	190	175	150	125	80	55	85	50	40	175	155	140	175	155	140	-	-	-
K	1	420	360	300	275	245	220	220	205	180	380	280	240	355	320	290	505	460	410
	2	360	300	250	215	190	180	175	155	140	325	240	200	280	250	230	400	355	330
	3	300	250	200	180	160	145	155	145	125	240	200	170	235	210	190	335	300	275
N	1	-	-	-	-	-	-	-	-	-	-	-	-	-	-	-	-	-	-
	2	-	-	-	-	-	-	-	-	-	-	-	-	-	-	-	-	-	-
	3	-	-	-	-	-	-	-	-	-	-	-	-	-	-	-	-	-	-
S	1	-	-	-	-	-	-	50	35	30	-	-	-	-	-	-	-	-	-
	2	-	-	-	-	-	-	25	20	10	-	-	-	-	-	-	-	-	-
	3	-	-	-	-	-	-	70	40	30	-	-	-	-	-	-	-	-	-
	4	-	-	-	-	-	-	60	30	25	-	-	-	-	-	-	-	-	-
H	1	145	110	70	-	-	-	-	-	-	-	-	-	-	-	-	-	-	-
	2	145	110	70	-	-	-	-	-	-	-	-	-	-	-	-	-	-	-
	3	115	80	45	-	-	-	-	-	-	-	-	-	-	-	-	-	-	-

NOTE: FIRST choice starting speeds are in **bold** type.
As the average chip thickness increases, the speed should be decreased.

Copy Mills

■ Recommended Starting Feeds [mm]

Light Machining	General Purpose	Heavy Machining
-----------------	-----------------	-----------------

At 8,00 Axial Depth of Cut (ap)

Insert Geometry	Programmed Feed per Tooth (fz) as a % of Radial Depth of Cut (ae)															Insert Geometry
	5%			10%			20%			30%			40-100%			
...43	0,46	0,60	0,93	0,33	0,44	0,67	0,25	0,33	0,50	0,22	0,28	0,44	0,20	0,26	0,40	...43
...TX	0,46	0,70	1,12	0,33	0,50	0,81	0,25	0,38	0,60	0,22	0,33	0,52	0,20	0,30	0,48	...TX

At 4,00 Axial Depth of Cut (ap)

Insert Geometry	Programmed Feed per Tooth (fz) as a % of Radial Depth of Cut (ae)															Insert Geometry
	5%			10%			20%			30%			40-100%			
...43	0,54	0,70	1,08	0,39	0,50	0,78	0,29	0,38	0,58	0,25	0,33	0,50	0,23	0,30	0,46	...43
...TX	0,54	0,81	1,30	0,39	0,58	0,93	0,29	0,43	0,69	0,25	0,38	0,61	0,23	0,35	0,55	...TX

At 2,00 Axial Depth of Cut (ap)

Insert Geometry	Programmed Feed per Tooth (fz) as a % of Radial Depth of Cut (ae)															Insert Geometry
	5%			10%			20%			30%			40-100%			
...43	0,70	0,92	1,42	0,51	0,66	1,02	0,38	0,49	0,76	0,33	0,43	0,66	0,30	0,39	0,60	...43
...TX	0,70	1,06	1,72	0,51	0,76	1,23	0,38	0,57	0,91	0,33	0,50	0,79	0,30	0,45	0,73	...TX

At 1,00 Axial Depth of Cut (ap)

Insert Geometry	Programmed Feed per Tooth (fz) as a % of Radial Depth of Cut (ae)															Insert Geometry
	5%			10%			20%			30%			40-100%			
...43	0,96	1,26	1,97	0,69	0,90	1,40	0,52	0,67	1,04	0,45	0,59	0,90	0,41	0,54	0,83	...43
...TX	0,96	1,46	2,38	0,69	1,04	1,68	0,52	0,78	1,25	0,45	0,68	1,08	0,41	0,62	0,99	...TX

NOTE: Use "Light Machining" value as starting feed rate.

For Secure and Rigid Insert Clamping •

M270™ Series

M270



With precision-engineered ball nose, toroidal, and new high-feed inserts, the M270 Series provides the highest accuracy and insert stability for exceptional reliability and performance.

- Ball nose and toroidal tools for semi-finishing through finishing.
- Performance-boosting High-Feed (HF) inserts offered standard.
- V-shaped contact faces enable maximum stability and accuracy.

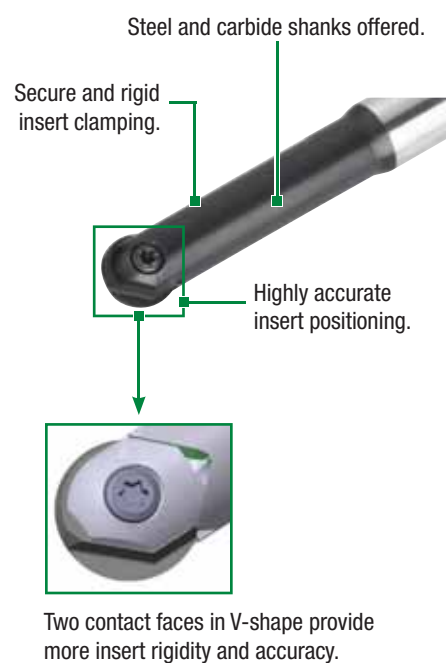
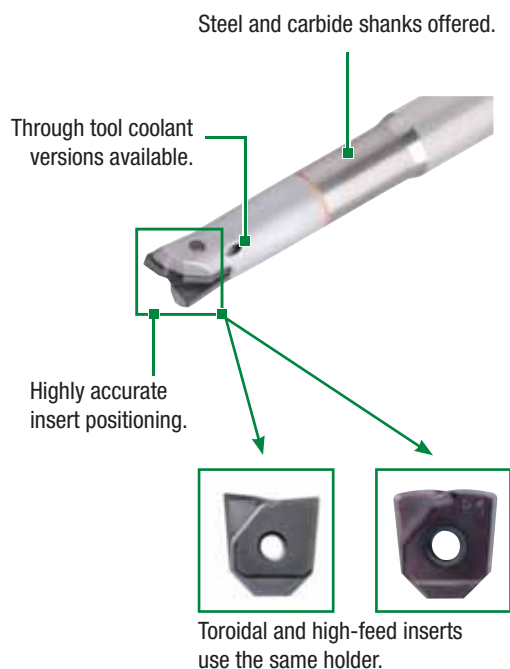

Copy Mills

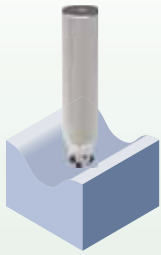

M270™ Ball Nose

Max depth of cut: 5–16mm

Diameter: 10–32mm

Pages: J70–J85

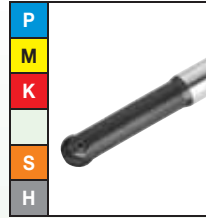

M270 Toroidal

Max depth of cut: 0,3–4mm

Diameter: 10–20mm

Pages: J86–J91

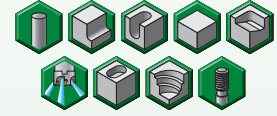
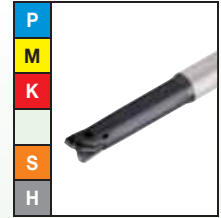

M270 High Feed

Max depth of cut: 0,6–1,1mm

Diameter: 10–20mm

Pages: J92–J98

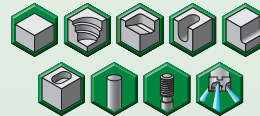
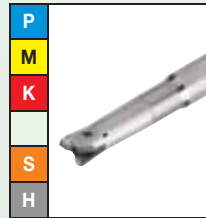

■ Insert Offering



**Ball nose inserts
BF/BR**



**Toroidal inserts
TF**



**High-Feed inserts
HF**

- Rough, semi-finishing, and finishing with one system.
- Through tool coolant.
- Secure and rigid insert clamping.

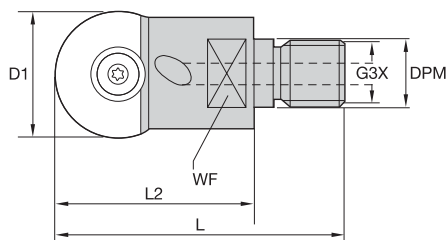

■ Ball Nose • Screw-On End Mills

order number	catalogue number	D1	DPM	G3X	L	L2	WF	Z	Z U	inserts	max RPM	coolant supply	kg
2243624	M270BD010M08	10	8,5	M8	42	25	10,0	1	2	M270B.10	57000	Yes	0,05
2243625	M270BD012M08	12	8,5	M8	42	25	10,0	1	2	M270B.12	55000	Yes	0,05
2243626	M270BD016M08	16	8,5	M8	47	30	10,0	1	2	M270B.16	53000	Yes	0,05
2243627	M270BD020M10	20	10,5	M10	59	40	14,0	1	2	M270B.20	52000	Yes	0,10
2243628	M270BD025M12	25	12,5	M12	72	50	19,0	1	2	M270B.25	50000	Yes	0,10
2243629	M270BD032M16	32	17,0	M16	73	50	22,0	1	2	M270B.32	46000	Yes	0,20

NOTE: ZU = Effective teeth.
Z = number of pocket seats.

■ Spare Parts



D1	insert screw	Nm	Torx driver
10	12748610500	2,0	12148788900
12	12748610600	2,0	12148788900
16	12748610700	5,0	12148099300
20	12748610800	5,0	12148099300
25	12748610900	7,0	12148086800
32	12748611000	7,0	12146006300

NOTE: All spare parts except the insert screws must be ordered separately.

- Rough, semi-finishing, and finishing with one system.
- Secure and rigid insert clamping.

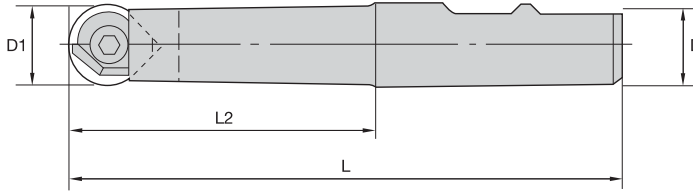
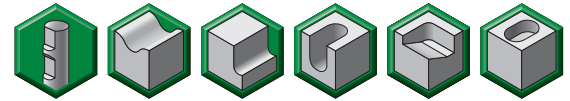

■ **Ball Nose • Weldon® Shanks**

order number	catalogue number	D1	D	L	L2	Z	Z U	inserts	max RPM	coolant supply	kg
2243618	M270BD010B12L90	10	12	90	45	1	2	M270B.10	57000	No	0,10
2243619	M270BD012B12L95	12	12	95	50	1	2	M270B.12	55000	No	0,10
2243620	M270BD016B16L105	16	16	105	57	1	2	M270B.16	53000	No	0,10
2243621	M270BD020B20L120	20	20	120	70	1	2	M270B.20	52000	No	0,20
2243622	M270BD025B25L145	25	25	145	89	1	2	M270B.25	50000	No	0,40
2243623	M270BD032B32L155	32	32	155	95	1	2	M270B.32	46000	No	0,80

NOTE: ZU = Effective teeth
Z = number of pocket seats

■ **Spare Parts**



D1	insert screw	Nm	Torx driver
10	12748610500	2,0	12148788900
12	12748610600	2,0	12148788900
16	12748610700	5,0	12148099300
20	12748610800	5,0	12148099300
25	12748610900	7,0	12148086800
32	12748611000	7,0	12146006300

NOTE: All spare parts except the insert screws must be ordered separately.

Copy Mills

- Rough, semi-finishing, and finishing with one system.
- Secure and rigid insert clamping.

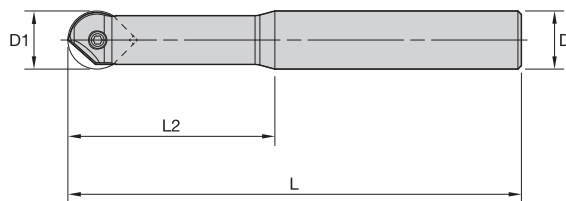
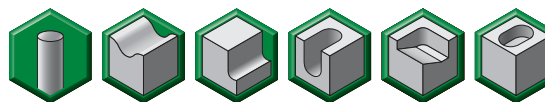

■ Ball Nose • Cylindrical Shanks

order number	catalogue number	D1	D	L	L2	Z	Z U	inserts	max RPM	coolant supply	kg
2243613	M270BD010A12L140	10	12	140	45	1	2	M270B.10	57000	No	0,10
2243614	M270BD012A12L145	12	12	145	50	1	2	M270B.12	55000	No	0,10
2067470	M270BD016A16L155	16	16	155	57	1	2	M270B.16	53000	No	0,20
2243615	M270BD020A20L170	20	20	170	70	1	2	M270B.20	52000	No	0,40
2243616	M270BD025A25L195	25	25	195	89	1	2	M270B.25	50000	No	0,60
2243617	M270BD032A32L205	32	32	205	95	1	2	M270B.32	46000	No	1,10

NOTE: ZU = Effective teeth.
Z = number of pocket seats.

■ Spare Parts



D1	insert screw	Nm	Torx driver
10	12748610500	2,0	12148788900
12	12748610600	2,0	12148788900
16	12748610700	5,0	12148099300
20	12748610800	5,0	12148099300
25	12748610900	7,0	12148086800
32	12748611000	7,0	12146006300

NOTE: All spare parts except the insert screws must be ordered separately.

- Rough, semi-finishing, and finishing with one system.
- Through tool coolant.
- Carbide shank to improve rigidity.

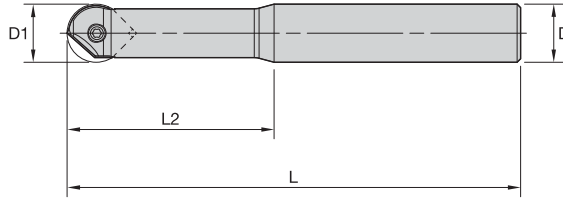

Ball Nose • Carbide Cylindrical Shanks

order number	catalogue number	D1	D	L	L2	Z	Z U	inserts	max RPM	coolant supply	kg
2424550	M270BD010A12L140C	10	12	140	45	1	2	M270B.10	57000	Yes	0,20
2424587	M270BD012A12L145C	12	12	145	50	1	2	M270B.12	55000	Yes	0,20
2424634	M270BD016A16L155C	16	16	155	57	1	2	M270B.16	53000	Yes	0,40
2639257	M270BD020A20L170C	20	20	170	70	1	2	M270B.20	52000	Yes	0,65

NOTE: ZU = Effective teeth.
Z = number of pocket seats.

Spare Parts



D1	insert screw	Nm	Torx driver
10	12748610500	2,0	12148788900
12	12748610600	2,0	12148788900
16	12748610700	5,0	12148099300
20	12748610800	5,0	12148099300

NOTE: All spare parts except the insert screws must be ordered separately.

Copy Mills

■ Insert Selection Guide • .B..10

Material Group	Light Machining		General Purpose		Heavy Machining	
	Geometry	Grade	Geometry	Grade	Geometry	Grade
P1-P2	BF	TN2505	BR	TN7535	BR	TN7535
P3-P4	BF	TN2505	BR	TN7535	BR	TN7535
P5-P6	BF	TN2505	BR	TN7535	BR	TN7535
M1-M2	BR	TN7535	BR	TN7535	BR	TN7535
M3	BR	TN7535	BR	TN7535	BR	TN7535
K1-K2	BF	TN2505	BR	TN7535	BR	TN7535
K3	BF	TN2505	BR	TN7535	BR	TN7535
N1-N2	-	-	-	-	-	-
N3	-	-	-	-	-	-
S1-S2	-	-	-	-	-	-
S3	-	-	-	-	-	-
S4	-	-	-	-	-	-
H1	BF	TN2505	BF	TN2505	-	TN2510

■ Insert Selection Guide • .B..12

Material Group	Light Machining		General Purpose		Heavy Machining	
	Geometry	Grade	Geometry	Grade	Geometry	Grade
P1-P2	BF	TN2505	BR	TN7535	BR	TN7535
P3-P4	BF	TN2505	BR	TN7535	BR	TN7535
P5-P6	BF	TN2505	BR	TN7535	BR	TN7535
M1-M2	BR	TN7535	BR	TN7535	BR	TN7535
M3	BR	TN7535	BR	TN7535	BR	TN7535
K1-K2	BF	TN2505	BR	TN2510	BR	TN7535
K3	BF	TN2505	BR	TN2510	BR	TN7535
N1-N2	-	-	-	-	-	-
N3	-	-	-	-	-	-
S1-S2	-	-	-	-	-	-
S3	-	-	-	-	-	-
S4	-	-	-	-	-	-
H1	BF	TN2505	BF	TN2505	BR	TN2510

■ Insert Selection Guide • .B..16

Material Group	Light Machining		General Purpose		Heavy Machining	
	Geometry	Grade	Geometry	Grade	Geometry	Grade
P1-P2	BF	TN6525	BR	TN7535	BR	TN7535
P3-P4	BF	TN6525	BR	TN7535	BR	TN7535
P5-P6	BF	TN6525	BR	TN7535	BR	TN7535
M1-M2	BF	TN6525	BF	TN6525	BR	TN7535
M3	BF	TN6525	BF	TN6525	BR	TN7535
K1-K2	BF	TN2505	BR	TN7535	BR	TN7535
K3	BF	TN2505	BR	TN7535	BR	TN7535
N1-N2	-	-	-	-	-	-
N3	-	-	-	-	-	-
S1-S2	-	-	-	-	-	-
S3	-	-	-	-	-	-
S4	BF	TN2505	-	-	-	-
H1	BF	TN2505	BF	TN2505	BR	TN2510

Copy Mills

■ Insert Selection Guide • .B..20

Material Group	Light Machining		General Purpose		Heavy Machining	
	Geometry	Grade	Geometry	Grade	Geometry	Grade
P1-P2	BF	TN6540	BF	TN6540	BF	TN6540
P3-P4	BF	TN6540	BF	TN6540	BF	TN7535
P5-P6	BF	TN6540	BF	TN7535	BF	TN7535
M1-M2	BF	TN6540	BF	TN6540	BF	TN7535
M3	BF	TN6540	BF	TN6540	BF	TN7535
K1-K2	BR	TN2505	BR	TN2505	-	-
K3	BR	TN2505	BR	TN2505	-	-
N1-N2	-	-	-	-	-	-
N3	-	-	-	-	-	-
S1-S2	-	-	BF	TN6540	-	-
S3	-	-	BF	TN6540	-	-
S4	-	-	BF	TN6540	-	-
H1	-	-	BR	TN2505	-	TN2510

■ Insert Selection Guide • .B..25

Material Group	Light Machining		General Purpose		Heavy Machining	
	Geometry	Grade	Geometry	Grade	Geometry	Grade
P1-P2	BF	TN2510	BR	TN7525	BR	TN7535
P3-P4	BF	TN2510	BR	TN7525	BR	TN7535
P5-P6	BF	TN2510	BR	TN7525	BR	TN7535
M1-M2	BF	TN2510	BF	TN2510	BR	TN7535
M3	BF	TN2510	BF	TN2510	BR	TN7535
K1-K2	BF	TN2510	BF	TN2510	BR	TN7535
K3	BF	TN2505	BF	TN2510	BR	TN7535
N1-N2	-	-	-	-	-	-
N3	-	-	-	-	-	-
S1-S2	BF	TN2510	-	-	-	-
S3	BF	TN2510	-	-	-	-
S4	BF	TN2505	BR	TN7535	-	-
H1	BF	TN2505	BF	TN2510	BR	TN2510

■ Insert Selection Guide • .B..32

Material Group	Light Machining		General Purpose		Heavy Machining	
	Geometry	Grade	Geometry	Grade	Geometry	Grade
P1-P2	BF	TN2510	BR	TN7525	BR	TN7535
P3-P4	BF	TN2510	BR	TN7525	BR	TN7535
P5-P6	BF	TN2510	BR	TN7525	BR	TN7535
M1-M2	BF	TN2510	BF	TN2510	BR	TN7535
M3	BF	TN2510	BF	TN2510	BR	TN7535
K1-K2	BF	TN2510	BF	TN2510	BR	TN7535
K3	BF	TN2505	BF	TN2510	BR	TN7535
N1-N2	-	-	-	-	-	-
N3	-	-	-	-	-	-
S1-S2	BF	TN2510	-	-	-	-
S3	BF	TN2510	-	-	-	-
S4	BF	TN2505	BR	TN7535	-	-
H1	BF	TN2505	BF	TN2510	BR	TN2510

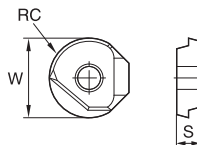
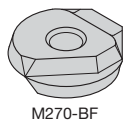

- -BF geometry is the first choice for all finishing and light operations.

■ M270 BF

- first choice
- alternate choice

P	●	○	○	○	○	○	○	○	○
M	●	○	○	○	○	○	○	○	○
K	●	○	○	○	○	○	○	○	○
N	○	○	○	○	○	○	○	○	○
S	○	○	○	○	○	○	○	○	○
H	○	○	○	○	○	○	○	○	○

Copy Mills

catalogue number	W	S	RC	hm	TN2505	TN2510	TN6525	TN6540	TN7525	TN7535
M270BF10	10,00	2,38	5,00	0,08	2012698	2012700	2012718	2012720	2012728	2012730
M270BF12	12,00	3,18	6,00	0,08	2012718	2012720	2012728	2012730	2957538	2957541
M270BF16	16,00	4,76	8,00	0,08	2012748	2012750	2012758	2012760	2957542	2957541
M270BF20	20,00	4,76	10,00	0,10	2012748	2012750	2012758	2012760	2957542	2957541
M270BF25	25,00	4,76	12,50	0,10	2012778	2012780	2012778	2012780	2012778	2012780
M270BF32	32,00	4,76	16,00	0,10	2012778	2012780	2012778	2012780	2012778	2012780

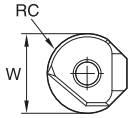
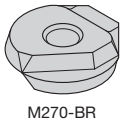

M270-BR

- -BR geometry is the first choice for all semi-finishing and medium-duty applications.

- first choice
- alternate choice

P	●	○	○	○	○	○	○	○	○	○	○
M	●	○	○	○	○	○	○	○	○	○	○
K	●	○	○	○	○	○	○	○	○	○	○
N	●	○	○	○	○	○	○	○	○	○	○
S	●	○	○	○	○	○	○	○	○	○	○
H	●	○	○	○	○	○	○	○	○	○	○

■ M270 BR

catalogue number	W	S	RC	hm	TN2505	TN2510	TN6525	TN6540	TN7525	TN7535
M270BR10	10,00	2,38	5,00	0,08	●	○	○	○	○	○
M270BR12	12,00	3,18	6,00	0,08	●	○	○	○	○	○
M270BR16	16,00	4,76	8,00	0,08	●	○	○	○	○	○
M270BR20	20,00	4,76	10,00	0,10	●	○	○	○	○	○
M270BR25	25,00	4,76	12,50	0,10	●	○	○	○	○	○
M270BR32	32,00	4,76	16,00	0,10	●	○	○	○	○	○



Copy Mills

■ Recommended Starting Speeds [m/min]

Material Group		TN2505			TN2510			TN6525			TN6540		
P	1	550	420	360	660	580	540	410	320	280	360	280	240
	2	320	240	205	410	370	330	320	250	215	250	190	170
	3	320	240	205	370	330	305	280	215	185	215	170	140
	4	-	-	-	275	260	230	235	170	145	180	130	110
	5	-	-	-	330	300	275	310	235	200	240	180	150
	6	-	-	-	230	205	175	205	160	130	160	120	100
M	1	-	-	-	270	240	210	190	120	80	130	80	60
	2	-	-	-	245	210	190	120	80	50	80	50	40
	3	-	-	-	190	175	150	125	80	55	85	50	40
K	1	400	300	250	420	360	300	275	245	220	220	205	180
	2	540	365	280	360	300	250	215	190	180	175	155	140
	3	310	190	155	300	250	200	180	160	145	155	145	125
N	1	-	-	-	-	-	-	-	-	-	-	-	-
	2	-	-	-	-	-	-	-	-	-	-	-	-
	3	-	-	-	-	-	-	-	-	-	-	-	-
S	1	-	-	-	-	-	-	-	-	-	50	35	30
	2	-	-	-	-	-	-	-	-	-	25	20	10
	3	-	-	-	-	-	-	-	-	-	70	40	30
	4	-	-	-	-	-	-	-	-	-	60	30	25
H	1	175	140	95	145	110	70	-	-	-	-	-	-
	2	175	140	95	145	110	70	-	-	-	-	-	-
	3	140	115	80	115	80	45	-	-	-	-	-	-

Copy Mills

Material Group		TN7525			TN7535			TTI25		
P	1	410	310	280	545	475	445	430	360	300
	2	310	250	215	335	305	275	310	250	215
	3	280	215	185	305	275	245	310	250	215
	4	235	170	145	230	210	190	265	215	180
	5	310	235	200	310	275	250	320	235	200
	6	205	160	130	190	160	130	145	110	90
M	1	245	220	185	245	220	185	480	310	215
	2	220	190	170	220	190	170	325	205	145
	3	175	155	140	175	155	140	320	210	145
K	1	380	280	240	355	320	290	220	185	155
	2	325	240	200	280	250	230	180	145	125
	3	240	200	170	235	210	190	145	125	100
N	1	-	-	-	-	-	-	-	-	-
	2	-	-	-	-	-	-	-	-	-
	3	-	-	-	-	-	-	-	-	-
S	1	-	-	-	-	-	-	-	-	-
	2	-	-	-	-	-	-	-	-	-
	3	-	-	-	-	-	-	-	-	-
	4	-	-	-	-	-	-	-	-	-
H	1	-	-	-	-	-	-	-	-	-
	2	-	-	-	-	-	-	-	-	-
	3	-	-	-	-	-	-	-	-	-

NOTE: FIRST choice starting speeds are in **bold** type.
As the average chip thickness increases, the speed should be decreased.

■ Recommended Starting Feeds [mm] • .B..10

Light Machining	General Purpose	Heavy Machining
-----------------	-----------------	-----------------

At 4,76 Axial Depth of Cut (ap)

Insert Geometry	Programmed Feed per Tooth (fz) as a % of Radial Depth of Cut (ae)															Insert Geometry
	5%			10%			20%			30%			40-100%			
BF	0,12	0,23	0,42	0,08	0,16	0,29	0,06	0,12	0,21	0,05	0,10	0,18	0,05	0,10	0,17	BF
BR	0,19	0,29	0,51	0,14	0,20	0,35	0,10	0,15	0,25	0,09	0,13	0,22	0,08	0,12	0,20	BR

At 2,38 Axial Depth of Cut (ap)

Insert Geometry	Programmed Feed per Tooth (fz) as a % of Radial Depth of Cut (ae)															Insert Geometry
	5%			10%			20%			30%			40-100%			
BF	0,14	0,27	0,49	0,10	0,19	0,34	0,07	0,14	0,25	0,06	0,12	0,21	0,06	0,11	0,19	BF
BR	0,22	0,34	0,61	0,16	0,24	0,40	0,12	0,17	0,29	0,10	0,15	0,25	0,09	0,14	0,23	BR

At 1,19 Axial Depth of Cut (ap)

Insert Geometry	Programmed Feed per Tooth (fz) as a % of Radial Depth of Cut (ae)															Insert Geometry
	5%			10%			20%			30%			40-100%			
BF	0,18	0,36	0,68	0,13	0,25	0,45	0,09	0,18	0,32	0,08	0,16	0,28	0,08	0,15	0,25	BF
BR	0,29	0,46	0,84	0,21	0,31	0,54	0,15	0,23	0,39	0,13	0,20	0,33	0,12	0,18	0,30	BR

At 0,60 Axial Depth of Cut (ap)

Insert Geometry	Programmed Feed per Tooth (fz) as a % of Radial Depth of Cut (ae)															Insert Geometry
	5%			10%			20%			30%			40-100%			
BF	0,25	0,51	1,02	0,18	0,34	0,63	0,13	0,25	0,44	0,11	0,22	0,38	0,10	0,20	0,35	BF
BR	0,41	0,66	1,34	0,28	0,44	0,76	0,21	0,31	0,53	0,18	0,27	0,45	0,17	0,25	0,41	BR

NOTE: Use "Light Machining" value as starting feed rate.

■ Recommended Starting Feeds [mm] • .B..12

Light Machining	General Purpose	Heavy Machining
-----------------	-----------------	-----------------

At 5,00 Axial Depth of Cut (ap)

Insert Geometry	Programmed Feed per Tooth (fz) as a % of Radial Depth of Cut (ae)															Insert Geometry
	5%			10%			20%			30%			40-100%			
BR	0,13	0,29	0,43	0,09	0,20	0,30	0,07	0,15	0,22	0,06	0,13	0,19	0,06	0,12	0,18	BR
BF	0,21	0,39	0,58	0,15	0,27	0,40	0,11	0,20	0,29	0,10	0,18	0,25	0,09	0,16	0,23	BF

At 2,50 Axial Depth of Cut (ap)

Insert Geometry	Programmed Feed per Tooth (fz) as a % of Radial Depth of Cut (ae)															Insert Geometry
	5%			10%			20%			30%			40-100%			
BR	0,15	0,33	0,50	0,11	0,24	0,35	0,08	0,17	0,26	0,07	0,15	0,22	0,06	0,14	0,20	BR
BF	0,24	0,46	0,69	0,17	0,32	0,47	0,13	0,23	0,34	0,11	0,20	0,29	0,10	0,18	0,27	BF

At 1,25 Axial Depth of Cut (ap)

Insert Geometry	Programmed Feed per Tooth (fz) as a % of Radial Depth of Cut (ae)															Insert Geometry
	5%			10%			20%			30%			40-100%			
BR	0,20	0,45	0,68	0,14	0,31	0,46	0,11	0,23	0,34	0,09	0,20	0,29	0,08	0,18	0,27	BR
BF	0,32	0,61	0,94	0,23	0,42	0,62	0,17	0,31	0,45	0,15	0,26	0,38	0,13	0,24	0,35	BF

At 0,63 Axial Depth of Cut (ap)

Insert Geometry	Programmed Feed per Tooth (fz) as a % of Radial Depth of Cut (ae)															Insert Geometry
	5%			10%			20%			30%			40-100%			
BR	0,28	0,63	0,99	0,20	0,43	0,64	0,15	0,31	0,46	0,13	0,27	0,40	0,12	0,25	0,36	BR
BF	0,45	0,89	1,42	0,31	0,58	0,87	0,23	0,42	0,61	0,20	0,36	0,53	0,18	0,33	0,48	BF

NOTE: Use "Light Machining" value as starting feed rate.

Copy Mills

■ Recommended Starting Feeds [mm] • .B..16

Light Machining	General Purpose	Heavy Machining
-----------------	-----------------	-----------------

At 8,00 Axial Depth of Cut (ap)

Insert Geometry	Programmed Feed per Tooth (fz) as a % of Radial Depth of Cut (ae)															Insert Geometry
	5%			10%			20%			30%			40-100%			
BF	0,14	0,28	0,45	0,10	0,20	0,31	0,08	0,15	0,23	0,07	0,13	0,20	0,06	0,12	0,18	BF
BR	0,21	0,38	0,59	0,15	0,27	0,41	0,11	0,20	0,30	0,10	0,17	0,26	0,09	0,16	0,24	BR

At 4,00 Axial Depth of Cut (ap)

Insert Geometry	Programmed Feed per Tooth (fz) as a % of Radial Depth of Cut (ae)															Insert Geometry
	5%			10%			20%			30%			40-100%			
BF	0,16	0,33	0,52	0,12	0,23	0,36	0,09	0,17	0,27	0,08	0,15	0,23	0,07	0,14	0,21	BF
BR	0,24	0,45	0,69	0,17	0,31	0,48	0,13	0,23	0,35	0,11	0,20	0,30	0,10	0,18	0,28	BR

At 2,00 Axial Depth of Cut (ap)

Insert Geometry	Programmed Feed per Tooth (fz) as a % of Radial Depth of Cut (ae)															Insert Geometry
	5%			10%			20%			30%			40-100%			
BF	0,21	0,44	0,70	0,15	0,31	0,48	0,11	0,23	0,35	0,10	0,20	0,30	0,09	0,18	0,28	BF
BR	0,32	0,60	0,94	0,23	0,42	0,63	0,17	0,31	0,46	0,15	0,26	0,40	0,13	0,24	0,36	BR

At 1,00 Axial Depth of Cut (ap)

Insert Geometry	Programmed Feed per Tooth (fz) as a % of Radial Depth of Cut (ae)															Insert Geometry
	5%			10%			20%			30%			40-100%			
BF	0,29	0,61	0,99	0,21	0,43	0,66	0,16	0,31	0,48	0,14	0,27	0,42	0,12	0,25	0,38	BF
BR	0,44	0,85	1,38	0,31	0,57	0,88	0,23	0,42	0,63	0,20	0,36	0,54	0,18	0,33	0,50	BR

NOTE: Use "Light Machining" value as starting feed rate.

■ Recommended Starting Feeds [mm] • .B..20

Light Machining	General Purpose	Heavy Machining
-----------------	-----------------	-----------------

At 10,00 Axial Depth of Cut (ap)

Insert Geometry	Programmed Feed per Tooth (fz) as a % of Radial Depth of Cut (ae)															Insert Geometry
	5%			10%			20%			30%			40-100%			
BF	0,19	0,24	0,40	0,13	0,17	0,28	0,10	0,13	0,21	0,09	0,11	0,18	0,08	0,10	0,17	BF
BR	0,24	0,38	0,65	0,17	0,27	0,46	0,13	0,20	0,34	0,11	0,17	0,30	0,10	0,16	0,27	BR

At 5,00 Axial Depth of Cut (ap)

Insert Geometry	Programmed Feed per Tooth (fz) as a % of Radial Depth of Cut (ae)															Insert Geometry
	5%			10%			20%			30%			40-100%			
BF	0,22	0,28	0,46	0,15	0,20	0,33	0,12	0,15	0,24	0,10	0,13	0,21	0,09	0,12	0,19	BF
BR	0,27	0,44	0,76	0,20	0,31	0,53	0,15	0,23	0,39	0,13	0,20	0,34	0,12	0,18	0,31	BR

At 2,50 Axial Depth of Cut (ap)

Insert Geometry	Programmed Feed per Tooth (fz) as a % of Radial Depth of Cut (ae)															Insert Geometry
	5%			10%			20%			30%			40-100%			
BF	0,28	0,37	0,61	0,20	0,27	0,43	0,15	0,20	0,32	0,13	0,17	0,28	0,12	0,16	0,25	BF
BR	0,36	0,58	1,01	0,26	0,41	0,70	0,19	0,30	0,52	0,17	0,26	0,45	0,15	0,24	0,41	BR

At 1,25 Axial Depth of Cut (ap)

Insert Geometry	Programmed Feed per Tooth (fz) as a % of Radial Depth of Cut (ae)															Insert Geometry
	5%			10%			20%			30%			40-100%			
BF	0,39	0,51	0,85	0,28	0,36	0,59	0,21	0,27	0,44	0,18	0,23	0,38	0,17	0,21	0,35	BF
BR	0,50	0,81	1,44	0,36	0,56	0,97	0,26	0,42	0,71	0,23	0,36	0,61	0,21	0,33	0,56	BR

NOTE: Use "Light Machining" value as starting feed rate.

Copy Mills

■ Recommended Starting Feeds [mm] • .B..25

Light Machining	General Purpose	Heavy Machining
-----------------	-----------------	-----------------

At 12,50 Axial Depth of Cut (ap)

Insert Geometry	Programmed Feed per Tooth (fz) as a % of Radial Depth of Cut (ae)															Insert Geometry
	5%			10%			20%			30%			40-100%			
BF	0,17	0,31	0,50	0,13	0,22	0,36	0,09	0,16	0,26	0,08	0,14	0,23	0,08	0,13	0,21	BF
BR	0,24	0,38	0,65	0,17	0,27	0,46	0,13	0,20	0,34	0,11	0,17	0,30	0,10	0,16	0,27	BR

At 6,25 Axial Depth of Cut (ap)

Insert Geometry	Programmed Feed per Tooth (fz) as a % of Radial Depth of Cut (ae)															Insert Geometry
	5%			10%			20%			30%			40-100%			
BF	0,20	0,35	0,58	0,15	0,25	0,41	0,11	0,19	0,30	0,09	0,16	0,27	0,09	0,15	0,24	BF
BR	0,27	0,44	0,76	0,20	0,31	0,53	0,15	0,23	0,39	0,13	0,20	0,34	0,12	0,18	0,31	BR

At 3,13 Axial Depth of Cut (ap)

Insert Geometry	Programmed Feed per Tooth (fz) as a % of Radial Depth of Cut (ae)															Insert Geometry
	5%			10%			20%			30%			40-100%			
BF	0,27	0,47	0,77	0,19	0,33	0,54	0,14	0,25	0,40	0,12	0,21	0,35	0,11	0,20	0,32	BF
BR	0,36	0,58	1,02	0,26	0,41	0,70	0,19	0,30	0,52	0,17	0,26	0,45	0,15	0,24	0,41	BR

At 1,56 Axial Depth of Cut (ap)

Insert Geometry	Programmed Feed per Tooth (fz) as a % of Radial Depth of Cut (ae)															Insert Geometry
	5%			10%			20%			30%			40-100%			
BF	0,37	0,65	1,09	0,26	0,46	0,75	0,19	0,34	0,55	0,17	0,29	0,47	0,15	0,27	0,43	BF
BR	0,50	0,81	1,44	0,36	0,56	0,97	0,26	0,42	0,71	0,23	0,36	0,61	0,21	0,33	0,56	BR

NOTE: Use "Light Machining" value as starting feed rate.

Copy Mills

■ Recommended Starting Feeds [mm] • .B..32

Light Machining	General Purpose	Heavy Machining
-----------------	-----------------	-----------------

At 16,00 Axial Depth of Cut (ap)

Insert Geometry	Programmed Feed per Tooth (fz) as a % of Radial Depth of Cut (ae)															Insert Geometry
	5%			10%			20%			30%			40-100%			
BF	0,17	0,30	0,47	0,13	0,22	0,34	0,09	0,16	0,25	0,08	0,14	0,22	0,08	0,13	0,20	BF
BR	0,23	0,38	0,59	0,17	0,27	0,42	0,13	0,20	0,31	0,11	0,17	0,27	0,10	0,16	0,25	BR

At 8,00 Axial Depth of Cut (ap)

Insert Geometry	Programmed Feed per Tooth (fz) as a % of Radial Depth of Cut (ae)															Insert Geometry
	5%			10%			20%			30%			40-100%			
BF	0,20	0,35	0,55	0,15	0,25	0,39	0,11	0,19	0,29	0,09	0,16	0,25	0,09	0,15	0,23	BF
BR	0,27	0,43	0,69	0,19	0,31	0,49	0,14	0,23	0,36	0,13	0,20	0,32	0,12	0,18	0,29	BR

At 4,00 Axial Depth of Cut (ap)

Insert Geometry	Programmed Feed per Tooth (fz) as a % of Radial Depth of Cut (ae)															Insert Geometry
	5%			10%			20%			30%			40-100%			
BF	0,26	0,46	0,72	0,19	0,33	0,51	0,14	0,25	0,38	0,12	0,21	0,33	0,11	0,20	0,30	BF
BR	0,35	0,57	0,92	0,25	0,41	0,64	0,19	0,30	0,48	0,17	0,26	0,41	0,15	0,24	0,38	BR

At 2,00 Axial Depth of Cut (ap)



Insert Geometry	Programmed Feed per Tooth (fz) as a % of Radial Depth of Cut (ae)															Insert Geometry
	5%			10%			20%			30%			40-100%			
BF	0,36	0,64	1,01	0,26	0,45	0,71	0,19	0,34	0,52	0,17	0,29	0,45	0,15	0,27	0,41	BF
BR	0,49	0,80	1,28	0,35	0,56	0,89	0,26	0,42	0,65	0,23	0,36	0,57	0,21	0,33	0,52	BR

NOTE: Use "Light Machining" value as starting feed rate.

Copy Mills

Selecting the Correct Insert and Cutting Conditions for Your Application

1. Insert Style: Considerations for Selecting the Correct Insert

Best Choices for Insert and Grade Selection ● First choice ○ Alternate choice	BR Geometry		BF Geometry
			
Grade	TN7535	TN2510	TN2505
Roughing Operation	●	○	
Finishing Operation		○	●
Low RPM Machine	●	○	
Flat Areas or Face Milling (≤10° inclination)	●	○	
Hard Machining		○	●
Unstable and/or Long Overhangs	●	○	
HSM or 5-Axis Machining (smaller ap/ae values)	●	○	

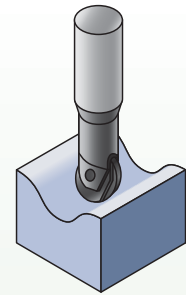

2. Calculating effective diameter and resulting surface speed

It is important to consider the effective diameter (Deff) when using light depths of cut in order to properly calculate RPM values. Use the following formula when machining flat surfaces or inclinations of 10° or less to find the Deff value, and then use this for RPM calculations as opposed to using the overall insert diameter (D1).

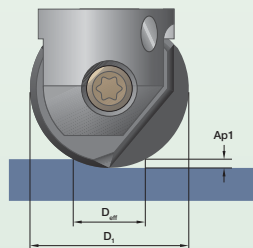

When machining inclinations between 11° and 55°, further modification of vc is required. Apply factor "k" from the given formula to calculate the correct vc (vceff). This corrected value is then used to calculate the proper RPM for the tool.

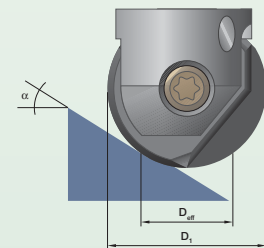

$$Deff = \sqrt{D1^2 - (D1 - 2Ap1)^2}$$

$$k = \frac{1}{\sin [\alpha + \arccos (1 - (2 (Ap1/D1)))]}$$

$$v_{c\text{eff}} = v_c \times k$$

Starting Values for Semi-Finishing in Common Material Types (L/D ratio <3 x D1)

M270 is usually applied for semi-finishing and finishing operations; Ap1/ae conditions depend on the operation. As a general rule: Ap1/ae ≤ 0,05D.

Material	Tool Diameter																	
	Ø10		Ø12		Ø16		Ø20		Ø25		Ø32							
	max rec. (mm)		fz (mm/tooth)		max rec. (mm)		fz (mm/tooth)		max rec. (mm)		fz (mm/tooth)		max rec. (mm)		fz (mm/tooth)			
	Ap1	ae	Ap1	ae	Ap1	ae	Ap1	ae	Ap1	ae	Ap1	ae	Ap1	ae	Ap1	ae		
Soft Steel <250 HB	0,7	0,7	0,2	0,8	0,8	0,2	1,1	1,1	0,27	1,3	1,3	0,27	1,7	1,7	0,3	2,1	2,1	0,3
High-Strength Steel 33-44 HRC	0,5	0,5	0,15	0,6	0,6	0,2	0,8	0,8	0,25	1	1	0,25	1,3	1,3	0,25	1,6	1,6	0,25
Hardened Steel 44-55 HRC	0,3	0,3	0,15	0,4	0,4	0,2	0,5	0,5	0,22	0,7	0,7	0,22	0,8	0,8	0,25	1,1	1,1	0,25
Grey Cast Iron GG25...	1	1	0,2	1,2	1,2	0,25	1,6	1,6	0,25	2	2	0,25	2,5	2,5	0,3	3,2	3,2	0,3
Nodular Cast Iron GGG60...	0,7	0,7	0,2	0,8	0,8	0,25	1,1	1,1	0,25	1,3	1,3	0,25	1,7	1,7	0,3	2,1	2,1	0,3

- Semi-finishing and finishing applications.
- Through tool coolant.
- Secure and rigid insert clamping.

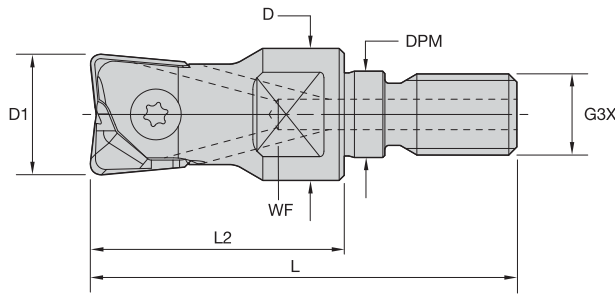
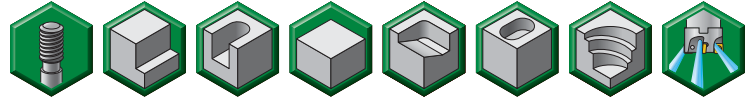

■ Toroidal • Screw-On End Mills

order number	catalogue number	D1	D	DPM	G3X	L	L2	WF	Z	Z U	inserts	max RPM	coolant supply	kg
3926546	M270TD012M08	12	13	8,5	M8	42	25	10	1	2	M270TF12R..	55000	Yes	0,02
3926547	M270TD016M08	16	13	8,5	M8	47	30	10	1	2	M270TF16R..	53000	Yes	0,09
3926548	M270TD020M10	20	18	10,5	M10	59	40	14	1	2	M270TF20R..	52000	Yes	0,07

NOTE: ZU = Effective teeth.
Z = number of pocket seats.

■ Spare Parts



D1	insert screw	Nm	Torx driver
12	12748610600	2,0	12148788900
16	12748610700	5,0	12148099300
20	12748610800	5,0	12148099300

NOTE: All spare parts except the insert screws must be ordered separately.

Copy Mills

- Semi-finishing and finishing applications.
- Through tool coolant.
- Secure and rigid insert clamping.

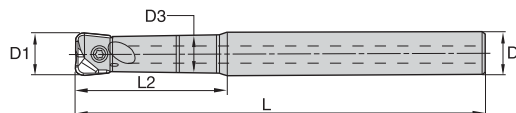
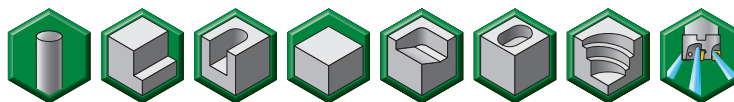

■ **Toroidal • Cylindrical Shanks**

order number	catalogue number	D1	D	D3	L	L2	Z	Z U	inserts	max RPM	coolant supply	kg
3926514	M270TD010A10L120	10	10	9	120	45	1	2	M270TF10R..	57000	Yes	0,06
3926515	M270TD012A12L140	12	12	11	140	50	1	2	M270TF12R..	55000	Yes	0,09
3926516	M270TD016A16L160	16	16	14	160	57	1	2	M270TF16R..	53000	Yes	0,19
3926517	M270TD020A20L180	20	20	18	180	70	1	2	M270TF20R..	52000	Yes	0,35

NOTE: ZU = Effective teeth.
Z = number of pocket seats.

■ **Spare Parts**



insert screw



Nm



Torx driver

D1	insert screw	Nm	Torx driver
10	12748610500	2,0	12148788900
12	12748610600	2,0	12148788900
16	12748610700	5,0	12148099300
20	12748610800	5,0	12148099300

NOTE: All spare parts except the insert screws must be ordered separately.

- Semi-finishing and finishing applications.
- Through tool coolant.
- Carbide shank for higher rigidity.

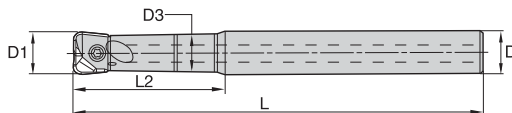
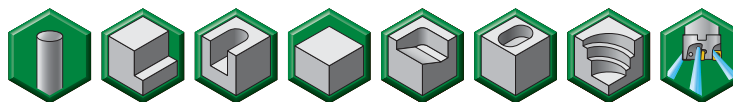

■ Toroidal • Carbide Cylindrical Shanks

order number	catalogue number	D1	D	D3	L	L2	Z	Z U	inserts	max RPM	coolant supply	kg
3926518	M270TD010A10L120C	10	10	9	120	45	1	2	M270TF10R..	57000	Yes	0,11
3926519	M270TD010A10L150C	10	10	9	150	45	1	2	M270TF10R..	57000	Yes	0,14
3926520	M270TD012A12L120C	12	12	11	120	50	1	2	M270TF12R..	55000	Yes	0,15
3926521	M270TD012A12L160C	12	12	11	160	50	1	2	M270TF12R..	55000	Yes	0,22
3926522	M270TD016A16L140C	16	16	14	140	57	1	2	M270TF16R..	53000	Yes	0,32
3926543	M270TD016A16L180C	16	16	14	180	57	1	2	M270TF16R..	53000	Yes	0,44
3926544	M270TD020A20L150C	20	20	18	150	70	1	2	M270TF20R..	52000	Yes	0,52
3926545	M270TD020A20L200C	20	20	18	200	70	1	2	M270TF20R..	52000	Yes	0,74

NOTE: ZU = Effective teeth.
Z = number of pocket seats.

■ Spare Parts



D1	insert screw	Nm	Torx driver
10	12748610500	2,0	12148788900
12	12748610600	2,0	12148788900
16	12748610700	5,0	12148099300
20	12748610800	5,0	12148099300

NOTE: All spare parts except the insert screws must be ordered separately.

■ Insert Selection Guide

Material Group	Light Machining		General Purpose		Heavy Machining	
	Geometry	Grade	Geometry	Grade	Geometry	Grade
P1-P2	TF	TN2510	TF	TN2525	TF	TN2525
P3-P4	TF	TN2510	TF	TN2525	TF	TN2525
P5-P6	TF	TN2510	TF	TN2525	-	-
M1-M2	TF	TN2510	-	-	-	-
M3	TF	TN2510	-	-	-	-
K1-K2	TF	TN2510	TF	TN2525	-	-
K3	TF	TN2510	TF	TN2525	-	-
N1-N2	-	-	-	-	-	-
N3	-	-	-	-	-	-
S1-S2	TF	TN2510	-	-	-	-
S3	TF	TN2510	-	-	-	-
S4	TF	TN2510	-	-	-	-
H1	TF	TN2505	TF	TN2510	-	-



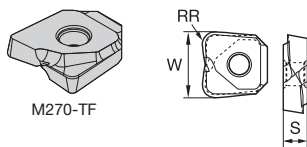

● first choice
○ alternate choice

- Precision insert for finishing and semi-finishing applications.
- Back draft design to minimise vibration and improve surface finishes.

P	●	○	○	●
M	●	○	○	○
K	●	○	○	○
N	○	○	○	○
S	○	○	○	○
H	○	○	○	○

■ M270 Toroidal

catalogue number	W	S	RR	hm	TN2505	TN2510	TN2525
M270TF10R05	10,00	2,38	0,50	0,08	○	○	○
M270TF10R1	10,00	2,38	1,00	0,08	○	○	○
M270TF12R05	12,00	3,18	0,50	0,08	○	○	○
M270TF12R1	12,00	3,18	1,01	0,08	○	○	○
M270TF12R2	12,00	3,18	2,01	0,08	○	○	○
M270TF16R03	16,00	4,76	0,30	0,08	○	○	○
M270TF16R05	16,00	4,76	0,50	0,08	○	○	○
M270TF16R1	16,00	4,76	1,01	0,08	○	○	○
M270TF16R2	16,00	4,76	2,02	0,08	○	○	○
M270TF16R3	16,00	4,76	3,04	0,08	○	○	○
M270TF20R03	20,00	4,76	0,30	0,08	○	○	○
M270TF20R05	20,00	4,76	0,50	0,08	○	○	○
M270TF20R1	20,00	4,76	1,01	0,08	○	○	○
M270TF20R2	20,00	4,76	2,01	0,08	○	○	○
M270TF20R4	20,00	4,76	4,02	0,08	○	○	○

NOTE: Ap1 max is equal to RR.

Copy Mills

■ Recommended Starting Speeds [m/min]

Material Group		TN2505			TN2510			TN2525		
P	1	550	420	360	660	580	540	550	420	360
	2	320	240	205	410	370	330	320	240	205
	3	320	240	205	370	330	305	320	240	205
	4	-	-	-	275	260	230	-	-	-
	5	-	-	-	330	300	275	-	-	-
	6	-	-	-	230	205	175	-	-	-
M	1	-	-	-	270	240	210	-	-	-
	2	-	-	-	245	210	190	-	-	-
	3	-	-	-	190	175	150	-	-	-
K	1	400	300	250	420	360	300	-	-	-
	2	540	365	280	360	300	250	-	-	-
	3	310	190	155	300	250	200	-	-	-
N	1	-	-	-	-	-	-	-	-	-
	2	-	-	-	-	-	-	-	-	-
	3	-	-	-	-	-	-	-	-	-
S	1	-	-	-	-	-	-	-	-	-
	2	-	-	-	-	-	-	-	-	-
	3	-	-	-	-	-	-	-	-	-
	4	-	-	-	-	-	-	-	-	-
H	1	175	140	95	145	110	70	130	90	60
	2	175	140	95	145	110	70	130	90	60
	3	140	115	80	115	80	45	-	-	-

NOTE: FIRST choice starting speeds are in **bold** type.
As the average chip thickness increases, the speed should be decreased.

Copy Mills

Recommended Starting Feeds

■ Recommended Starting Feeds [mm]

Light Machining	General Purpose	Heavy Machining
-----------------	-----------------	-----------------

Insert Geometry	Programmed Feed per Tooth (fz) as a % of Radial Depth of Cut (ae)															Insert Geometry
	5%			10%			20%			30%			40-100%			
TF	0,12	0,37	0,62	0,09	0,26	0,43	0,06	0,19	0,31	0,06	0,17	0,27	0,05	0,15	0,25	TF

NOTE: Use "Light Machining" value as starting feed rate.

- High metal removal rates.
- Excellent in long reach applications.
- Rough and semi-finishing applications.

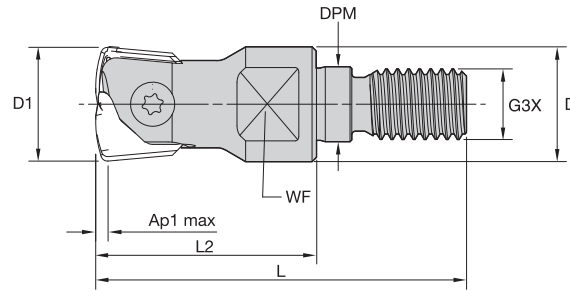
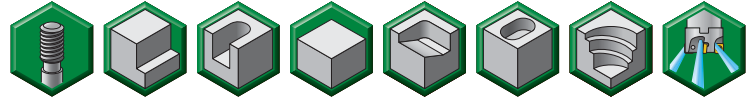

■ **High-Feed • Screw-On End Mills**

order number	catalogue number	D1	D	DPM	G3X	L	L2	WF	Ap1 max	Z	Z U	insert 1	insert 2*	max RPM	coolant supply	kg
3926546	M270TD012M08	12	13	8,5	M8	42	25	10	0,6	1	2	M270HF12	M270HF13	55000	Yes	0,02
3926547	M270TD016M08	16	13	8,5	M8	47	30	10	0,9	1	2	M270HF16	M270HF17	53000	Yes	0,09
3926548	M270TD020M10	20	18	10,5	M10	59	40	14	1,1	1	2	M270HF20	—	52000	Yes	0,07

NOTE: ZU = Effective teeth.
Z = number of pocket seats.
*D1 = 13mm when using M270HF13; D1 = 17mm when using M270HF17.

■ **Spare Parts**



insert screw



Nm



Torx driver

D1	insert screw	Nm	Torx driver
12	12748610600	2	12148788900
16	12748610700	5	12148099300
20	12748610800	5	12148099300

NOTE: All spare parts except the insert screws must be ordered separately.

- High metal removal rates.
- Excellent in long reach applications.
- Rough and semi-finishing applications.

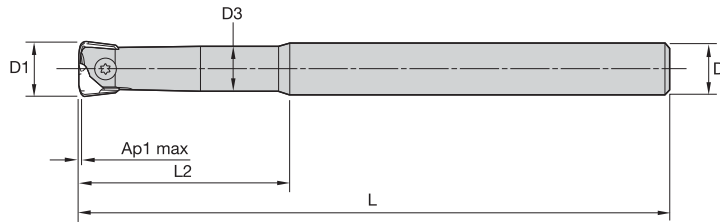
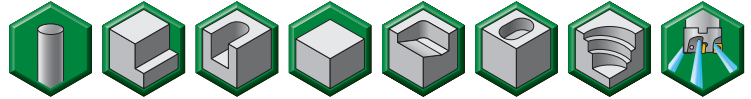

■ High-Feed • Cylindrical Shanks

order number	catalogue number	D1	D	D3	L	L2	Ap1 max	Z	Z U	insert 1	insert 2*	max RPM	coolant supply	kg
3926514	M270TD010A10L120	10	10	9	120	45	0,6	1	2	M270HF10	—	57000	Yes	0,06
3926515	M270TD012A12L140	12	12	11	140	50	0,6	1	2	M270HF12	M270HF13	55000	Yes	0,09
3926516	M270TD016A16L160	16	16	14	160	57	0,9	1	2	M270HF16	M270HF17	53000	Yes	0,19
3926517	M270TD020A20L180	20	20	18	180	70	1,1	1	2	M270HF20	—	52000	Yes	0,35

NOTE: ZU = Effective teeth.
Z = number of pocket seats.
*D1 = 13mm when using M270HF13; D1 = 17mm when using M270HF17.

■ Spare Parts



D1	insert screw	Nm	Torx driver
10	12748610500	2,0	12148788900
12	12748610600	2,0	12148788900
16	12748610700	5,0	12148099300
20	12748610800	5,0	12148099300

NOTE: All spare parts except the insert screws must be ordered separately.

- High metal removal rates.
- Excellent in long reach applications.
- Carbide shank for higher rigidity.

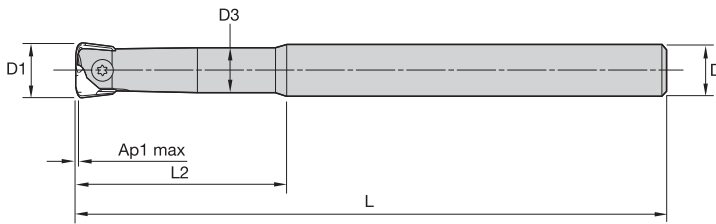
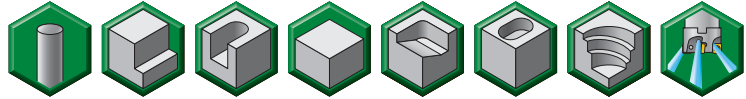

■ High-Feed • Carbide Cylindrical Shanks

order number	catalogue number	D1	D	D3	L	L2	Ap1 max	Z	Z U	insert 1	insert 2*	max RPM	coolant supply	kg
3926518	M270TD010A10L120C	10	10	9	120	45	0,6	1	2	M270HF10	—	57000	Yes	0,11
3926519	M270TD010A10L150C	10	10	9	150	45	0,6	1	2	M270HF10	—	57000	Yes	0,14
3926520	M270TD012A12L120C	12	12	11	120	50	0,6	1	2	M270HF12	M270HF13	55000	Yes	0,15
3926521	M270TD012A12L160C	12	12	11	160	50	0,6	1	2	M270HF12	M270HF13	55000	Yes	0,22
3926522	M270TD016A16L140C	16	16	14	140	57	0,9	1	2	M270HF16	M270HF17	53000	Yes	0,32
3926543	M270TD016A16L180C	16	16	14	180	57	0,9	1	2	M270HF16	M270HF17	53000	Yes	0,44
3926544	M270TD020A20L150C	20	20	18	150	70	1,1	1	2	M270HF20	—	52000	Yes	0,52
3926545	M270TD020A20L200C	20	20	18	200	70	1,1	1	2	M270HF20	—	52000	Yes	0,74

NOTE: ZU = Effective teeth.
Z = number of pocket seats.
*D1 = 13mm when using M270HF13; D1 = 17mm when using M270HF17.

■ Spare Parts



D1	insert screw	Nm	Torx driver
10	12748610500	2,0	12148788900
12	12748610600	2,0	12148788900
16	12748610700	5,0	12148099300
20	12748610800	5,0	12148099300

NOTE: All spare parts except the insert screws must be ordered separately.

■ **Insert Selection Guide**

Material Group	Light Machining		General Purpose		Heavy Machining	
	Geometry	Grade	Geometry	Grade	Geometry	Grade
P1-P2	HF	TN6525	HF	TN6540	HF	TN6540
P3-P4	HF	TN6525	HF	TN6540	HF	TN6540
P5-P6	HF	TN6525	HF	TN6540	HF	TN6540
M1-M2	HF	TN6525	HF	TN6540	HF	TN6540
M3	HF	TN6525	HF	TN6540	HF	TN6540
K1-K2	HF	TN2505	HF	TN6525	-	-
K3	HF	TN2505	HF	TN6525	-	-
N1-N2	-	-	-	-	-	-
N3	-	-	-	-	-	-
S1-S2	HF	TN6525	HF	TN6540	-	-
S3	HF	TN6525	HF	TN6540	-	-
S4	HF	TN6525	HF	TN6540	HF	TN6540
H1	HF	TN2505	HF	TN2505	HF	TN6525

High-Feed Inserts

Copy Mills

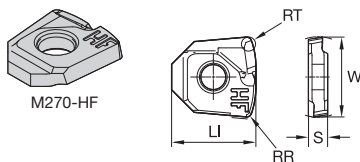

- High-Feed geometry for roughing and semi-finishing applications at maximum feed rates.
- Exceptional stability, even when long overhang is required.

- first choice
- alternate choice

P	●	○	○	○	○
M	●	○	○	○	○
K	●	○	○	○	○
N	○	○	○	○	○
S	○	○	○	○	○
H	○	○	○	○	○

■ **High-Feed**

catalogue number	W	LI	S	RR	RT	hm	TN2505	TN6525	TN6540
M270HF10	10,00	10,50	2,38	0,63	1,15	0,08	3903944	4145110	3903943
M270HF12	12,00	12,40	3,18	0,75	1,40	0,08	3903946	4145111	3903945
M270HF13	13,00	12,40	3,18	0,75	1,40	0,08	3903948	4145112	3903947
M270HF16	16,00	16,70	4,76	1,00	1,90	0,08	3903950	4145123	3903949
M270HF20	20,00	20,70	4,76	1,25	2,30	0,08	3903954	4145125	3903953

NOTE: RT = Programming radius.

■ Recommended Starting Speeds [m/min]

Material Group		TN2505			TN6525			TN6540		
P	1	550	420	360	410	320	280	360	280	240
	2	320	240	205	320	250	215	250	190	170
	3	320	240	205	280	215	185	215	170	140
	4	-	-	-	235	170	145	180	130	110
	5	-	-	-	310	235	200	240	180	150
	6	-	-	-	205	160	130	160	120	100
M	1	-	-	-	190	120	80	130	80	60
	2	-	-	-	120	80	50	80	50	40
	3	-	-	-	125	80	55	85	50	40
K	1	400	300	250	275	245	220	220	205	180
	2	540	365	280	215	190	180	175	155	140
	3	310	190	155	180	160	145	155	145	125
N	1	-	-	-	-	-	-	-	-	-
	2	-	-	-	-	-	-	-	-	-
	3	-	-	-	-	-	-	-	-	-
S	1	-	-	-	-	-	-	50	35	30
	2	-	-	-	-	-	-	25	20	10
	3	-	-	-	-	-	-	70	40	30
	4	-	-	-	-	-	-	60	30	25
H	1	175	140	95	-	-	-	-	-	-
	2	175	140	95	-	-	-	-	-	-
	3	140	115	80	-	-	-	-	-	-

NOTE: FIRST choice starting speeds are in **bold** type.
As the average chip thickness increases, the speed should be decreased.

Recommended Starting Feeds

■ Recommended Starting Feeds [mm]

Light Machining	General Purpose	Heavy Machining
-----------------	-----------------	-----------------

At 0,60 Axial Depth of Cut (ap) • HF10

Insert Geometry	Programmed Feed per Tooth (fz) as a % of Radial Depth of Cut (ae)															Insert Geometry
	5%			10%			20%			30%			40-100%			
HF	1,01	1,57	2,81	0,67	0,97	1,43	0,48	0,69	0,97	0,42	0,59	0,83	0,38	0,54	0,75	HF

At 0,60 Axial Depth of Cut (ap) • HF12

Insert Geometry	Programmed Feed per Tooth (fz) as a % of Radial Depth of Cut (ae)															Insert Geometry
	5%			10%			20%			30%			40-100%			
HF	0,91	1,53	2,81	0,61	0,96	1,43	0,45	0,69	0,99	0,39	0,59	0,85	0,35	0,54	0,77	HF

At 0,60 Axial Depth of Cut (ap) • HF13

Insert Geometry	Programmed Feed per Tooth (fz) as a % of Radial Depth of Cut (ae)															Insert Geometry
	5%			10%			20%			30%			40-100%			
HF	0,94	1,58	2,82	0,64	1,00	1,49	0,46	0,71	1,03	0,40	0,61	0,88	0,37	0,56	0,80	HF

NOTE: Use "Light Machining" value as starting feed rate.

■ Recommended Starting Feeds [mm]

Light Machining	General Purpose	Heavy Machining
-----------------	-----------------	-----------------

At 0,90 Axial Depth of Cut (ap) • HF16

Insert Geometry	Programmed Feed per Tooth (fz) as a % of Radial Depth of Cut (ae)															Insert Geometry
	5%			10%			20%			30%			40-100%			
HF	1,03	1,60	3,34	0,69	1,00	1,50	0,50	0,71	1,03	0,43	0,61	0,88	0,39	0,56	0,80	HF

At 0,90 Axial Depth of Cut (ap) • HF17

Insert Geometry	Programmed Feed per Tooth (fz) as a % of Radial Depth of Cut (ae)															Insert Geometry
	5%			10%			20%			30%			40-100%			
HF	1,06	1,63	3,00	0,71	1,03	1,52	0,51	0,73	1,05	0,44	0,63	0,90	0,40	0,57	0,82	HF

At 1,10 Axial Depth of Cut (ap) • HF20

Insert Geometry	Programmed Feed per Tooth (fz) as a % of Radial Depth of Cut (ae)															Insert Geometry
	5%			10%			20%			30%			40-100%			
HF	1,01	1,69	2,74	0,69	1,09	1,57	0,50	0,78	1,10	0,44	0,67	0,94	0,40	0,61	0,86	HF

NOTE: Use "Light Machining" value as starting feed rate.

Copy Mills

Applying High-Feed Tools

The high-feed concept bases its strategy in small depth of cut and high fz values, which results in a higher MRR and productivity with low radial forces.

Recommended when long overhang is necessary due to lower radial forces.
 Maximum L/D ratio of 10 x D.

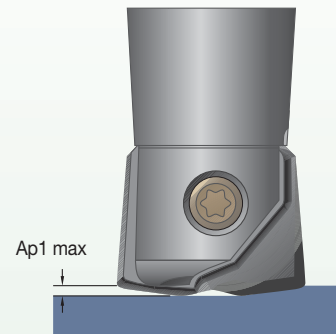
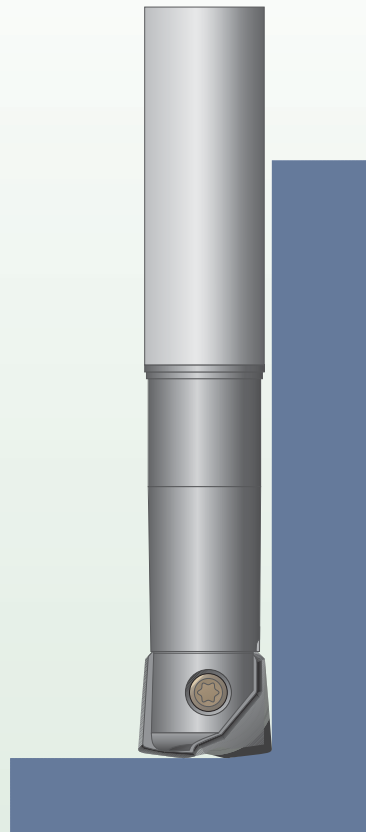

Small Ap1 values and higher feed rate generate lower cutting forces versus traditional milling strategies.

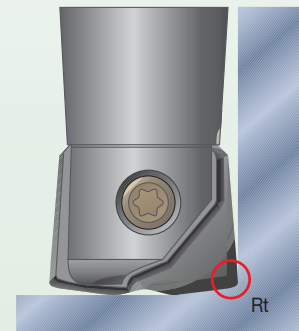

For CAM programming, the tools can be programmed as a toroidal tool type by using the Rt value as the insert radius.

L/D ratio	% of Ap1 max to reduce	% of vc to reduce
<4	0%	0%
4<L/D<7	55–65%	10–15%
>8	65–75%	20–30%

General Programming Information for Applying M270 High-Feed

tool diameter	Ø10	Ø12	Ø13	Ø16	Ø17	Ø20
recommended starting Ap1 (mm)	0,40	0,40	0,40	0,60	0,60	0,75
Rt CAM programming	1,15	1,40	1,40	1,90	1,90	2,30
fz recommended for general purpose	0,45	0,55	0,55	0,60	0,60	0,70
fz recommended for 45 HRC (approx.)	0,40	0,45	0,45	0,55	0,55	0,65
fz recommended for 55 HRC (approx.)	0,30	0,35	0,35	0,45	0,45	0,50

NOTE: Use two effective teeth for feed calculations.

For materials above 45 HRC, we recommend adjusting the ae max to 55% of cutting diameter and using no more than 50% of Ap1 max. While centre cutting is possible, we recommend using a ramp angle of 0.5°–1.0° to ensure smooth operation.

ToolBOSS™

ToolBOSS Vending Solutions

ToolBOSS vending solutions help to reduce costs and improve efficiencies to give you a competitive edge.

- Cut tooling inventory by 50% or more.
- Decrease spending on tooling by up to 30%.
- Reduce administrative costs by as much as 90%.

Customer Offering

Shared Rewards

Free use of ToolBOSS vending machine combined with a comprehensive maintenance and service package based on agreed sales targets for specified contract terms.

Direct Purchase of Equipment

ToolBOSS vending machines are available for purchase. Maintenance and service packages available with annual agreements.

For more information, please contact us at:
toolboss.com



You can also use our NOVO app to guide you to the correct choice!

For more information, please visit widia.com/novo.

NOVO: The Digital Source for Delivering Smart Machining Solutions

For more information, contact your local WIDIA Authorised Distributor or visit widia.com/services.

